

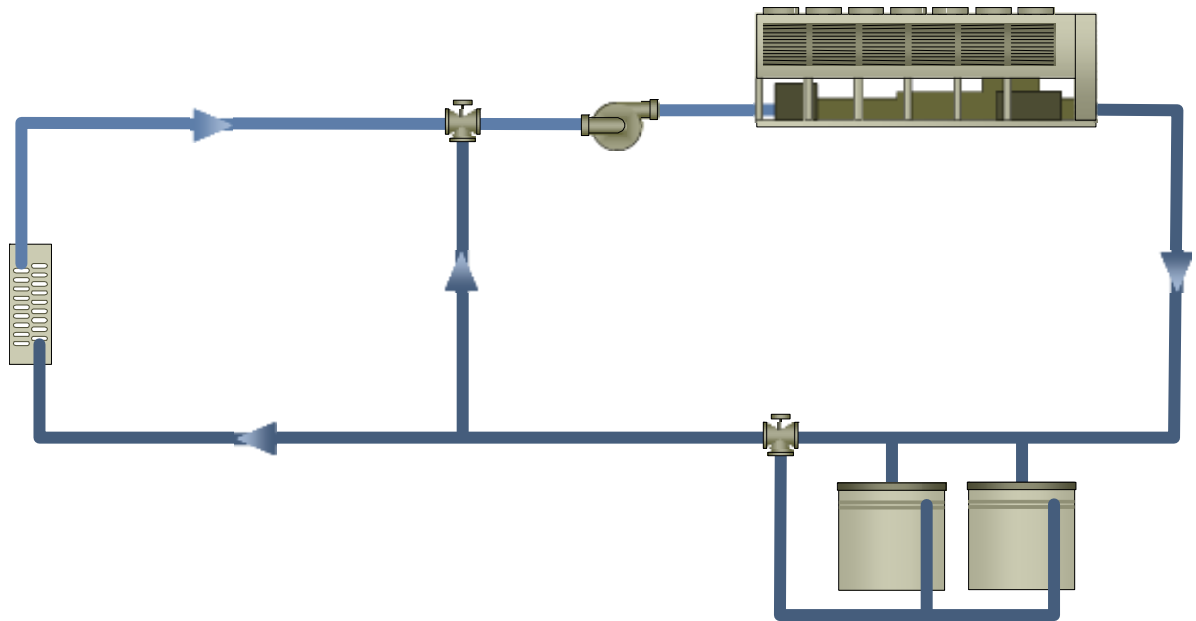

# Air Conditioning Clinic

## Ice Storage Systems One of the Systems Series







---

# Ice Storage Systems

One of the Systems Series

A publication of Trane

---

## Preface

---

### Ice Storage Systems

A Trane Air Conditioning Clinic

Figure 1

Trane believes that it is incumbent on manufacturers to serve the industry by regularly disseminating information gathered through laboratory research, testing programs, and field experience.

The Trane Air Conditioning Clinic series is one means of knowledge sharing. It is intended to acquaint a technical audience with various fundamental aspects of heating, ventilating, and air conditioning (HVAC). We have taken special care to make the clinic as uncommercial and straightforward as possible. Illustrations of Trane products only appear in cases where they help convey the message contained in the accompanying text.

This particular clinic introduces the reader to **ice storage systems**.

# Contents

---

period one	<b>Benefits of Ice Storage</b> .....	1
period two	<b>System Components</b> .....	9
	Ice Storage Tank .....	9
	Ice-Making Chiller .....	13
	Heat-Transfer Fluid .....	17
period three	<b>Design Process</b> .....	24
	Define the Mission .....	25
	Determine Ice Storage Capacity .....	26
	Select Storage Tanks and Chillers .....	33
period four	<b>System Layout</b> .....	47
period five	<b>System Control</b> .....	57
	Tactical Control .....	58
	Strategic Control .....	74
period six	<b>Review</b> .....	88
	<b>Quiz</b> .....	94
	<b>Answers</b> .....	96
	<b>Glossary</b> .....	97



period one  
**Benefits of Ice Storage**

---

notes

**Ice Storage Systems**

---

*period one*

**Benefits of Ice Storage**

Figure 2

Thermal energy storage (TES) involves adding heat (thermal) energy to a storage medium, and then removing it from that medium for use at some other time. This may involve storing thermal energy at high temperatures (heat storage) or at low temperatures (cool storage).

In HVAC applications, the most-common storage media used for cool thermal storage are ice and water. A chilled-water storage system uses the sensible-heat capacity of a large volume of water to store thermal energy. A chiller is used to lower the temperature of water, and this cool water is stored in a large tank for use at another time. An ice storage system, however, uses the latent capacity of water, associated with changing phase from a solid (ice) to a liquid (water), to store thermal energy.

This clinic focuses on cool thermal-storage systems that use ice as the storage medium, commonly called ice storage systems.

period one  
**Benefits of Ice Storage**

notes

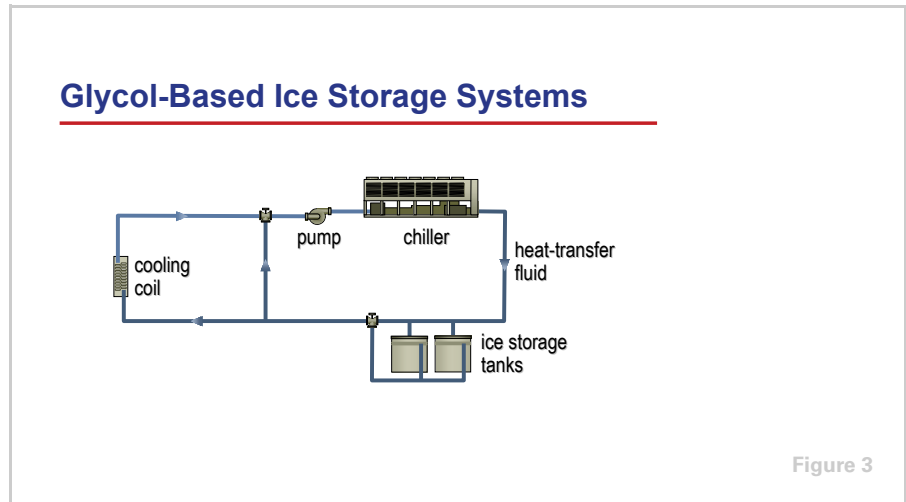

Several ice storage technologies have been introduced, flourished for a short period of time, and subsequently left the marketplace. Glycol-based ice storage systems continue to be very popular because they are simple and are similar to conventional chilled-water systems. Any application that is suitable for a chilled-water system is a candidate for glycol-based ice storage.

This type of ice storage system uses a chiller to cool a heat-transfer fluid, often a mixture of water and antifreeze (such as glycol), to a temperature below the freezing point of water. This fluid is pumped through one or more ice storage tanks, where heat is transferred from the water inside the tank to the heat-transfer fluid. This causes the water inside the tank to freeze.

When the thermal energy is needed at a later time, the heat-transfer fluid is again pumped through the storage tank, but now at a temperature above the freezing point of water. Heat is transferred from the heat-transfer fluid to the ice stored inside the tank, causing the ice to melt.



# period one

## Benefits of Ice Storage

### notes

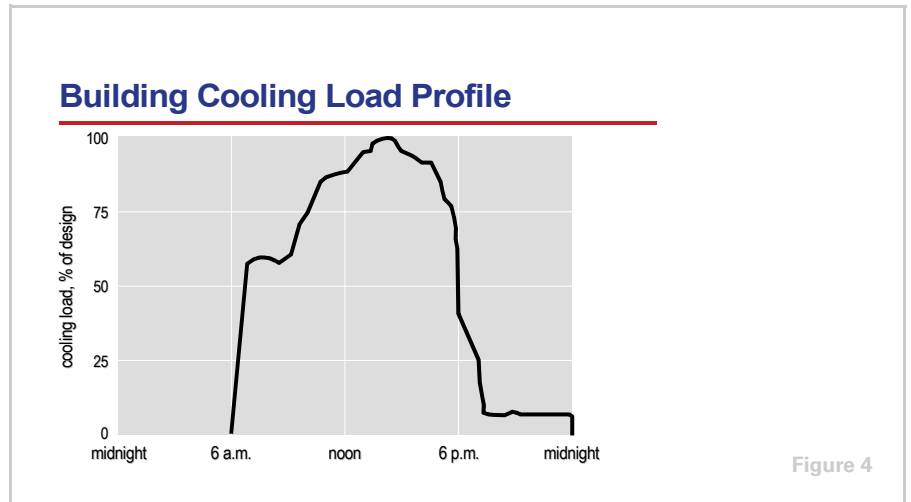

Adding ice storage to an HVAC system can reduce the utility costs associated with cooling by shifting the operation of the chiller from times of high-cost electricity to times of low-cost electricity.

Figure 4 shows a design-day cooling load profile for an example building. Between midnight and 6 a.m., the building is unoccupied and there is no cooling load. At 6 a.m., the building begins to be occupied, and the cooling load increases. The cooling load is highest between 11 a.m. and 4 p.m., and then decreases dramatically after 5 p.m. as people leave the building. There is a small cooling load that continues throughout the evening hours, before going away at midnight.

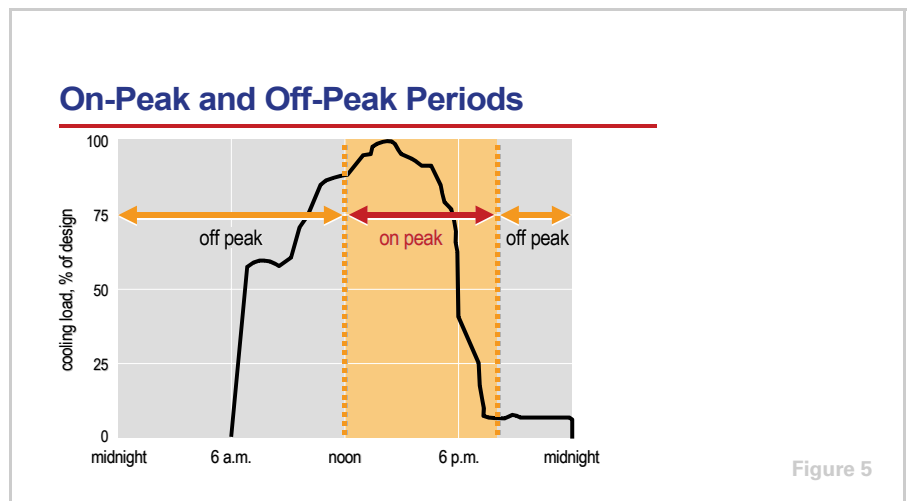

Most electric utility companies experience the greatest demand for electricity during the daytime hours, with some even facing capacity shortages. To encourage the reduction of electricity use during these times, many electric

## period one

# Benefits of Ice Storage

### notes

utility companies have established time-of-day rates that create time windows for higher-cost electricity during these periods of high demand. The hours when the cost of electricity is high are often referred to as the “on-peak” period. On the other hand, the “off-peak” period refers to the hours when the cost of electricity is lower.

For this same example building, noon to 8 p.m. is defined as the on-peak period. All other hours are defined as the off-peak period.

Another common component of the electric utility rate is a demand charge. This is a fee based on the highest power (kW) draw, or demand, used by the building during a specified time frame. Typically, either the demand charge only applies to the on-peak period, or the on-peak demand charge is significantly higher than the off-peak demand charge.

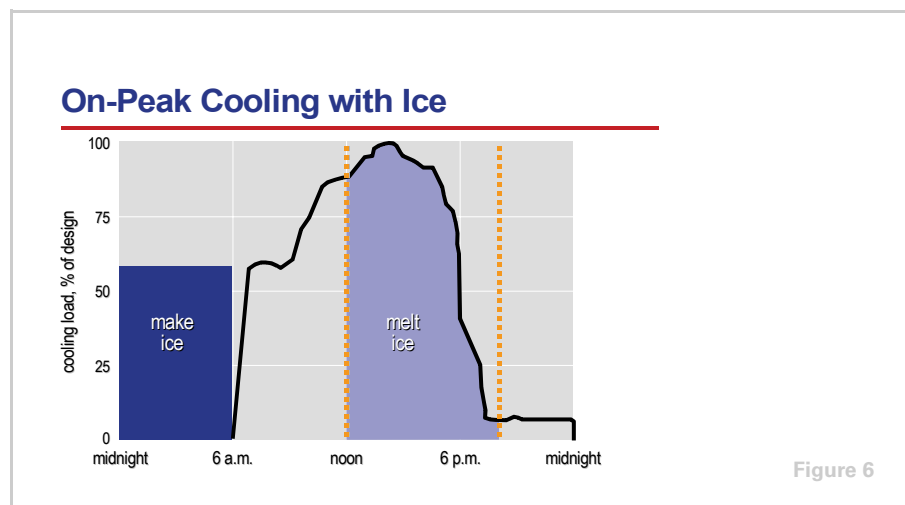

Ice storage systems lower monthly utility costs by melting ice to satisfy building cooling loads during the on-peak period. This avoids, or significantly reduces, the electricity required to operate the chiller during that time frame. The operation of the chiller is shifted to the off-peak period, during which the cost of electricity is lower and the demand charge is lower or non-existent. The chiller is used during that period to freeze the water inside the storage tanks, storing the thermal energy until the on-peak period.

In this example, the building cooling loads that occur during the on-peak period, which occurs between noon and 8 p.m., are satisfied by melting the stored ice, and the chiller is turned off.

This type of system, often called a “full-storage system,” is only possible if the storage capacity of the tanks is large enough to satisfy the on-peak cooling loads for the given day.

# period one

## Benefits of Ice Storage

### notes

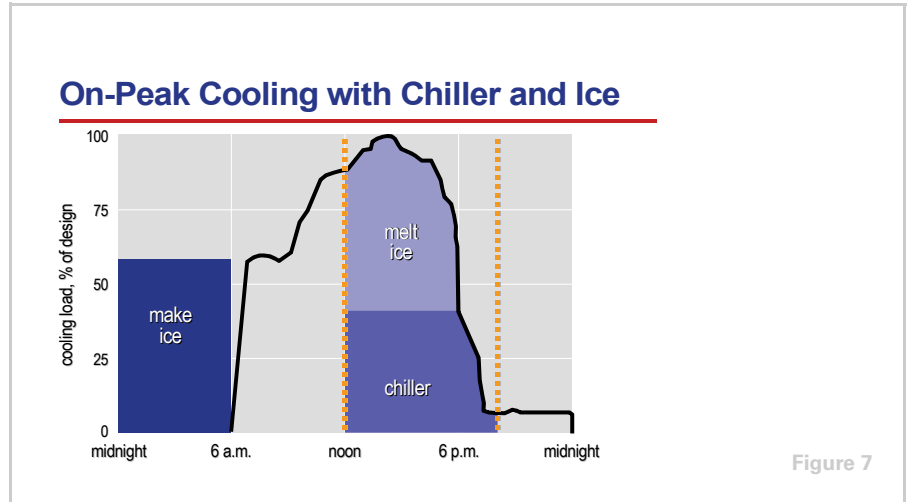

The installed cost of a full-storage system, however, may not be feasible. Many ice storage systems have enough capacity to satisfy only a portion of the on-peak cooling loads. This type of system is often called a “partial-storage system.”

In this example partial-storage system, the cooling loads that occur during the on-peak period are satisfied by melting ice and operating the chiller. The chiller operates at a reduced capacity, consumes less energy, and draws less power. Cooling loads greater than the capacity provided by the chiller are satisfied by melting the stored ice.

Turning off the chiller, or significantly reducing its capacity, during the on-peak period reduces the consumption of this higher-priced electricity and reduces the on-peak electrical demand. Both can result in lower monthly utility bills.

## period one

# Benefits of Ice Storage

## notes

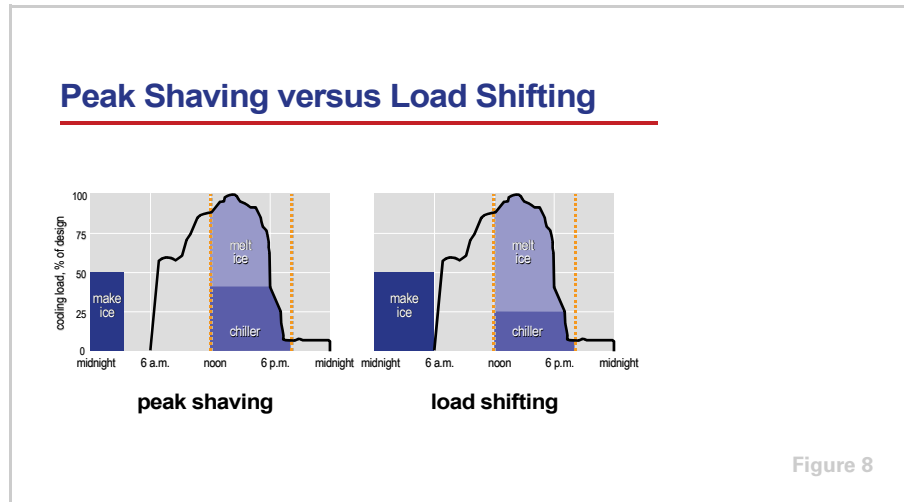

At first glance, it might appear that an ice storage system designed to reduce on-peak electrical demand (kW) is the same as a system designed to reduce on-peak electrical consumption (kWh). Which of the two is most important, however, can significantly change how the system is designed and/or controlled.

To reduce the on-peak demand, the system should melt ice only when the electrical demand of the building is highest. It is perfectly acceptable to have ice remaining inside the tank at the end of the day. This approach, called “peak shaving,” is commonly used when the on-peak electrical demand (kW) rate is high, but the electrical consumption (kWh) rates are nearly equal from off-peak to on-peak periods. Peak shaving attempts to find the optimum balance between reducing on-peak electrical demand (by melting ice and operating the chiller at reduced capacity) and avoiding significantly increasing off-peak electrical consumption (which happens when the chiller needs to operate in the ice-making mode).

Alternatively, to reduce on-peak electrical consumption, the system should melt as much ice as possible every day. This approach, called “load shifting,” is commonly used when the on-peak electrical consumption (kWh) rate is significantly higher than the off-peak consumption rate. Load shifting attempts to reduce on-peak electrical consumption as much as possible by melting all of the ice during the on-peak period, and shifting chiller operation to the off-peak period.

While it is possible that a system designed for peak shaving may have the same ice storage capacity as a system designed for load shifting, these two systems are controlled differently.

# period one

## Benefits of Ice Storage

### notes

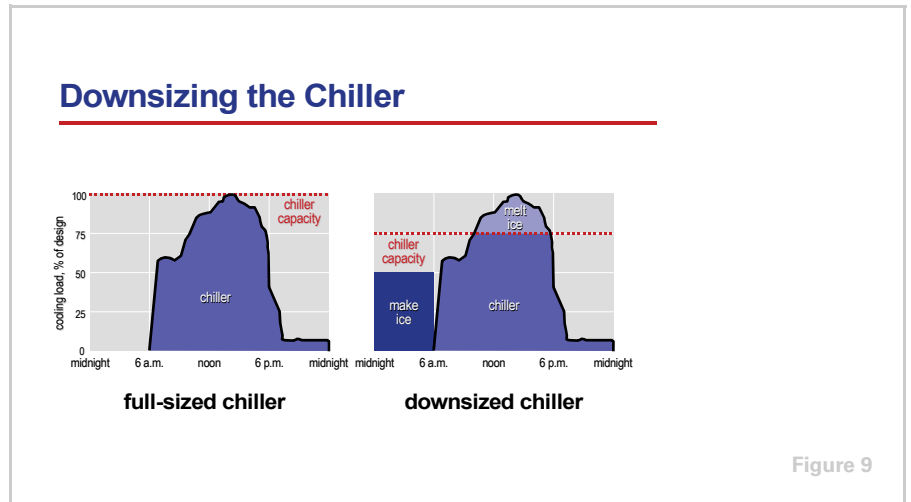

In addition to lowering monthly utility costs, another potential benefit of ice storage is to reduce the size and capacity of mechanical cooling equipment.

When ice storage is used to satisfy all or part of the design (or worst-case) cooling load, the chiller may be able to be downsized as long as the downsized chiller has sufficient time to re-freeze the water inside the tanks.

Smaller, electrically driven chillers may also result in smaller electrical service to the building, which can also reduce installed cost.

### ice storage systems

## Potential Benefits

- ▲ **Lower utility costs**
  - ◆ Lower on-peak electrical consumption (kWh)
  - ◆ Lower on-peak electrical demand (kW)
- ▲ **Smaller equipment size**
  - ◆ Smaller chiller
  - ◆ Smaller electrical service (A)
- ▲ **Reduced installed cost**
  - ◆ May qualify for utility rebates or other incentives

Figure 10

While the ice storage tanks add to the installed cost of the system, the impact of downsizing the mechanical cooling equipment may offset some (or all) of this added cost. Additionally, some electric utility companies offer rebates or other incentives when ice storage is used to reduce on-peak electrical demand. When



period one

## Benefits of Ice Storage

---

### notes

these incentives are available, adding ice storage may even reduce the overall installed cost of the system.

In some installations, each of these benefits might be realized. In other installations, however, one or more may not occur. For example, adding ice storage may lower utility costs, but the time available to re-freeze the water inside the tanks may be so short that the chiller must remain the same size in order to freeze the water fast enough.

## period two

# System Components

### notes

### Ice Storage Systems

*period two*

**System Components**

Figure 11

There are three components of a glycol-based ice storage system that differ from a conventional chilled-water system: the ice storage tank, the ice-making chiller, and a heat-transfer fluid that remains in the liquid phase at temperatures below the freezing point of water.

### Ice Storage Tank



Figure 12

#### **Ice Storage Tank**

The type of storage tank most-commonly used in a glycol-based ice storage system is called a static tank. One example of a static ice storage tank is shown in Figure 12.

A static tank is a closed vessel in which the ice serves only as a medium to store thermal energy. The tank contains a heat exchanger that is used to freeze water during one part of the day, and then melt the ice during another part of the day. This heat exchanger is typically constructed of steel, polyethylene, or polypropylene tubes that are connected to a common header. The water that

## period two

# System Components

---

### notes

results from the ice melting does not leave the tank. The ice is typically stored within the same vessel that holds the heat exchanger.

Static ice storage tanks are available from several manufacturers and come in different sizes and configurations. Larger systems may use a single tank or use several smaller tanks manifolded together.

### Freeze Rate and Melt Rate

---

#### ▲ Factors:

- ◆ Surface area of heat exchanger
- ◆ Flow rate of heat-transfer fluid
- ◆ Entering temperature of heat-transfer fluid

Figure 13

While static tanks are available in several configurations and geometries, all are based on the concept that the heat-transfer fluid remains in the liquid phase at temperatures low enough—well below 32°F (0°C)—for the water inside the tank to freeze. The heat-transfer fluid flows through the tubes of the heat exchanger.

When heat is transferred from the water (storage medium) inside the tank to the heat-transfer fluid, the water freezes. The rate at which the water inside the tank freezes is called the **freeze rate**. When heat is transferred from the heat-transfer fluid to the ice inside the tank, the ice melts. The rate at which the ice melts is called the **melt rate**. The freeze rate and melt rate of a static ice storage tank depend on the surface area of the heat exchanger, the rate at which the heat-transfer fluid flows through the tubes inside the tank, and the entering fluid temperature.

Ice storage tanks are available in different sizes, and the surface area of the heat exchanger is typically constant for a given tank size and configuration. Therefore, varying the fluid flow rate or changing the entering fluid temperature are the only means of varying the freeze rate or melt rate of a given tank design. Alternatively, storage tank manufacturers offer different designs that are capable of achieving a more-rapid melt rate.



# period two

## System Components

### notes

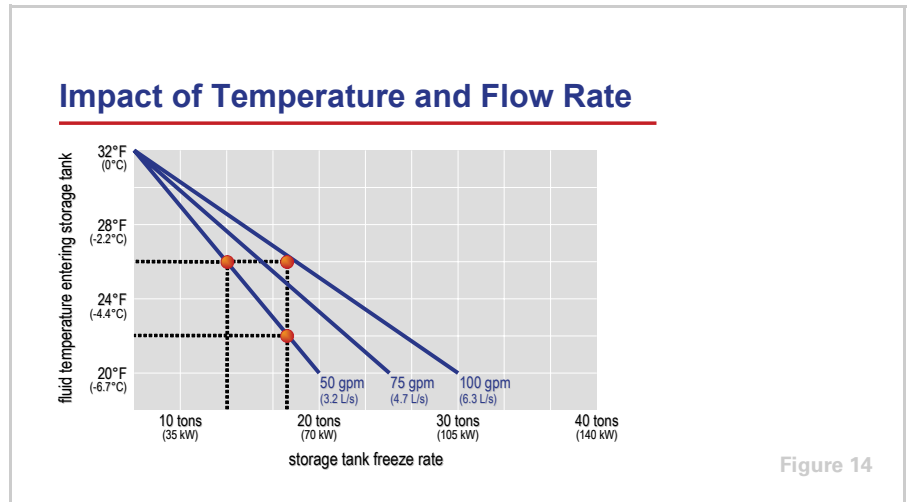

Figure 14

The chart in Figure 14 depicts the freeze rate of an example ice storage tank. When the entering fluid temperature is 26°F (-3.3°C), and the fluid flow rate is 50 gpm (3.2 L/s), the freeze rate of this tank is 13.3 tons (46.8 kW). By reducing the entering fluid temperature to 22°F (-5.6°C), with the same fluid flow rate, the freeze rate increases to about 17 tons (59.8 kW). However, to achieve the equivalent, higher freeze rate with the original entering fluid temperature of 26°F (-3.3°C) would require nearly doubling the fluid flow rate.

Increasing the flow rate of the heat-transfer fluid increases pump energy use. Lowering the temperature entering the tank increases chiller energy use. Well-designed ice storage systems balance these two competing concerns.

Between these two approaches, lowering the entering fluid temperature is typically the most effective means of increasing the freeze rate. It usually results in a system that has a lower installed cost and uses less energy than a system with a higher fluid flow rate. In this example, the freeze rate was increased 28 percent by lowering the entering fluid temperature only 4°F (2.3°C).

Varying the flow rate through the tank, however, is commonly used to adjust the melt rate when the tanks are being used to satisfy the building cooling load. This will be discussed further in Period Five.

period two  
**System Components**

---

## notes

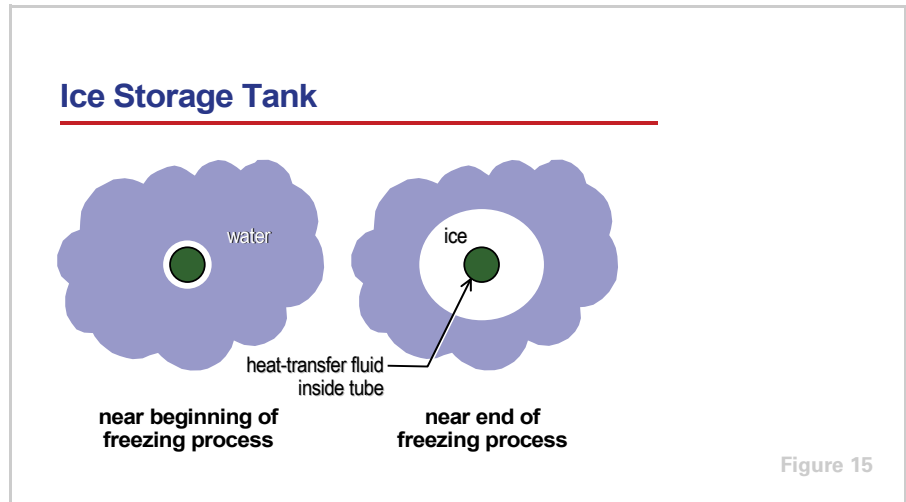

The effectiveness of heat transfer inside a static ice storage tank varies throughout the freezing process. The water first freezes on the outer surface of the heat-exchanger tubes, then continues to freeze outward.

Heat is transferred from the water surrounding the ice-covered tubes, through the ice to the heat-transfer fluid inside the tubes. Near the beginning of the freezing process, the ice is very thin and has little impact on heat transfer. As freezing progresses, however, the ice becomes thicker and significantly impedes heat transfer.

In order to maintain the same freeze rate with this degrading heat transfer, the temperature of the fluid entering the ice storage tank must decrease near the end of the freezing process. Manufacturers of ice storage tanks typically provide an average entering-fluid temperature and a final entering-fluid temperature for each specific application.

## period two

# System Components

## notes

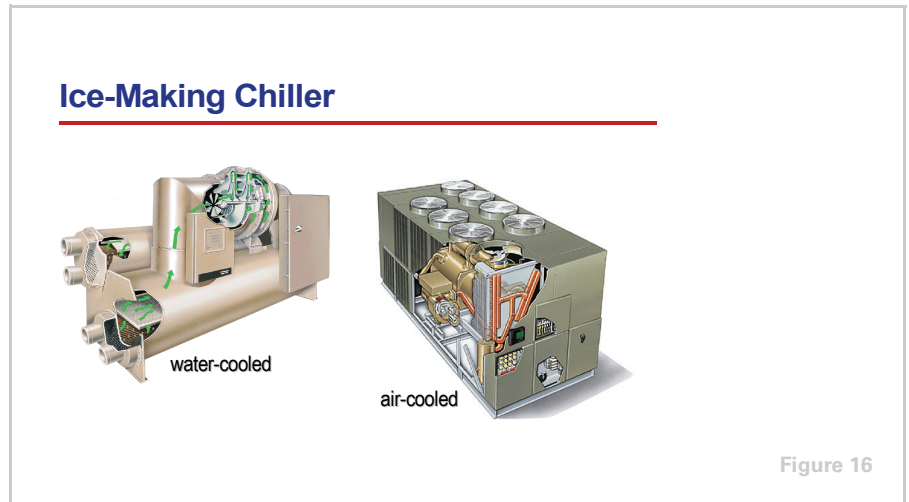

### Ice-Making Chiller

In many ice storage systems, the same chiller that is used to cool the building can also be used to make ice. The dual roles of an ice-making chiller can substantially reduce the installed cost of the system. However, an ice-making chiller is more than a conventional chiller with two different leaving-fluid temperature setpoints.

**Ice-Making Chiller**

---

Cooling-only chiller	Ice-making chiller
<ul style="list-style-type: none"> <li>◆ Increases or decreases capacity in response to changing cooling load</li> <li>◆ Controlled to maintain <i>leaving-fluid</i> temperature at setpoint</li> </ul>	<ul style="list-style-type: none"> <li>◆ Operates at maximum capacity while in ice-making mode</li> <li>◆ Operates until <i>entering-fluid</i> temperature drops below lower limit</li> </ul>

Figure 17

A conventional, cooling-only chiller increases or decreases its capacity, in response to the changing cooling load, to maintain the *leaving-fluid* temperature at a desired setpoint.

An ice-making chiller operates at maximum capacity when in ice-making mode. It continues to operate at maximum capacity until the *entering-fluid* temperature drops below a predetermined lower limit. This limit indicates that all of the water inside the ice storage tanks has been frozen.

## period two

# System Components

### notes

While a conventional, cooling-only chiller and an ice-making chiller may appear to be identical, the control of the compressors (and condenser fans, if the chiller is air-cooled) is different. These control algorithms—which allow the chiller to operate reliably at the significantly lower temperatures required in ice-making mode—can be embedded in the control panel of the chiller or programmed in a system-level controller.

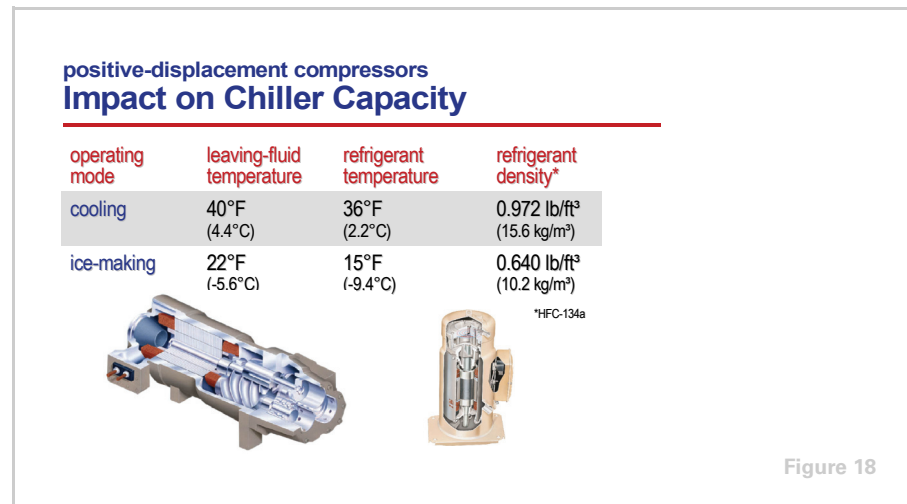

When operating in ice-making mode, an ice-making chiller has less cooling capacity than when it operates in conventional cooling mode. This loss of capacity is due to the change in density of the refrigerant vapor at the different temperatures.

For example, when operating in cooling mode, producing 40°F (4.4°C) fluid, the temperature of the refrigerant inside the chiller evaporator might be 36°F (2.2°C). At this temperature, the density of saturated HFC-134a vapor is 0.972 lb/ft<sup>3</sup> (15.6 kg/m<sup>3</sup>). When operating in ice-making mode, however, with the chiller producing 22°F (-5.6°C) fluid, the refrigerant temperature might be 15°F (-9.4°C). At this lower temperature, the density of the refrigerant vapor drops to 0.640 lb/ft<sup>3</sup> (10.2 kg/m<sup>3</sup>).

The capacity of the chiller is a function of the mass flow rate of refrigerant being “pumped” by the compressor. Helical-rotary, scroll, and reciprocating compressors are all positive-displacement compressors. This means that the suction, or intake, volume of the compressor is constant. Because the volume is constant, when the density of the refrigerant decreases, the mass of refrigerant vapor drawn from the evaporator into the compressor decreases, thereby reducing capacity.

In ice-making mode, chiller capacity is reduced by approximately the ratio of this change in refrigerant density. In this example, the capacity of the chiller operating in ice-making mode is approximately 66 percent of its capacity when operating in conventional cooling mode.

## period two

# System Components

## notes

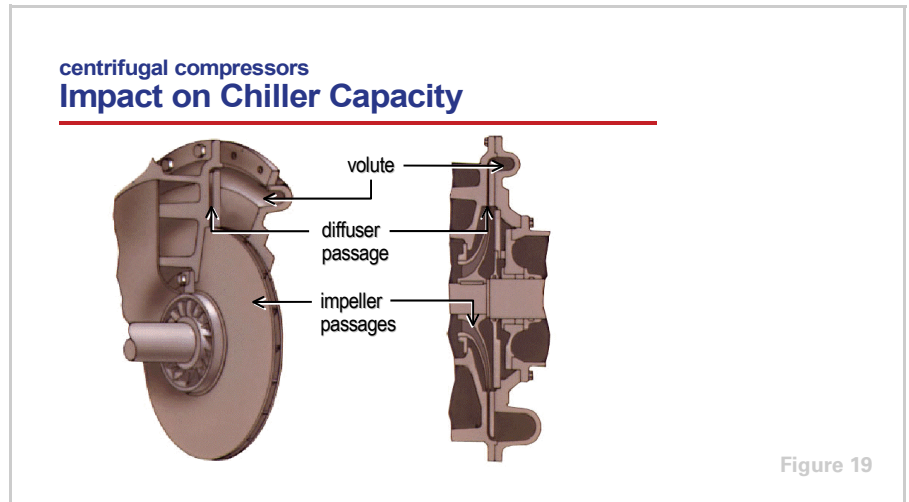

A centrifugal compressor operates on the principle of converting kinetic energy to static energy, to increase the pressure and temperature of the refrigerant vapor.

Again, the capacity of the chiller is a function of the mass flow rate of refrigerant being “pumped” by the compressor. The maximum volumetric flow rate of refrigerant—expressed in terms of  $\text{ft}^3/\text{min}$  (L/s)—that can be “pumped” through a centrifugal compressor is fixed for a given impeller size. Because the volumetric flow rate is constant, as the density of the refrigerant vapor decreases, the mass flow rate of refrigerant drawn from the evaporator into the compressor decreases.

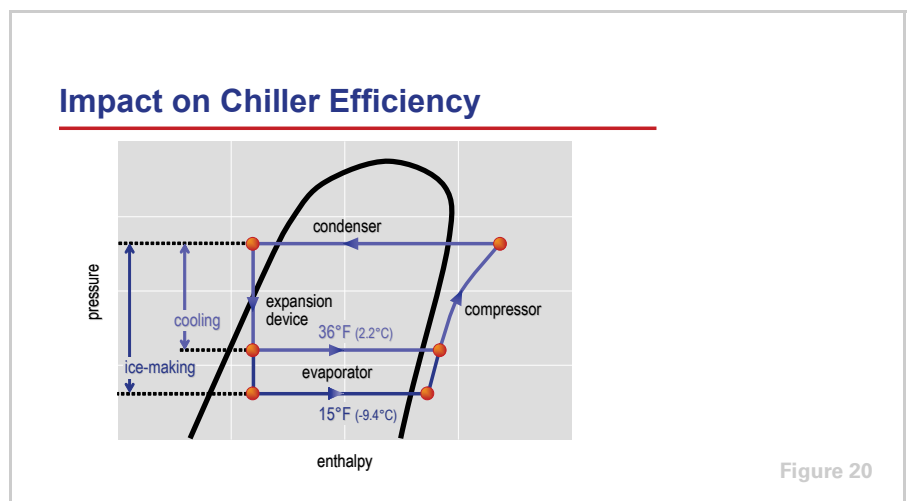

Additionally, when operating in ice-making mode, an ice-making chiller will generally be less efficient than when it operates in cooling mode.

## period two

# System Components

### notes

As mentioned previously, producing the colder fluid temperature requires the temperature (and, therefore, the pressure) of the refrigerant inside the chiller evaporator to be lower. This increases the compressor lift—the difference in refrigerant pressure between the evaporator and condenser—and requires the compressor to work harder.

The increased compressor lift, and the decreased capacity, both generally cause the chiller to operate less efficiently during ice-making mode than when operating in conventional cooling mode.

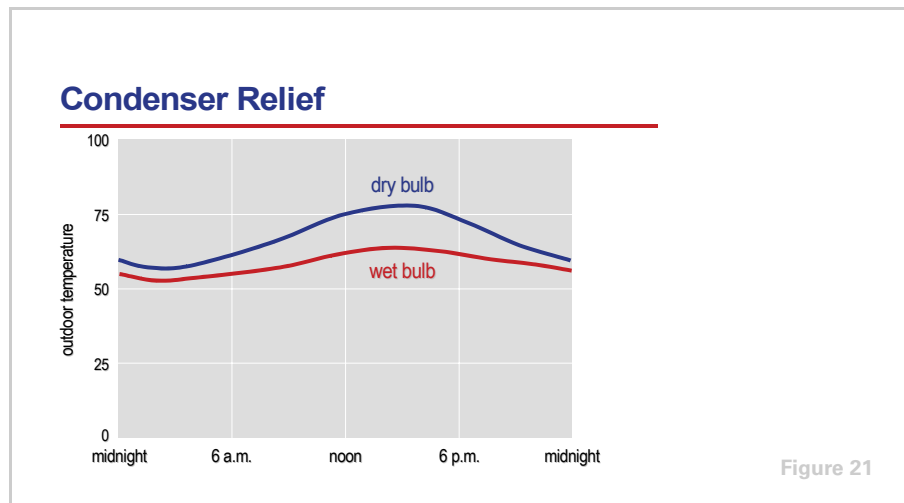

Fortunately, however, the capacity and efficiency loss is generally less severe because the temperature (and, therefore, the pressure) of the refrigerant inside the chiller condenser is typically lower when the chiller is operating in ice-making mode.

The refrigerant condensing pressure in an air-cooled chiller is dependent on the outdoor dry-bulb temperature. The condensing pressure in a water-cooled chiller that is connected to a cooling tower is dependent on the outdoor wet-bulb temperature.

During the nighttime hours, when the chiller is most likely to operate in ice-making mode, both the outdoor dry-bulb and wet-bulb temperatures are typically several degrees lower than during the day. This allows the refrigerant condensing pressure to also decrease, which allows the chiller to regain some of the capacity and efficiency it lost by producing colder fluid temperatures.

# period two

## System Components

### notes

**Heat-Transfer Fluid**

- ▲ Ethylene glycol
- ▲ Propylene glycol

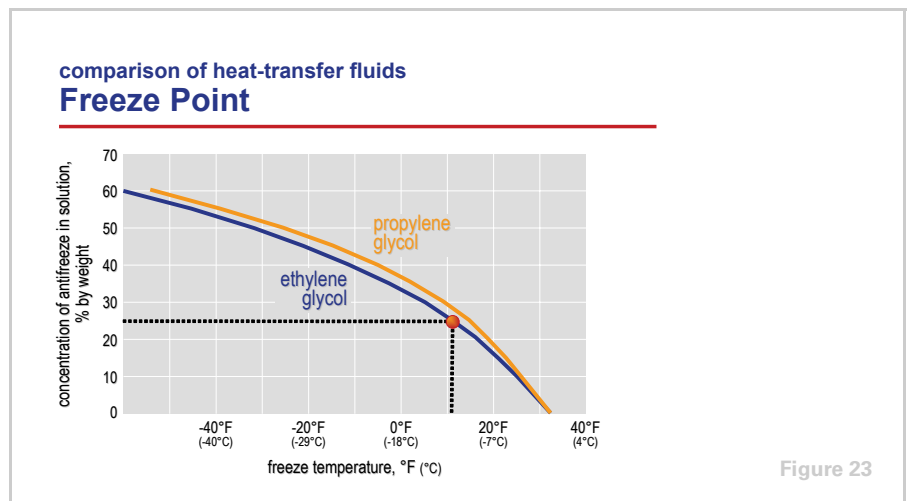

Figure 22

**Heat-Transfer Fluid**

Finally, glycol-based ice storage systems require a heat-transfer fluid that remains in the liquid phase at temperatures below the freezing point of water.

Typically, the heat-transfer fluid is a mixture of water and antifreeze, which lowers the freezing point of the solution. While there are other choices, the most common antifreezes used in glycol-based ice storage systems are ethylene glycol and propylene glycol.



Propylene glycol offers slightly less freeze protection than ethylene glycol. Therefore, a higher concentration of propylene glycol is required to achieve the same freeze point.

When using ethylene glycol, a water-and-antifreeze solution that has a concentration of 25 percent (by weight) ethylene glycol results in a freeze point

## period two

# System Components

### notes

sufficiently below that of water to allow reliable operation in a typical ice storage system. When using propylene glycol, a 30 percent concentration is typical.

In addition to the freeze point, other physical properties of these heat transfer fluids also differ from water.

**comparison of heat-transfer fluids**  
**Heat-Transfer Properties**

solution	freeze point	specific heat	viscosity
water	32°F (0°C)	1.0 Btu/lb-°F (4.2 kJ/kg-°K)	1.5 cp (1.5 mPa-sec)
ethylene glycol (25%)	11.4°F (-11.7°C)	0.90 Btu/lb-°F (3.77 kJ/kg-°K)	3.2 cp (3.2 mPa-sec)
propylene glycol (30%)	9.3°F (-12.8°C)	0.92 Btu/lb-°F (3.85 kJ/kg-°K)	5.2 cp (5.2 mPa-sec)

fluid temperature = 40°F (4.4°C)

Figure 24

Because propylene glycol has a slightly higher specific heat than ethylene glycol, it would appear that the fluid flow rate required with propylene glycol would be slightly less. Unfortunately, this does not equate to reduced pumping power or better heat transfer, because propylene glycol has a substantially higher viscosity than ethylene glycol. This means that a system using propylene glycol will require larger pumps, and potentially larger cooling coils, due to the loss of heat transfer.

For most ice storage systems, the preferred heat transfer fluid is comprised of 25 percent ethylene glycol and 75 percent water. It provides sufficient freeze protection and minimizes the negative impact on heat transfer in the other system components. As well as being a stable fluid with a long life, ethylene glycol is non-corrosive and is therefore safe to use with coils, pipes, and chiller components when properly inhibited.

For applications in which oral toxicity is a concern (e.g., food processing or pharmaceuticals), propylene glycol is commonly used. Propylene glycol is a food-grade product, but has poor heat-transfer characteristics at the temperatures required for ice storage. Therefore, propylene glycol cannot be substituted for ethylene glycol without re-engineering the other components of the system. In these applications, it may be beneficial to consider other choices, such as potassium formate.



# period two

## System Components

### notes

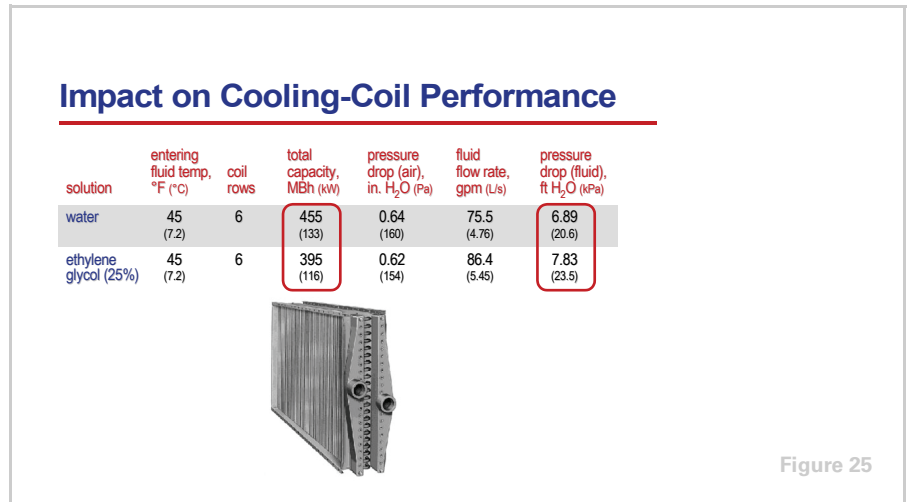

The negative impact on heat transfer that results from adding antifreeze to the heat-transfer fluid can be illustrated by examining the performance of a cooling coil. Figure 25 shows the performance of an example cooling coil that contains six rows of tubes with 118 fins/ft. This coil has been selected for an airflow of 12,000 cfm (5,663 L/s) and a total cooling capacity of 455 MBh (133 kW).

Using water alone (without antifreeze), this coil requires 75.5 gpm (4.76 L/s) of 45°F (7.2°C) water to provide the desired capacity. At this flow rate, the fluid pressure drop through the tubes is 6.89 ft H<sub>2</sub>O (20.6 kPa).

Adding ethylene glycol to the water degrades the heat-transfer performance of this coil—reducing its capacity by 13 percent, to 395 MBh (116 kW)—and increases the fluid pressure drop by 14 percent, to 7.83 ft H<sub>2</sub>O (23.5 kPa).

Both performance losses are attributed to the lower specific heat and higher viscosity (which reduces the Reynolds Number) of the water-and-glycol solution. However, there are ways to recover some of this lost capacity through coil selection and system design.

## period two

# System Components

### notes

#### Impact on Cooling-Coil Performance

solution	entering fluid temp, °F (°C)	coil rows	total capacity, MBh (kW)	pressure drop (air), in. H <sub>2</sub> O (Pa)	fluid flow rate, gpm (L/s)	pressure drop (fluid), ft H <sub>2</sub> O (kPa)
water	45 (7.2)	6	455 (133)	0.64 (160)	75.5 (4.76)	6.89 (20.6)
ethylene glycol (25%)	45 (7.2)	6	395 (116)	0.62 (154)	86.4 (5.45)	7.83 (23.5)
ethylene glycol (25%)	45 (7.2)	8	455 (133)	0.83 (208)	86.4 (5.45)	9.81 (29.3)
ethylene glycol (25%)	45 (7.2)	6	455 (133)	0.65 (162)	120.7 (7.62)	14.3 (42.8)

Figure 26

If this coil is being selected for a new installation, the desired capacity can be achieved by increasing the surface area of the coil. In this example, increasing the number of rows from six to eight returns the capacity of the coil to the desired 455 MBh (133 kW). This approach, however, also increases the airside pressure drop (which increases fan energy use and may require the selection of a larger fan motor) and increases the fluid-side pressure drop (which increases pump energy use and may require the selection of a larger pump motor).

An alternate approach to achieve the desired capacity is to increase the fluid flow rate through the coil—to 120.7 gpm (7.62 L/s) in this example. This avoids any increase in airside pressure drop, but results in an even higher fluid-side pressure drop, and more pump energy use, than the previous choice.

## period two

# System Components

### notes

#### Impact on Cooling-Coil Performance

solution	entering fluid temp, °F (°C)	coil rows	total capacity, MBh (kW)	pressure drop (air), in. H <sub>2</sub> O (Pa)	fluid flow rate, gpm (L/s)	pressure drop (fluid), ft H <sub>2</sub> O (kPa)
water	45 (7.2)	6	455 (133)	0.64 (160)	75.5 (4.76)	6.89 (20.6)
ethylene glycol (25%)	45 (7.2)	6	395 (116)	0.62 (154)	86.4 (5.45)	7.83 (23.5)
ethylene glycol (25%)	45 (7.2)	8	455 (133)	0.83 (208)	86.4 (5.45)	9.81 (29.3)
ethylene glycol (25%)	45 (7.2)	6	455 (133)	0.65 (162)	120.7 (7.62)	14.3 (42.8)
ethylene glycol (25%)	40 (4.4)	6	455 (133)	0.64 (160)	84.1 (5.31)	7.52 (22.5)

Figure 27

Typically, the best approach for achieving the desired capacity is to decrease the temperature of the heat-transfer fluid entering the cooling coil. Using the original coil, the desired capacity can be restored by reducing the entering fluid temperature from 45°F (7.2°C) to 40°F (4.4°C). This option has no impact on the airside pressure drop, and results in a lower fluid flow rate than the previous three selections. The lower flow rate helps to offset the impact of adding antifreeze to the heat-transfer fluid, reducing the fluid-side pressure drop and reducing system pumping energy.

Producing a colder fluid temperature, however, makes the chiller work harder and use more energy. The key is to strike an optimal balance between these competing concerns.

Reducing the entering fluid temperature has proven to be the least expensive means, in terms of both installed cost and energy cost, of recovering the cooling-coil capacity lost when a water-and-antifreeze heat-transfer fluid is used. And, this approach applies to both new installations and retrofit situations.

## period two

# System Components

### notes

#### Impact on Cooling-Coil Performance

solution	entering fluid temp, °F (°C)	coil rows	total capacity, MBh (kW)	pressure drop (air), in. H <sub>2</sub> O (Pa)	fluid flow rate, gpm (L/s)	pressure drop (fluid), ft H <sub>2</sub> O (kPa)
water	45 (7.2)	6	455 (133)	0.64 (160)	75.5 (4.76)	6.89 (20.6)
ethylene glycol (25%)	45 (7.2)	6	395 (116)	0.62 (154)	86.4 (5.45)	7.83 (23.5)
ethylene glycol (25%)	45 (7.2)	8	455 (133)	0.83 (208)	86.4 (5.45)	9.81 (29.3)
ethylene glycol (25%)	45 (7.2)	6	455 (133)	0.65 (162)	120.7 (7.62)	14.3 (42.8)
ethylene glycol (25%)	40 (4.4)	6	455 (133)	0.64 (160)	84.1 (5.31)	7.52 (22.5)
ethylene glycol (25%)	38 (3.3)	6	455 (133)	0.64 (160)	76.8 (4.22)	6.41 (19.2)

Figure 28

Lowering the entering fluid temperature even farther, to 38°F (4.4°C) in this example, can provide further benefits. The improvement in heat-transfer performance results in an even lower fluid flow rate, and a lower fluid-side pressure drop than the original coil selection, which was based on water. This actually results in less pump power than the system that did not contain glycol.

Alternatively, the lower entering-fluid temperature could allow the coil to be re-selected with fewer fins, instead of lowering the fluid flow rate. This would decrease the cost of the coil and result in a lower airside pressure drop, which reduces fan energy use.

Finally, a colder entering-fluid temperature creates the opportunity to lower the supply-air temperature. Cold-air systems can allow selection of smaller air handlers, smaller VAV terminals, and smaller ducts, and they reduce supply-fan energy use.

## period two

# System Components

### notes

#### Impact on Chiller Performance

- ▲ Select heat-transfer fluid with low viscosity
- ▲ Keep concentration of antifreeze as low as possible



Figure 29

The loss of heat transfer due to adding antifreeze to the heat-transfer fluid also has a negative impact on the capacity and efficiency of the chiller. Similar to the cooling coil, this degradation is attributed to the lower specific heat and higher viscosity of the heat-transfer fluid.

The first recommendation is to select an antifreeze that has as low a viscosity as possible. As shown in Figure 24 on page 18, the viscosity of ethylene glycol is much lower than the viscosity of propylene glycol at the temperatures typically encountered in an ice storage system.

The second recommendation is to keep the concentration of antifreeze to the lowest acceptable level. As mentioned previously, a water-and-antifreeze solution that has a concentration of 25 percent ethylene glycol is generally preferred for ice storage systems. When using propylene glycol, a 30 percent concentration is typically sufficient.

## period three

# Design Process

---

### notes

### Ice Storage Systems

*period three*

**Design Process**

Figure 30

Period Three discusses the process of designing an ice storage system.

*ice storage system*

### Design Process

- 1. Define the mission**
- 2. Determine ice storage capacity**
- 3. Select the storage tanks and chillers**

Figure 31

The first step is to clearly define the mission of the ice storage system. This mission statement needs to clarify which of the potential benefits are desired, and if more than one benefit is desired, which is most important.

The second step in designing an ice storage system is to define the required storage capacity by evaluating the specific application in terms of the space available for the tanks, the impact on the overall installed cost of the system, and the impact on life-cycle cost.

And, the third step is to actually select the storage tanks and chillers.

## period three

# Design Process

### notes

#### 1. Define the Mission

- ▲ Which of the potential benefits of ice storage are more important for the project?
- ▲ Priority of these benefits will dictate how the system is designed and controlled
  - ◆ Example:  
An ice storage system that is used to minimize on-peak electrical consumption may have more storage capacity than a system that is designed to reduce installed cost

Figure 32

#### Define the Mission

Should the ice storage system be sized for full- or partial-storage capacity? If a partial-storage system is used, what is the optimum storage capacity? Should the system be designed for peak shaving or load shifting?

Before determining how much ice storage capacity is optimum for a given application, one must have a clear understanding of which benefits of ice storage are desired for the given project. Some design engineers call this the mission statement, or the design intent. A clear and definitive mission statement helps direct how the ice storage system is to be designed and controlled.

In some installations, maximizing one benefit may negate one or more of the other potential benefits. The mission statement needs to clarify which of the potential benefits are desired, and if more than one benefit is desired, which is most important.

For example, if the mission is to minimize on-peak electrical consumption (kWh), the system may be designed with lots of ice storage capacity, which may increase the overall installed cost. On the other hand, if the mission is to reduce installed cost, the system will likely be designed with a smaller amount of storage capacity. Downsizing the chiller, and financial incentives from the utility company, may lower the overall installed cost, but the system will probably not reduce the on-peak electrical consumption as much as a system with more storage capacity.

Realize, however, that this mission statement may need to be revised in the future as electrical rates or building use change. A good design will allow the system to adapt after installation.

period three  
**Design Process**

---

## notes

### **2. Determine Ice Storage Capacity**

---

- ▲ Available space
- ▲ Installed cost
- ▲ Life-cycle cost

Figure 33

#### **Determine Ice Storage Capacity**

After the mission of the ice storage system has been clearly defined, the design engineer can determine the total ice storage capacity that best meets the mission.

The storage capacity is influenced by the space available for the tanks, the impact on the overall installed cost of the system, and the impact on life-cycle cost.

Limited space for installation may dictate that a system be designed with less storage capacity, even though more capacity could be economically justified. To reduce the impact of space constraints, make use of basements, parking garages, or the grounds surrounding the building. Tank manufacturers offer various configurations and packaging arrangements to accommodate indoor or outdoor and above-grade or underground installations.



## period three

# Design Process

## notes

### Economics

#### ▲ Account for all cost additions ...

- ◆ Storage tanks
- ◆ Enhancements to system-level controls
- ◆ Impact of heat-transfer fluid

#### ... and cost reductions

- ◆ Downsized chiller, pumps, or cooling tower
- ◆ Lower-cost cooling coils
- ◆ Downsized supply-fan motor
- ◆ Smaller pipes

#### ▲ Optimize ice storage capacity

- ◆ Perform an hourly life-cycle cost analysis

Figure 34

How much ice storage capacity can the owner afford? The financial success of an ice storage system requires proper accounting for all added costs and cost reductions.

Ice storage tanks, enhancements to the system-level controls, and the impact of adding antifreeze to the heat-transfer fluid each add to the installed cost of the system. However, there may be several offsetting cost reductions. Depending on the system design, equipment may be downsized. This could include the chiller, pumps, or cooling tower. If the equipment is downsized, the electrical service to the building might also be smaller, allowing for further installed-cost reductions.

In addition, because ice storage systems typically supply fluid to the cooling coils at a colder temperature than conventional chilled-water systems, there may be other secondary cost benefits. Wider fin spacing reduces the cost of the cooling coils and lowers fan static pressure, which could possibly allow the fan motor to be downsized. Colder fluid temperatures may also allow the use of lower fluid flow rates, which might result in smaller pipe sizes. Finally, colder fluid temperatures also afford the opportunity to lower the supply-air temperature. Cold-air systems can allow selection of smaller air handlers, smaller VAV terminals, and smaller ducts, and they reduce supply-fan energy.

In addition to installed cost, ice storage systems can achieve substantial utility-cost savings. However, as more ice storage capacity is added to the system, the financial benefit of that additional capacity diminishes. A system driven by installed cost, or payback, will likely include less storage capacity than a system that is evaluated based on life-cycle cost. Computerized, hourly energy-analysis programs help perform these life-cycle cost analyses.

## period three

# Design Process

### notes

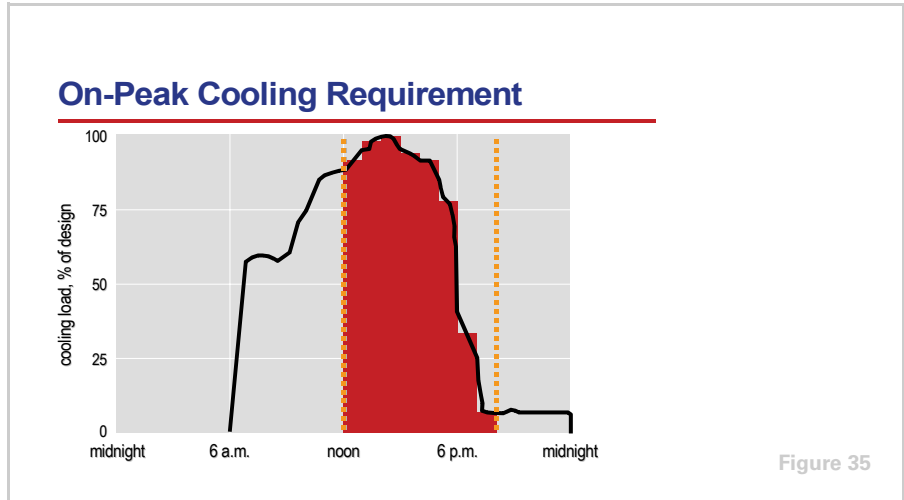

Two different cooling-load profiles are helpful when determining the ice storage capacity of the system. The first is the 24-hour cooling-load profile for the design day. This is useful for balancing chiller capacity, tank freeze rate, and tank melt rate to ensure that the cooling loads can be satisfied for each hour of the design (or worst-case) day.

If the mission of the ice storage system is to reduce the on-peak energy consumption, the first step is to determine the total cooling requirement for the on-peak period. This is determined by calculating the cooling loads, in tons (kW), for each hour of the on-peak period, and then adding them together. The result will be the total, on-peak cooling requirement expressed in ton-hours (kWh).

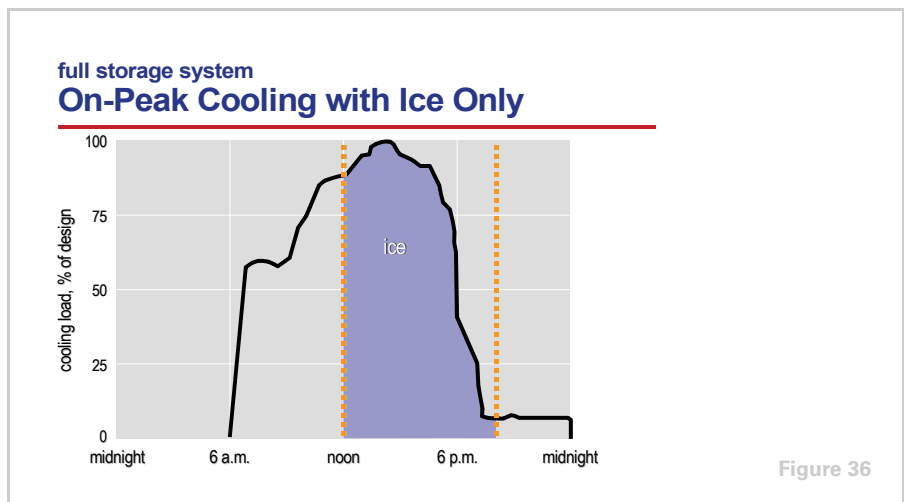

As discussed in Period One, one approach is to design a full-storage system with sufficient ice storage capacity to satisfy the entire on-peak cooling

## period three

# Design Process

### notes

requirement. This would allow the chiller to be turned off altogether during the on-peak period.

For most installations, however, the installed cost or space requirements of a full-storage system may not be feasible.

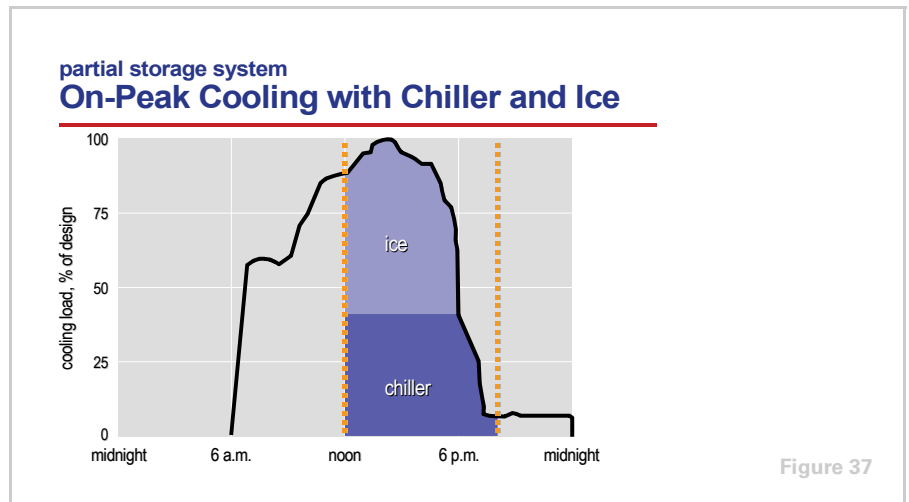

On the design day, a partial-storage system uses both the chiller and the ice storage tanks to satisfy the on-peak cooling requirement. The chiller operates at a reduced capacity, and the cooling loads above this capacity are satisfied by melting ice. On less-severe (or part load) days, however, the system may have sufficient storage capacity to satisfy the entire on-peak cooling requirement by melting the ice only.

In the example shown in Figure 37, the chiller operates at a constant capacity, equal to about 40% of the design cooling load, during each hour of the on-peak period. The ice storage tanks satisfy the remaining loads.

If the mission of the ice storage system is to keep the chiller below a certain size—either due to limited space available for installation or due to limited electrical service (amperes) to the building—the maximum capacity of the chiller will be defined by those limitations. Therefore, the system must have sufficient ice storage capacity to satisfy the portion of the cooling loads that is greater than the cooling capacity of the chiller.

## period three

# Design Process

---

### notes

#### determine ice storage capacity **Hourly Energy Analysis**

---



Figure 38

If the mission of the ice storage system is to reduce utility costs for a reasonable investment, determining the optimal storage capacity in a partial-storage system is more difficult.

Computerized, hourly energy-analysis programs are extremely helpful when performing life-cycle analyses for systems with varying amounts of ice storage capacity. This type of analysis, however, can be very time-consuming if not constrained by some initial limits.

When available space is not a limiting factor, and the electrical rates during the on-peak period are very high, a system with lots of storage capacity (possibly even a full-storage system) may be justified. Even so, financial incentives from electric utility companies are often required to justify a full-storage system.

When the utility rates are more modest, however, an attractive financial return can usually be achieved when the ice storage capacity equals 20 percent to 40 percent of the on-peak cooling requirement, in ton-hrs (kWh), for the design day.

## period three

# Design Process

### notes

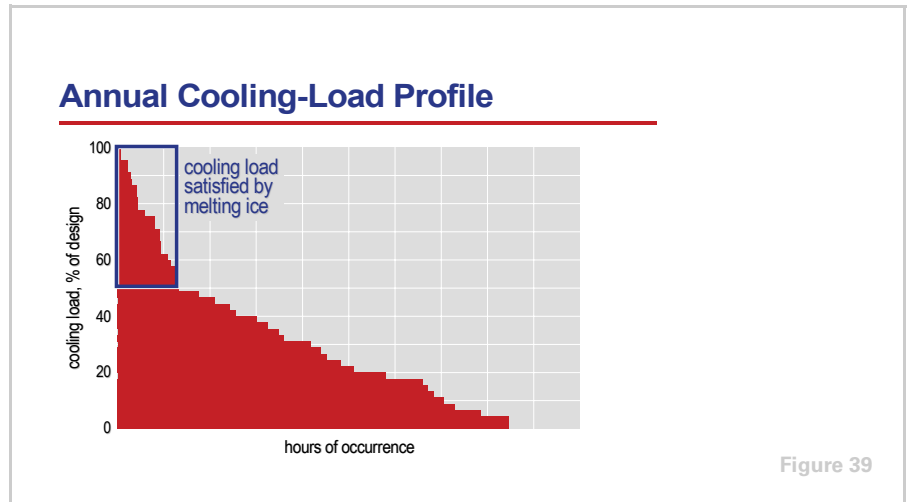

The second cooling-load profile that is helpful for determining ice storage capacity is the annual cooling-load profile. This chart displays how the building cooling load (on the Y axis) varies throughout the year, and the total number of hours (on the X axis) each load occurs. This profile can be useful to balance the installed cost of the storage tanks with the utility-cost savings.

Adding more ice storage capacity allows the system to satisfy more of the cooling load (stretching the box downward on the annual cooling-load profile chart), lowering the on-peak electrical demand (kW). However, this additional storage capacity increases the installed cost (the area of the bars inside the box increases, stretching the box to the right on the chart) and requires more space.

The installed cost of ice storage is basically linear. That is, the last ton-hr (kWh) of storage capacity added to a system costs the same as the first ton-hr (kWh) of capacity. The financial benefit of additional storage capacity, however, is not linear.

For example, the first ton-hr (kWh) of storage capacity added to the system may be used every day of the cooling season. But the last ton-hr (kWh) of capacity added may be used for only a few days of the year. Thus, the financial benefit of adding that last ton-hr (kWh) of capacity is much less than the financial benefit of adding the first ton-hr (kWh). For every project, there is a point of diminishing return, when adding more ice storage capacity is no longer economically justified.

## period three

# Design Process

## notes

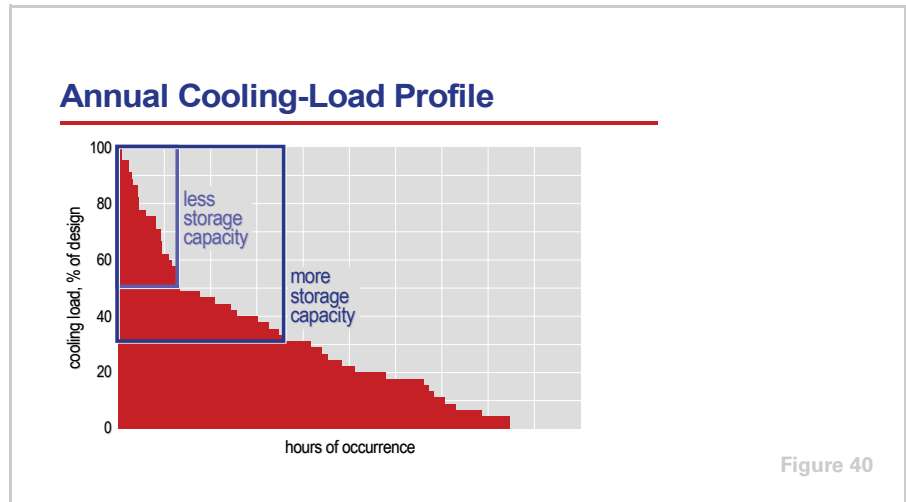

Initially, the box stretches downward faster than it stretches to the right, indicating that the on-peak demand drops faster than the installed cost increases.

However, as more storage capacity is added, the box begins to stretch to the right faster than it stretches downward. This indicates that the installed cost increases faster than the on-peak demand drops. At this point, the financial justification of adding more ice storage capacity becomes more difficult.

This annual cooling-load profile, however, does not depict the cost of electricity. It may be that additional ice storage capacity could be financially justified because of high, on-peak electrical consumption (kWh) rates or demand (kW) charges. Again, computerized, hourly energy-analysis programs are very helpful when determining the optimum storage capacity for a partial-storage system.

## period three

# Design Process

## notes

### 3. Select Storage Tanks and Chillers

- ▲ Melt rate
- ▲ Freeze rate
- ▲ Fluid flow rates
- ▲ Fluid temperatures

Figure 41

#### Select Storage Tanks and Chillers

After the storage capacity has been determined, the design engineer can select the storage tanks and chillers for the system.

Several factors influence this process: the required freeze rate and melt rate of the storage tanks, the fluid flow rates, and the fluid temperatures.

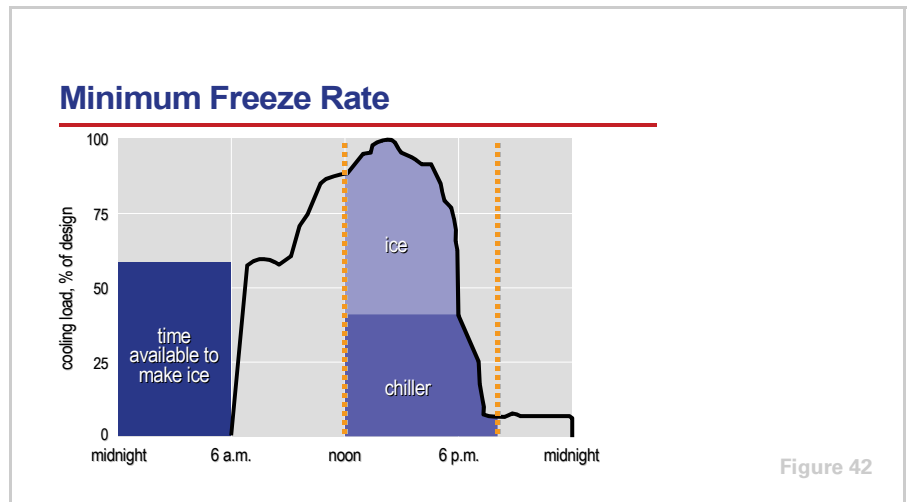

Figure 42

The ice storage tanks must be selected for a freeze rate that is fast enough to make the desired amount of ice in the time available for ice making. This minimum freeze rate also dictates the required capacity of the chiller when it operates in ice-making mode.

$$\text{minimum freeze rate} = \frac{\text{ice storage capacity}}{\text{time available for making ice}}$$

## period three

# Design Process

### notes

For this example, only six hours—between midnight and 6 a.m.—are available for ice making.

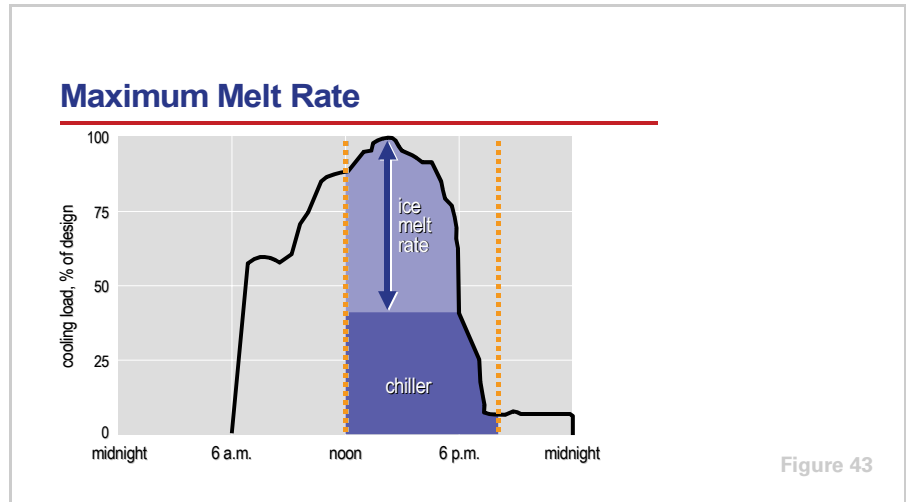

Additionally, the tanks must be selected for a melt rate that is fast enough to satisfy the portion of the design cooling load that is to be satisfied by melting the stored ice.

$$\text{maximum melt rate} = \text{design cooling load} - \text{chiller capacity at that hour}$$

For this example building, at the hour when the design (highest) cooling load occurs, the chiller provides only enough capacity to satisfy about 40 percent of the cooling load. Therefore, the melt rate of the ice storage tank must be fast enough to satisfy 60 percent of the design cooling load.



## period three

# Design Process

### notes

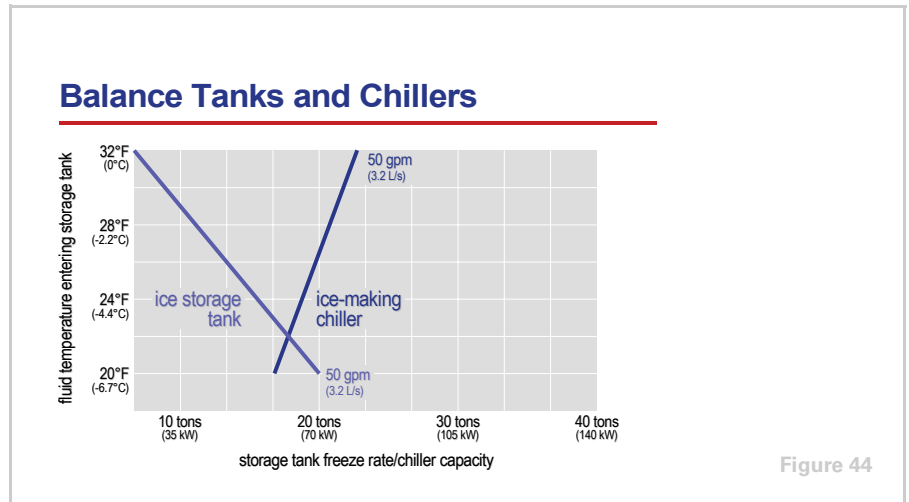

Decisions made when selecting the chillers, the ice storage tanks, and the system flow rates and temperatures are interrelated. As described in Period Two, the ice storage tank and the chiller respond differently to various fluid flow rates and temperatures. For example, as depicted in Figure 44, colder fluid temperatures increase the freeze rate of an ice storage tank, but decrease the ice-making capacity of the chiller.

Selecting the ice storage tanks for the required freeze rate and melt rate, and selecting the ice-making chiller to balance with the tank freeze rate, involves a cooperative and iterative process using the chiller selection software and ice storage tank selection software. This process of selecting the tanks and chillers can be very time-consuming if not defined by some initial limits on the flow rates and temperatures.

## period three

# Design Process

## notes

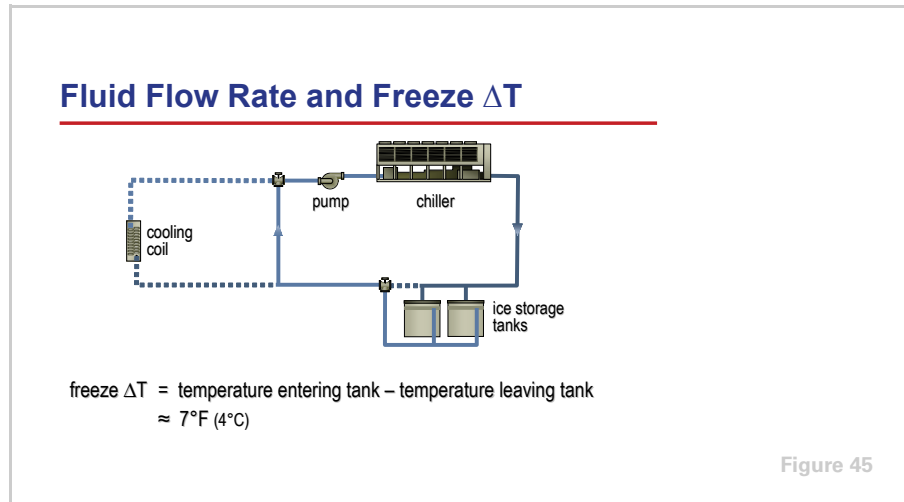

During ice-making mode, the ice storage tank is often the only load being served by the ice-making chiller. Therefore, the freeze rate of the ice storage tank must balance with the ice-making capacity of the chiller, and the fluid flow rates through both the chiller and tank are equal. The flow rate is a function of the freeze rate of the tank and the temperature rise ( $\Delta T$ ) of the heat-transfer fluid as it passes through the tank. This change in fluid temperature from the inlet to the outlet of the tank is called the **freeze  $\Delta T$** .

A smaller freeze  $\Delta T$  requires a higher fluid flow rate to achieve an equivalent freeze rate. This increases pressure drop and pump energy use. A larger freeze  $\Delta T$  requires a colder fluid temperature entering the tank. This requires the chiller to produce colder fluid, which decreases chiller capacity and increases chiller energy use. A freeze  $\Delta T$  of  $7^\circ\text{F}$  ( $4^\circ\text{C}$ ) typically strikes an optimal balance between these competing concerns.

## period three

# Design Process

## notes

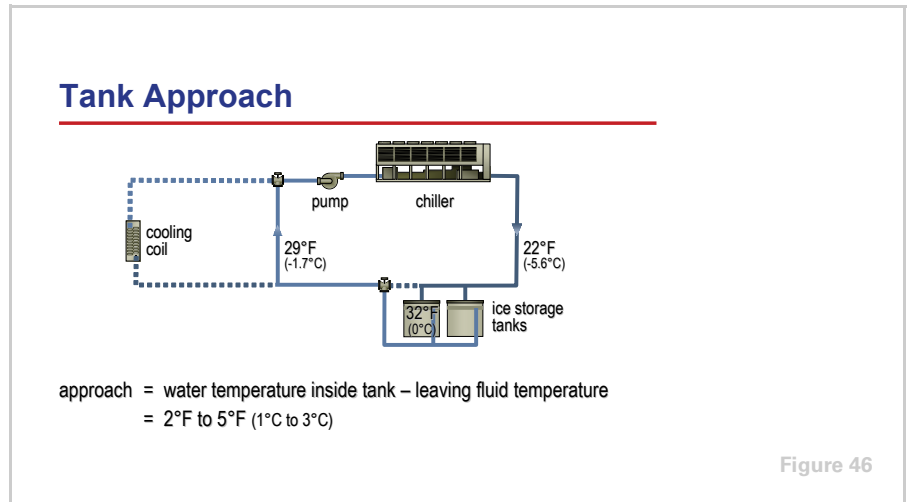

If the storage fluid inside the tank is water, the tank releases heat by changing the water from the liquid phase to the solid phase (ice). Because water freezes at 32°F (0°C), there will be no warmer temperature inside the ice storage tank during the freezing process. The temperature of the heat-transfer fluid leaving the tank will be slightly colder than 32°F (0°C). This temperature difference is called **approach**.

Approach is different for every tank design and is different for every installation. Achieving a smaller approach requires more heat-transfer surface inside the tank. This increases the cost and size of the tank. A larger approach reduces the temperature of the heat-transfer fluid leaving the tank. To achieve an equivalent freeze  $\Delta T$ , this would require the chiller to produce colder fluid, which increases chiller energy use. An approach of 2°F to 5°F (1°C to 3°C) typically strikes an optimal balance between these competing concerns.

In the example shown in Figure 46, the approach is 3°F (1.7°C). Therefore, the temperature of the fluid leaving the ice storage tank during ice-making mode will be 29°F (-1.7°C). Because the freeze  $\Delta T$  is 7°F (4°C) for this example, the temperature of the fluid entering the tank (and, therefore, leaving the chiller) needs to be 22°F (-5.6°C).

## period three

# Design Process

## notes

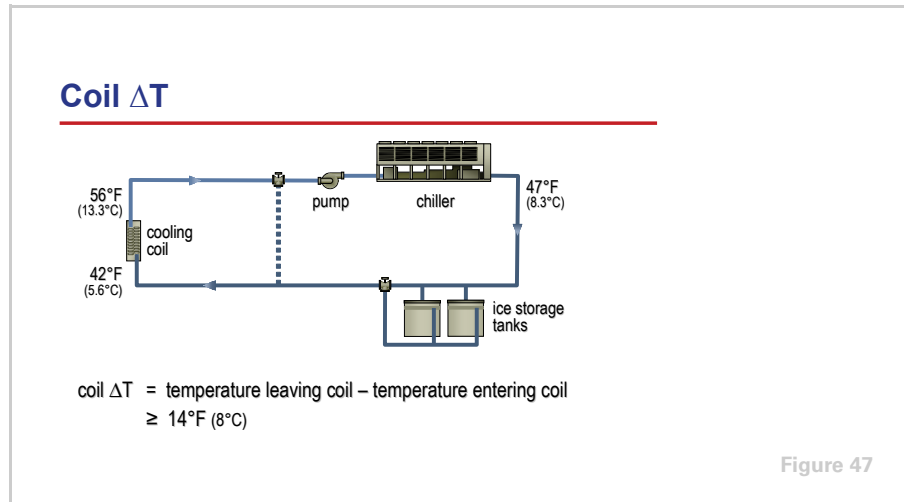

When a building cooling load exists, the heat-transfer fluid is pumped through the cooling coils, and the temperature of the fluid increases as the coil transfers heat from the warmer air to the cooler fluid. This temperature rise is called the **coil  $\Delta T$** . Ice storage systems typically perform best when the design coil  $\Delta T$  exceeds 14°F (8°C). The larger coil  $\Delta T$  results in lower flow rates, which helps to offset the impact of adding antifreeze to the heat-transfer fluid and reduces system pumping energy.

As mentioned previously, during ice-making mode, the freeze rate of the ice storage tank must balance with the ice-making capacity of the chiller. During the on-peak period, however, a partial-storage system typically uses both the cooling capacity of the chiller and the stored ice to satisfy the loads from the cooling coils. When the chiller and tank are configured in series with one another, the  $\Delta T$  across the chiller (or the tank) does not need to be the same as the coil  $\Delta T$ .

In the example shown in Figure 47, at the design cooling load the coil  $\Delta T$  is 14°F (8°C). However, the  $\Delta T$  across the chiller is only 9°F (5°C) and the  $\Delta T$  across the tank is 5°F (2.8°C).

## period three

# Design Process

## notes

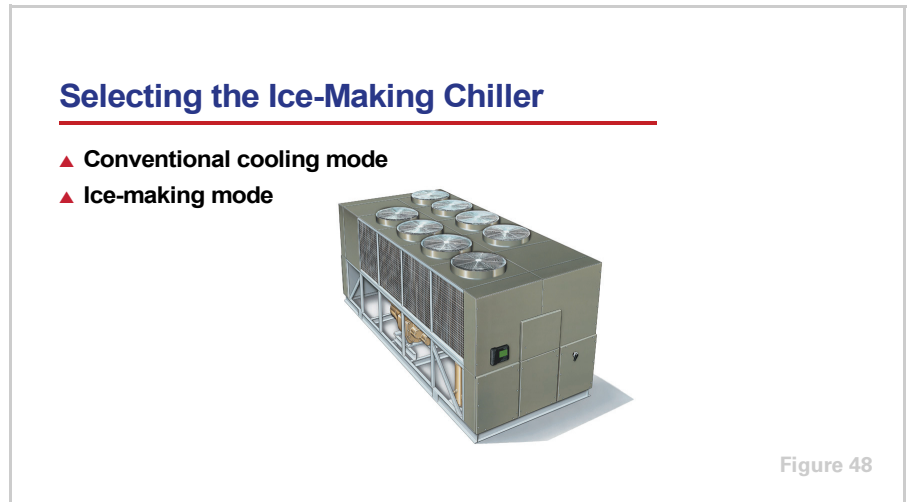

Selection of the ice-making chiller is complicated by the fact that it must perform acceptably in two different operating modes: conventional cooling and ice making.

In ice-making mode, the chiller operates at maximum capacity to ensure stable operation. Due to the decrease in refrigerant density, the compressor needs to operate at maximum capacity to keep the mass flow rate of refrigerant as high as possible. In chillers with centrifugal compressors, this helps to avoid surge. In chillers with helical-rotary compressors, this helps to properly cool the rotors. And, in chillers with scroll or reciprocating compressors, this helps prevent instability of the expansion valve.

As mentioned earlier, an ice-making chiller must be equipped with a controller that controls the compressors (and condenser fans, if the chiller is air-cooled) in such a manner as to allow it to safely operate in both modes.

Additionally, it is typically advantageous to freeze the water inside the ice storage tank as quickly as possible. This minimizes the energy used by the ancillary equipment, such as pumps, condenser fans, or cooling tower fans.

## period three

# Design Process

## notes

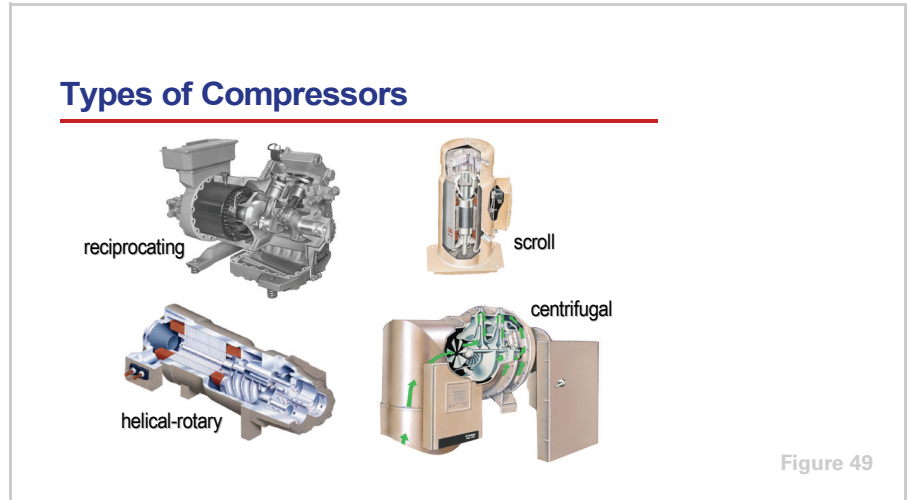

Chillers that include helical-rotary, scroll, or reciprocating compressors are typically suitable for ice-making duty without modification. Again, these positive-displacement compressors will operate at reduced capacity and reduced efficiency when producing colder fluid temperatures during ice-making mode.

A centrifugal chiller, however, must be specifically selected for ice-making duty. Because of the increased compressor lift—the difference in refrigerant pressure between the evaporator and condenser—that occurs during ice-making mode, the impeller of a centrifugal compressor will need to generate a higher-than-normal tip speed. This will likely require the selection of a larger-diameter impeller than would be needed for operation in cooling mode. This often results in less-than-optimal efficiency when the chiller operates in conventional cooling mode.

## period three

# Design Process

### notes

#### selecting the ice-making chiller **Ice-Making Mode**

##### ▲ **Verify chiller capacity during majority of ice-making process**

- ◆ Average fluid temperature entering tank
- ◆ Typical entering condenser-water temperature (for water-cooled chillers)
- ◆ Typical ambient dry-bulb temperature (for air-cooled chillers)

Figure 50

As mentioned in Period Two (Figure 15 on page 12), the temperature of the fluid entering the ice storage tank must decrease near the end of the freezing process in order to maintain the same freeze rate. For this reason, the chiller needs to be selected for ice-making duty during the majority of the ice-making process, and then checked to verify that it will operate stably at the more extreme conditions.

It is very important to not oversize chiller capacity when making ice. While this is a common practice in conventional chilled-water systems to allow for future growth, oversizing the capacity of the chiller in ice-making mode will upset the balance between chiller capacity and tank freeze rate, and can lead to system control problems.

To avoid oversizing, the first step is to determine the capacity and efficiency of the chiller during the majority of ice-making mode, balancing it with the freeze rate of the ice storage tank. The selection should be based on the average fluid temperature entering the tank, as provided by the ice storage tank manufacturer, and the actual condensing conditions that are expected to occur when the chiller is operating in ice-making mode.

For a water-cooled chiller, this selection should be based on the entering condenser-water temperature that is available from the cooling tower at the time when the chiller is operating in ice-making mode (usually during the night). As shown in Figure 21 on page 16, the wet-bulb temperature during the night is typically several degrees lower than during daytime hours. This usually allows a cooling tower to deliver colder water to the condenser of a water-cooled chiller.

For an air-cooled chiller, this selection should be based on the dry-bulb temperature of the ambient air at this time (again, usually during the night). The outdoor dry-bulb temperature is also usually cooler at night than during the day. This allows an air-cooled chiller to operating at a lower refrigerant condensing pressure.

Do not assume extreme condensing conditions for this selection. Doing so will result in oversizing the chiller capacity for ice-making duty.

## period three

# Design Process

### notes

#### selecting the ice-making chiller **Ice-Making Mode**

##### ▲ **Verify stability at end of ice-making process**

- ◆ Final fluid temperature entering tank
- ◆ Extreme entering condenser-water temperature (for water-cooled chillers)
- ◆ Extreme ambient dry-bulb temperature (for air-cooled chillers)

Figure 51

The next step is to verify stable operation of the chiller at extreme conditions that may exist during the ice-making process.

First, verify that the chiller will be able to operate reliably near the end of the ice-making process, when it produces colder fluid temperatures. The final fluid temperature entering the tank, which is typically a few degrees colder than the average temperature, is typically provided by the ice storage tank manufacturer for the specific application.

Second, verify that the chiller will be able to operate reliably under extreme (or design) condensing conditions. Typically, the average fluid temperature entering the tank is used when checking operation at these conditions. Consult the chiller manufacturer for specific guidance.

Again, the purpose of this step is to verify that the ice-making chiller can operate stably at these extreme conditions. The fact that the chiller capacity is reduced under these conditions, however, is normal and has little impact on the success of the ice storage system.



## period three

# Design Process

## notes

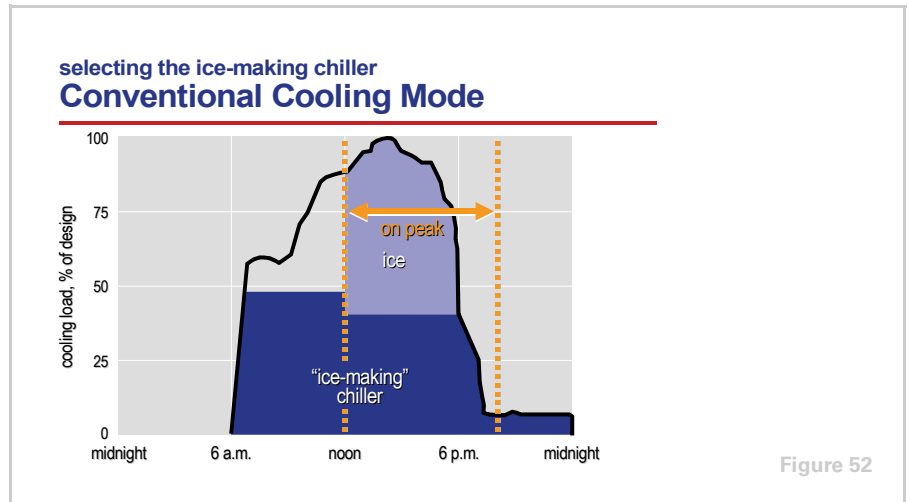

After verifying the performance of the selected chiller in ice-making mode, the next task is to consider the operation of the chiller during conventional cooling mode.

In the example design-day cooling-load profile shown in Figure 52, melting the stored ice in this partial-storage system satisfies a portion of the on-peak cooling requirement. However, there is a substantial portion of the daily cooling requirement that remains to be satisfied. Additional cooling capacity is required.

One option is to operate the ice-making chiller in conventional cooling mode to satisfy some, or all, of the remaining cooling loads. After the ice-making chiller has been selected for ice-making duty, the same chiller selection software is used to determine the cooling capacity of the chiller when operating in conventional cooling mode.

For some installations, additional chiller capacity or storage capacity may be required. For the example in Figure 52, the melt rate of the ice storage tanks, combined with the cooling capacity of the ice-making chiller, provides enough cooling capacity to satisfy the on-peak cooling loads. The ice-making chiller, however, is unable to provide enough cooling capacity to satisfy the remaining cooling loads on the design day.

## period three

# Design Process

---

### notes

#### Additional Daytime Cooling Capacity

- ▲ Increase size of ice-making chiller and add more ice storage capacity
- ▲ Use existing, unused chiller capacity
- ▲ Add another chiller
  - ◆ “Load-balancing” chiller
  - ◆ “Baseline” chiller

Figure 53

If the shortfall in capacity is very small, it may be tempting to upsize the ice-making chiller. Increasing the conventional cooling capacity of the ice-making chiller, however, will also increase its capacity during the ice-making mode. This may require the addition of storage capacity to re-balance the freeze rate with the ice-making capacity of the chiller.

On the other hand, if there are other chillers already installed in the building, they may have additional, unused capacity that could be used to satisfy the remaining cooling load.

Finally, meeting the required daytime cooling loads can also be accomplished by adding another chiller to the system. This additional chiller may be selected as either a “load balancing” chiller or as a “baseline” chiller.

## period three

# Design Process

### notes

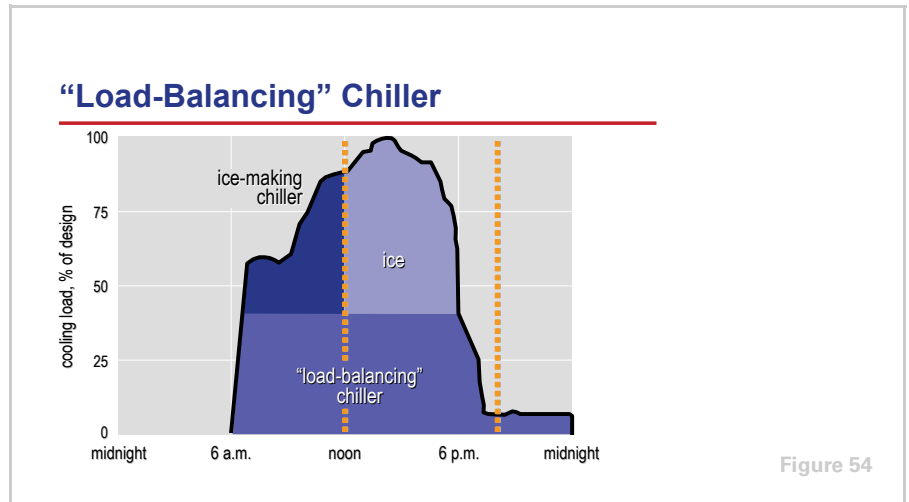

A “load-balancing” chiller is a conventional, cooling-only chiller that has just enough capacity to meet the portion of the cooling load that is not satisfied by melting ice or operating the ice-making chiller.

This approach meets the design-day cooling loads at a minimal installed cost. However, there is little redundancy and minimal standby capacity. In an emergency, cooling may need to be provided by rental chillers.

When the “load-balancing” chiller uses a positive-displacement compressor (scroll, helical-rotary, reciprocating), it can also be used as a backup ice-making chiller. It does not necessarily need to be the same capacity as the ice-making chiller. A smaller “load-balancing” chiller can back up a larger ice-making chiller, but less ice will be produced if it needs to operate in this mode.

The use of a “load-balancing” chiller is most common in smaller ice storage systems that include multiple chillers with positive-displacement compressors.

## period three

# Design Process

## notes

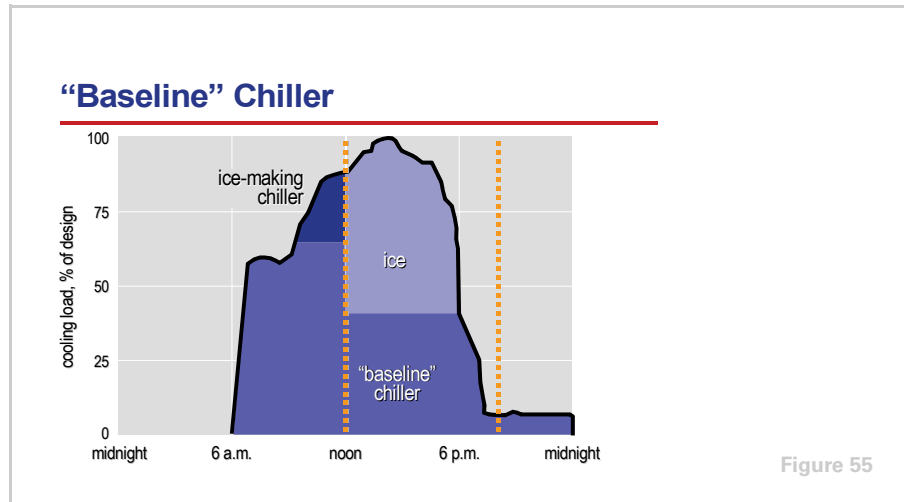

A “baseline” chiller is a conventional, cooling-only chiller that is used to satisfy a larger portion (or all) of the daily and annual cooling loads than a “load balancing” chiller. It is typically selected to be more efficient than the ice-making chiller operating in cooling mode.

The larger capacity of a “baseline” chiller allows for some redundancy and provides additional capacity for future growth. The ice-making chiller, while it may be used as a backup for the “baseline” chiller, typically operates infrequently in conventional cooling mode.

As mentioned earlier, centrifugal chillers selected for ice-making duty require higher-than-normal impeller tip speed. This often results in less-than-optimal efficiency when operating in conventional cooling mode. A “baseline” centrifugal chiller can be optimized for cooling mode (selected with a lower impeller tip speed), allowing it to be more efficient than an ice-making centrifugal chiller.

The use of a “baseline” chiller is most common in larger ice storage systems that include multiple chillers, whereas the ice-making chiller uses a centrifugal compressor.

## period four

# System Layout

## notes

### Ice Storage Systems

*period four*  
System Layout

Figure 56

Period Four discusses the typical layout, or configuration, of the equipment used in both a small and a large ice storage system.

### Small Air-Cooled System

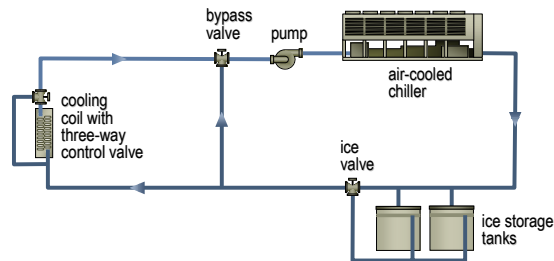

Figure 57

Most ice storage systems are used in smaller buildings. In these smaller systems, the equipment layout is similar to that shown in Figure 57. This popular system configuration requires a single constant-volume pump to circulate the heat-transfer fluid through the chiller, ice storage tanks, and cooling coils. Because this is a constant-flow system, the capacity of the cooling coil is modulated with a three-way control valve. (For clarity, only a single cooling coil is shown.)

The ice storage tanks are configured in *series* with the chiller, and are located *downstream* of the chiller. This series configuration allows the system to achieve a large coil  $\Delta T$ , which results in a lower fluid flow rate and reduces pumping energy.

## period four

# System Layout

### notes

Locating the tanks downstream of the chiller allows the control system to preferentially load the chiller, that is, give the chiller the first chance to satisfy the cooling load. If the chiller is unable to satisfy the load, either because it is operating at maximum capacity or because the control system is limiting chiller capacity, the ice storage tanks satisfy the remaining load. Also, placing the chiller upstream allows it to make a warmer leaving-fluid temperature when it operates simultaneously with the tanks. This increases the capacity and efficiency of the chiller.

This system configuration is successful because it is simple to design and the controls are straightforward. Both the chiller and ice storage tanks are controlled to maintain the desired fluid temperature sent to the cooling coils. Any load not satisfied by the chiller will be satisfied by the ice storage tanks. System controls will be discussed further in Period Five.

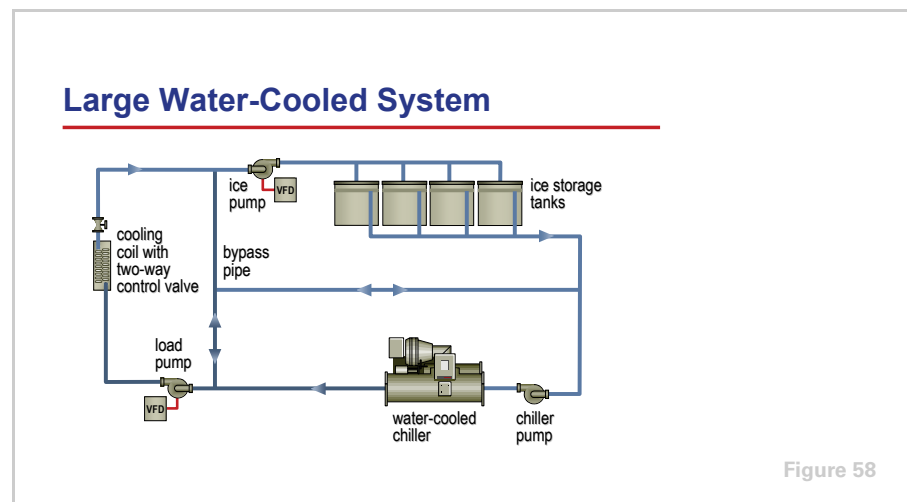

As an ice storage system gets larger, the opportunity to optimize pump power is often justified. This is accomplished by using three separate pumps, each with its own specialized duty. In the example, larger system shown in Figure 58, the constant-volume **chiller pump** is sized to deliver the design system flow rate, but with only as much head as required to overcome the pressure drop of the chiller evaporator.

The variable-volume **load pump** is sized to deliver the design system flow rate, with enough head to overcome the pressure drop of the cooling coils, control valves, and piping that make up the distribution system. Because this is a variable-flow system, the capacity of the cooling coil is modulated with a two-way control valve. As the building cooling load decreases, the load pump responds by decreasing the quantity of fluid circulated, thereby reducing the energy used by the load pump.

The variable-volume **ice pump** is sized to deliver the design system flow rate, but with only as much head as required to overcome the pressure drop of the ice storage tanks. The ice pump varies the quantity of fluid circulated through the tanks to vary the portion of the cooling load satisfied by melting ice.

## period four

# System Layout

### notes

This example uses a primary-secondary (or decoupled) pumping arrangement with a unique multipurpose bypass pipe. This bypass pipe has three ends that allow it to decouple the chiller from the load (cooling coils), and to decouple the chiller from the ice storage tanks. Thus, this bypass pipe allows balanced flow at all times, even when the respective flow rates of the ice pump, load pump, and chiller pump are unequal. Again, control of this system will be discussed further in Period Five.

This system configuration is very flexible, allows the use of several control strategies, and optimizes pumping energy. Similar to the small-system example shown previously, the ice storage tanks in this large system are also configured in *series* with the chiller. Unlike the small system, however, the tanks are located *upstream* of the chiller, which increases storage capacity and reduces the installed cost of the system.

#### ice tanks in series with chiller Downstream or Upstream?

##### Example:

- ▲ "On peak" cooling required = 8,500 ton-hr  
(29,895 kWh)
- ▲ Length of "on peak" period = 12 hours
- ▲ System flow rate = 1,200 gpm  
(75.7 L/s)
- ▲ Cooling coil  $\Delta T$  = 20°F  
(11.1°C)
- ▲ Fluid = 25% ethylene glycol
- ▲ Available space = 20 ice storage tanks

Figure 59

Should the ice storage tanks be located upstream or downstream of the chiller?

Both the chiller and the ice storage tanks benefit from being located upstream, where they get the warmest-temperature fluid that returns from the cooling coils. To the chiller, this warmer fluid temperature results in increased capacity and improved efficiency. To the ice storage tanks, this warmer fluid temperature results in increased storage capacity, which can reduce the number, or size, of tanks required.

For example, a building has a design-day, on-peak cooling requirement of 8,500 ton-hours (29,895 kWh). The system flow rate is 1,200 gpm (75.7 L/s) and the cooling coils are selected for a 20°F (11.1°C)  $\Delta T$ . However, there is limited space available—only enough to install 20 ice storage tanks.

## period four

# System Layout

## notes

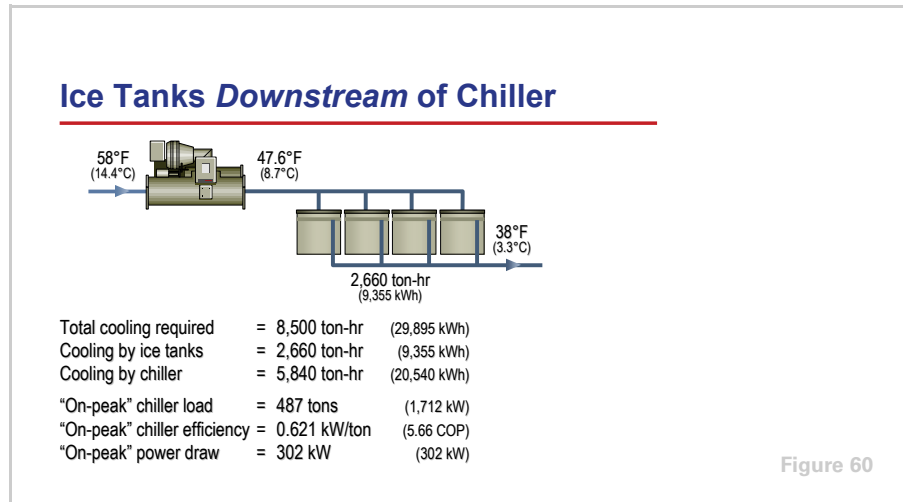

First, consider if the ice storage tanks are located *downstream* of the chiller. This configuration allows the chiller to receive the warmest, entering-fluid temperature, and to produce a higher leaving-fluid temperature. This results in increased chiller capacity and improved efficiency. In this example, the chiller cools the fluid from 58°F (14.4°C) to 47.6°F (8.7°C), at an efficiency of 0.621 kW/ton (5.66 COP).

The downstream ice storage tanks cool the fluid from 47.6°F (8.7°C) to 38°F (3.3°C). At these temperatures, the 20 ice storage tanks in this example can provide 2,660 ton-hours (9,355 kWh) of cooling, leaving an on-peak cooling requirement of 5,840 ton-hours (20,540 kWh) that must be satisfied by the chiller.

If we assume the chiller operates at a constant capacity for the 12-hour on-peak period, the hourly cooling load that must be satisfied by the chiller is 487 tons (1,712 kW). Operating at 0.621 kW/ton (5.66 COP), this results in an on-peak power draw of 302 kW.



## period four

# System Layout

## notes

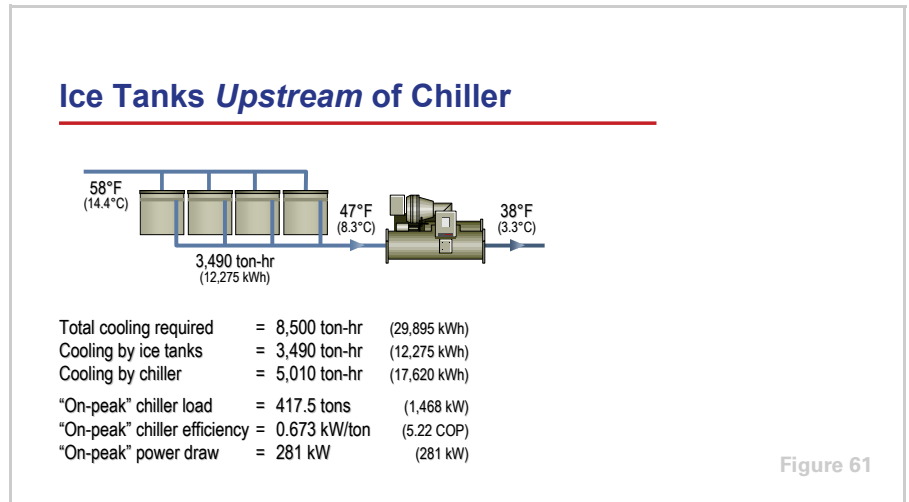

Now, consider if the ice storage tanks are located *upstream* of the chiller, instead of downstream. This configuration allows the tanks to receive the warmest entering-fluid temperature and operate at a higher leaving-fluid temperature. This results in increased storage capacity.

Using this same example, the upstream storage tanks cool the fluid from 58°F (14.4°C) to 47°F (8.3°C). At these warmer temperatures, the 20 ice storage tanks can provide 3,490 ton-hours (12,275 kWh) of cooling—31 percent more capacity than when these same tanks were located downstream of the chiller. This reduces the on-peak cooling requirement that must be satisfied by the chiller to 5,010 ton-hours (17,620 kWh). Again, if we assume the chiller operates at a constant capacity for the 12-hour on-peak period, the hourly cooling load that must be satisfied by the chiller is 417.5 tons (1,468 kW).

With the chiller located downstream, however, it must cool the fluid from 47°F (8.3°C) to 38°F (3.3°C). These colder fluid temperatures degrade the efficiency of the chiller to 0.673 kW/ton (5.22 COP).

Because this configuration reduces the on-peak cooling load that must be satisfied by the chiller, however, even operating less efficiently, the on-peak power draw of the chiller is reduced to 281 kW—7 percent lower than when the tanks were located downstream.

Of course, many ice storage systems contain cooling-only chillers in addition to the ice-making chiller(s). When centrifugal chillers are used, these cooling-only centrifugal chillers can be selected for higher efficiencies than the ice-making centrifugal chiller operating in conventional cooling mode. This will result in even greater on-peak demand reduction.

## period four

# System Layout

### notes

#### ice tanks in series with chiller Downstream or Upstream?

tank location	downstream of chiller	upstream of chiller
ice tank capacity	2,660 ton-hr (9,355 kWh)	<b>3,490 ton-hr</b> <b>(12,275 kWh)</b>
"on-peak" power draw	302 kW	<b>281 kW</b>

Figure 62

Locating the 20 ice storage tanks upstream of the chiller, rather than downstream, reduced the on-peak electrical demand by an additional 21 kW.

If the mission of this example ice storage system is to reduce on-peak electrical demand, the upstream location maximized storage capacity of the fixed number of tanks and resulted in a lower "on-peak" power draw.

#### ice tanks in series with chiller Downstream or Upstream?

tank location	downstream of chiller	upstream of chiller
ice tank capacity	2,660 ton-hr (9,355 kWh)	2,660 ton-hr (9,355 kWh)
number of tanks	20	<b>16</b>

Figure 63

What if the mission of this system is to reduce on-peak electrical consumption, for an attractive financial return?

Assume the economic analysis has determined that the optimal storage capacity is 2,600 ton-hours (9,355 kWh). In this case, using this same example system, the desired storage capacity could be obtained either by installing 20 ice storage tanks *downstream* of the chiller, or by installing only 16 tanks *upstream* of the chiller.

## period four

# System Layout

### notes

Locating the tanks upstream achieves the desired storage capacity with fewer tanks. This reduces the installed cost of the system and reduces the space required for the storage tanks.

#### ice tanks in series with chiller **Downstream or Upstream?**

- ▲ **When using chillers with helical-rotary or scroll compressors ...**
  - ◆ Locate tanks downstream of chillers
- ▲ **When using chillers with centrifugal compressors ...**
  - ◆ Locate tanks upstream of chillers

Figure 64

When the system contains only a few tanks, the increased storage capacity of locating the tanks upstream might only eliminate the need for one tank, and possibly not have any impact on the number of tanks installed. However, the increase in capacity and efficiency that results from locating the chiller upstream is more pronounced in a chiller that uses a positive-displacement (helical-rotary, scroll, or reciprocating) compressor—which is typically used in small ice storage systems—than it is in a chiller that uses a centrifugal compressor.

When the ice storage system contains a large number of tanks, locating the tanks upstream has a more significant impact on the number of tanks required and, therefore, the installed cost of the system. In addition, large ice storage systems typically use chillers with centrifugal compressors. The impact of colder fluid temperatures on the capacity and efficiency of a centrifugal chiller is not as pronounced as in a chiller that uses a positive-displacement compressor.

Therefore, in small systems that use helical-rotary or scroll chillers, locate the tanks downstream of the chillers. But, in large systems that use centrifugal chillers, locate the tanks upstream.

## period four

# System Layout

### notes

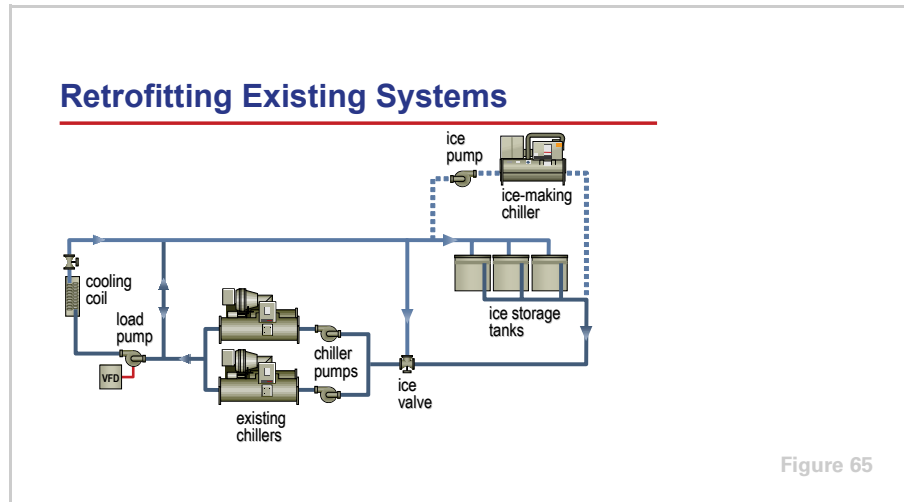

What about adding ice storage to an existing system? Many existing chillers are not capable of producing the lower fluid temperatures required for ice-making mode. Furthermore, existing centrifugal chillers were likely selected for conventional cooling operation, and retrofitting these chillers for operation in ice-making mode would result in a significant loss of efficiency when the chiller operates in conventional cooling mode. Consequently, in most retrofit situations, the system is expanded by selecting one or more new chillers, optimized for ice-making duty.

As shown in Figure 65, the ice storage tanks are located in series with, and upstream of, the existing cooling-only chillers. This maximizes the storage capacity of the tanks, and leaves the existing chillers operating at the same conditions as before. When melting ice is desired, the ice valve diverts some of the heat-transfer fluid returning from the cooling coils through the ice storage tanks. The cold fluid leaving the tanks mixes with the rest of the warm return water, lowering the temperature of the fluid entering the cooling-only chillers. This allows the chillers to operate at reduced capacity and reduced energy use.

## period four

# System Layout

## notes

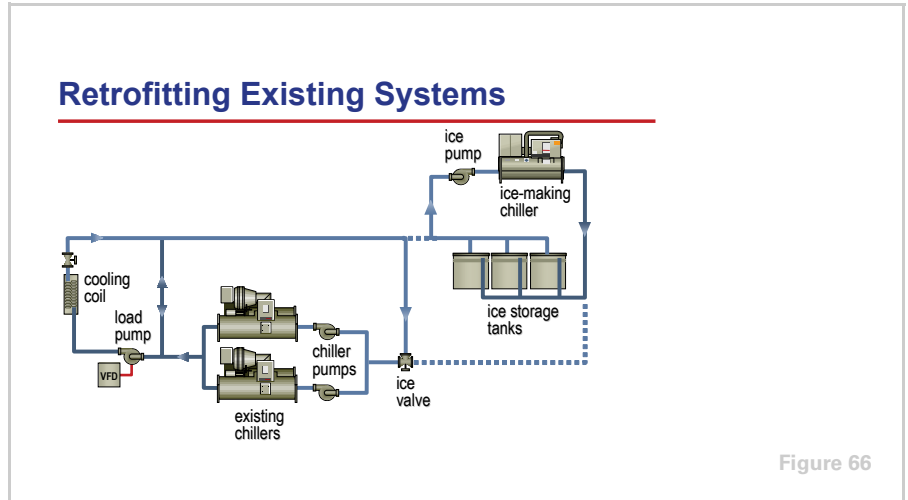

During the off-peak period, the ice valve diverts all the fluid returning from the cooling coils to bypass the tanks, isolating the tanks and ice-making chiller in a separate loop. The ice pump circulates the heat-transfer fluid through the ice-making chiller and storage tanks, freezing the water inside the tanks.

Of course, this system now requires antifreeze to be added to the heat-transfer fluid and pumped throughout the entire system.

## period four

# System Layout

## notes

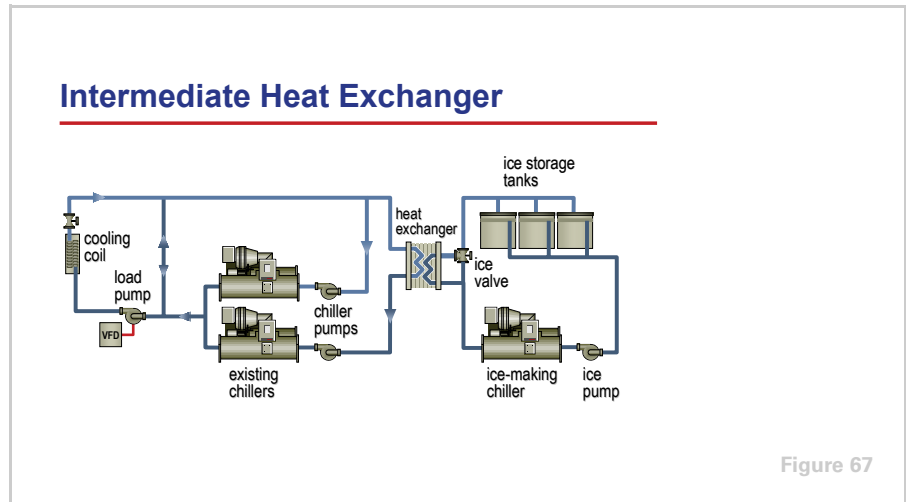

In some existing systems, it may be desirable to avoid the burden of pumping this antifreeze-and-water solution throughout the entire system. An alternative approach is to install a heat exchanger between the existing chilled-water system and the new ice storage system. Now, the antifreeze-and-water solution need only be circulated through the new system components. This approach has the added benefit of shielding the ice storage tanks from higher head pressures that may be generated by the existing pumping system.

Notice that the heat exchanger is located in series with one of the existing chillers, but in parallel with the other. This allows the heat exchanger to be sized for only the portion of the cooling load that is to be satisfied by melting ice, not for the entire load. This reduces the installed cost of this heat exchanger.

## period five

# System Control

---

### notes

### Ice Storage Systems

*period five*  
System Control

Figure 68

Period Five discusses the control of the small and large ice storage systems that were introduced in Period Four.

### System Control

**“Tactical” control = How?**

**“Strategic” control = When?**

Figure 69

The task of developing a control sequence for an ice storage system can be simplified by dividing control into two categories, tactical and strategic.

Tactical control defines *how* to perform a certain function. For example, knowing how to fill the gas tank of a car. Strategic control, however, defines *when* to perform that function. For example, knowing when to fill the gas tank.

Neither tactical nor strategic control can do the job by itself. Knowing that the gas tank is empty and finding a gas station at the next exit is of little value if one does not know how to put the gasoline into the tank.

## period five

# System Control

### notes

#### Tactical Control Table

function	component 1	component 2	component 3
operating mode 1	action	action	action
operating mode 2	action	action	action
operating mode 3	action	action	action



Figure 70

#### Tactical Control

The first half of Period Five discusses tactical control of an ice storage system. The construction of a table like the one shown in Figure 70 can help identify all the necessary actions required to perform a certain function.

Listed under the column titled “function” will be the various operating modes for the ice storage system. The remaining columns will be used to define the actions of the individual system components (pumps, valves, chillers, and so on). This table is used to describe the action each component must take during each of the system operating modes. As the arrows indicate, this table can be extended for more modes of operation or additional components.

#### System Operating Modes

1. Provide cooling with chiller only
2. Provide cooling with ice only
3. Provide cooling with chiller and ice
4. Freeze ice storage tanks
5. Freeze tanks and provide cooling
6. System off

Figure 71

The first step is to define the operating modes for the ice storage system. For this discussion, we will consider six operating modes:



## period five

# System Control

---

### notes

#### 1. Provide cooling with the chiller only (“chiller only”)

There are typically several hours during the day, and several days during the year, when the electricity rates are low enough that operating the chiller alone is the most economical means of satisfying the cooling load. In this operating mode, the system must be able to satisfy the cooling load without melting any of the stored ice.

#### 2. Provide cooling with the ice only (“ice only”)

The greatest reduction in electrical demand occurs when the cooling load is satisfied solely by melting the stored ice, while the chiller is turned off. When the on-peak electrical consumption (kWh) or demand (kW) rates are high, this may be the most economical means of satisfying the cooling load. In this operating mode, the system must be able to satisfy the entire cooling load by melting the stored ice, without needing to operate the chiller.

#### 3. Provide cooling with the chiller and ice (“chiller and ice”)

In some cases, there may be hours during the day when the cooling load exceeds either the capacity of the chiller or the melt rate of the ice storage tanks. Both must therefore be used simultaneously to satisfy the load. In this operating mode, the system must be able to satisfy the cooling load both by using the chiller and by melting the stored ice.

#### 4. Freeze ice storage tanks (“freeze”)

When electricity rates are low, the chiller operates in ice-making mode to freeze the water inside the ice storage tanks. In this operating mode, the chiller produces low-temperature fluid that is circulated through the tanks, freezing the water stored inside the tanks.

#### 5. Freeze tanks and provide cooling (“freeze and cool”)

Sometimes, it may be necessary to freeze the water inside the tanks while a cooling load from the building still exists. In this operating mode, the system must be able to satisfy the building cooling load at the same time that it freezes the water stored inside the tanks.

#### 6. System off (“off”)

When all the water inside the tanks is frozen, and there is no building cooling load, the chiller and pumps can be turned off to conserve energy.

## period five

# System Control

---

### notes

#### Tactical Control Table

---

function	component 1	component 2	component 3	component 4
chiller only				
ice only				
chiller and ice				
freeze				
freeze and cool				
off				

Figure 72

With the operating modes defined, the next step is to identify the individual system components (pumps, valves, chillers, and so on) that will be part of the control sequence.

# period five

## System Control

### notes

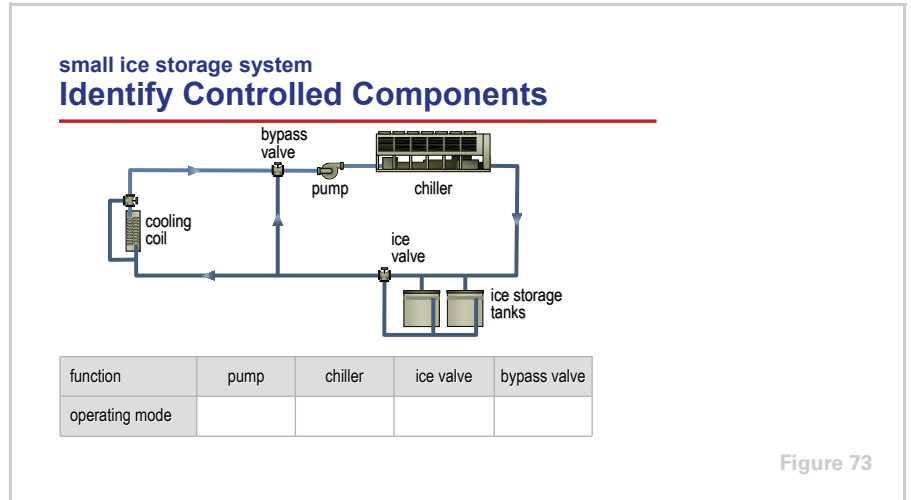

Figure 73 displays the example small ice storage system introduced in Period Four. The ice storage tanks are configured in series with, and located downstream of, the chiller.

This system uses a single constant-volume pump to circulate the heat-transfer fluid through the chiller, ice storage tanks, and cooling coils. The chiller includes a controller that allows it to operate in conventional cooling mode as well as in ice-making mode.

The rate at which the ice is melted can be varied using a three-way modulating ice valve that blends the cold fluid leaving the tanks with the warmer fluid that bypasses the tanks.

A two-position bypass valve allows the fluid leaving the tanks either to be delivered to the cooling coils or to return directly to the chiller.

The controlled components for this small ice storage system are: the pump, the chiller, the ice valve, and the bypass valve. With the column headings of the table filled in, the final step is to identify the action required of each controlled component during each of the system operating modes.

## period five

# System Control

### notes

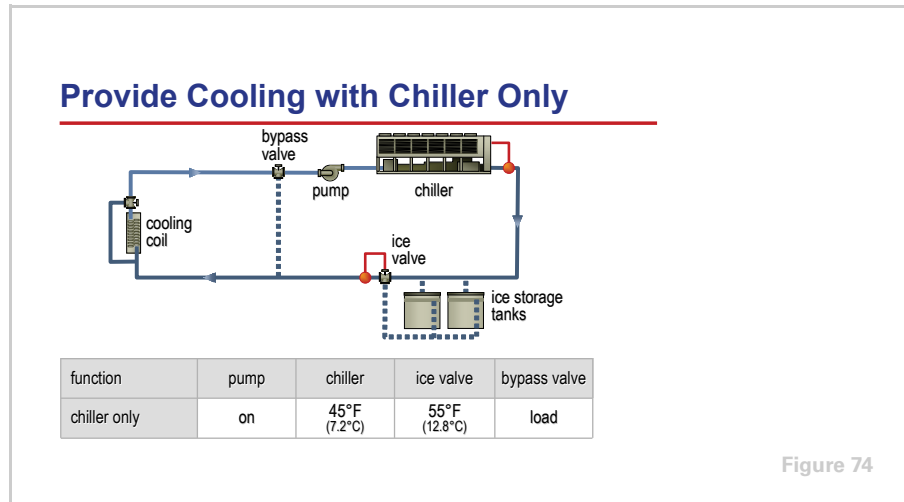

Figure 74

The first operating mode is to provide cooling by using the chiller alone.

This requires the pump to be turned on, circulating the heat-transfer fluid throughout the system. In order to offset the cooling load, the chiller must also be operating and delivering the desired system supply temperature. For this example, that setpoint is 45°F (7.2°C).

The ice valve is a blending valve that mixes cold fluid from the tanks with warmer fluid that bypasses the tanks, to achieve the desired temperature downstream of the valve. If the fluid temperature downstream of the ice valve is lower than the ice valve setpoint, this blending valve decreases the flow of colder fluid coming from the storage tanks and increases the flow of warmer fluid bypassing the tanks, thereby raising the downstream temperature.

In this operating mode, the setpoint for the ice valve is raised to 55°F (12.8°C). Because the chiller provides 45°F (7.2°C) fluid, which is colder than the valve setpoint, the ice valve adjusts so that no fluid passes through the ice storage tanks. This avoids melting ice during this operating mode.

Finally, the bypass valve is positioned to direct the cold heat-transfer fluid out to the cooling coils (the "load").

## period five

# System Control

### notes

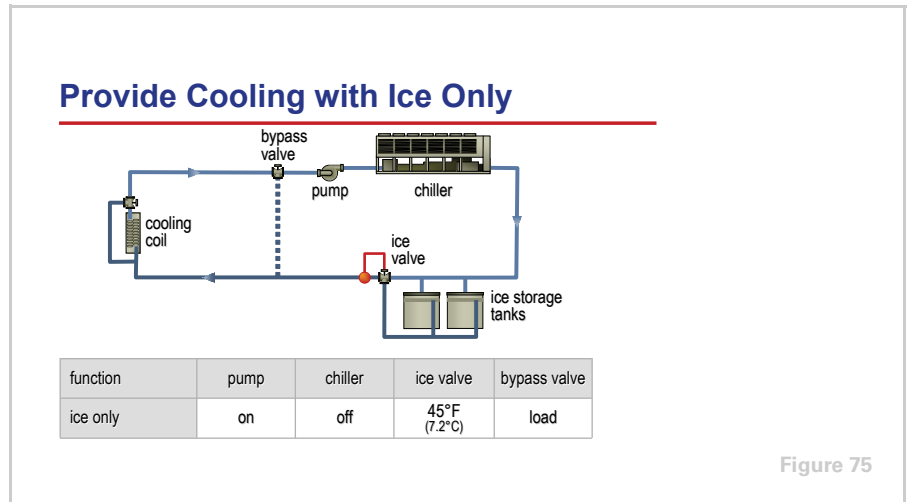

The second operating mode is to provide cooling by melting the ice alone.

Again, the pump is turned on to circulate the heat-transfer fluid. The chiller, however, is turned off because the ice storage tanks are to be the sole providers of cooling.

The setpoint for the ice valve is adjusted to 45°F (7.2°C), which is the desired system supply temperature. Because the chiller is turned off, the temperature of the fluid bypassing the tanks is warmer than the valve setpoint. Therefore, the ice valve mixes cold fluid coming from the ice storage tanks with this warmer fluid bypassing the tanks to achieve the desired 45°F (7.2°C) fluid temperature downstream of the ice valve.

Finally, the bypass valve is positioned to direct the cold fluid out to the cooling coils.

## period five

# System Control

### notes

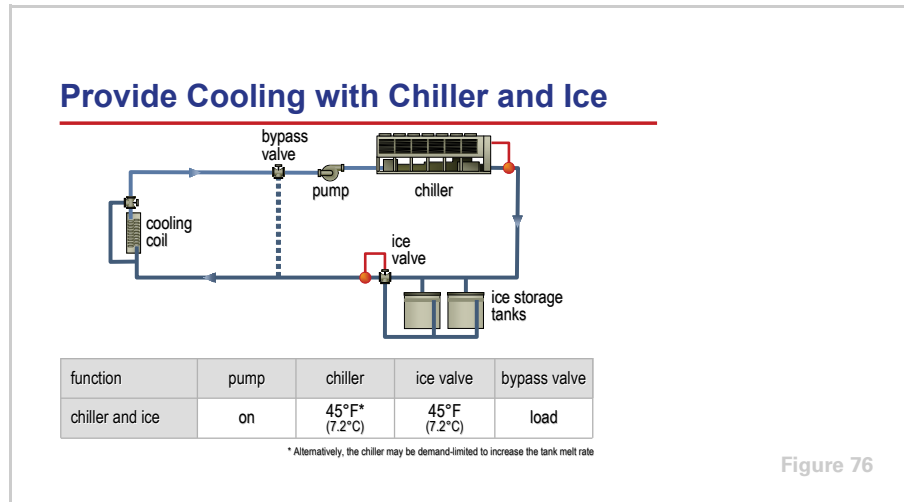

Figure 76

The third operating mode is to provide cooling by operating the chiller and melting the ice simultaneously.

Again, the pump is turned on, and the bypass valve is positioned to direct the cold fluid out to the cooling coils.

This chiller is turned on and its setpoint is adjusted to 45°F (7.2°C). The setpoint for the ice valve is also adjusted to 45°F (7.2°C). In this operating mode, both the chiller and the ice storage tanks work together to produce the desired system supply temperature.

Because the chiller is in series with, and positioned upstream of, the ice storage tanks, the chiller will be preferentially loaded. This means the chiller is given the first opportunity to satisfy the cooling load. If the chiller has sufficient capacity to cool the fluid to the 45°F (7.2°C) setpoint, the setpoint of the ice valve will be satisfied and no fluid will flow through the ice storage tanks.

However, if the chiller does not have enough capacity, and is only able to cool the fluid to 50°F (10°C), for example, the ice storage tanks will satisfy the remainder of the cooling load. The ice valve will mix cold fluid coming from the ice storage tanks with this 50°F (10°C) fluid from the chiller to achieve the desired 45°F (7.2°C) fluid temperature downstream of the ice valve.

The control system can be used to adjust the portion of the cooling load that is satisfied by the chiller and, therefore, the rate at which the ice melts. Limiting the capacity of the chiller, either through demand limiting or by raising the chiller setpoint, increases the portion of the cooling load that is satisfied by melting ice.

## period five

# System Control

### notes

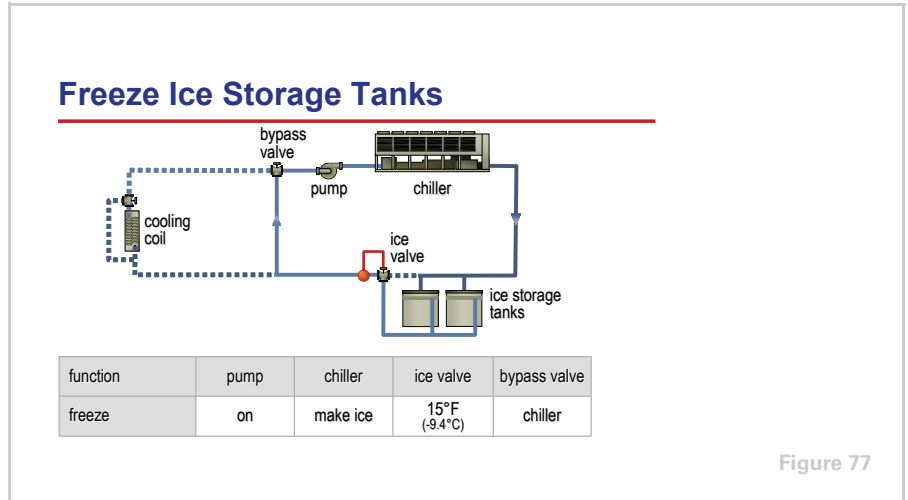

The fourth operating mode is to freeze the water inside the ice storage tanks.

The pump is turned on to circulate the heat-transfer fluid. In this operating mode, because there is no building cooling load, the bypass valve is positioned to direct the cold fluid back to the chiller, bypassing the cooling coils.

The chiller is switched to operate in ice-making mode. In this mode, the chiller operates at full cooling capacity, lowering its leaving-fluid temperature to somewhere between 20°F and 25°F (-6.7°C and -3.9°C), cold enough to freeze the water inside the storage tanks.

In this operating mode, the setpoint for the ice valve is lowered to 15°F (-9.4°C). Because the temperature of the fluid leaving the chiller is warmer than the valve setpoint, the ice valve adjusts so that all of the fluid flows through the ice storage tanks—none is bypassed. This allows the water inside the ice storage tanks to freeze as quickly as possible.

## period five

# System Control

## notes

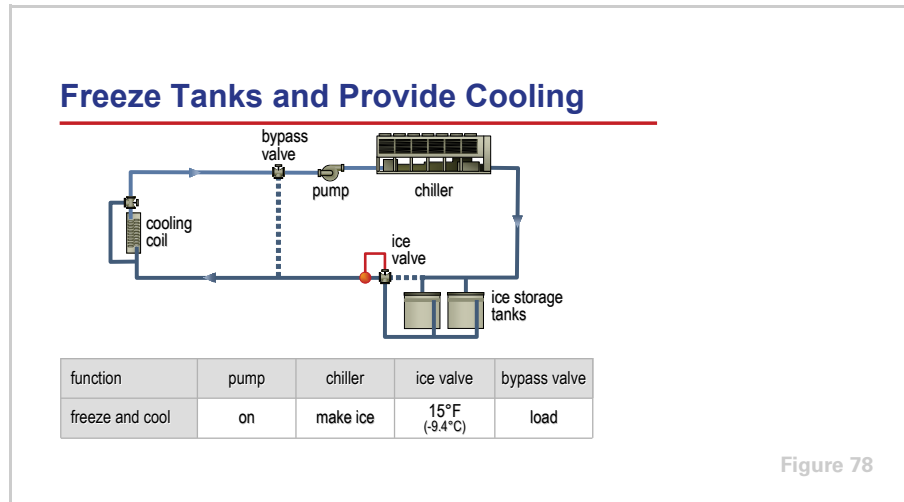

The fifth operating mode is to freeze the water inside the storage tanks and satisfy a simultaneous building cooling load.

The pump is turned on and, similar to the previous operating mode, the chiller is operating in ice-making mode and the setpoint for the ice valve is 15°F (-9.4°C). Again, this forces all of the fluid to flow through the ice storage tanks, freezing the water inside the tanks.

In this operating mode, however, because there is a simultaneous building cooling load, the bypass valve is positioned to direct the cold fluid out to the cooling coils (the “load”).

In this series configuration, the cold fluid from the chiller first passes through the ice storage tanks to freeze the water inside the tanks. Then, the fluid passes through the cooling coils to satisfy the building cooling load. In this “freeze and cool” operating mode, the fluid returns to the chiller at a warmer temperature than it would in “freeze” operating mode, because heat is transferred to the fluid inside the cooling coils. Therefore, the fluid leaves the chiller, which is still operating at full capacity, at a warmer temperature than it would if the system was in “freeze” operating mode. The result is that when the system is satisfying a simultaneous building cooling load, it takes longer to freeze the water inside the tanks.



# period five

## System Control

### notes

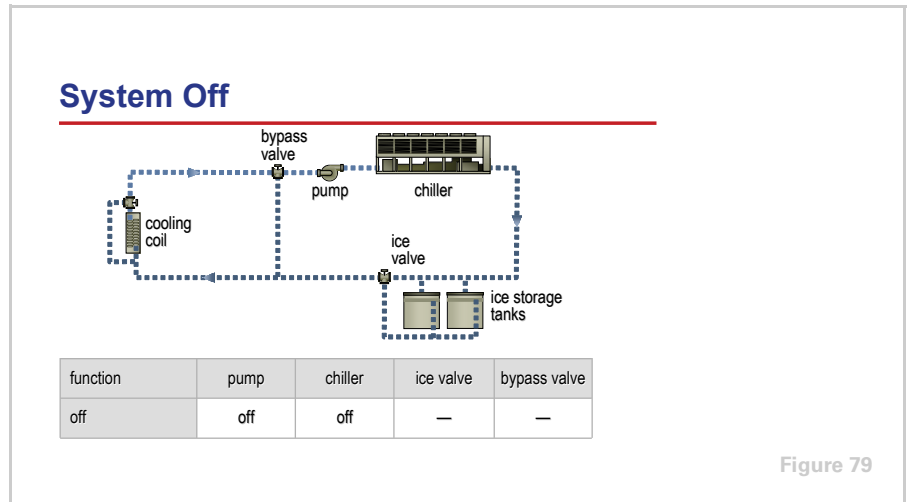

Figure 79

The final operating mode, turning the system off, is used when no building cooling load exists, and all the water inside the ice storage tanks is frozen.

Both the pump and chiller are off. Because there is no fluid flow, the positions of the ice valve and bypass valve are of no significance.

**small ice storage system**

**Completed Tactical Control Table**

function	pump	chiller	ice valve	bypass valve
chiller only	on	45°F (7.2°C)	55°F (12.8°C)	load
ice only	on	off	45°F (7.2°C)	load
chiller and ice	on	45°F (7.2°C)	45°F (7.2°C)	load
freeze	on	make ice	15°F (-9.4°C)	chiller
freeze and cool	on	make ice	15°F (-9.4°C)	load
off	off	off	—	—

Figure 80

Figure 80 shows the completed tactical control table for this example small ice storage system. It describes how to accomplish each function (operating mode) by identifying the action required of each controlled component (pump, chiller, ice valve, and bypass valve) during each of the six operating modes.

Evaluating each of these operating modes, and devising a system that operates effectively in each mode, helps ensure a reliable, simple, and adaptive ice storage system.

## period five

# System Control

### notes

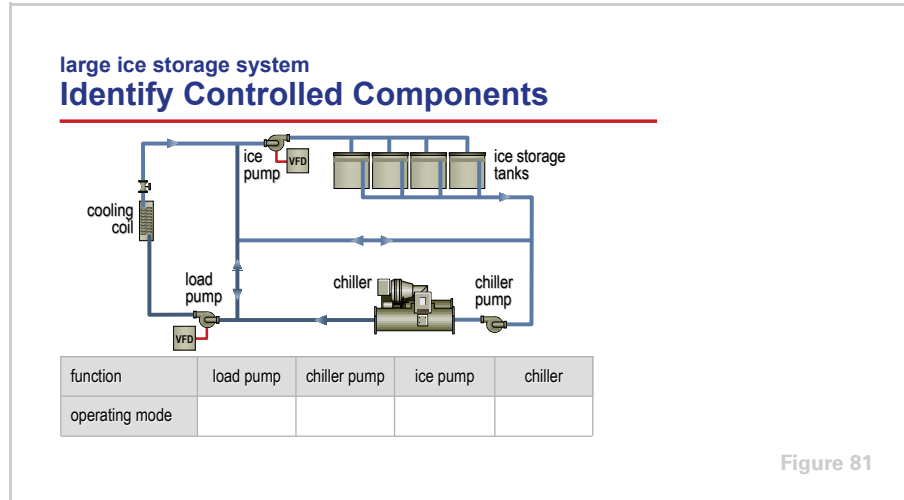

Figure 81

Figure 81 displays the example large ice storage system introduced in Period Four. The ice storage tanks are again configured in series with the chiller, but in this example, they are located upstream of the chiller.

This system uses three separate pumps, each optimized for the duty it performs. The variable-volume load pump circulates the heat-transfer fluid out to the cooling coils, varying its capacity to meet the changing building cooling load. The constant-volume chiller pump circulates the fluid through the chiller. The variable-volume ice pump circulates the fluid through the ice storage tanks, varying its capacity to adjust the portion of the cooling load that is to be satisfied by melting ice. The bypass pipe allows balanced flow at all times, even when the flow rates of these three pumps are unequal.

The controlled components for this large ice storage system are: load pump, chiller pump, ice pump, and chiller. With the column headings of the table filled in, the final step is to identify the action required of each controlled component during each of the six operating modes.

# period five

## System Control

### notes

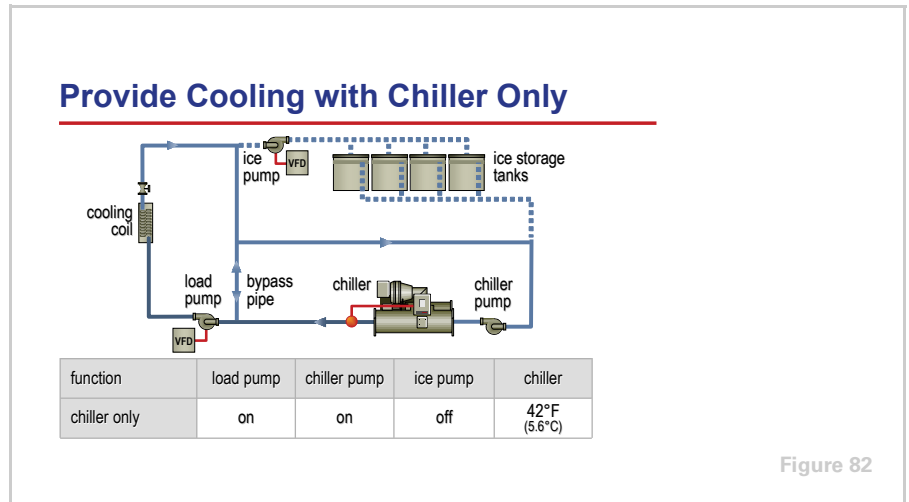

The first operating mode is to provide cooling by using the chiller alone.

This requires the load pump to be turned on, circulating the proper amount of heat-transfer fluid required to meet the flow demands of the cooling coils with two-way control valves.

In order for the chiller to offset the cooling load, both the chiller pump and the chiller must be turned on and the setpoint for the chiller adjusted to the desired system supply temperature. For this example, that setpoint is 42°F (5.6°C).

The ice pump is turned off to avoid melting ice.

In this operating mode, the bypass pipe hydraulically decouples the variable-volume load pump from the constant-volume chiller pump, and they operate as they would in a traditional primary-secondary (or decoupled) system.

## period five

# System Control

### notes

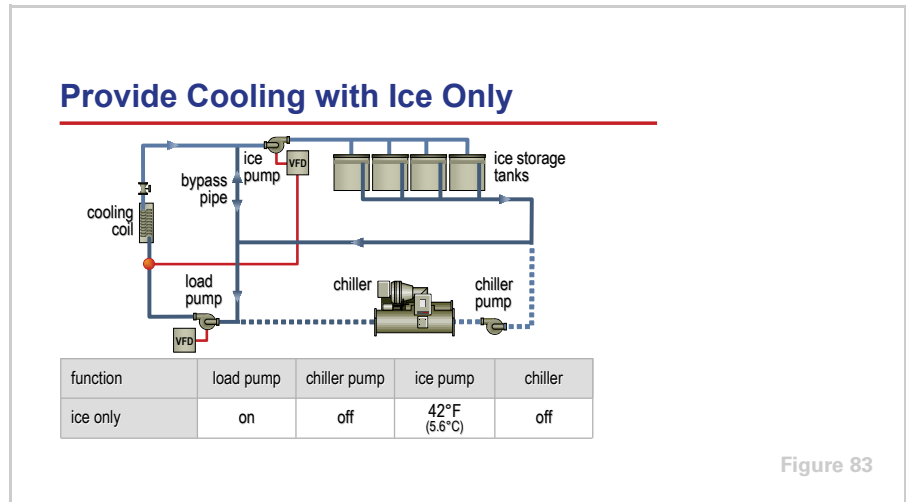

Figure 83

The second operating mode is to provide cooling by melting the ice alone.

Again, the load pump is turned on to circulate the heat-transfer fluid through the cooling coils. The chiller pump and the chiller, however, are both turned off because the ice storage tanks are to be the sole providers of cooling.

The ice pump is turned on, circulating the fluid through the ice storage tanks. The bypass pipe hydraulically decouples the variable-volume load pump from the variable-volume ice pump. The speed of the load pump is modulated to deliver the flow required to satisfy the load on the cooling coils.

The temperature of the fluid being sent out to the cooling coils is monitored by the control system. If this temperature rises above 42°F (5.6°C), which is the desired system supply temperature, the speed of the ice pump is increased, resulting in more cold fluid from the ice storage tanks being mixed with warmer fluid returning from the cooling coils. Conversely, if the temperature of the fluid being sent out to the coils drops below 42°F (5.6°C), the speed of the ice pump is decreased, resulting in less cold fluid from the tanks being mixed with warmer fluid returning from the coils.

# period five

## System Control

### notes

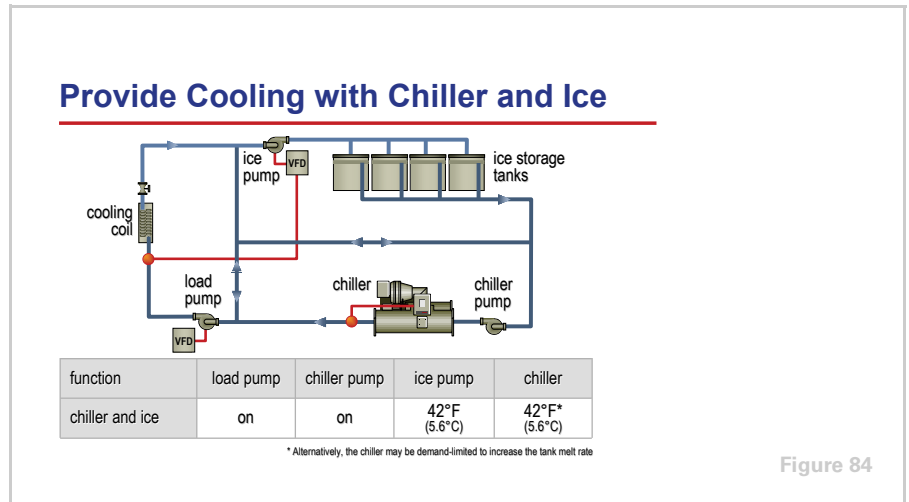

The third operating mode is to provide cooling by operating the chiller and melting ice simultaneously.

In this operating mode, all three pumps are turned on. This chiller is also turned on and its setpoint is adjusted to 42°F (5.6°C). Similar to the previous operating mode, the speed of the ice pump is controlled to maintain the system supply temperature at 42°F (5.6°C).

If the chiller has sufficient capacity to cool the fluid to the 42°F (5.6°C) setpoint, the setpoint for the ice pump will be satisfied and no fluid will flow through the tanks. However, if the chiller does not have enough capacity, and is only able to cool the fluid to 46°F (7.8°C), for example, the speed of the ice pump will increase to satisfy the remainder of the cooling load.

The control system can be used to adjust the portion of the cooling load that is satisfied by the chiller and, therefore, the rate at which the ice melts. Limiting the capacity of the chiller, either through demand limiting or raising the chiller setpoint, increases the portion of the cooling load that is satisfied by melting ice.

## period five

# System Control

### notes

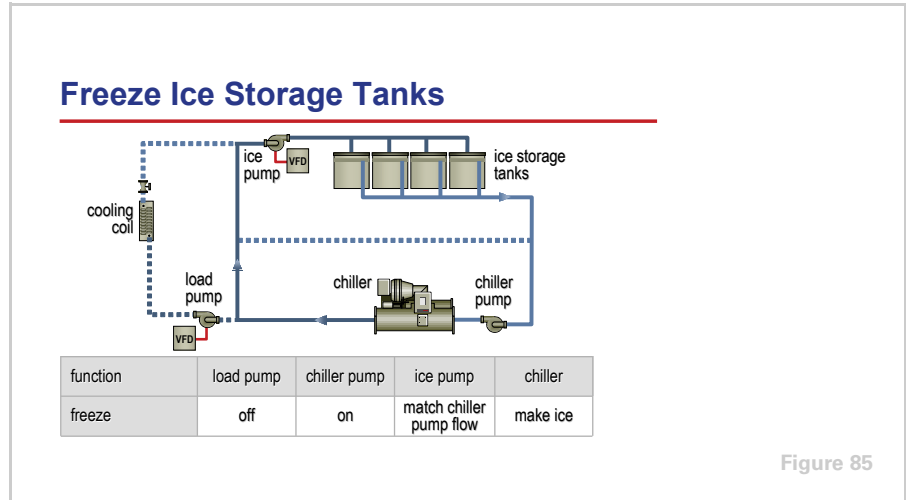

Figure 85

The fourth operating mode is to freeze the water inside the ice storage tanks.

Because there is no building cooling load, the load pump is turned off. The chiller pump is turned on and the chiller is switched to operate in ice-making mode. In this mode, the chiller operates at full cooling capacity, forcing its leaving-fluid temperature down to 20°F to 25°F (-6.7°C to -3.9°C), cold enough to freeze the water inside the storage tanks.

During this operating mode, the speed of the ice pump is controlled so that the pump flow rate (as determined during system balancing) matches the design flow rate of the constant-volume chiller pump. This allows the water inside the ice storage tanks to freeze as quickly as possible.

# period five

## System Control

### notes

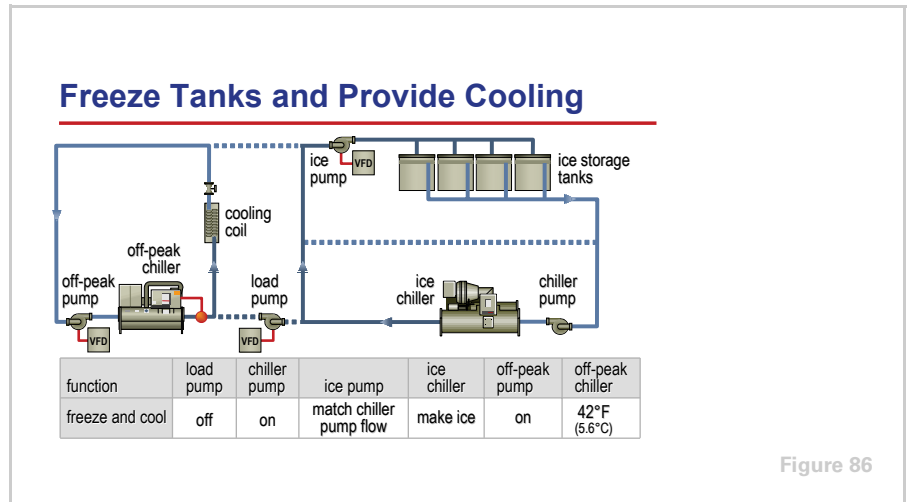

Figure 86

The fifth operating mode is to freeze the water inside the ice storage tanks and satisfy a simultaneous building cooling load.

Because large systems typically contain multiple chillers, the most-common approach is to satisfy these simultaneous loads with a separate “off-peak” (or nighttime) chiller. This allows the ice chiller to be optimized for ice-making duty and not waste energy by having to satisfy simultaneous cooling loads while operating at degraded efficiency. And, it allows the “off-peak” chiller to be sized and optimized for the largest cooling load that is expected to occur during the time period when the other chiller is making ice.

During this mode, the load pump is off, and the chiller pump, ice-making chiller, and ice pump each operate as described for “freeze” operating mode.

The off-peak pump and off-peak chiller are turned on to satisfy any simultaneous building cooling load. The setpoint for the off-peak chiller is adjusted to the desired system supply temperature. For this example, that setpoint is 42°F (5.6°C). The speed of the off-peak pump is modulated to deliver the flow required to satisfy the load on the cooling coils.

## period five

# System Control

### notes

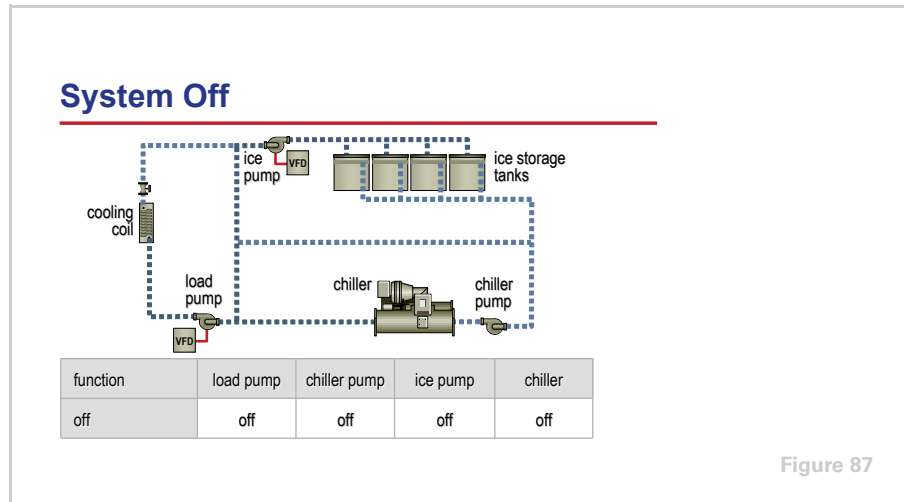

Figure 87

The final operating mode, turning the system off, is used when no building cooling load exists, and all the water inside the ice storage tanks is frozen. All three pumps and the chiller are off.

### System Control

“Tactical” control = How?

“Strategic” control = When?

Figure 88

### Strategic Control

The first half of Period Five discussed tactical control of an ice storage system, that is, *how* to perform the various functions, or operating modes.

The second half discusses the strategic control of an ice storage system, that is, *when* to initiate the various operating modes.



# period five

## System Control

### notes

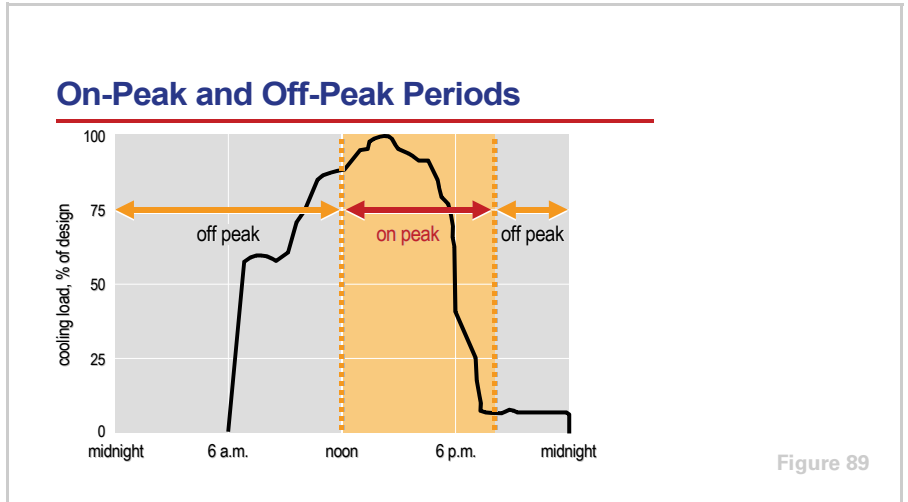

In many buildings, the thermal load is the result of building occupancy and function. Therefore, the times and days at which these loads occur are typically repetitive. Figure 89 shows the example design-day cooling-load profile introduced in Period One. The peak cooling loads for this example building occur between 11 a.m. and 4 p.m.

Noon to 8 p.m. is defined as the on-peak period, when electrical rates are highest. All other hours are defined as the off-peak period, when electrical rates are lower.



**Strategic Control Table**

operating mode	start time	end time
chiller only		
ice only		
chiller and ice		
freeze		
freeze and cool		
off		

Figure 90

After the on-peak and off-peak periods have been determined, the next step is to identify the time of day that each of the system operating modes will begin and end.

## period five

# System Control

### notes

The start time and end time for each operating mode can be compiled in a strategic control table, like the one shown in Figure 90 on page 75.

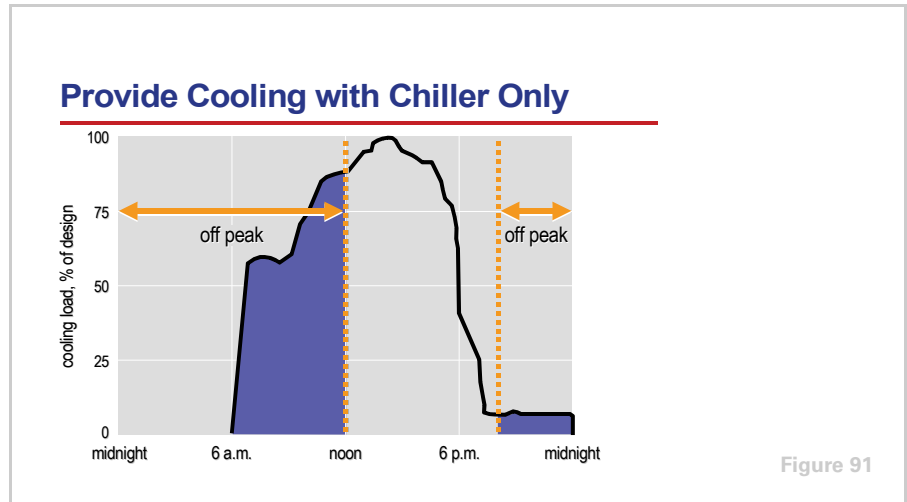

During the off-peak periods, the cost of electricity is lower and there is often no demand charge. With low-cost electricity, operating the electrically powered chiller is typically the most economical means of satisfying the building cooling load.

In this example, the building cooling loads that occur between 6 a.m. and noon, and between 8 p.m. and midnight, are satisfied by operating the chiller alone. The stored ice is not melted, but is saved for the on-peak period.

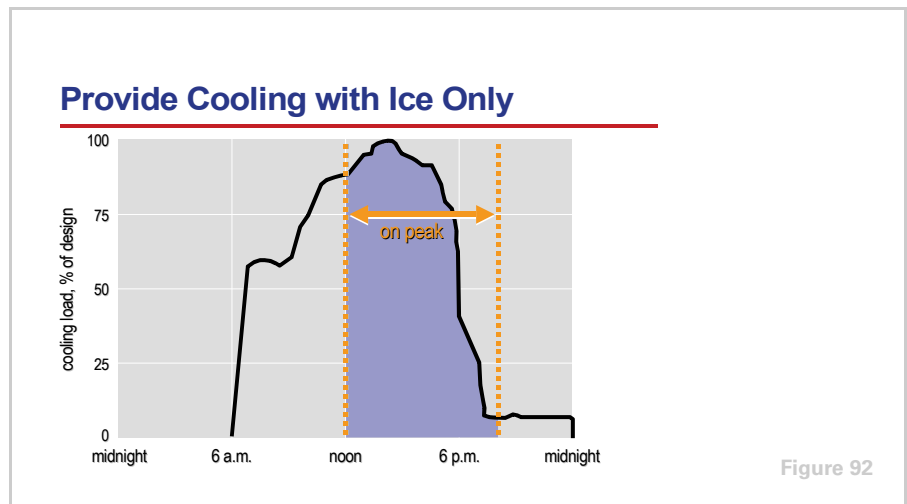

During the on-peak period, the cost of electricity is higher and there may be a demand charge. Melting the stored ice to satisfy the building cooling load,

## period five

# System Control

### notes

while turning off the electrically powered chiller, can significantly lower the operating cost of the system.

In this example, the building cooling loads that occur during the on-peak period between noon and 8 p.m. are satisfied by melting ice alone. The chiller is turned off.

This strategy, of course, is only possible in a full-storage system, where the capacity of the ice storage tanks is large enough to satisfy the on-peak cooling loads for the day.

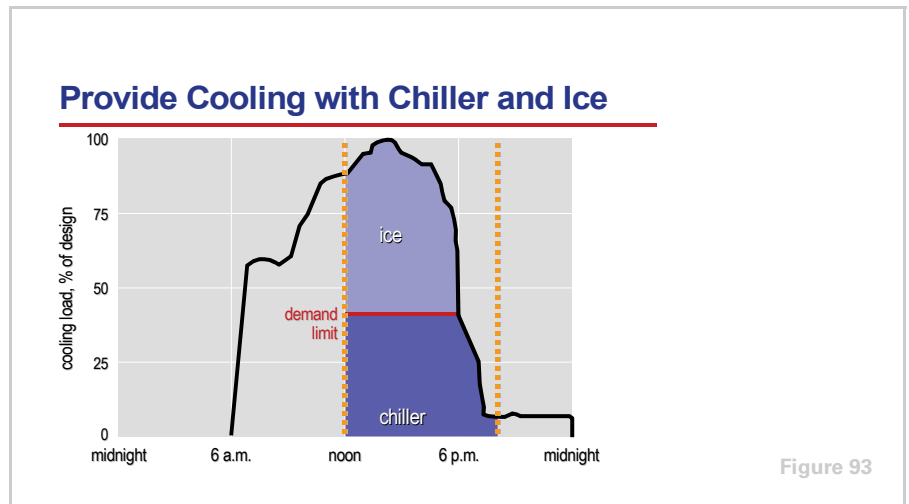

In a partial-storage system, the portion of the on-peak cooling loads satisfied by the chiller is regulated by limiting the capacity of the chiller, often referred to as demand limiting. The cooling loads above this demand-limited capacity of the chiller are satisfied by melting the stored ice. In the example shown in Figure 93, the chiller satisfies about 40 percent of the design cooling load during the on-peak period, and the ice is melted to satisfy the remainder of the loads.

On the design (or worst-case) day, a partial-storage system will use the “chiller and ice” operating mode during the on-peak period. However, on less severe (part load) days, the system may have sufficient ice storage capacity to satisfy all of the on-peak cooling requirements with the ice only, allowing the chiller to be turned off.

## period five

# System Control

### notes

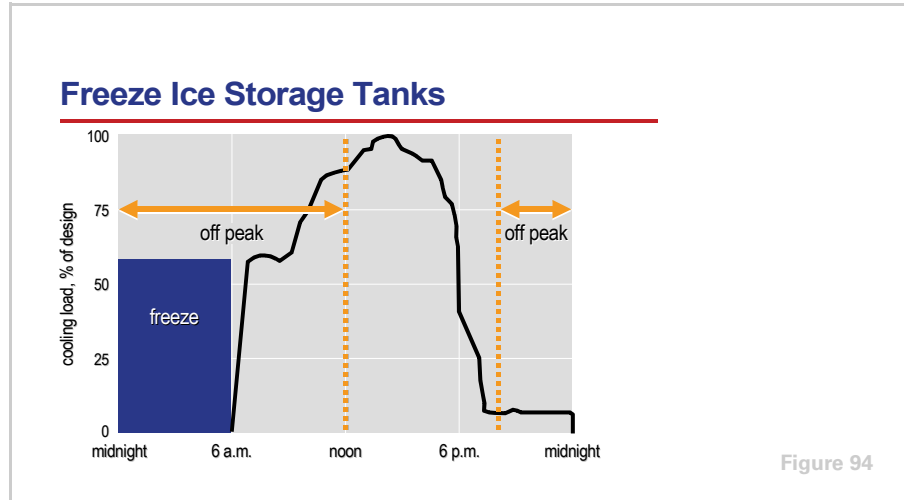

Figure 94

As mentioned previously, ice storage systems shift operation of the electrically powered chiller to off-peak periods, when it can freeze the water inside the ice storage tanks while the cost of electricity is low.

The “freeze” operating mode can be used anytime during the off-peak period. In this example, the system begins operating in “freeze” mode at midnight, and remains in this operating mode either until all the water inside the tanks is frozen or until 6 a.m., when the building cooling load is again present.

Up to this point, each operating mode has been initiated or terminated based on the time of day and its relation to the on-peak and off-peak periods. On many days, all the water inside the storage tanks will be frozen before the end of the allotted time, that is, before 6 a.m. in this example. This may occur because the capacity of the ice storage tanks was greater than the on-peak cooling requirements of the previous day. When this occurs, only a portion of the ice inside the tanks may have melted, and the system may not need to operate in “freeze” mode for the entire off-peak period.

## period five

# System Control

## notes

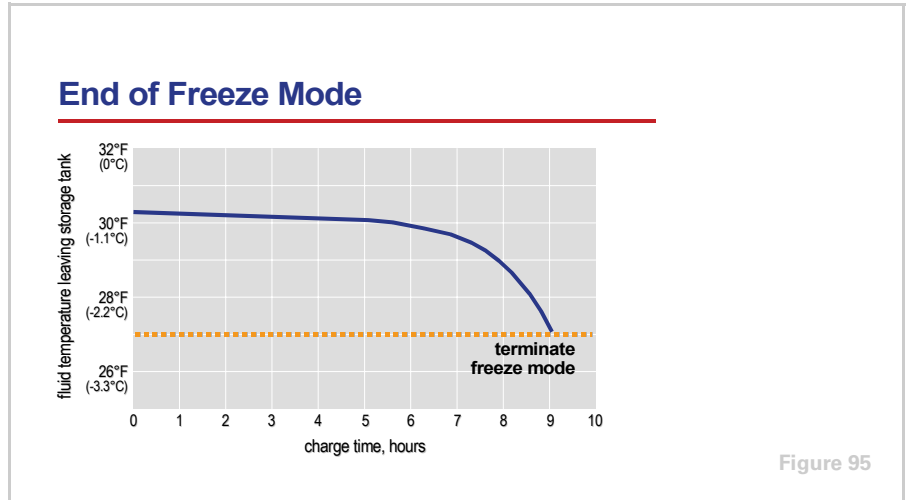

A simple, reliable, and repeatable signal is available to indicate the end of “freeze” mode. If an ample quantity of water exists inside the ice storage tank during the ice-making process, the temperature of the fluid leaving the tank will remain relatively constant. As more of the water is frozen, however, the amount of water yet to be frozen decreases, and the temperature of the fluid leaving the tank begins to drop. This leaving-fluid temperature can be used as an indicator of the amount of water yet to be frozen inside the tank and, therefore, when “freeze” mode can be terminated.

In the example shown in Figure 95, the temperature of the fluid leaving the tank begins to drop six hours after beginning “freeze” mode. When the leaving-fluid temperature drops to 27°F (-2.8°C), the water inside the ice storage tanks is considered to be frozen, and “freeze” mode can be terminated.

## period five

# System Control

### notes

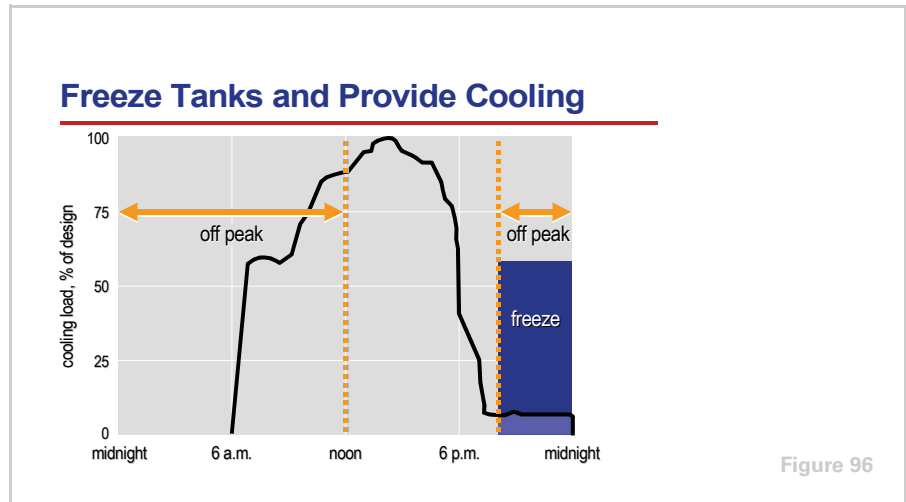

Sometimes, it may be necessary to freeze the water inside the ice storage tanks while simultaneously satisfying a building cooling load. In this example, the time required to freeze all the water inside the tanks is longer than the six-hour period from midnight to 6 a.m. Therefore, the chiller also needs to operate in ice-making mode between 8 p.m. and midnight. During this time, a building cooling load also exists.

During this “freeze and cool” mode, the chiller is operating in ice-making mode but is also satisfying the building cooling load. The system remains in this operating mode until all the water inside the tanks is frozen, or until midnight, when the building cooling load is no longer present.

#### combining tactical and strategic control

### Strategic Control Table

operating mode	start time	end time
chiller only	6 a.m.	noon
ice only	noon	8 p.m.
chiller and ice	noon	8 p.m.
chiller only	8 p.m.	midnight
freeze and cool	8 p.m.	midnight
freeze	midnight	6 a.m.
off	when building or ice-making loads are not present	

Figure 97

The strategic control table can now be filled in by indicating the start time and end time for each operating mode.

# period five

## System Control

### notes

From 6 a.m. until noon, cooling is provided by operating the chiller alone. From noon to 8 p.m., if the ice storage tanks have sufficient capacity, cooling is provided by melting the ice alone and the chiller can be turned off. Otherwise, cooling is provided by operating the chiller while simultaneously melting ice.

From 8 p.m. until midnight, the cooling is again provided by operating the chiller alone. At midnight, the system begins freezing the water inside the storage tanks. This mode continues until the temperature of the fluid leaving the tank drops to 27°F (-2.8°C), or until 6 a.m.

If “freeze” mode requires longer than the six-hour period from midnight to 6 a.m., however, the system will need to operate in “freeze and cool” mode for some portion of the time between 8 p.m. and midnight, when a building cooling load also exists.

Finally, between midnight and 6 a.m., if all the water inside the storage tanks is frozen, the system can be turned off because no building cooling load exists.

#### combining tactical and strategic control

### Overlapping Operating Modes

operating mode	start time	end time
chiller only	6 a.m.	noon
ice only	noon	8 p.m.
chiller and ice	noon	8 p.m.
chiller only	8 p.m.	midnight
freeze and cool	8 p.m.	midnight
freeze	midnight	6 a.m.
off	when building or ice-making loads are not present	

Figure 98

Notice that during some time periods, more than one operating mode might be used.

During the on-peak period between noon and 8 p.m., the building cooling load might be satisfied by melting ice alone, or by a combination of melting ice and operating the chiller. How to determine which operating mode to use will be discussed later.

During the off-peak period between 8 p.m. and midnight, the chiller may operate in cooling-only mode to satisfy the building cooling load, or it may operate in ice-making mode to freeze the water inside the ice storage tanks while simultaneously satisfying the building cooling load.

## period five

# System Control

### notes

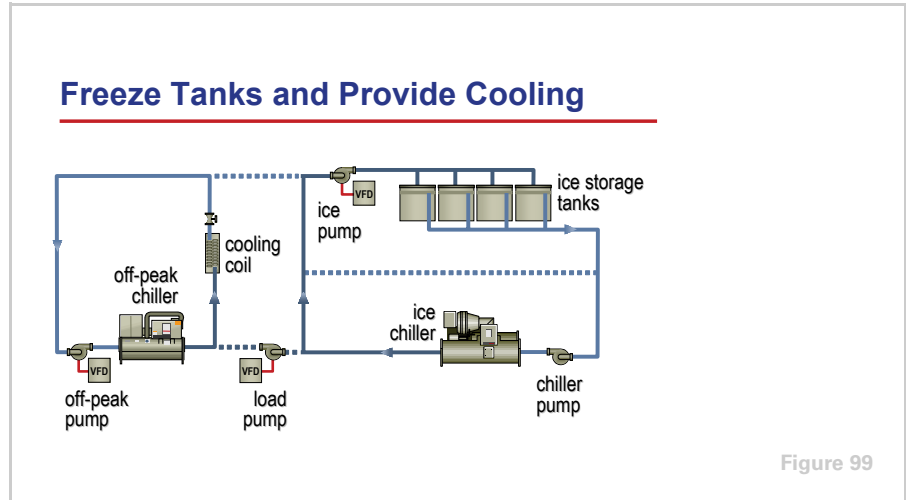

If the building cooling loads that exist during the time when the system is to be making ice are significant, it is typically advantageous to use a separate, “off-peak” chiller to satisfy these loads. The ice-making chiller is less efficient when making ice. This configuration allows the ice-making chiller to be used only for the purpose of making ice, allowing it to use its full capacity to freeze the water inside the tanks as quickly as possible.

If the system is comprised of only a single chiller, however, the “freeze and cool” operating mode may not be avoidable. In this case, consider limiting the use of the “freeze and cool” operating mode to only the hottest part of the cooling season, when the system is likely to require the extra time for freezing the water inside the tanks.

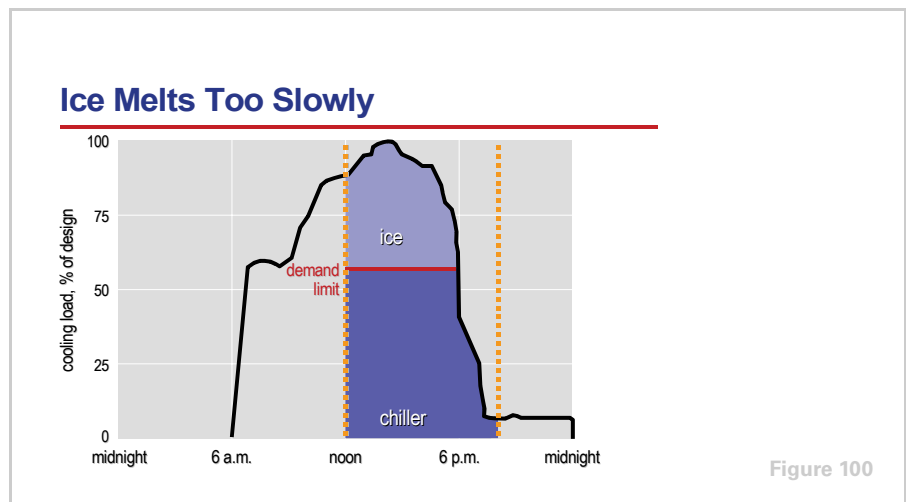

Determining whether to use the “ice only” or “chiller and ice” operating mode during the on-peak period for a given day is a more difficult decision. This, of



## period five

# System Control

### notes

course, is only an issue for a partial-storage system. A full-storage system will have enough storage capacity to satisfy the entire on-peak cooling load for the design (or worst-case) day, allowing the chiller to be turned off during this time period during every day.

If the primary mission of a partial-storage system is to reduce on-peak electrical consumption (kWh), it is typically most beneficial to melt as much of the stored ice as possible during this on-peak period. This allows the chiller to operate at the lowest capacity possible.

If the ice is melted too slowly, there may be un-melted ice remaining in the tanks at the end of the on-peak period. This means that the chiller had to operate at a higher capacity than was necessary. In the example shown in Figure 100 on page 82, the demand limit setting for the chiller is too high, causing the chiller to operate at a higher capacity than necessary. This slows the rate at which the ice melts, and unmelted ice remains in the tanks at the end of the on-peak period.

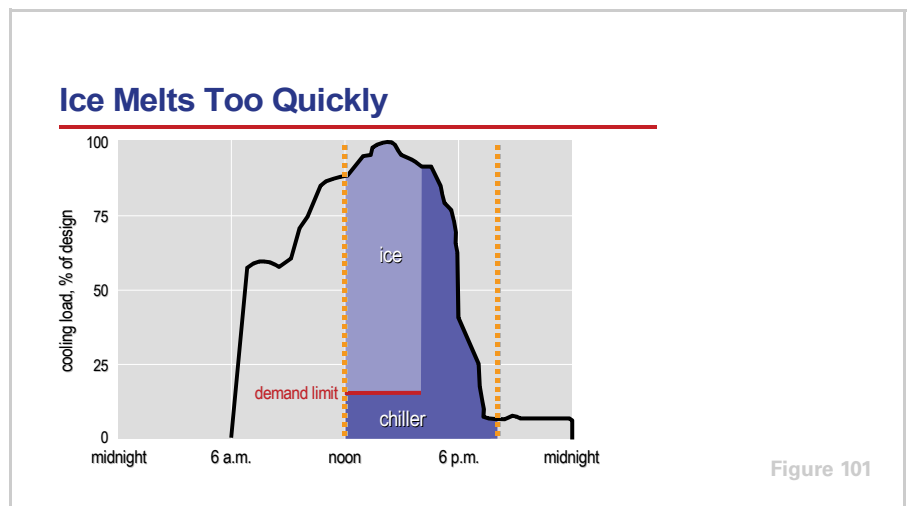

On the other hand, if the ice melts too quickly, it may be used up before the end of the on-peak period. This would cause the chiller to need to operate at a significantly higher capacity than necessary at the end of this period.

In the example shown in Figure 101, the demand limit setting for the chiller is too low, causing the ice to melt too quickly. By 4 p.m., the ice is all melted and the chiller must significantly increase its capacity to satisfy the building cooling load. If the electric utility rate structure includes an on-peak demand charge, this increase in chiller power (kW) draw may result in a higher utility bill.

## period five System Control

### notes

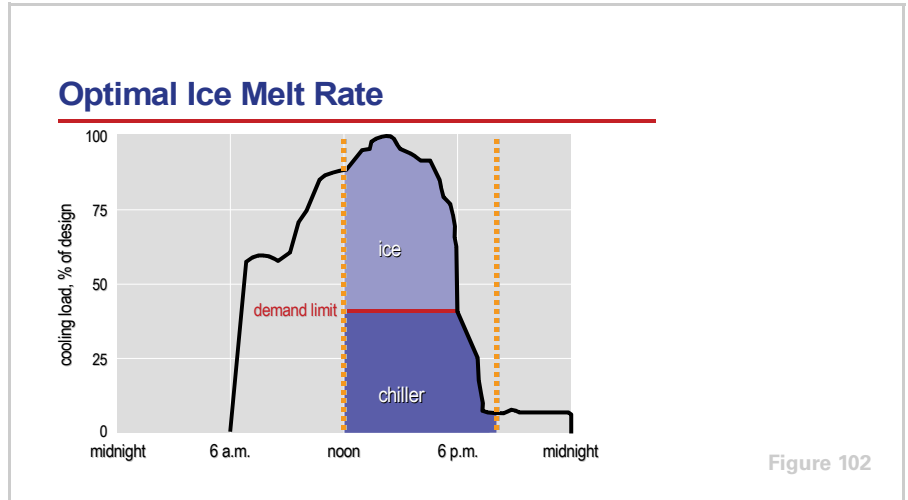

In this last example, the chiller is demand-limited to operate at a capacity that allows the ice to melt at the optimal rate, ensuring that all the ice is melted by the end of the on-peak period.

System-level controls can be used to predict this “optimal” melt rate for a given day and then demand-limit the chiller accordingly. This typically involves monitoring the building cooling load prior to the beginning of the on-peak period, and comparing that load to the load expected on the design day.

Determining whether the chiller should be operated during the on-peak period, and at what capacity it should be operated, are economic decisions. These decisions have a direct bearing on the monthly utility bill, especially when the utility rate includes a demand charge.

## period five

# System Control

### notes

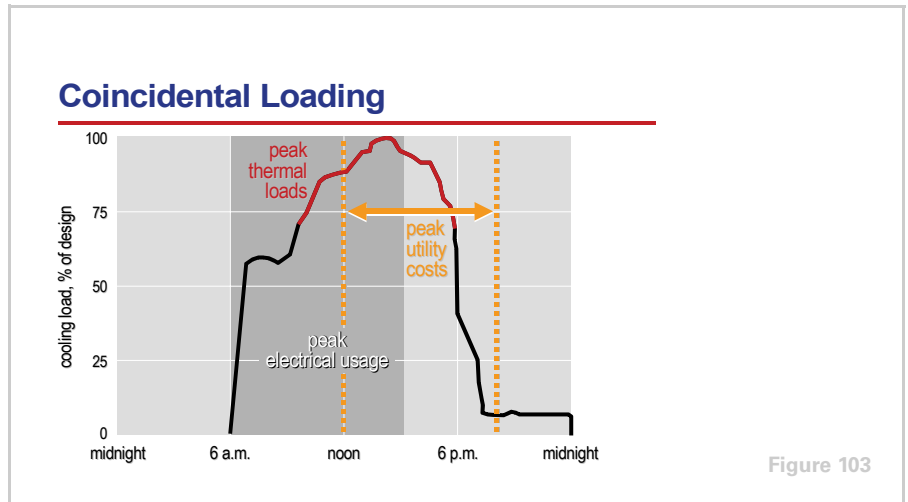

If the primary mission of a partial-storage system is to reduce on-peak electrical demand (kW), ice storage typically provides its greatest economic benefit when the building cooling load, the cost of electricity, and the building electrical load all peak simultaneously.

For this example building, while a cooling load exists from 6 a.m. until midnight, the highest cooling loads occur between 10 a.m. and 6 p.m. The on-peak electricity rate exists between noon and 8 p.m., and the highest electrical usage of the overall building starts earlier, at 6 a.m., and begins to subside by 3 p.m.

In this example, it is advantageous to melt as much ice as possible between noon and 3 p.m. After 3 p.m., the electrical use of the building is declining, and it may be possible to operate the chiller without increasing the peak electrical demand for the day.

## period five

# System Control

### notes

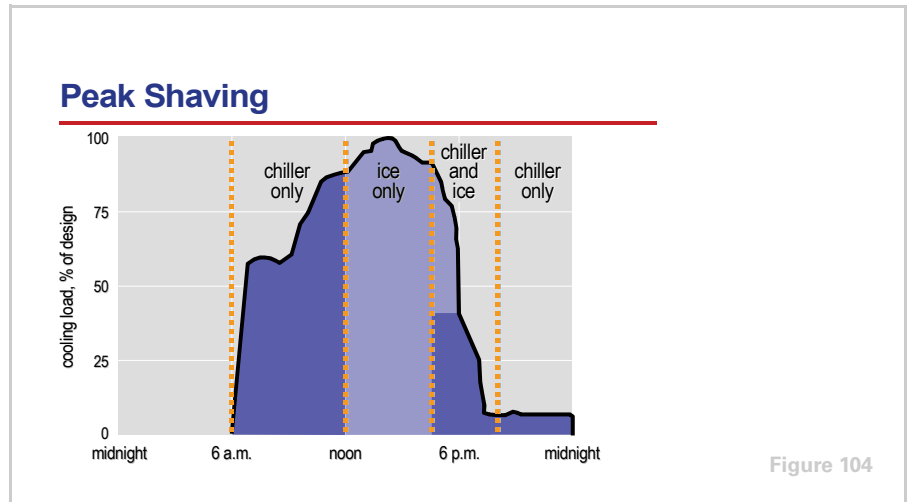

On the example day shown in Figure 104, there is sufficient ice storage capacity to meet most of the on-peak cooling loads, but not enough to meet the loads throughout the entire on-peak period. Therefore, the system uses the “ice only” operating mode between noon and 4 p.m.

As mentioned, the building electrical demand begins to decline after 3 p.m. Beginning at 4 p.m., the chiller is turned on and demand limited so that the chiller and ice combine to satisfy the cooling loads during the remainder of the on-peak period (until 8 p.m.).

Even though the chiller operates during the on-peak period, it does so at the end of the day, when the electrical demand for the rest of the building has decreased. Operating the chiller at this time did not increase the on-peak electrical demand (kW) for the building.

## period five

# System Control

## notes

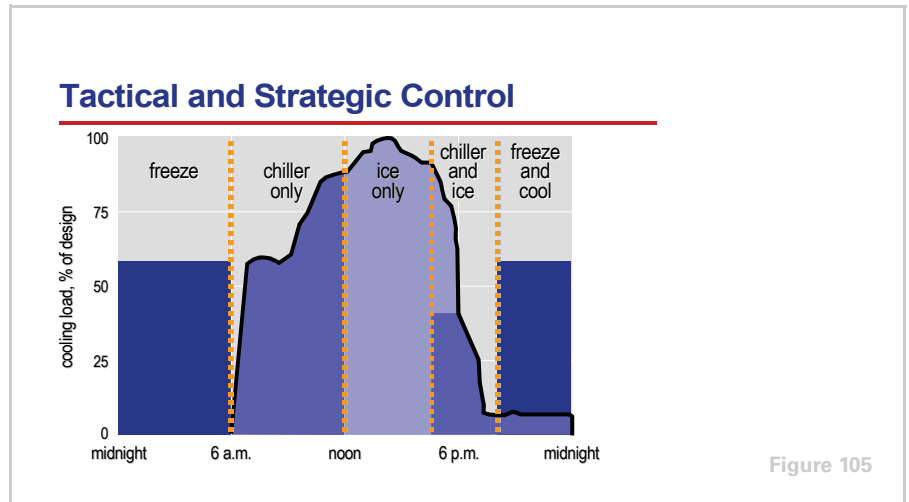

Combining tactical and strategic control defines the start time and end time for each operating mode:

- At 6 a.m. a building cooling load exists and the chiller is started to satisfy the load. The lower-cost, off-peak electrical rates continue until noon. Therefore, from 6 a.m. until noon it is most beneficial to provide cooling with the chiller only.
- Higher, on-peak utility electrical rates begin at noon. Due to these higher rates and on-peak demand charges, it is most beneficial to provide cooling by melting ice alone. The chiller is turned off. In this example, there is sufficient ice storage capacity to meet most of the on-peak cooling loads, but not enough to meet the loads throughout the entire on-peak period. The system uses the “ice only” operating mode between noon and 4 p.m.
- The building electrical demand begins to decline between 3 p.m. and 4 p.m. Beginning at 4 p.m., the chiller is turned on and demand limited so that the chiller and ice combine to satisfy the cooling loads during the remainder of the on-peak period (until 8 p.m.).
- At 8 p.m., the lower-cost, off-peak electrical rates return. At this time, the system initiates the “freeze and cool” mode to begin freezing the water inside the ice storage tanks while also satisfying the simultaneous building cooling load.
- At midnight, the building cooling load ceases and the chiller is fully devoted to freezing the water inside the storage tanks. The system remains in this “freeze” mode until all the water inside the tanks is frozen, or until 6 a.m. when the building cooling load returns.
- If the water inside the tanks is fully frozen, and no building cooling load exists, the system can be turned off.

## period six Review

---

### notes

### Ice Storage Systems

*period six*  
Review

Figure 106

We will now review the main concepts that were covered in this clinic.

### Review—Period One

▲ **Lower utility costs**

- ◆ Lower on-peak electrical consumption (kWh)
- ◆ Lower on-peak electrical demand (kW)

▲ **Smaller equipment size**

- ◆ Smaller chiller
- ◆ Smaller electrical service (A)

▲ **Reduced installed cost**

- ◆ May qualify for utility rebates or other incentives

Figure 107

Ice storage systems lower monthly utility costs by melting ice to satisfy building cooling loads during the on-peak period, when the cost of electricity is high. Operation of the chiller is shifted to the off-peak period, during which the cost of consuming electricity (kWh) is lower and the demand (kW) charge is lower or non-existent. The chiller is used during that period to freeze the water inside the storage tanks, storing the thermal energy until the on-peak period.

When ice storage is used to satisfy all or part of the design (or worst-case) cooling load, the chiller may be able to be downsized, as long as the downsized chiller has sufficient time to re-freeze the water inside the tanks. Smaller, electrically driven chillers may also result in smaller electrical service to the building, which also reduces installed cost.

## period six

# Review

### notes

While the ice storage tanks add to the system installed cost, the impact of downsizing the mechanical cooling equipment may offset some (or all) of this added cost. Additionally, some electric utility companies offer rebates or other incentives when ice storage is used to reduce on-peak electrical demand. When these incentives are available, adding ice storage may even reduce the overall installed cost of the system.

In some installations, each of these benefits might be realized. In other installations, however, maximizing one benefit may negate one or more of the other potential benefits.

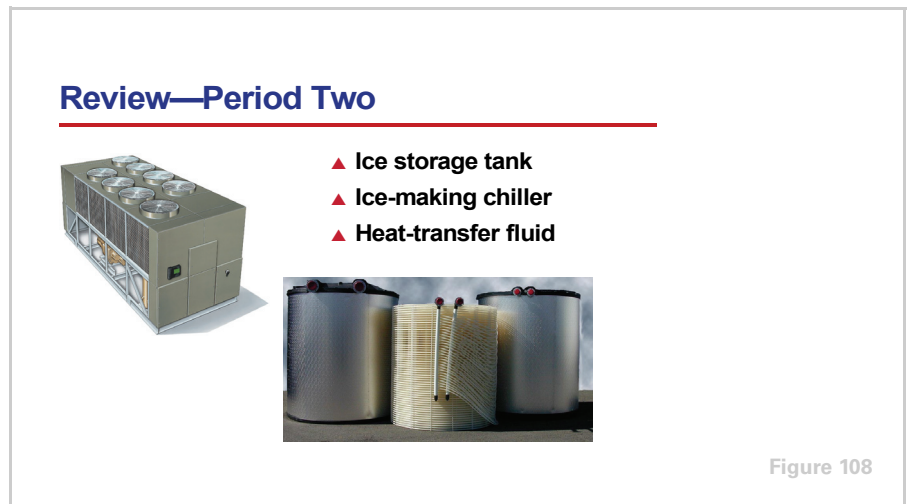

Period Two discussed the three components of a glycol-based ice storage system that are different from a conventional chilled-water system: the ice storage tank, the ice-making chiller, and a heat-transfer fluid that remains liquid at temperatures lower than the freezing point of water.

The rate at which the water inside an ice storage tank freezes is best maximized by lowering the temperature of the fluid entering the tank. Flow through the storage tank remains constant during the ice-making mode, but can then be varied to change the rate at which the ice is melted to satisfy the cooling load.

A conventional, cooling-only chiller is controlled based on the leaving-fluid temperature and its capacity is varied to meet the changing cooling load. When making ice, an ice-making chiller operates at full capacity until the entering-fluid temperature drops below a preset lower limit, indicating that all the water inside the storage tanks has frozen.

Ethylene glycol and propylene glycol are heat-transfer fluids that are commonly used in ice storage systems. Use an antifreeze that has low viscosity, and keep the concentration to the lowest acceptable level. A heat-transfer fluid that has a concentration of 25 percent ethylene glycol is preferred for most ice storage systems because it provides sufficient freeze protection while minimizing the negative effects on heat transfer in the cooling coils and chillers.

## period six

# Review

---

### notes

Propylene glycol has much poorer heat-transfer characteristics than ethylene glycol, and cannot be substituted for ethylene glycol without re-engineering the rest of the components in the system.

#### **Review—Period Three**

---

- 1. Define the mission**
- 2. Determine ice storage capacity**
- 3. Select storage tanks and chillers**

Figure 109

Period Three discussed the process used to design an ice storage system. The first step is to clearly define the mission of the ice storage system. This mission statement needs to clarify which of the potential benefits are desired, and if more than one benefit is desired, which is most important.

The second step in designing an ice storage system is to define the required storage capacity by evaluating the specific application in terms of the space available for the tanks, the impact on the overall installed cost of the system, and the impact on life-cycle cost. A full-storage system has sufficient ice storage capacity to satisfy the entire on-peak cooling requirement. This would allow the chiller to be turned off altogether during the on-peak period. For most installations, however, the installed cost or space requirements of a full-storage system may not be feasible. A partial-storage system uses both the chiller and ice storage tanks to satisfy the on-peak cooling requirement. Computerized, hourly energy-analysis programs are very helpful when determining the optimum storage capacity for a partial-storage system.

The third step is to actually select the storage tanks and chillers. Selecting the ice storage tanks for the required freeze rate and melt rate, and selecting the ice-making chiller to balance with the tank freeze rate, involves a cooperative and iterative process using the chiller selection software and ice storage tank selection software.



## period six

# Review

### notes

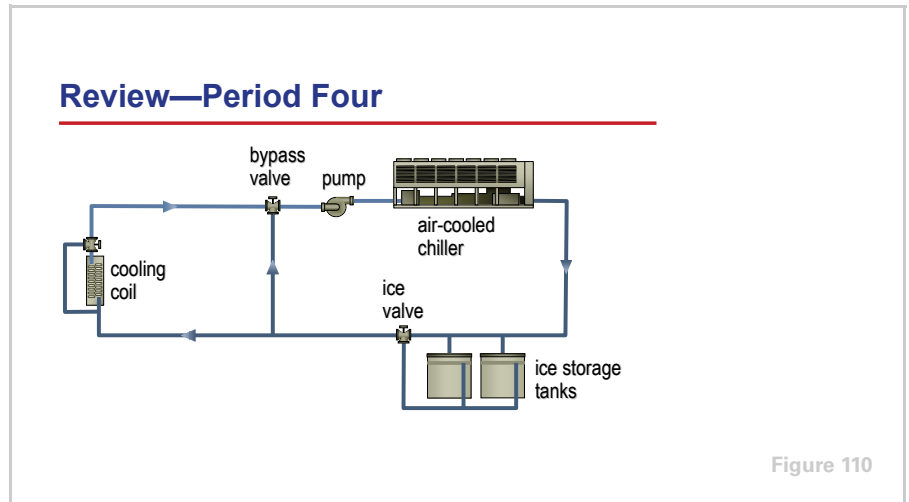

Period Four discussed the typical layouts of small and large ice storage systems. The ice storage tanks are normally configured in series with the chiller, either upstream or downstream of the chiller depending on the application. Locating the tanks upstream of the chiller allows the tanks to operate at a higher leaving-fluid temperature, which increases the storage capacity of the tanks. However, locating the tanks downstream allows the chiller to operate at a higher leaving-fluid temperature, which increases chiller capacity and efficiency.

In small systems that use helical-rotary or scroll chillers, locate the tanks downstream of the chillers. The increase in capacity and efficiency that results from locating the chiller upstream is more pronounced in a chiller that uses a positive-displacement compressor than in a chiller that uses a centrifugal compressor. And, because the system contains only a few tanks, the increased storage capacity of locating the tanks upstream has only a minimal impact on the installed cost of the system.

In large systems that use centrifugal chillers, locate the tanks upstream of the chillers. Because the system contains a large number of tanks, locating the tanks upstream has a more significant impact on the number of tanks required and, therefore, the installed cost of the system. In addition, the impact of colder fluid temperatures on the capacity and efficiency of a centrifugal chiller is not as pronounced as in a chiller that uses a positive-displacement compressor.

## period six

# Review

## notes

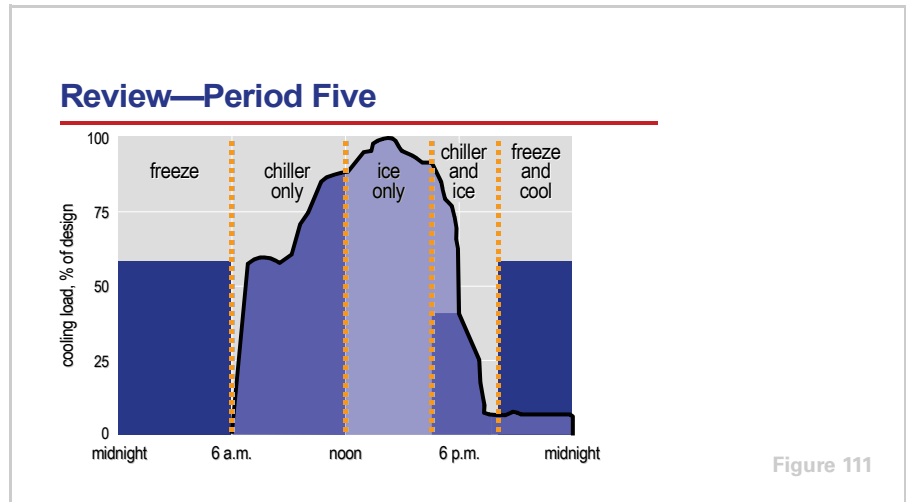

Period Five discussed the control of an ice storage system by introducing the concepts of tactical control and strategic control. Tactical control defines *how* to perform a certain function. Strategic control defines *when* to perform that function.

To understand the tactical control of an ice storage system, a table was constructed to define the required action for each of the controlled components (valves, chillers, pumps, and so on) during each of six system operating modes: chiller only, ice only, chiller and ice, freeze, freeze and cool, and off.

To understand the strategic control of an ice storage system, a second table was constructed to define the start time and end time of each operating mode. These times depend on many factors, including on-peak versus off-peak electrical rates, the building cooling-load profile, and the demand of other electrically powered equipment in the building.

Finally, tactical and strategic controls are combined to determine how the system is to be controlled. Some operating modes, however, do not necessarily begin or end based on the time of day, and may require other means to signal when to switch to a different operating mode. For example, the temperature of the fluid leaving the ice storage tanks is monitored to determine when to terminate "freeze" mode.

## period six **Review**

---

### notes



For more information, refer to the following references:

- *Ice Storage Systems Applications Engineering Manual* (Trane literature order number SYS-AM-10)
- *Control of Ice Storage Systems Applications Engineering Manual* (ICS-AM-4)
- *Multiple-Chiller-System Design and Control Applications Engineering Manual* (SYS-APM001-EN)
- *Chilled-Water Systems Air Conditioning Clinic* (TRG-TRC016-EN)
- ASHRAE Handbook – HVAC Applications

Visit the ASHRAE Bookstore at [www.ashrae.org](http://www.ashrae.org).

For more information on additional educational materials available from Trane, contact your local Trane office (request a copy of the Educational Materials catalog – Trane literature order number EM-ADV1) or visit our online bookstore at [www.trane.com/bookstore/](http://www.trane.com/bookstore/).

# Quiz

---

## Questions for Period 1

- 1** The hours when the cost of electricity is highest are often referred to as the \_\_\_\_\_ period.
- 2** List two potential benefits of an ice storage system.

## Questions for Period 2

- 3** Lowering the temperature of the heat-transfer fluid entering an ice storage tank \_\_\_\_\_ (speeds up or slows down) the rate at which the water inside the tank freezes.
- 4** Reducing the rate at which the heat-transfer fluid flows through an ice storage tank \_\_\_\_\_ (speeds up or slows down) the rate at which the water inside the tank freezes.
- 5** The capacity of a chiller when operating in ice-making mode is \_\_\_\_\_ (greater than or less than) its capacity when operating in conventional cooling mode.
- 6** True or False: Propylene glycol has better heat-transfer characteristics than ethylene glycol.
- 7** True or False: Reducing the temperature of the fluid entering the cooling coil helps recover some (or all) of the capacity lost when antifreeze is added to the heat-transfer fluid.

## Questions for Period 3

- 8** Which of the following (select all that apply) are reasons why an ice-making chiller should be operated at maximum capacity when it is in ice-making mode?
  - a** Minimize energy used by the ancillary equipment (such as pumps, condenser fans, or cooling tower fans)
  - b** Avoid surge, if using a centrifugal chiller
  - c** Ensure stable operation of the chiller

## Questions for Period 4

- 9** When the ice storage tanks are located in series with the chiller(s), locating the tanks upstream, rather than downstream, of the chiller(s) \_\_\_\_\_ (speeds up or slows down) the melt rate of the tank, therefore \_\_\_\_\_ (increasing or decreasing) the storage capacity of a given tank size.

## Quiz

---

- 10** Which of the following (select all that apply) are benefits of using an intermediate heat exchanger when retrofitting an existing system with ice storage?
- a** Protects ice storage tanks from high pressures generated by existing pumping system
  - b** Avoids pumping the antifreeze-and-water solution throughout the existing piping system
  - c** Avoids reducing the capacity of existing cooling coils

### Questions for Period 5

- 11** Near the end of the ice-making process, the temperature of the fluid leaving the tank begins to \_\_\_\_\_ (increase or decrease).
- 12** When the ice is being melted to satisfy all or part of the building cooling load, reducing the rate at which the heat-transfer fluid flows through the storage tank \_\_\_\_\_ (speeds up or slows down) the rate at which the ice inside the tank melts.

## Answers

---

- 1** on-peak
- 2** Lower monthly utility costs, smaller equipment size, lower installed cost
- 3** speeds up
- 4** slows down
- 5** less than
- 6** False
- 7** True
- 8** a, b, and c
- 9** slows down, increasing
- 10** a, b, and c
- 11** decrease
- 12** slows down

# Glossary

---

**approach** The difference in the temperature of the heat-transfer fluid leaving the ice storage tank and the temperature of the storage medium, typically water, inside the tank.

**“baseline” chiller** A conventional, cooling-only chiller in an ice storage system that is used to satisfy a large portion (or all) of the daily cooling loads that are not satisfied by melting stored ice.

**building automation system (BAS)** A centralized control and monitoring system for a building.

**centrifugal compressor** A type of compressor that uses centrifugal force, generated by a rotating impeller, to compress the refrigerant vapor.

**chilled-water system** A system that uses water as the cooling media. The refrigerant inside the evaporator absorbs heat from the water, and this water is pumped to cooling coils in order to absorb heat from the air used for space conditioning.

**coil  $\Delta T$**  The increase in the temperature of the heat-transfer fluid from the inlet to the outlet of the cooling coil.

**compressor** A mechanical device in the refrigeration system used to increase the pressure and temperature of the refrigerant vapor.

**compressor lift** The difference in refrigerant pressure between the evaporator and condenser.

**cooling tower** A device used to reject the heat from a water-cooled condenser by spraying the condensing water over fill while drawing outdoor air upward through the slats.

**expansion valve** The component of the refrigeration system that maintains the pressure difference between the high-pressure and low-pressure sides of the system, and maintains the proper amount of superheat in the system by metering the quantity of liquid refrigerant entering the evaporator, ensuring it will be completely vaporized within the evaporator.

**freeze  $\Delta T$**  The increase in the temperature of the heat-transfer fluid from the inlet to the outlet of the ice storage tank.

**freeze rate** The rate at which the water inside an ice storage tank freezes, in tons (kW).

**full-storage system** An ice storage system that has sufficient storage capacity to satisfy all of the on-peak cooling loads for the design (or worst-case) day, allowing the chiller(s) to be turned off.

**helical-rotary compressor** A type of compressor that uses two mated rotors to trap the refrigerant vapor and compress it by gradually shrinking the volume of the refrigerant.

## Glossary

---

**ice-making chiller** A refrigeration machine that is capable of cooling a heat-transfer fluid to temperatures well below the freezing point of water.

**ice storage tank** A vessel that contains a heat exchanger used to freeze water during one part of the day, and then melt the ice during another part of the day. This heat exchanger is typically constructed of steel, polyethylene, or polypropylene tubes that are connected to a common header.

**impeller** The rotating component of a centrifugal compressor that draws refrigerant vapor into its internal passages and accelerates the refrigerant as it rotates, increasing its velocity and kinetic energy.

**“load-balancing” chiller** A conventional, cooling-only chiller in an ice storage system that is sized to provide just enough cooling capacity to meet the portion of the design-day cooling load that is not satisfied by melting stored ice.

**load shifting** A strategy for operating an ice storage system that attempts to reduce on-peak electrical consumption as much as possible, by melting all of the ice during the on-peak period and shifting chiller operation to the off-peak period.

**melt rate** The rate at which the ice inside an ice storage tank melts, in tons (kW).

**partial-storage system** An ice storage system that has storage capacity to satisfy only part of the on-peak cooling loads for the design (or worst-case) day. The remaining loads are satisfied by operating one or more chillers.

**peak shaving** A strategy for operating an ice storage system that attempts to find the optimum balance between reducing on-peak electrical demand (by melting ice and operating the chiller at reduced capacity) and avoiding significantly increasing off-peak electrical consumption (which happens when the chiller needs to operate in ice-making mode).

**positive-displacement compressor** A class of compressors that works on the principle of trapping the refrigerant vapor and squeezing (compressing) it by gradually shrinking the volume of the refrigerant.

**reciprocating compressor** A type of compressor that uses a piston that travels up and down inside a cylinder to compress the refrigerant vapor.

**scroll compressor** A type of compressor that uses two opposing scrolls to trap the refrigerant vapor and compress it by gradually shrinking the volume of the refrigerant.

**static tank** A closed vessel in which the ice serves only as a medium to store thermal energy. The water that results from the ice melting does not leave the tank. The ice is typically stored within the same vessel that holds the heat exchanger.

**strategic control** Defines *when* to perform a certain function.



## Glossary

---

**surge** A condition of unstable compressor operation in which the refrigerant alternately flows backward and forward through the compressor impeller, generating noise and vibration.

**tactical control** Defines *how* to perform a certain function.







Trane optimizes the performance of homes and buildings around the world. A business of Ingersoll Rand, the leader in creating and sustaining safe, comfortable and energy efficient environments, Trane offers a broad portfolio of advanced controls and HVAC systems, comprehensive building services, and parts. For more information, visit [www.Trane.com](http://www.Trane.com).

Trane has a policy of continuous product and product data improvement and reserves the right to change design and specifications without notice.

© 2012 Trane All rights reserved  
TRG-TRC019-EN 24 Aug 2012  
Supersedes TRG-TRC019-EN (Jan 2006)

We are committed to using environmentally  
conscious print practices that reduce waste.

