

Air Conditioning Clinic

Psychrometry

One of the Fundamental Series

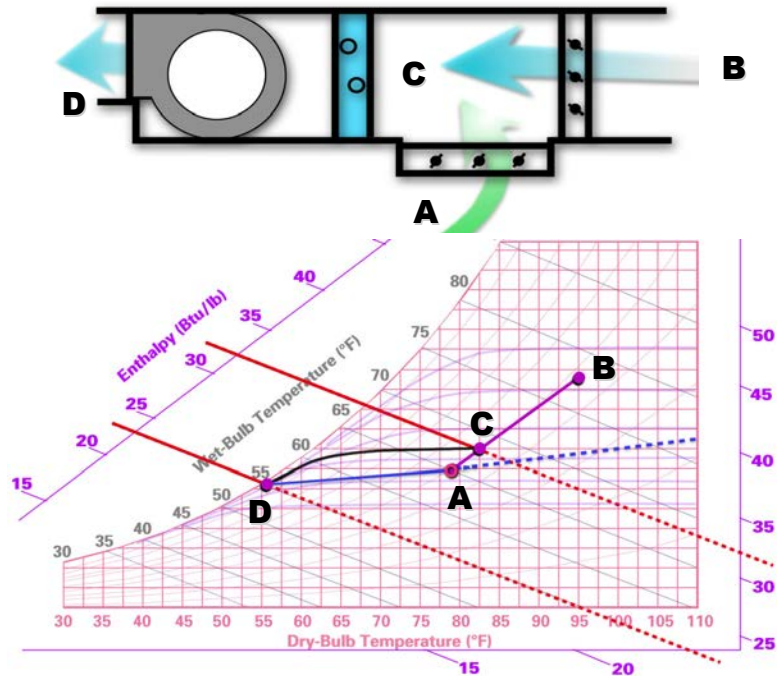



Psychrometry

One of the Fundamental Series

A publication of Trane

Preface

Psychrometry

A Trane Air Conditioning Clinic

Figure 1

Trane believes that it is incumbent on manufacturers to serve the industry by regularly disseminating information gathered through laboratory research, testing programs, and field experience.

The Trane Air Conditioning Clinic series is one means of knowledge sharing. It is intended to acquaint a nontechnical audience with various fundamental aspects of heating, ventilating, and air conditioning.

We've taken special care to make the clinic as uncommercial and straightforward as possible. Illustrations of Trane products only appear in cases where they help convey the message contained in the accompanying text.

This particular clinic introduces the concept of **psychrometry**, the science concerned with the physical laws that govern air – water mixtures.

Contents

| | | |
|--------------|--|----|
| period one | The Psychrometric Chart | 1 |
| | Properties of Air | 2 |
| | Constructing a Simple Psychrometric Chart | 8 |
| | Effect of Sensible Heat and Moisture Changes | 15 |
| period two | Air Mixtures | 18 |
| period three | Sensible Heat Ratio | 22 |
| period four | Air Quantity | 30 |
| period five | Tons of Refrigeration | 37 |
| period six | Psychrometric Analyses | 42 |
| period seven | Review | 52 |
| | Quiz | 57 |
| | Answers | 59 |
| | Glossary | 64 |



period one

The Psychrometric Chart

notes

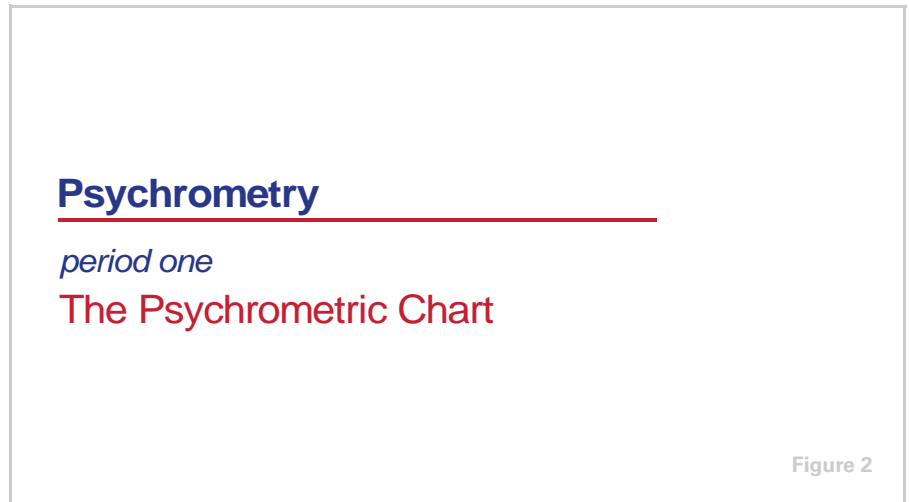

Psychrometry is the science dealing with the physical laws of air – water mixtures.

When designing an air conditioning system, the temperature and moisture content of the air to be conditioned, and the same properties of the air needed to produce the desired air conditioning effect, must be known. Once these properties are known, the air conditioning task can be determined. This analysis can be performed using the **psychrometric chart**. The psychrometric chart graphically displays several physical properties of air over a broad range of conditions. Knowing the relationship of these air properties aids the task of air conditioning system design and analysis.

period one
The Psychrometric Chart

notes

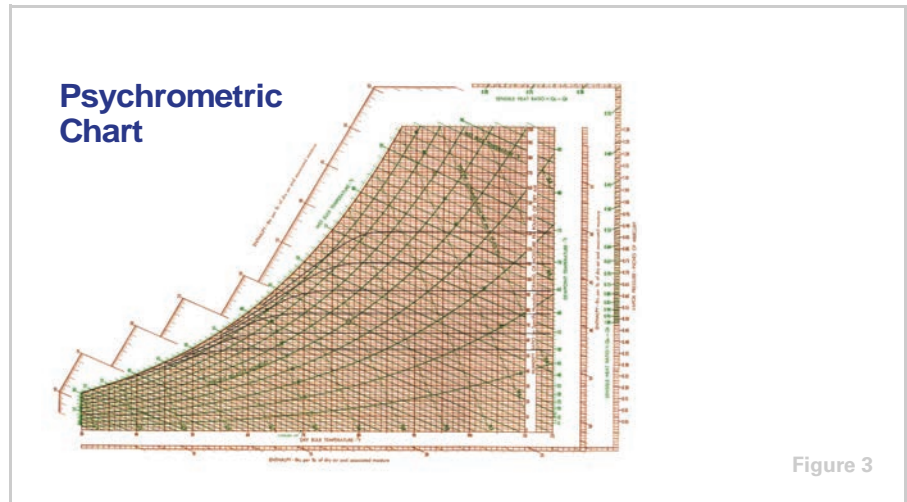

Properties of Air

At first glance, the psychrometric chart appears to be an imposing network of lines. When properly used, however, it provides valuable information about the properties of air. During this session, the psychrometric chart and its use in solving many air conditioning problems will be explained.

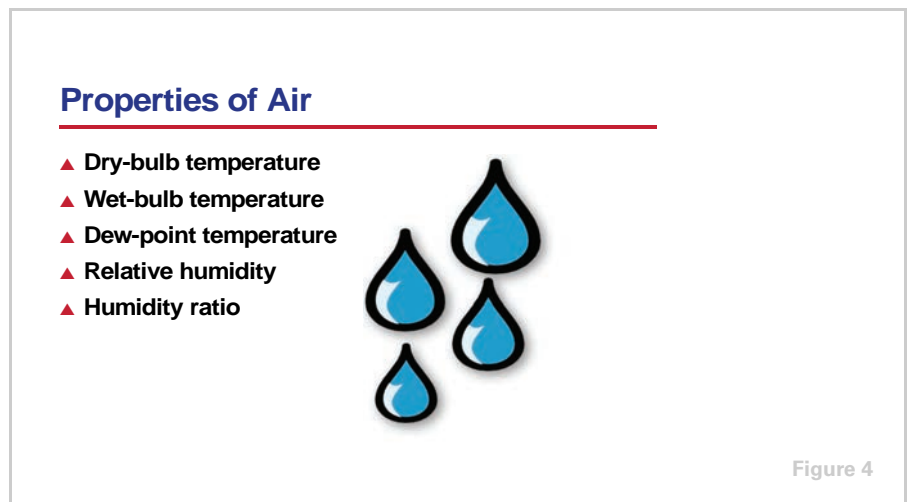

The psychrometric chart contains five physical properties to describe the characteristics of air:

- Dry-bulb temperature
- Wet-bulb temperature
- Dew-point temperature
- Relative humidity
- Humidity ratio

period one

The Psychrometric Chart

notes

Dry-Bulb Thermometer



Figure 5

Dry-bulb temperatures are read from an ordinary thermometer that has a dry bulb.

Wet-Bulb Thermometer



Figure 6

Wet-bulb temperatures are read from a thermometer whose bulb is covered by a wet wick. The difference between the wet-bulb temperature and the dry-bulb temperature is caused by the cooling effect produced by the evaporation of moisture from the wick. This evaporation effect reduces the temperature of the bulb and, therefore, the thermometer reading.

Consequently, the difference between dry-bulb and wet-bulb temperature readings is a measure of the dryness of air. The drier the air, the greater the difference between the dry-bulb and wet-bulb readings.

period one
The Psychrometric Chart

notes

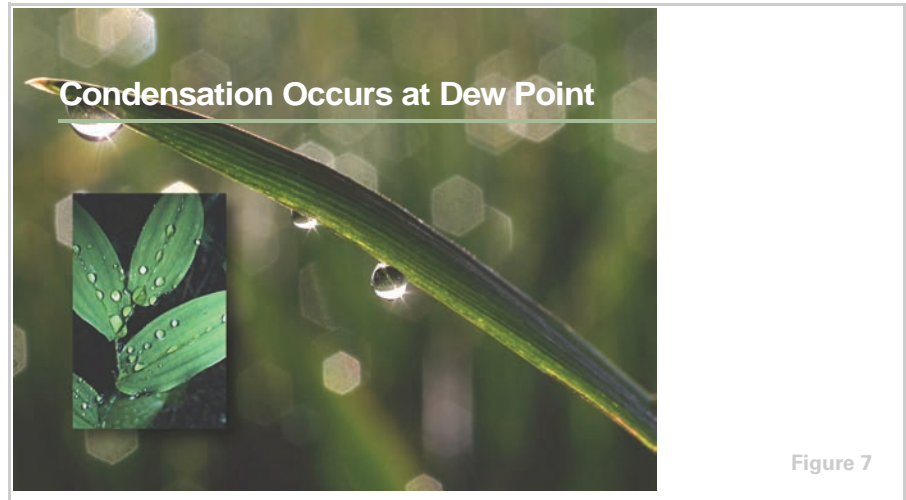

The third property, **dew-point temperature**, is the temperature at which moisture leaves the air and condenses on objects, just as dew forms on grass and plant leaves.



When the dry-bulb, wet-bulb, and dew-point temperatures are the same, the air is **saturated**. It can hold no more moisture. When air is at a saturated condition, moisture entering the air displaces moisture within the air. The displaced moisture leaves the air in the form of fine droplets. When this condition occurs in nature, it is called fog.

period one
The Psychrometric Chart

notes

Relative Humidity

$$\text{Relative Humidity} = \frac{\text{Amount of moisture that a given amount of air is holding}}{\text{Amount of moisture that a given amount of air can hold}}$$

Figure 9

The fourth property, **relative humidity**, is a comparison of the amount of moisture that a given amount of air *is* holding, to the amount of moisture that the same amount of air *can* hold, at the same dry-bulb temperature.

Relative Humidity

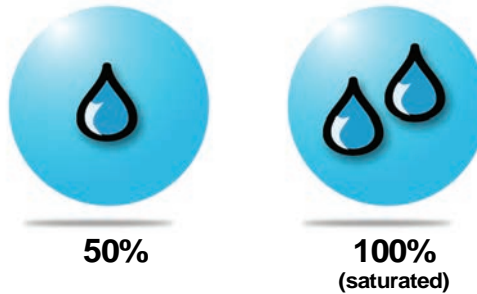

Figure 10

Relative humidity is expressed as a percentage. For example, if the relative humidity of the air is 50%, it contains one-half the amount of moisture possible at the existing dry-bulb temperature.

period one
The Psychrometric Chart

notes

Humidity Ratio



Figure 11

Finally, **humidity ratio** describes the actual weight of water in an air – water vapor mixture. In other words, if one pound of air were wrung completely dry, comparing the weight of the water to the weight of the dry air would yield its humidity ratio.

Humidity ratio can be expressed as pounds of moisture per pound of dry air, or as grains of moisture per pound of dry air. There are 7000 grains of water in a pound. To appreciate the magnitude of these units of measurement, at sea level one pound of 70°F air occupies approximately 13.5 cubic feet, and one grain of water in that air weighs about two-thousandths (0.002) of an ounce.

Properties of Air

- ▲ Dry-bulb temperature
- ▲ Wet-bulb temperature
- ▲ Dew-point temperature
- ▲ Relative humidity
- ▲ Humidity ratio



Figure 12

When any two of the first four properties of air are known, the others can be quickly determined from the psychrometric chart.

period one

The Psychrometric Chart

notes

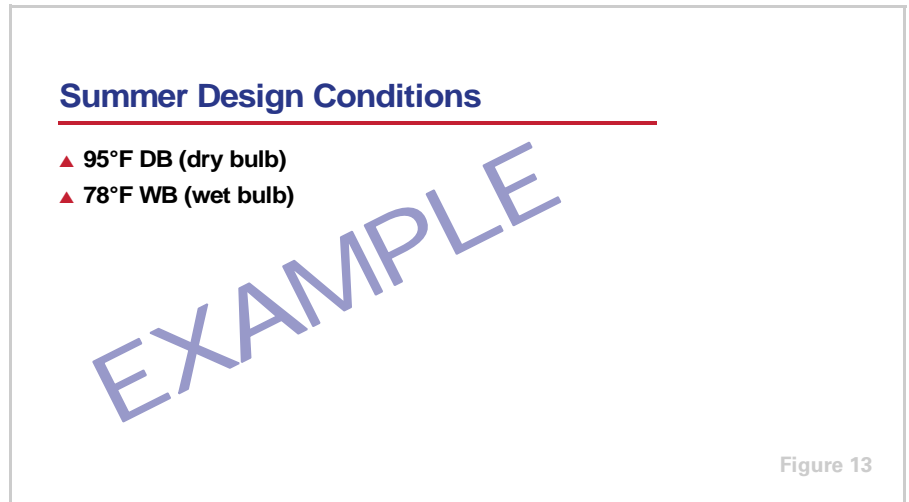

For example, let's assume that the summer design conditions are 95°F dry bulb and 78°F wet bulb.

What is the relative humidity, humidity ratio, and dew point?

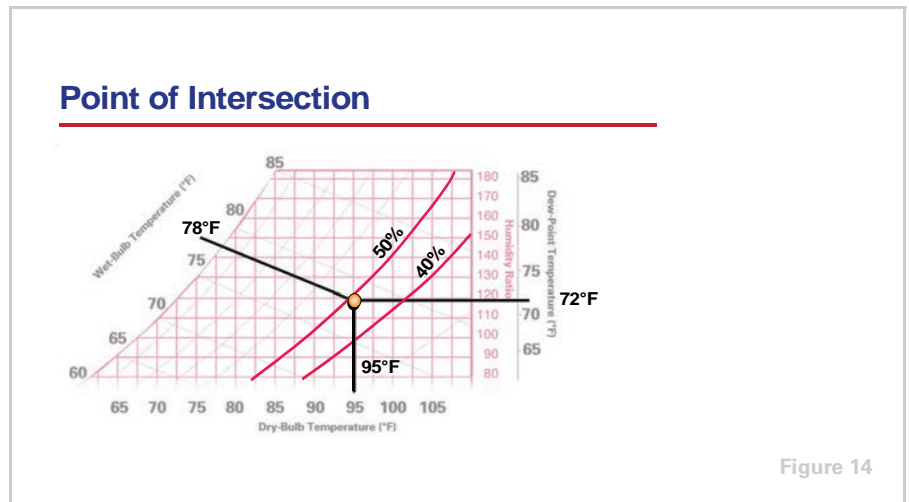

Only one point on the psychrometric chart represents air with both of these conditions. This point is located where the vertical 95°F dry-bulb (DB) and diagonal 78°F wet-bulb (WB) temperature lines intersect.

From this intersection, the remaining three air properties can be read from the chart. Both the dew-point and humidity-ratio lines are horizontal and the values are shown on the right side of the chart. In this example, the humidity ratio is about 118 grains of moisture per pound of dry air and the dew-point temperature is approximately 72°F.

period one

The Psychrometric Chart

notes

Notice that the point of intersection falls between two relative humidity curves: 40% and 50%. By interpolation, the relative humidity at this condition is approximately 47%.

Constructing a Simple Psychrometric Chart

To better understand the psychrometric chart and show why the lines intersect as they do, we will construct a simple chart.

Properties of Saturated Air

| dry-bulb temp. | humidity ratio | dry-bulb temp. | humidity ratio |
|----------------|----------------|----------------|----------------|
| 25°F | 19.14 | 60°F | 77.61 |
| 30°F | 24.19 | 65°F | 92.89 |
| 35°F | 29.94 | 70°F | 110.82 |
| 40°F | 36.51 | 75°F | 131.83 |
| 45°F | 44.34 | 80°F | 156.38 |
| 50°F | 53.63 | 85°F | 185.03 |
| 55°F | 64.63 | 90°F | 218.42 |

Figure 15

The amount of moisture contained in saturated air depends on dry-bulb temperature. This table shows the maximum amount of water vapor that one pound of dry air can hold at various dry-bulb temperatures. For example, at 25°F, one pound of dry air can absorb and hold 19.14 grains of water; at 30°F it can absorb 24.19 grains; at 35°F it can absorb 29.94 grains; and so on. Each of these conditions is a **saturation point**.

period one

The Psychrometric Chart

notes

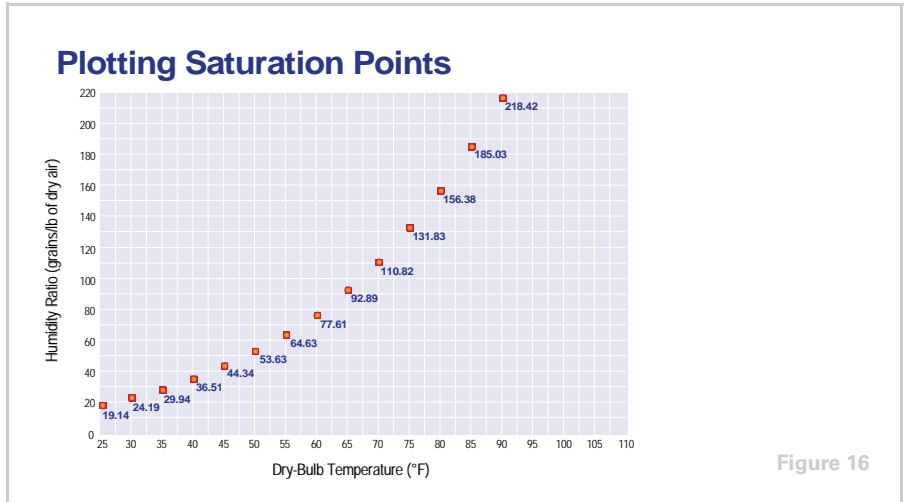

These saturation points can be plotted on a chart with dry-bulb temperature along the horizontal axis and humidity ratio along the vertical axis.

When several saturation points are plotted, the curve created resembles the relative humidity curves of the psychrometric chart.

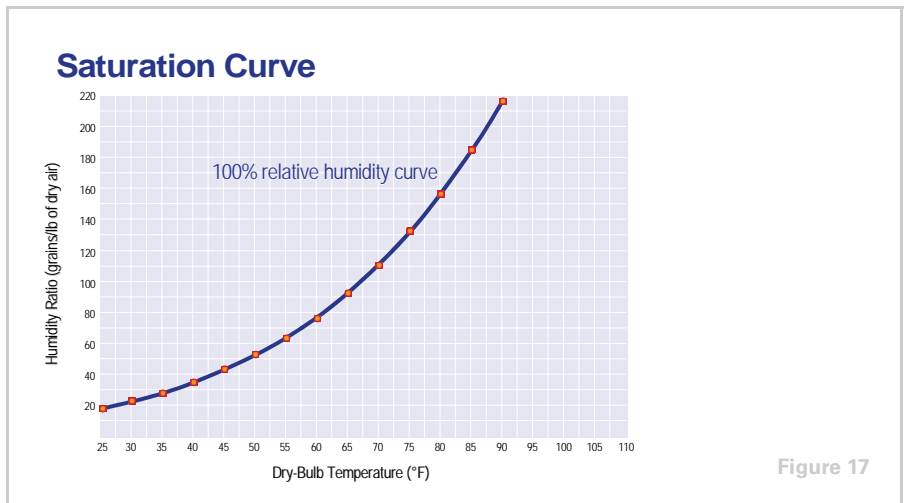

In fact, this curve forms the 100% relative-humidity curve or **saturation curve**. All points on this curve represent the moisture content that constitutes complete saturation of air at the various dry-bulb temperatures.

period one

The Psychrometric Chart

notes

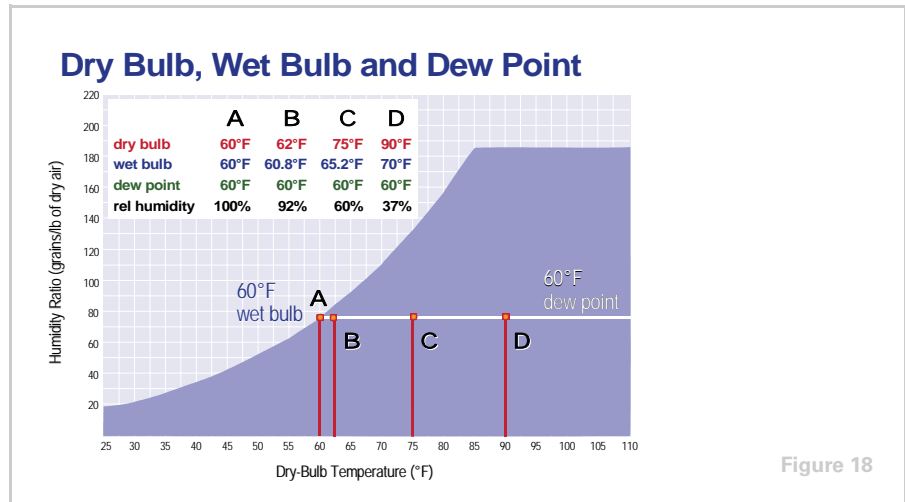

Another fact about saturated air should be discussed before we proceed.

Assume a volume of moist air has the initial conditions indicated in column **D** of the table. The air has a 90°F dry-bulb temperature and a 60°F dew point. A wet-bulb thermometer shows the wet-bulb temperature to be 70°F. From a moisture-content table, the relative humidity of the air is approximately 37%.

With no change in the moisture content of this volume of air, the table shows the progressive change that occurs as the air cools.

Point C: As the dry-bulb temperature drops from 90°F to 75°F, the wet-bulb temperature drops from 70°F to 65.2°F, yet the dew point remains the same at 60°F. The relative humidity rises from 37% to 60%.

Point B: When the dry-bulb temperature reaches 62°F, the wet-bulb temperature is about 60.8°F, the dew point remains constant at 60°F, and the relative humidity is 92%.

Point A: Finally, when the dry-bulb temperature reaches the 60°F dew-point temperature, the wet bulb cannot be reduced any lower because evaporation can no longer occur: the air is saturated and contains all the moisture it can hold. The relative humidity is now 100%.

At any point on a 100% relative-humidity curve, the three air temperatures—dry bulb, wet bulb and dew point—are equal.

period one

The Psychrometric Chart

notes

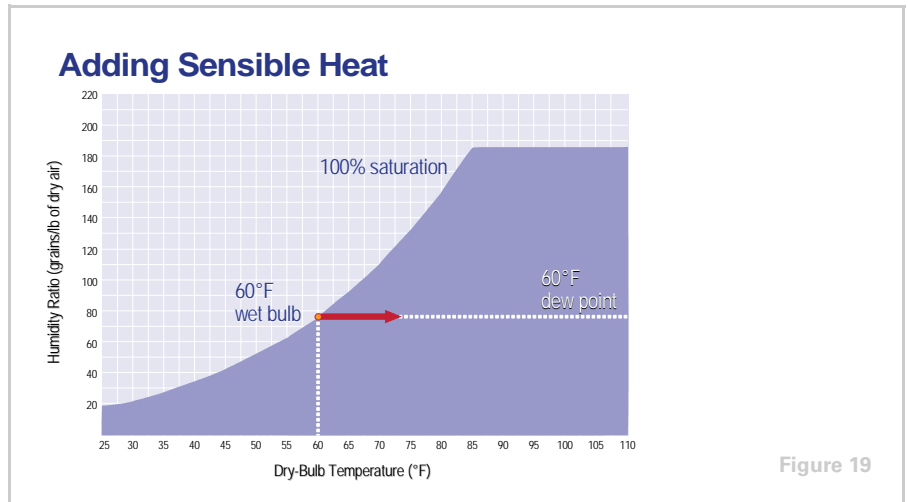

Additionally, the dew-point temperature does not change as the dry-bulb temperature changes, provided that the moisture content of the air remains the same. Merely heating the air does not change its moisture content. Therefore, as the air is heated, its condition will move horizontally along a constant humidity-ratio line.

In this example, heating 60°F saturated air moves the air condition along a horizontal humidity-ratio line that corresponds to a constant 77.56 grains of moisture per pound of dry air.

Horizontal lines can be drawn from each saturation point across to the right side of the chart. A horizontal line can be provided for each humidity-ratio value.

period one

The Psychrometric Chart

notes

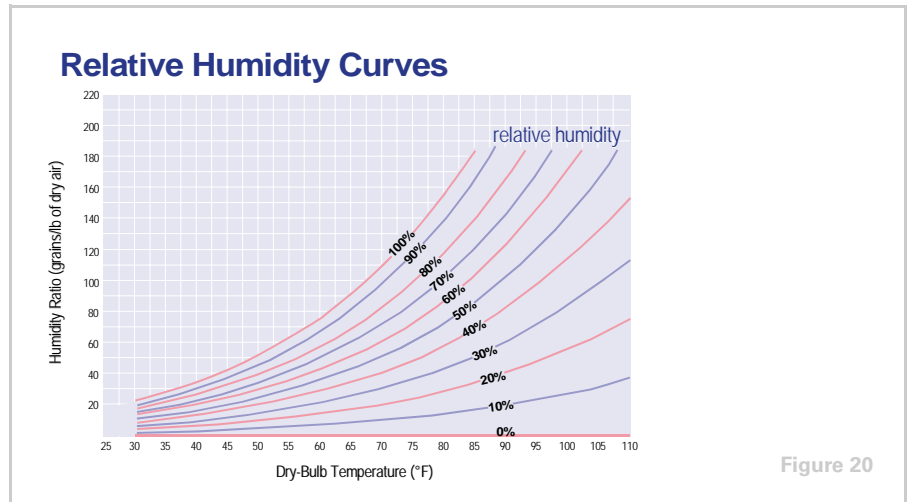

Additional curves can be added to the chart to represent relative humidity conditions that are less than 100%. The curves shown are at 10% intervals and represent humidity conditions ranging from completely saturated air to completely dry air. When air is completely dry, its relative humidity cannot change with temperature. The 0% condition is therefore represented by the horizontal axis of the chart.

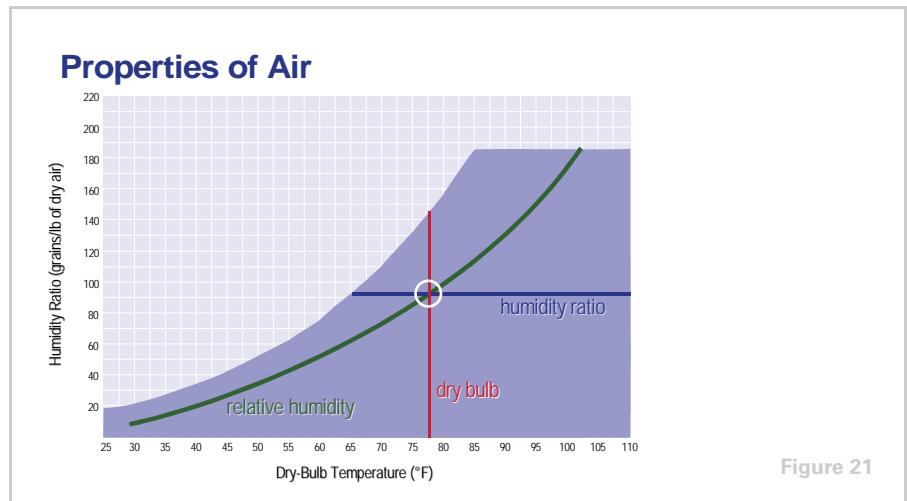

This basic chart now shows three air conditions: dry-bulb temperature (vertical lines), humidity ratio (horizontal lines) and relative humidity (diagonally curved lines).

period one
The Psychrometric Chart

notes

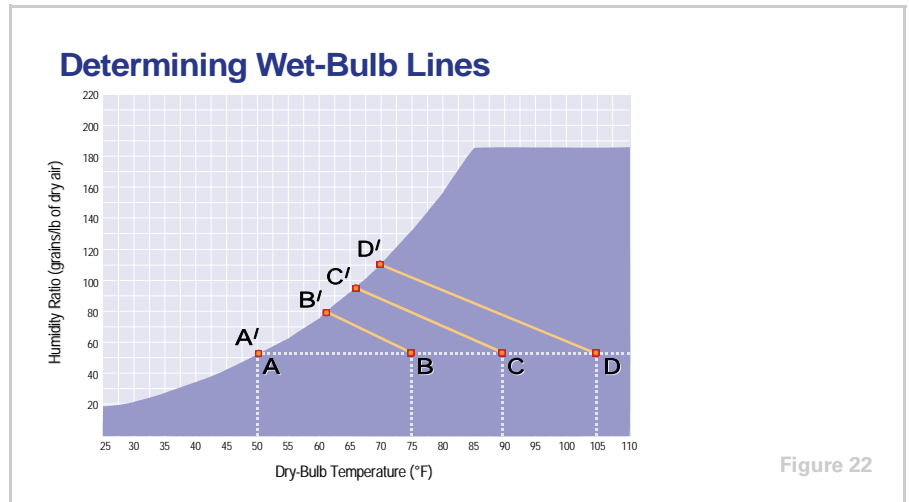

To complete this basic chart, the wet-bulb temperature lines must be added.

Once again, at a saturated condition the wet-bulb, dry-bulb and dew-point temperatures are equal. Therefore, the wet-bulb temperature lines start at the saturation curve.

To observe what happens to wet-bulb temperatures when air is heated, start with saturated air at 50°F dry bulb. At this condition, the air has a moisture content of approximately 54 grains per pound as shown by **A**. If the temperature of this air is increased to 75°F dry bulb without changing its moisture content, the air condition will move along the constant humidity ratio line (54 grains/lb) to **B**. The wet-bulb temperature of this warmed air is approximately 60.1°F.

A line drawn from **B** to a point on the saturation curve that represents 60.1°F saturation temperature (**B'**) gives an indication of the direction the wet-bulb temperature lines will run. By taking numerous wet-bulb readings under different conditions, the wet-bulb temperature lines can be added to the chart.

period one

The Psychrometric Chart

notes

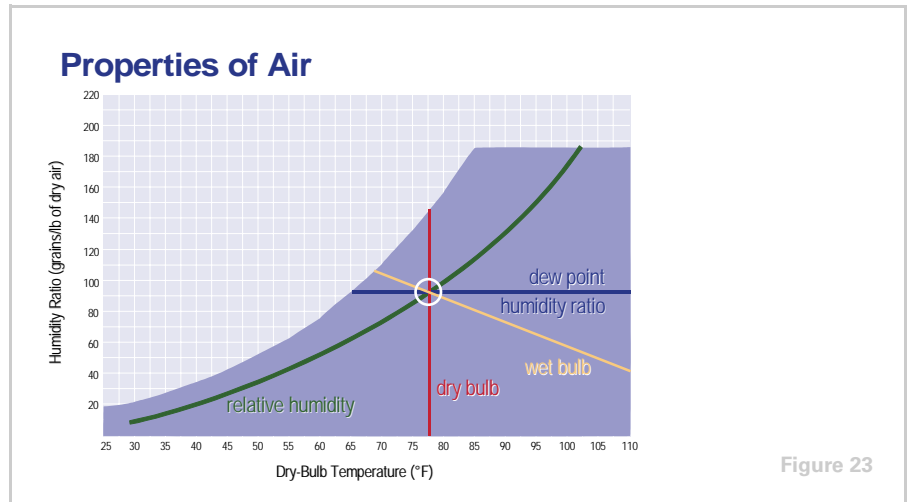

The psychrometric chart now defines these five properties of air: dry-bulb temperature (vertical lines), humidity ratio and dew-point temperature (horizontal lines), relative humidity (curved lines) and wet-bulb temperature (diagonal lines).

Remember: if any two of these five air conditions are known, the other three can be found on the psychrometric chart by locating the point of intersection of the two known conditions.

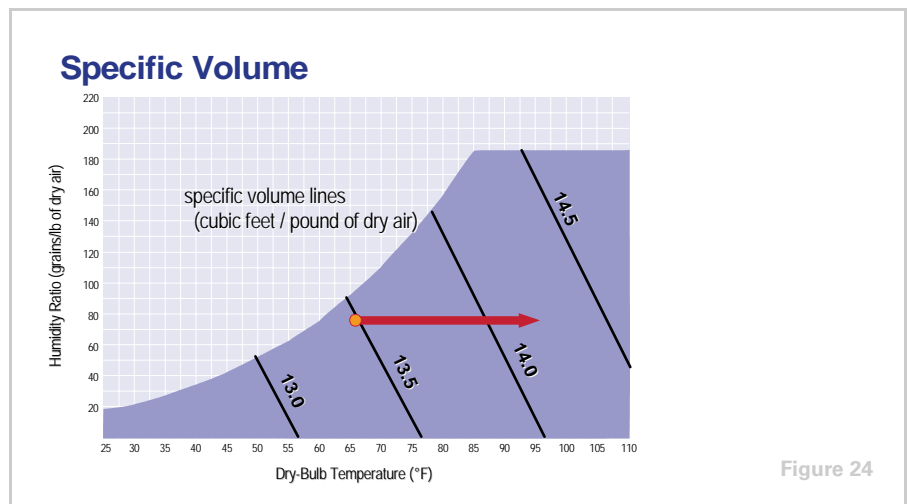

There is one more property of air that is displayed on the psychrometric chart—specific volume. **Specific volume** is defined as the volume of one pound of dry air at a specific temperature and pressure. As one pound of air is heated it occupies more space—the specific volume increases.

period one

The Psychrometric Chart

notes

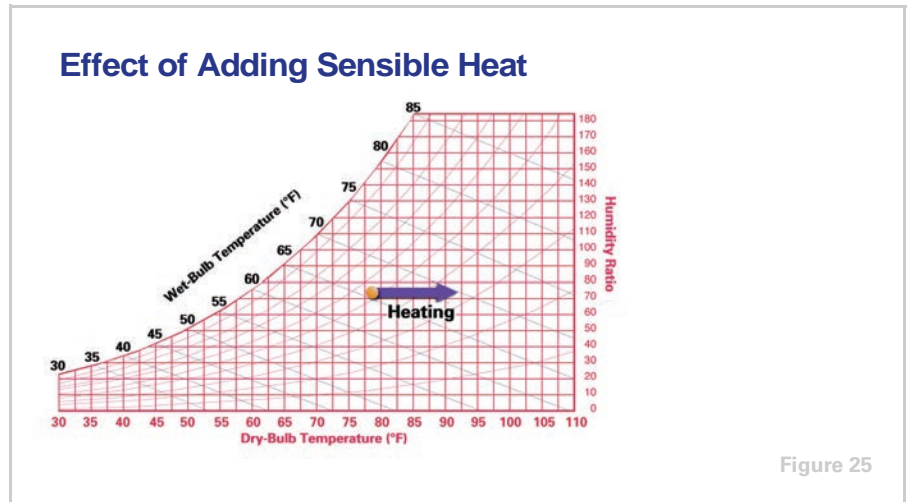

Effect of Sensible Heat and Moisture Changes

When either the sensible heat content or the moisture content of air changes, the point on the psychrometric chart that represents the original air condition moves to a position that represents the new condition of temperature and/or humidity.

For example, if sensible heat is added to air, the air condition moves horizontally to the right.

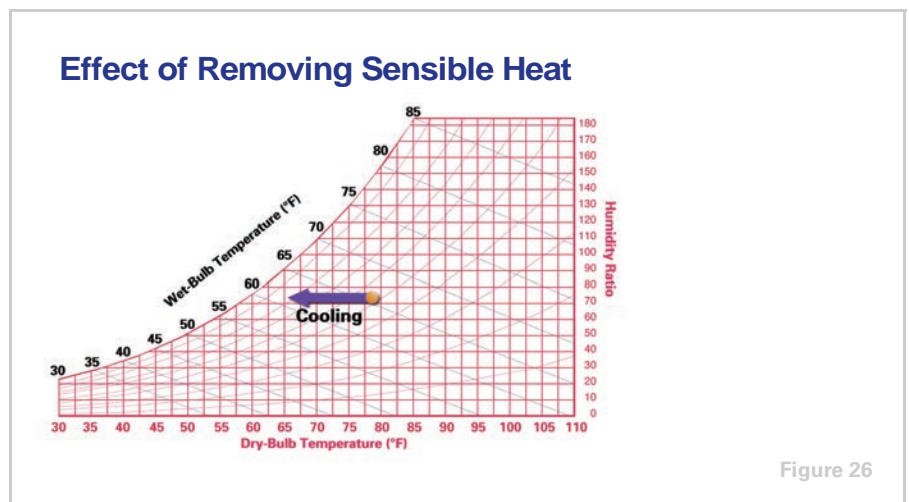

Conversely, if sensible heat is removed from air, the air condition moves horizontally to the left. As long as the moisture content of the air remains unchanged, the humidity ratio remains the same. Therefore, this movement follows the horizontal humidity-ratio lines.

period one
The Psychrometric Chart

notes

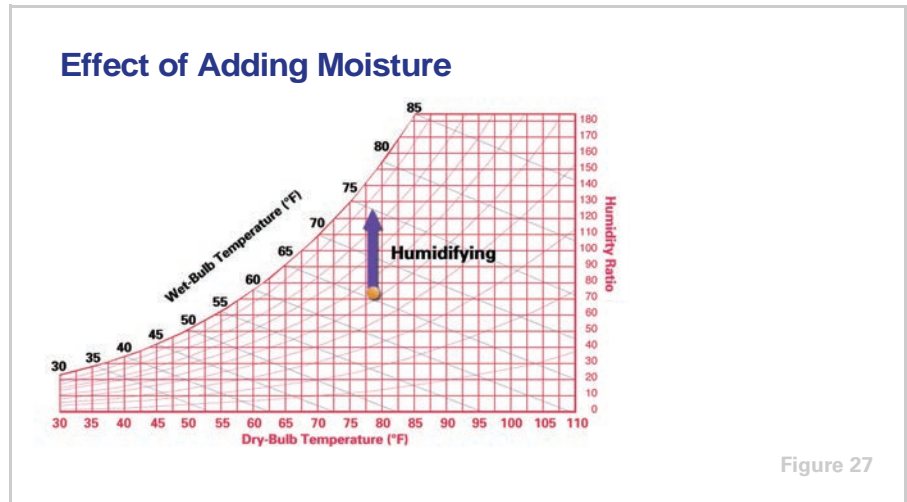

On the other hand, if moisture is added to air without changing the dry-bulb temperature, the air condition moves upward along a dry-bulb temperature line.

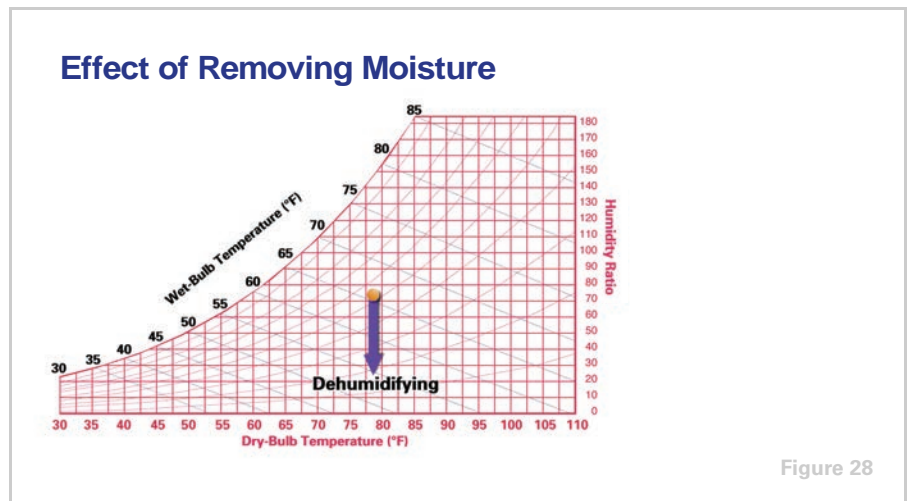

Finally, if moisture is removed from the air without changing its dry-bulb temperature, the air condition moves downward along a dry-bulb temperature line.

period one
The Psychrometric Chart

notes

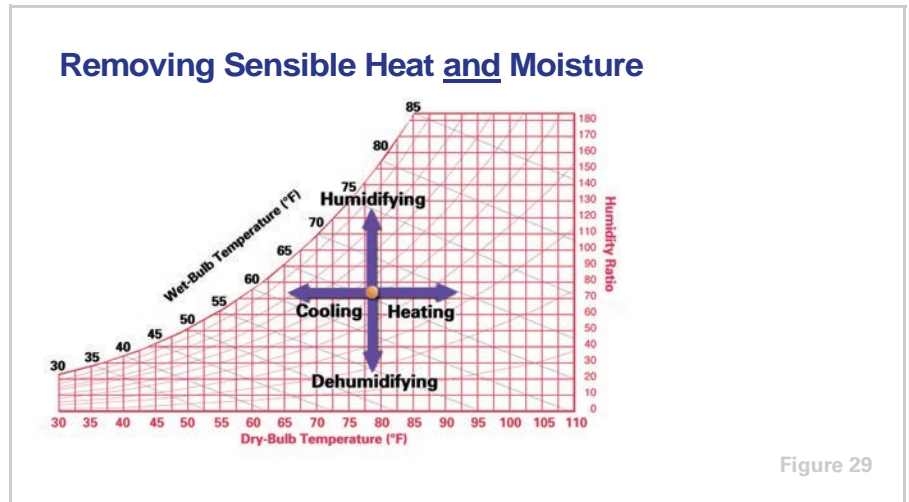

Put all of these changes together on one chart and they show the direction the air condition will move when the dry-bulb temperature or moisture content is altered.

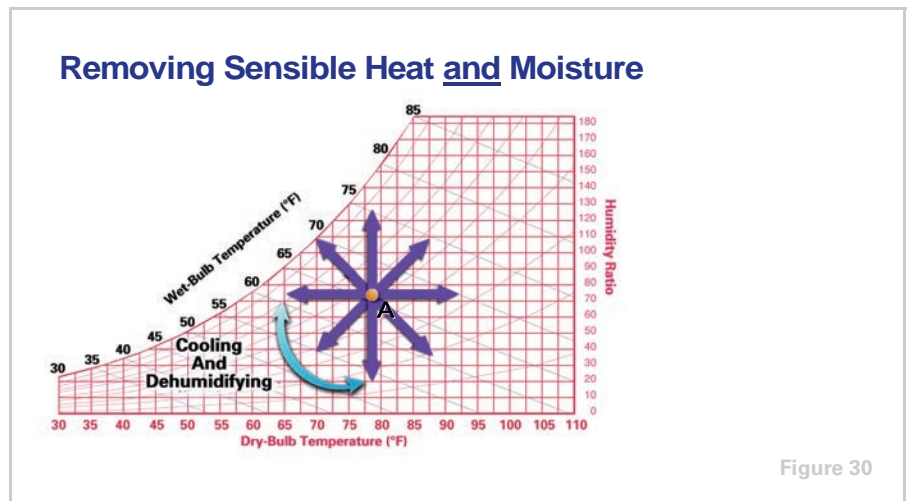

In actual practice, however, both the dry-bulb temperature and moisture content of the air generally change simultaneously. When this happens, the resulting air conditions move from **A** at some angle. The exact angle and direction depend upon the proportions of sensible and latent heat added or removed. **Sensible heat** causes a change in the air's dry-bulb temperature with no change in moisture content. **Latent heat** causes a change in the air's moisture content with no change in dry-bulb temperature.

To provide summer comfort, air is cooled and dehumidified, moving the air condition downward and to the left, resulting in a lower dry-bulb temperature and a lower moisture content.

period two

Air Mixtures

notes

Psychrometry

period two

Air Mixtures

Figure 31

Before an air conditioning problem can be analyzed on the psychrometric chart, the conditions of the air to be cooled or heated must be known.

Determining Entering Air Conditions

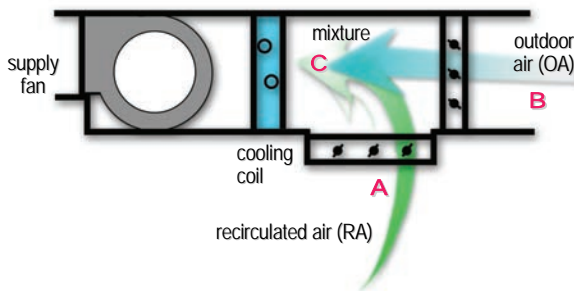

Figure 32

The air entering the cooling coil may be 100% recirculated (**A**), 100% outdoor (**B**), or a mixture of the two (**C**).

period two

Air Mixtures

notes

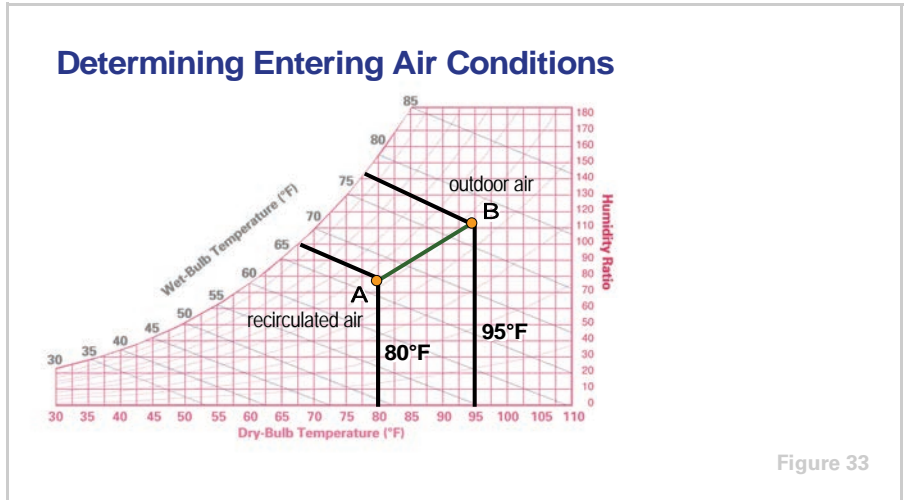

If outdoor air **B** is mixed with recirculated air **A**, the conditions of the resulting mixture are found somewhere on a straight line connecting the two points.

If the mixture is half and half, this condition falls on the midpoint of the line between **A** and **B**. If more than half of the mixture is recirculated air **A**, the condition of the mixture will fall closer to **A** than to **B**.

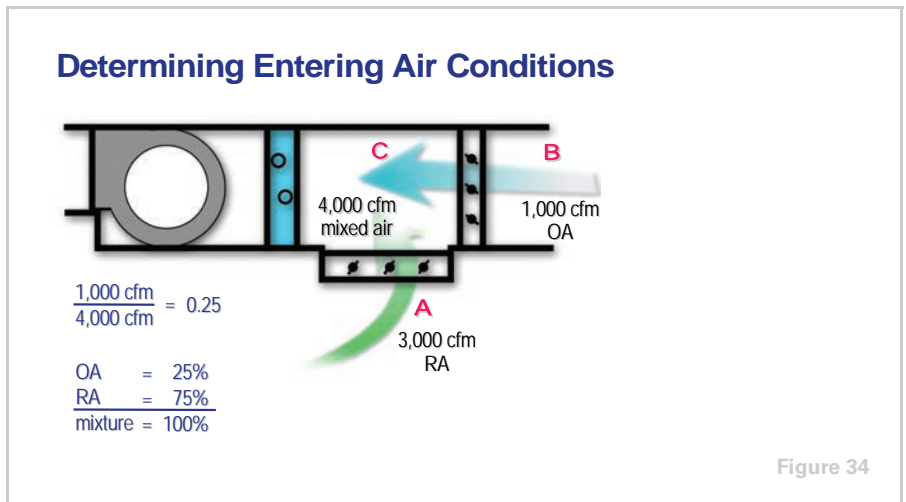

In this example, 1,000 cfm of outdoor air (OA) is mixed with 3,000 cfm of recirculated air (RA) for a total supply airflow of 4,000 cfm.

First, the percentage of outdoor air within the mixture is determined. This is done by dividing the outdoor air quantity by the total air quantity.

$$\frac{1,000 \text{ cfm}}{4,000 \text{ cfm}} = 0.25$$

period two

Air Mixtures

notes

The outdoor air quantity in this example constitutes 25% of the mixture, while the recirculated air makes up the remaining 75%.

The next step is to determine the dry-bulb temperature of the air mixture.

Determining Entering Air Conditions

$$\begin{array}{r} 95^{\circ}\text{F} \times 0.25 = 23.75^{\circ}\text{F} \\ 80^{\circ}\text{F} \times 0.75 = 60.00^{\circ}\text{F} \\ \hline \text{mixture} = 83.75^{\circ}\text{F} \end{array}$$

Figure 35

This is done by multiplying the dry-bulb temperature of each air condition by its percentage and summing the results.

For example, if the outdoor dry-bulb temperature is 95°F and it represents 25% of the air mixture, it contributes 23.75°F (or 0.25×95) to the dry-bulb temperature of the air mixture.

Similarly, if the dry-bulb temperature of the recirculated air is 80°F, it contributes 60°F (or 0.75×80) to the dry-bulb temperature of the air mixture.

The sum of 23.75°F and 60°F equals 83.75°F, the resulting dry-bulb temperature of this air mixture.

period two
Air Mixtures

notes

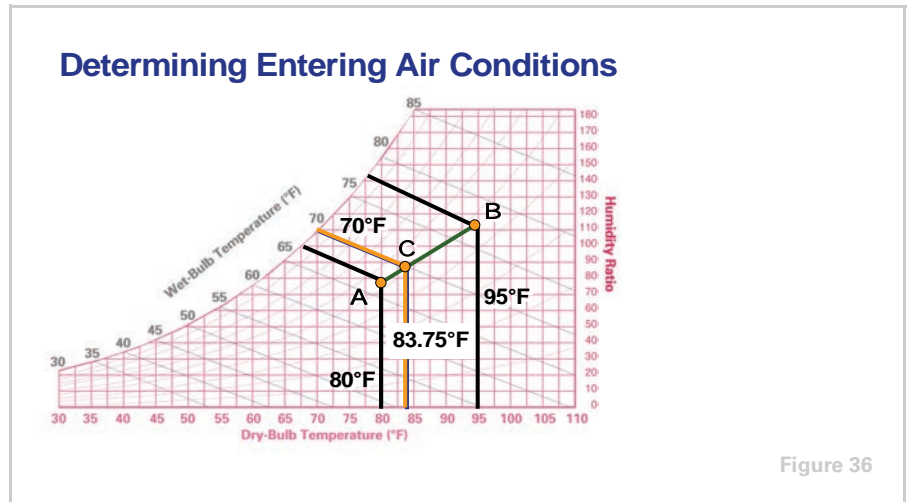

Returning to the psychrometric chart, point **C**, at which the 83.75°F dry-bulb temperature falls on the line from **A** to **B**, represents the conditions of the air mixture: 83.75°F DB and approximately 70°F WB.

Because the recirculated air quantity constitutes a larger percentage (75%) of the mixture, the mixed-air condition (**C**) is much nearer to the indoor design condition (**A**) than to the outdoor design condition (**B**).

period three

Sensible Heat Ratio

notes

Psychrometry

period three

Sensible Heat Ratio

Figure 37

This period is devoted to understanding the term **sensible heat ratio** and how it is represented on the psychrometric chart. The ratio of sensible heat gain to total heat gain is one of the most important factors affecting air conditioning system requirements.

Effect of Removing Sensible Heat

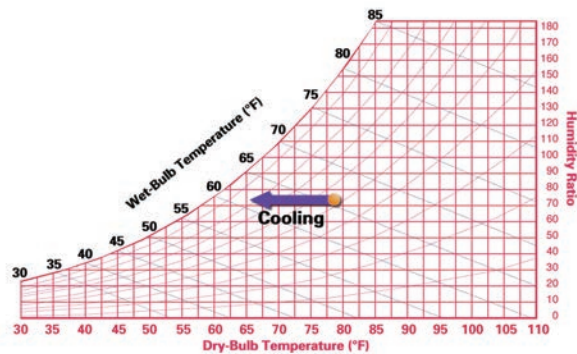
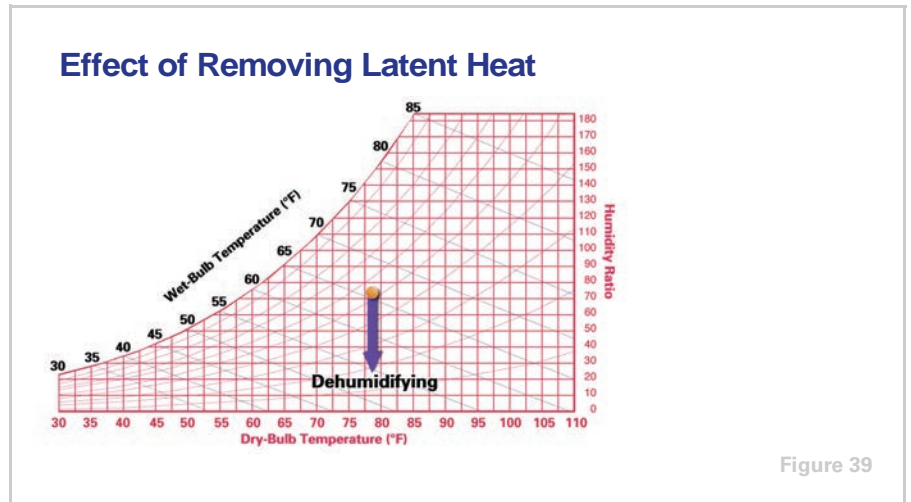

Figure 38

If only sensible heat is removed from the air, the line representing this change moves from the original condition horizontally to the left. This results in a lower dry-bulb temperature, while the moisture content (the humidity ratio) remains constant.

period three
Sensible Heat Ratio

notes



Conversely, if only latent heat is removed, the line moves vertically downward along a constant dry-bulb temperature line. This results in a lower moisture content or humidity ratio.

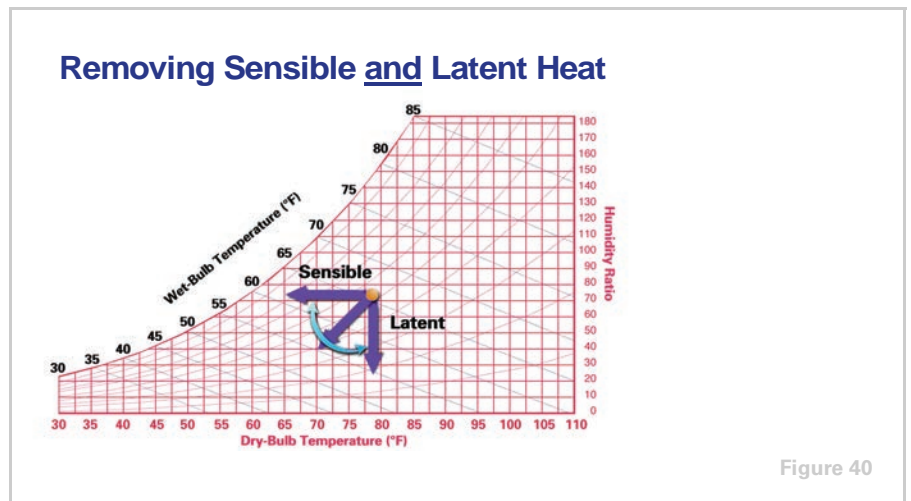

If both sensible and latent heat are removed from the air, the resulting air condition will be to the left and below the initial condition. The proportions of sensible and latent heat removed will determine the exact direction the resulting air condition follows.

period three
Sensible Heat Ratio

notes

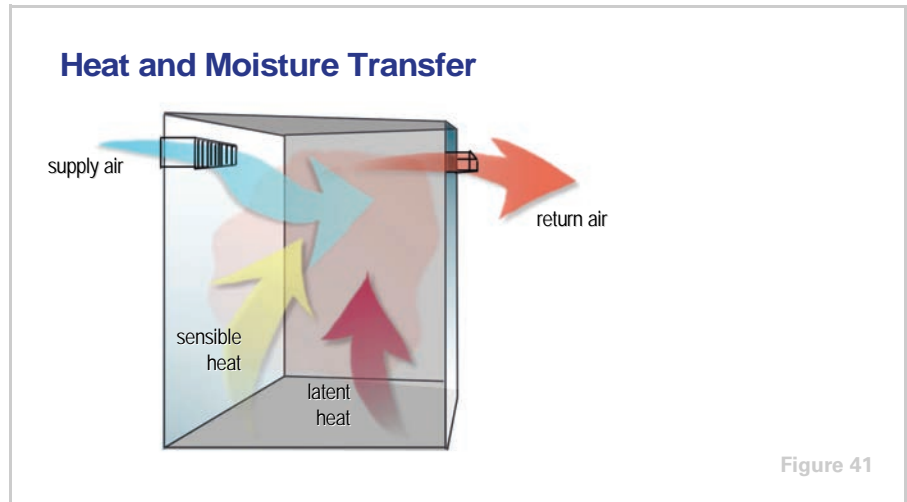

Imagine conditioned supply air as a sponge. As it enters a room, it absorbs heat and moisture. The amount of heat and moisture absorbed depends on the temperature and humidity of the supply air. This “sponge,” the supply air, must be cool enough to pick up the room's excess sensible heat gain and dry enough to pick up the room's excess latent heat (i.e. moisture).

Therefore, the excess sensible and latent heat in the room determine the required dry-bulb and wet-bulb temperatures of that supply air.

period three
Sensible Heat Ratio

notes

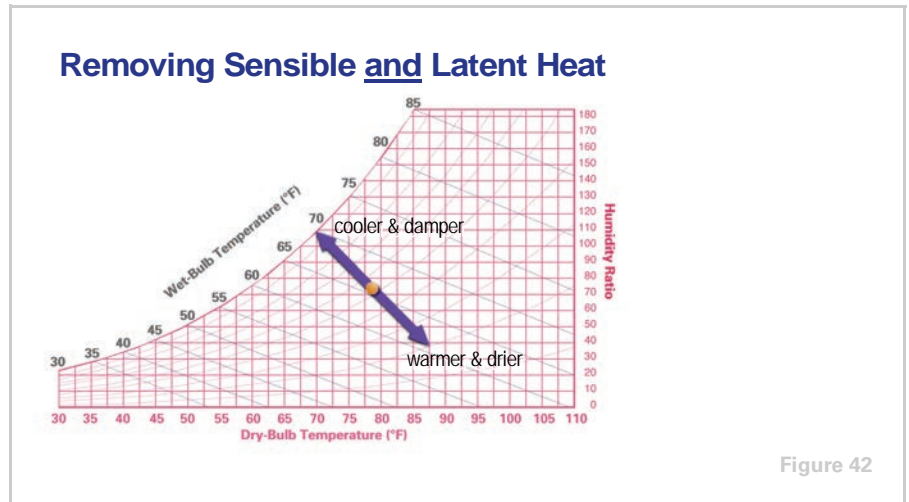

When the required amount of sensible and latent heat are not properly removed from the room, the desired room conditions cannot be maintained. For example, if too much sensible heat and not enough latent heat are removed, the room feels cold and damp. On the psychrometric chart, room conditions move up and to the left.

On the other hand, if too much latent heat but not enough sensible heat is removed, the room feels warm and dry. On the psychrometric chart, room conditions move down and to the right.

Therefore, the conditions of the supply air must be controlled accurately to ensure that both sensible and latent heat are removed in the proper proportions. There are several combinations of dry-bulb and wet-bulb temperatures that will produce the desired room conditions. Each of these combinations requires a different quantity of air.

period three
Sensible Heat Ratio

notes

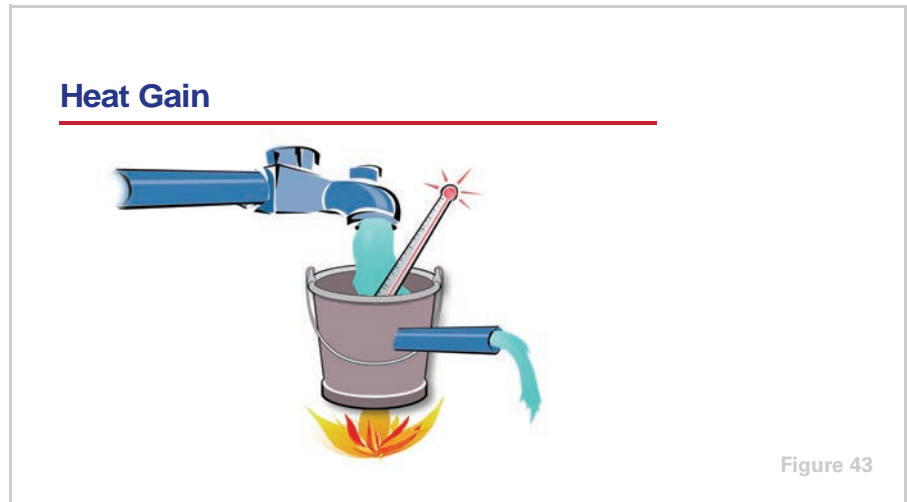

This relationship between the conditions and quantity of the supply air can be described using the analogy of maintaining a constant temperature within a container of water.

In this illustration, the container of water is capable of absorbing heat. The amount of heat it absorbs is called **heat gain**. To maintain the water temperature at a constant 75°F, any heat gain must be offset by mixing cool water with the water already in the container.

The rate at which this cool water is added to the container is determined by its temperature. For a given water temperature there is a certain flow rate — measured in gallons per minute (gpm) — that will offset the heat gain and maintain the desired temperature in the container. If the water is warm, a higher flow rate is required than if the water is very cold.

period three

Sensible Heat Ratio

notes

Sensible Heat Ratio (SHR)

$$\text{SHR} = \frac{\text{Sensible Heat Gain}}{\text{Sensible Heat Gain} + \text{Latent Heat Gain}}$$

Figure 44

The **sensible heat ratio**, abbreviated as SHR, refers to the comparison of sensible heat gain to total heat gain (sensible heat plus latent heat). Once this ratio is known, an SHR line can be drawn on the psychrometric chart.

$$\text{Sensible Heat Ratio (SHR)} = \frac{\text{Sensible Heat Gain}}{\text{Sensible Heat Gain} + \text{Latent Heat Gain}}$$

Sensible Heat Ratio Scale

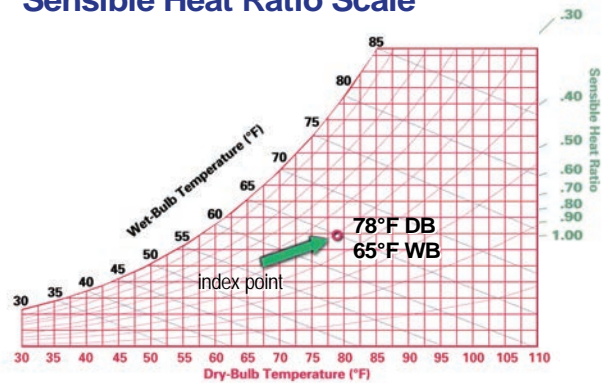

Figure 45

A scale around the right and top edges of the chart gives the SHR values. Also, there is an **index point** in the middle of the chart at the 78°F DB and 65°F WB condition.

Using a straight edge, a sensible heat ratio line can be drawn by aligning the appropriate SHR value on the scale with the index point.

period three

Sensible Heat Ratio

notes

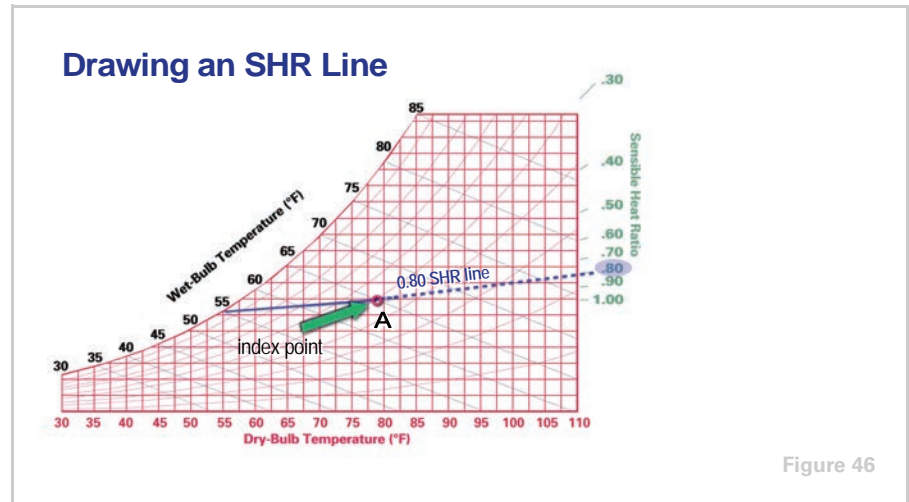

Assume that room design conditions (**A**) are 78°F DB and 65°F WB, and that the sensible heat ratio is calculated as 0.80. That is, sensible heat gain represents 80% of the total (sensible plus latent) heat gain.

The SHR line is found by aligning the index point with the 0.80 marking on the sensible-heat-ratio scale and drawing a line from the index point to the saturation curve.

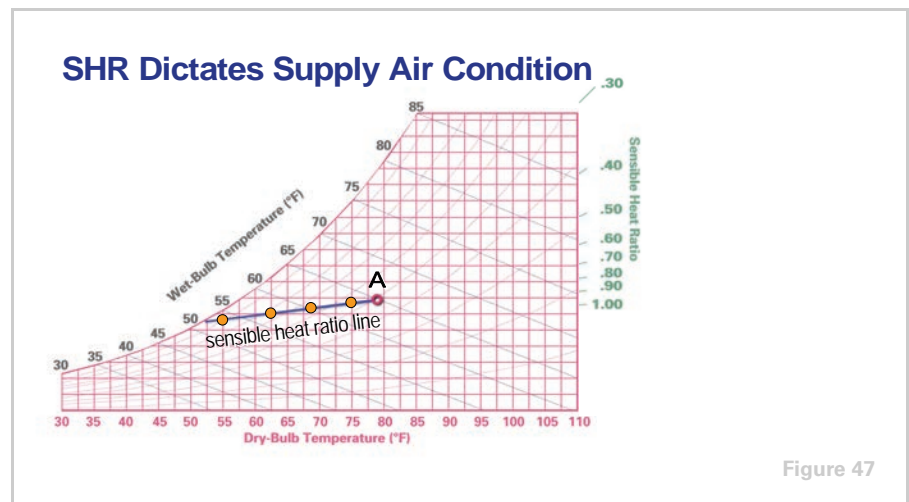

Supply air with any combination of dry-bulb and wet-bulb temperatures that falls on this line will be able to absorb the room's sensible and latent heat in the correct proportions needed to maintain the desired room conditions (**A** = 78°F DB, 65°F WB).

Each of these combinations, however, requires a different quantity of air to do the task. Recall the analogy with the container of water. If the supply air is warm, a higher quantity of air is required than if the supply air is cold.

period three
Sensible Heat Ratio

notes

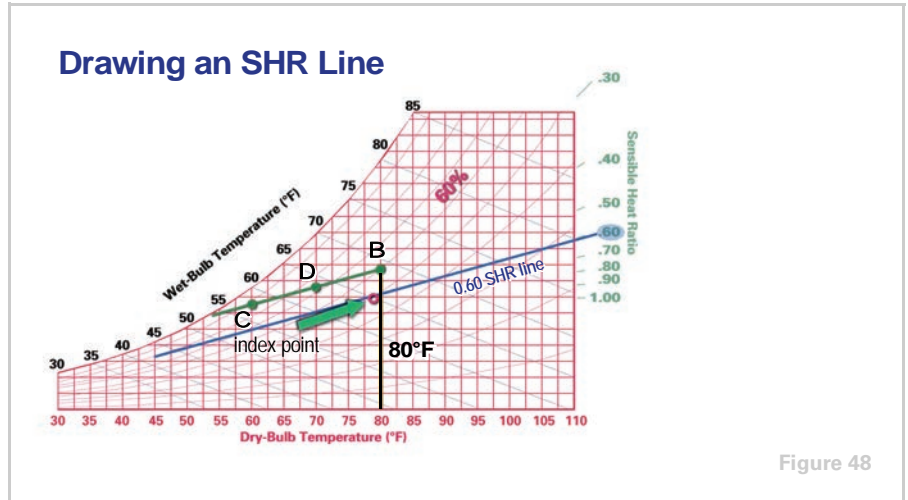

Sensible-heat-ratio lines for other conditions are drawn in the following manner. Assume that room design conditions are 80°F DB and 60% RH, and that the SHR is calculated as 0.60.

First, line up the index point with the 0.60 marking on the sensible-heat-ratio scale and draw a line. Next, draw a second line, parallel to the first, through the point **(B)** that represents the design room conditions. This is the 0.60 SHR line for a room at 80°F DB and 60% RH.

Supply air at **C** (60°F DB and 58°F WB) will maintain the desired room conditions, as will supply air at **D** (70°F DB and 64°F WB). To do so, each of these combinations will require a different quantity of air.

period four

Air Quantity

notes

Psychrometry

period four

Air Quantity

Figure 49

Next, we will determine the flow rate of supply air necessary to maintain a given set of design room conditions.

Coil Curves

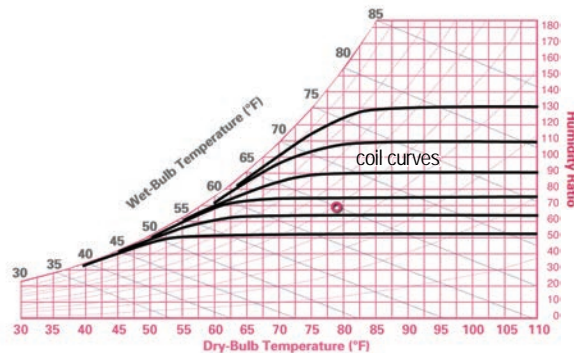

Figure 50

Before proceeding, one more set of curves on the psychrometric chart must be identified. These curved lines represent the changes in dry-bulb and wet-bulb temperatures as air passes through a “typical” cooling coil. These are commonly referred to as **coil curves**; they depict approximate coil performance. Exact coil performance depends on the actual coil geometry and can be precisely determined by coil selection software.

These curves were established from hundreds of laboratory tests of various coil geometries at different air and coolant temperatures. They let you determine leaving-coil conditions and postpone coil selection until the final design. The use of these coil curves will be discussed later.

period four

Air Quantity

notes

Determining Supply Airflow

STEP 1: Calculate the sensible heat ratio (SHR)

80,000 Btu/hr sensible heat gain

20,000 Btu/hr latent heat gain

$$\text{SHR} = \frac{80,000 \text{ Btu/hr}}{100,000 \text{ Btu/hr}} = 0.80$$

Figure 51

To demonstrate how the required supply airflow is determined, assume that a room's sensible heat gain is 80,000 Btu/hr and its latent heat gain is 20,000 Btu/hr. First, divide the sensible heat gain by the total heat gain. The resulting sensible heat ratio (SHR) is 0.80.

Determining Supply Airflow

room — 78°F DB, 50% RH

outdoor air (OA) — 95°F DB, 78°F WB

ventilation — 25% OA

Figure 52

The second step is to determine the entering air conditions. Design room air is 78°F DB, 50% RH; design outdoor air is 95°F DB, 78°F WB

Twenty-five percent (25%) outdoor air is required for ventilation purposes.

period four

Air Quantity

notes

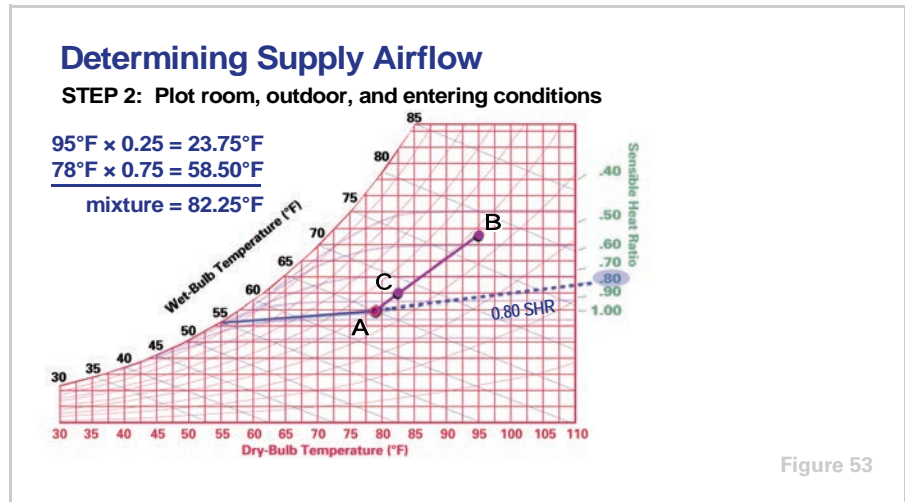

Plot the outdoor air **B** (95°F DB, 78°F WB) and indoor air **A** (78°F DB, 65°F WB) conditions on the psychrometric chart. Then calculate the mixed-air conditions using the method learned in Period 2.

$$95^{\circ}\text{F} \times 0.25 = 23.75^{\circ}\text{F}$$

$$78^{\circ}\text{F} \times 0.75 = 58.50^{\circ}\text{F}$$

$$\text{Mixed-Air Temperature} = 23.75^{\circ}\text{F} + 58.50^{\circ}\text{F} = 82.25^{\circ}\text{F}$$

Locate the mixed air conditions **C** on the psychrometric chart (82.25°F DB, 68.6°F WB).

Next, establish the SHR line by aligning the 0.80 mark on the scale with the index point and drawing a line through both points to the saturation curve. In this case, the room design conditions and the index point are the same (**A** = 78°F DB, 65°F WB).

period four
Air Quantity

notes

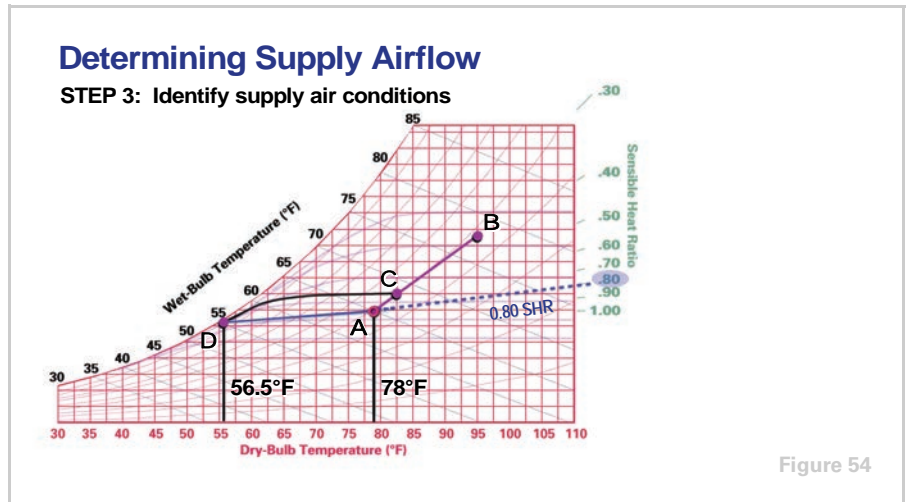

The third step is to determine the required supply air conditions. This is where the coil curves are used. Using the curvature of the nearest coil line as a guide, draw a curve from the mixed-air condition **C** until it intersects the SHR line.

Point **D**, at which this curve crosses the SHR line, represents the supply air condition that will absorb the room's sensible and latent heat in the correct proportions needed to maintain the desired room conditions. Here, this supply air condition is found to be 56.5°F DB and 55.2°F WB.

period four
Air Quantity

notes

Determining Supply Airflow

STEP 4: Solve the supply airflow equation

$$\text{Supply Airflow} = \frac{\text{Sensible Heat Gain}}{1.085 \times (\text{Room DB} - \text{Supply DB})}$$

Figure 55

With the supply air conditions known, the next step is to calculate the specific quantity of air (cfm or cubic feet per minute) needed to satisfy the room heat gains. The required supply airflow is determined using the following formula, where the sensible heat gain is expressed in Btu/hr and the two temperatures are in °F.

$$\text{Supply Airflow (cfm)} = \frac{\text{Sensible Heat Gain}}{1.085 \times (\text{Room DB} - \text{Supply DB})}$$

Realize that 1.085 is not a constant! It is the product of density, the specific heat of air and the conversion factor of 60 minutes per hour. These properties of air at “standard” conditions (69.5°F DB dry air at sea level) result in the value 1.085. Air at other conditions and elevations will cause this factor to change.

$$\begin{aligned} \text{Density} &= 0.075 \text{ lb/ft}^3 \\ \text{Specific Heat} &= 0.24 \text{ Btu/lb}^\circ\text{F} \\ 0.075 \times 0.24 \times 60 \text{ min/hr} &= 1.085 \end{aligned}$$

period four

Air Quantity

notes

Determining Supply Airflow

STEP 4: Solve the supply airflow equation

$$\frac{80,000 \text{ Btu/hr}}{1.085 \times (78^\circ\text{F} - 56.5^\circ\text{F})} = 3,430 \text{ cfm}$$

Figure 56

For this example, the supply airflow is calculated as follows:

$$\text{Supply Airflow (cfm)} = \frac{80,000 \text{ Btu/hr}}{1.085 \times (75^\circ\text{F} - 56.5^\circ\text{F})} = 3,430 \text{ cfm}$$

Determining Supply Airflow

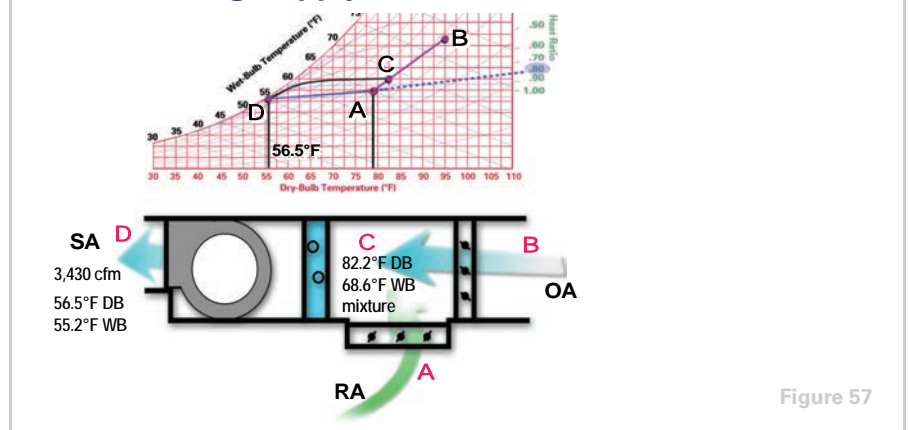

Figure 57

The cooling coil must cool and dehumidify 3,430 cfm of air from the entering condition **C** to the supply air condition **D** to maintain the desired room conditions.

period four

Air Quantity

notes

Arbitrarily Using 55°F Supply Air

47,000 Btu/hr sensible heat gain
20,000 Btu/hr latent heat gain

$$\text{SHR} = \frac{47,000 \text{ Btu/hr}}{67,000 \text{ Btu/hr}} = 0.70$$

Figure 58

Some designers prefer to set the supply air temperature at 55°F or use a 20°F temperature differential (Room DB – Supply DB) without regard for the actual sensible heat ratio of the room.

Using our same example, let's examine how this has the potential for creating a problem. Assume that the building design changes to use a much-higher-quality glass that will reduce the sensible portion of the design load from 80,000 Btu/hr to 47,000 Btu/hr. This reduces the SHR to 0.70.

Arbitrarily Using 55°F Supply Air

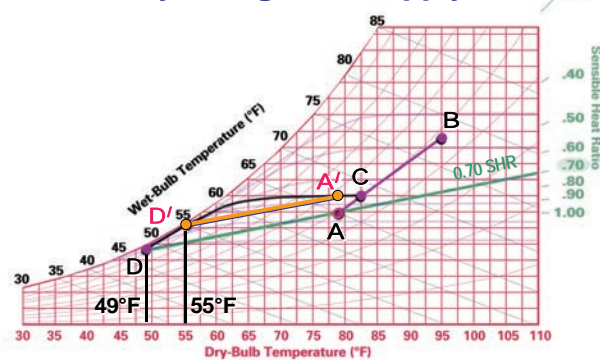

Figure 59

Plotting this new SHR line on the psychrometric chart, we find that the SHR line crosses the coil curve at approximately 49°F DB (**D**).

If the system is arbitrarily designed with a 55°F supply air temperature **D'**, the resulting room conditions will fall on the 0.70 SHR line drawn through **D'**. The resulting room conditions **A'** will be 78°F DB, 57% RH. This arbitrary design practice results in a higher room relative humidity than desired.

period five
Tons of Refrigeration

notes

Psychrometry

period five

Tons of Refrigeration

Figure 60

The psychrometric chart can also be used to determine the total load on the refrigeration equipment, expressed in Btu per hour or **tons of refrigeration**. One ton equals 12,000 Btu/hr.

What is Enthalpy?

The total heat energy in one pound of air (Btu/lb) at its present condition.

Enthalpy (h) = Sensible Heat + Latent Heat

Figure 61

Another property of air, enthalpy, must now be defined. **Enthalpy** describes the total amount of heat energy, both sensible and latent, in one pound of air at its present condition. It is expressed in Btu per pound of dry air (Btu/lb). When displayed in formulas, enthalpy is usually designated as h .

period five
Tons of Refrigeration

notes

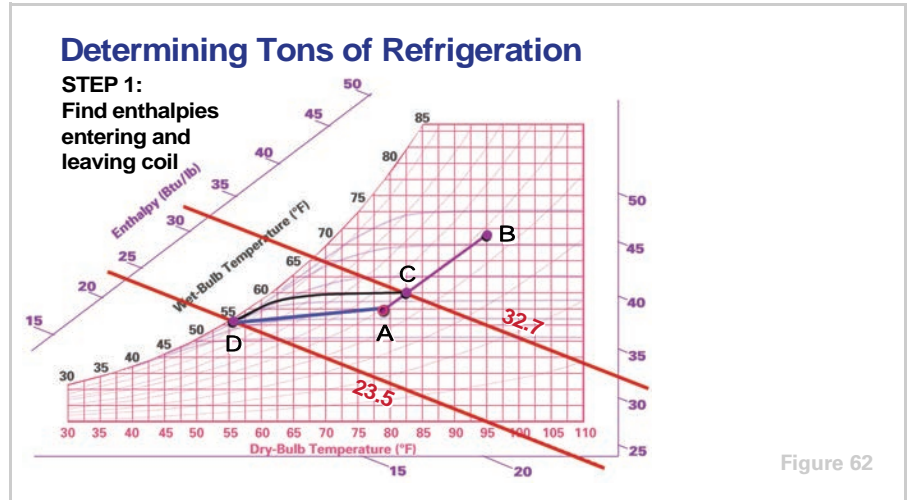

Using the previous example for calculating supply airflow, the first step is to determine the enthalpies of the air entering and leaving the cooling coil. This is accomplished by lining up three points on the chart, including the entering-air condition and identical points on the two enthalpy scales — one each on the left and right edges of the psychrometric chart.

Using this method, the enthalpy of the mixed air entering the coil **C** is found to be 32.7 Btu/lb. Similarly, the enthalpy of the supply air leaving the coil **D** is found to be 23.5 Btu/lb.

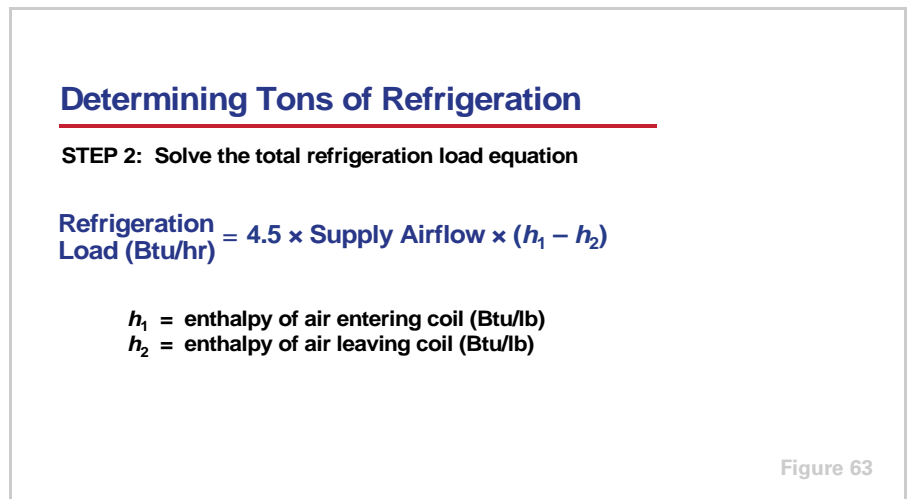

The total refrigeration load, in terms of Btu per hour, is then calculated using the following formula, where the supply airflow is expressed in cfm, h_1 is the entering-air enthalpy in Btu/lb, and h_2 is the leaving-air enthalpy in Btu/lb.

$$\text{Refrigeration Load (Btu/hr)} = 4.5 \times \text{Supply Airflow} \times (h_1 - h_2)$$

period five

Tons of Refrigeration

notes

Realize that 4.5 is not a constant! It is the product of density of air and the conversion factor of 60 minutes per hour. The density of air at “standard” conditions (69.5°F DB dry air at sea level) results in the value 4.5. Air at other conditions and elevations will cause this factor to change.

$$\begin{aligned} \text{Density} &= 0.075 \text{ lb/ft}^3 \\ 0.075 \times 60 \text{ min/hr} &= 4.5 \end{aligned}$$

Determining Tons of Refrigeration

STEP 2: Solve the total refrigeration load equation

$$4.5 \times 3,430 \text{ cfm} \times (32.7 - 23.5) = 142,000 \text{ Btu/hr}$$

$$\frac{142,000 \text{ Btu/hr}}{12,000 \text{ Btu/hr/ton}} = 11.8 \text{ tons of refrigeration}$$

Figure 64

Using the supply airflow calculated during Period 4 and the enthalpy values read from the psychrometric chart:

$$\text{Refrigeration Load (Btu/hr)} = 4.5 \times 3,430 \text{ cfm} \times (32.7 - 23.5) = 142,000 \text{ Btu/hr}$$

Converting to the more common units of tons:

$$\frac{142,000 \text{ Btu/hr}}{12,000 \text{ Btu/hr/ton}} = 11.8 \text{ tons of refrigeration}$$

period five
Tons of Refrigeration

notes

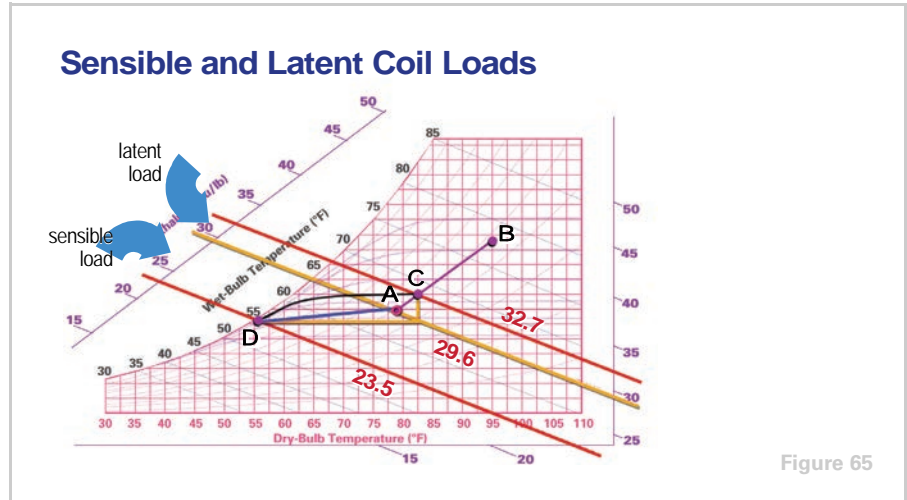

The psychrometric chart can also be used to determine the sensible and latent components of the coil's refrigeration load.

First, draw a right triangle through the coil entering and leaving air conditions. The vertical leg represents the amount of moisture removed by the coil, i.e., latent load, and the horizontal leg represents the amount of change in dry-bulb temperature through the coil, i.e., sensible load.

period five
Tons of Refrigeration

notes

Sensible and Latent Coil Loads

$$4.5 \times 3,430 \text{ cfm} \times (29.6 - 23.5) = 94,150 \text{ Btu/hr}$$

7.8 tons of refrigeration (sensible)

$$4.5 \times 3,430 \text{ cfm} \times (32.7 - 29.6) = 47,850 \text{ Btu/hr}$$

4.0 tons of refrigeration (latent)

Figure 66

By determining the enthalpy values for these three points, the same equation can be used to calculate both the sensible and the latent portions of the coil's refrigeration load.

$$\text{Sensible Refrigeration Load} = 4.5 \times 3,430 \text{ cfm} \times (29.6 - 23.5) = 94,150 \text{ Btu/hr}$$

$$\frac{94,150 \text{ Btu/hr}}{12,000 \text{ Btu/hr/ton}} = 7.8 \text{ tons of refrigeration (sensible)}$$

$$\text{Latent Refrigeration Load} = 4.5 \times 3,430 \text{ cfm} \times (32.7 - 29.6) = 47,850 \text{ Btu/hr}$$

$$\frac{47,850 \text{ Btu/hr}}{12,000 \text{ Btu/hr/ton}} = 4.0 \text{ tons of refrigeration (latent)}$$

period six

Psychrometric Analyses

notes

Psychrometry

period six

Psychrometric Analyses

Figure 67

Now we will look at a few ways that the psychrometric chart can help us analyze air conditioning systems. For simplicity, we will limit our examples to systems serving a single zone.

SHR at Full-Load Conditions

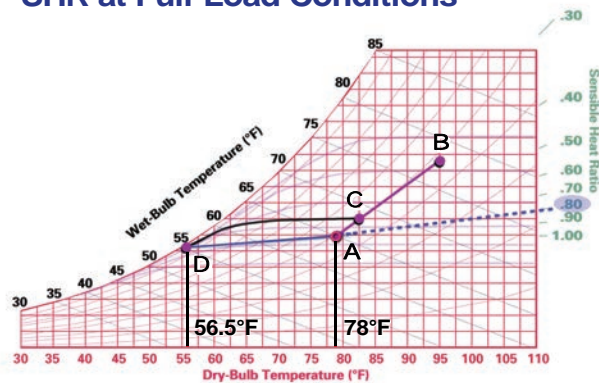

Figure 68

In the previous example, the sensible heat ratio was based on **full load or design load conditions**. It must be understood that the sensible portion of total heat gain is particularly subject to change throughout the day, causing the ratio of sensible to total heat gain to change.

period six

Psychrometric Analyses

notes

SHR Changes with Room Load

Full-Load SHR:

$$\frac{80,000 \text{ Btu/hr}}{80,000 \text{ Btu/hr} + 20,000 \text{ Btu/hr}} = 0.80$$

Part-Load SHR:

$$\frac{47,000 \text{ Btu/hr}}{47,000 \text{ Btu/hr} + 20,000 \text{ Btu/hr}} = 0.70$$

Figure 69

For example, assume that at full load the room is subject to an 80,000 Btu/hr sensible heat gain and a 20,000 Btu/hr latent heat gain. The full-load sensible heat ratio is 0.80.

At other times during the day, clouds block the sun and reduce the solar heat gain, and some of the lights are turned off. This reduces the room's sensible heat gain from 80,000 Btu/hr to 47,000 Btu/hr. The room's latent heat gain originates primarily from people. Assuming that the occupancy of the room remains constant, the latent heat gain is still 20,000 Btu/hr and the part-load sensible heat ratio becomes 0.70.

SHR at Part-Load Conditions

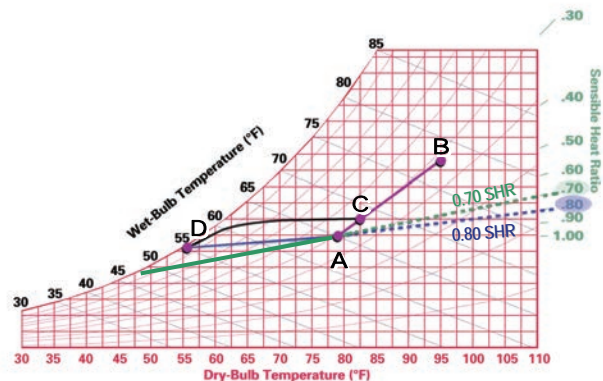

Figure 70

To maintain the design room conditions **A** for this part-load sensible heat ratio, a different supply air condition — one that falls on the 0.70 SHR line — and a different airflow are required. But suppose the system in this example was designed to deliver a constant quantity of air and vary its supply temperature to meet the changing loads.

period six

Psychrometric Analyses

notes

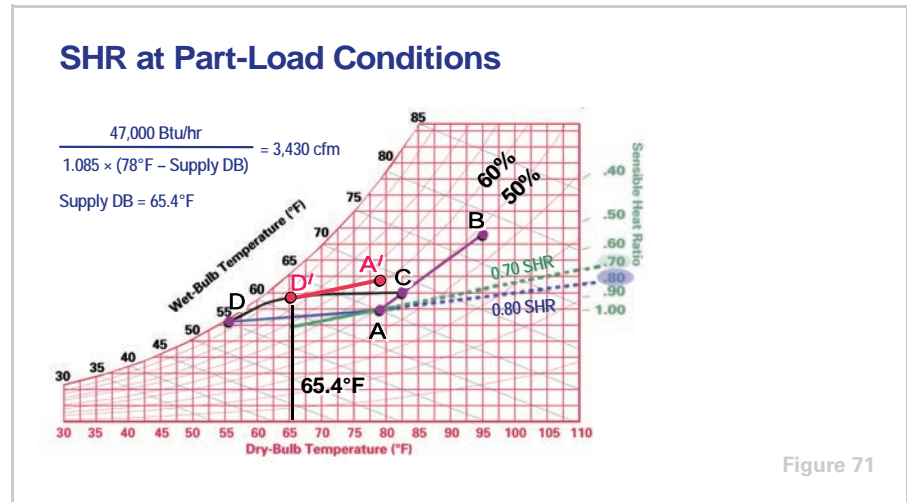

In response to the reduction in room sensible heat gain, the coil capacity is throttled, raising the supply air temperature from **D** to **D'** to balance the new room sensible heat gain. This new supply air temperature is dictated by the equation:

$$\text{Supply Airflow (cfm)} = \frac{\text{Sensible Heat Gain}}{1.085 \times (\text{Room DB} - \text{Supply DB})}$$

Since the supply airflow and the desired room dry-bulb temperature are constant, the only variable that responded to this change in sensible heat gain is supply air temperature.

$$\frac{47,000 \text{ Btu.hr}}{1.085 \times (78^\circ\text{F} - \text{Supply DB})} = 3,430 \text{ cfm}$$

$$\text{Supply DB} = 65.4^\circ\text{F}$$

This new supply air temperature **D'** is delivered in sufficient quantity to absorb the room's sensible heat gain, but it does not fall on the part-load SHR line and is not dry enough to completely absorb the latent heat gain. When the conditioned air enters the room, it mixes with room air along the 0.70 sensible heat ratio line from **D'** to **A'**. The resulting room condition **A'**, where the SHR line intersects the room dry-bulb temperature line (78°F), shows that the relative humidity increased to 61%.

period six

Psychrometric Analyses

notes

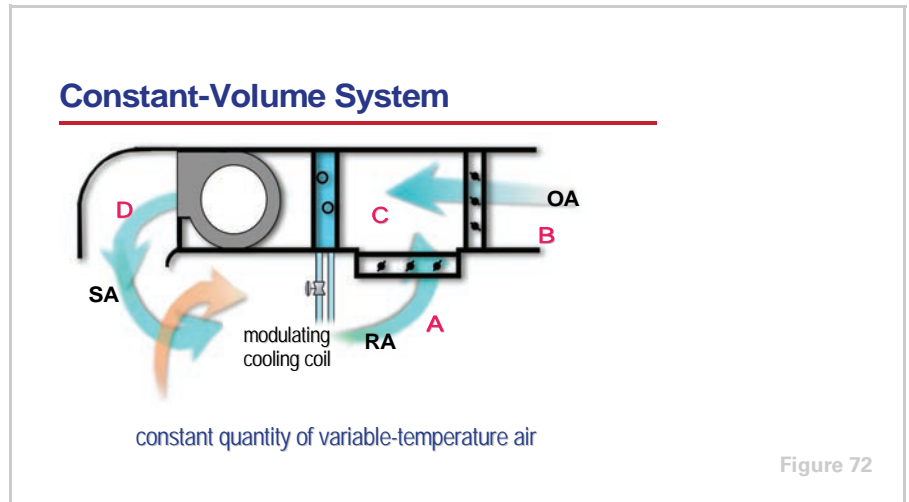

This is the manner in which a constant-volume, variable-temperature system with a modulating coil performs. It provides a constant quantity of air to the room and responds to part-load conditions by varying the supply air temperature. This is performed by modulating the flow of the cooling fluid through the coil, typically using a 2-way or 3-way control valve controlled by a thermostat that senses the room dry-bulb temperature. Such a system can provide good dry-bulb temperature control. As the sensible heat ratio changes from full load, however, it may lose control of the room relative humidity.

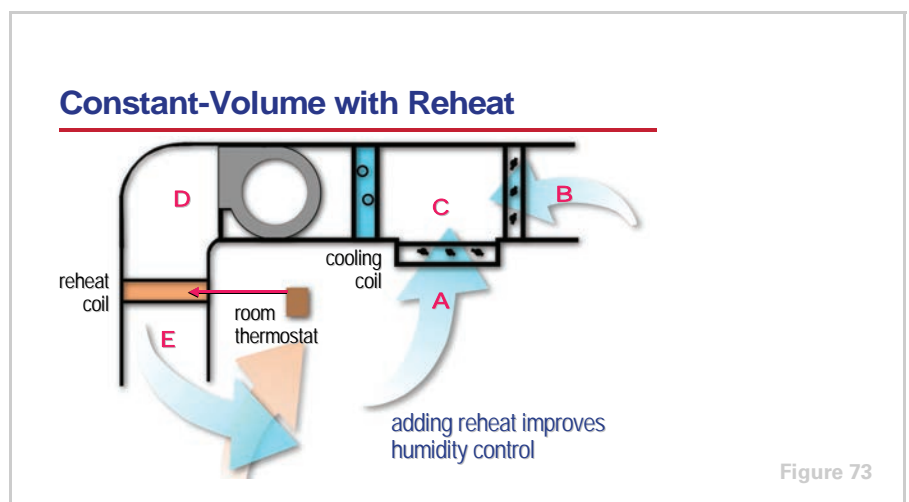

One method of improving the constant-volume system's ability to control room humidity is to reheat the supply air. In this example, reheat is provided by a heating coil located downstream of the air handler. This reheat coil is controlled by a thermostat sensing the room dry-bulb temperature, while the cooling coil is controlled to provide a constant leaving-air temperature.

period six

Psychrometric Analyses

notes

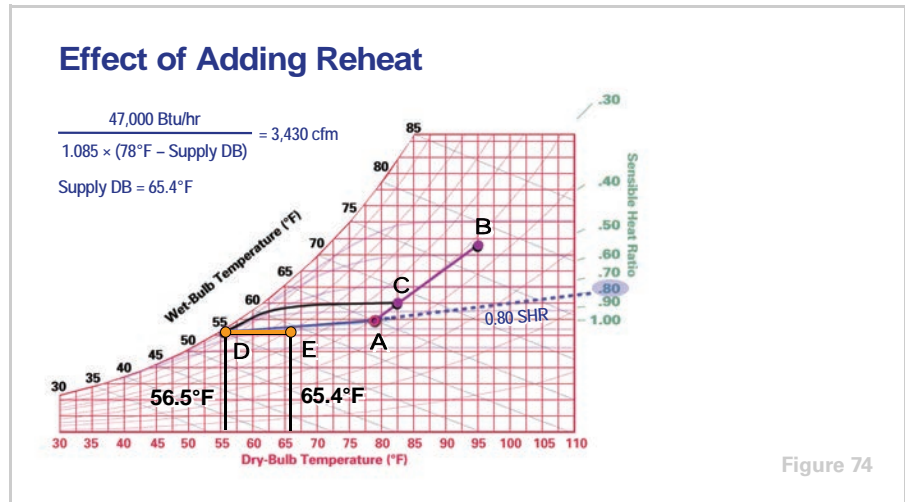

Using the part-load conditions from the previous example, the room's sensible heat gain is reduced from 80,000 Btu/hr to 47,000 Btu/hr while the latent heat gain remains the same.

Sensing the reduction in dry-bulb temperature due to the lower sensible heat gain, the room thermostat assumes control of the reheat coil. The cooling coil is controlled to provide a constant supply air temperature (**D** = 56.5°F DB), while the reheat coil is controlled to add just enough heat to the supply air to offset the reduction in room sensible-heat gain.

Since the supply airflow is constant and the desired room dry-bulb temperature and sensible heat gain are known, we can calculate the required "re-heated" supply air temperature.

$$\frac{47,000 \text{ Btu/hr}}{1.085 \times (78^\circ\text{F} - \text{Supply DB})} = 3,430 \text{ cfm}$$

$$\text{Supply DB} = 65.4^\circ\text{F}$$

Since the supply air leaving the coil is sensibly heated (i.e. no moisture is added or removed), it moves horizontally along a constant humidity-ratio line from **D** to **E**. The resulting supply air conditions are 65.4°F DB, 58.9°F WB.

period six

Psychrometric Analyses

notes

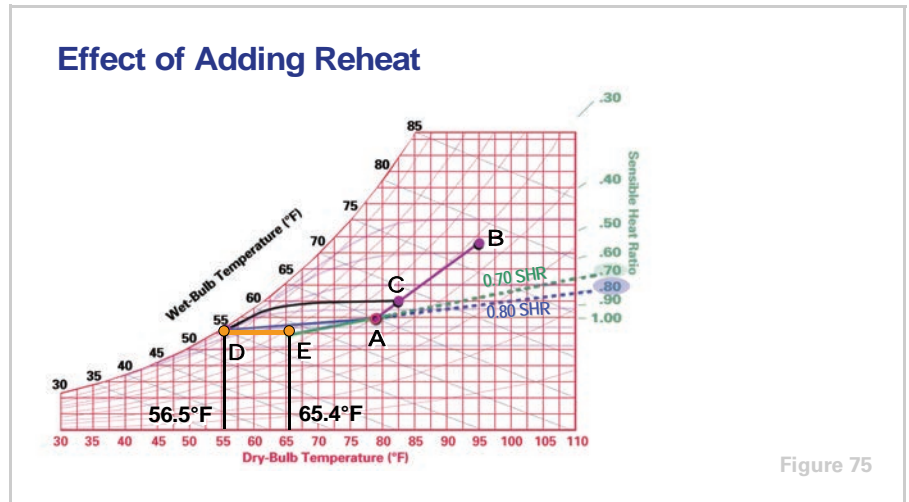

This supply air mixes with room air along the part-load 0.70 SHR line from **E** to **A**, arriving at the desired room conditions **A**. Now, if the room's latent heat gain were also changed, the resulting room conditions would not fall exactly on **A**, but on the appropriate SHR line that runs through **E**.

Adding reheat permits better room humidity control at various part-load conditions while maintaining room dry-bulb temperature control. Realize, however, that this system uses more energy than the previous constant-volume system with a modulating cooling coil: it constantly cools the supply air to 56.5°F, then reheats the air as necessary when the building sensible load drops.

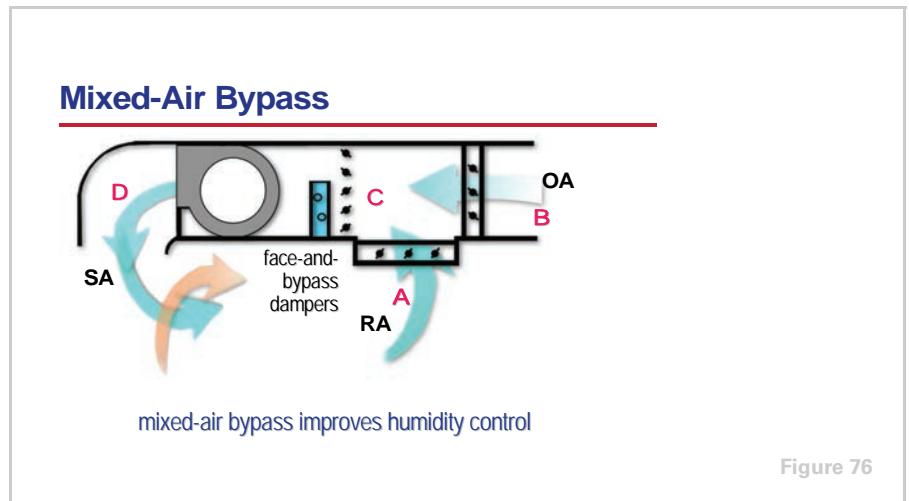

Another method of improving the constant-volume system's ability to control room humidity is to bypass mixed air around the cooling coil. In this example, face-and-bypass dampers are placed in front of the cooling coil and used to vary the portion of the supply air that actually passes through the coil, thus

period six

Psychrometric Analyses

notes

varying the supply air temperature as the two airstreams mix downstream of the air handler.

The face-and-bypass dampers are controlled by the room dry-bulb thermostat. The cooling coil is allowed to “run wild,” causing the air that does pass through it to be cooled more at partial airflows.

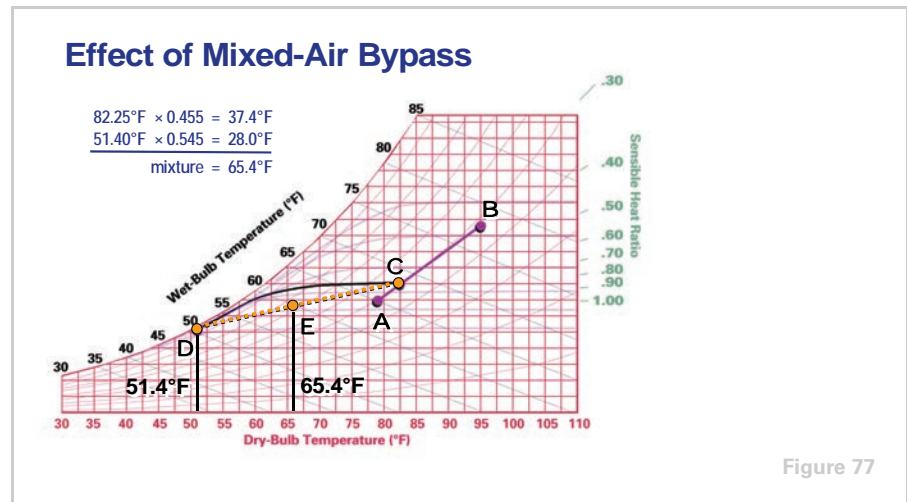

At our example part-load conditions, the room thermostat assumes control of the face-and-bypass dampers, which reduces the amount of air passing through the cooling coil. Since the coil is now “running wild,” the reduced airflow through the coil (1,870 cfm) is cooled and dehumidified more than at full load (**D**). When the conditioned air mixes with the bypass air (1,560 cfm), the required supply air condition (3,430 cfm at **E**) results.

period six
Psychrometric Analyses

notes

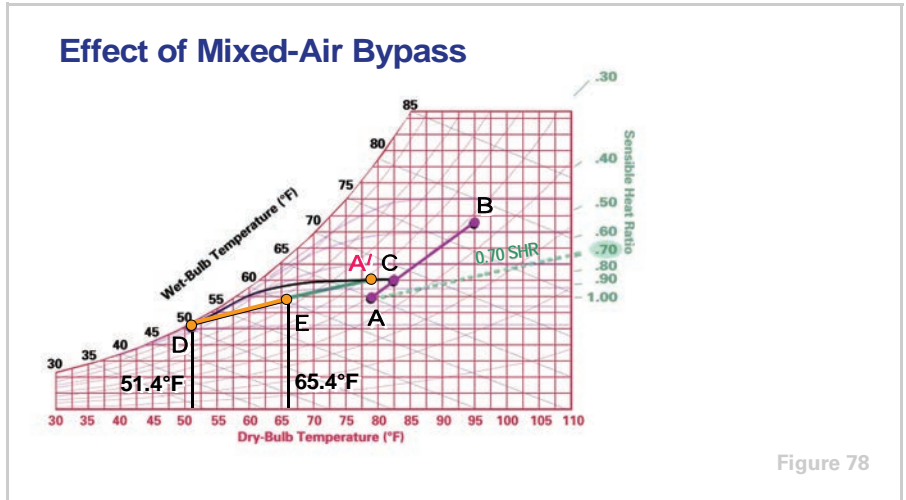

This supply air **E** mixes with room air along the part-load 0.70 SHR line, arriving at the resulting new room conditions **A'**. While the quantity and temperature of supply air are suitable to absorb the room's sensible heat gain, they are unable to completely absorb the latent heat gain. The result is a shift in room conditions from the design point **A** to 78°F DB, 58% RH (**A'**).

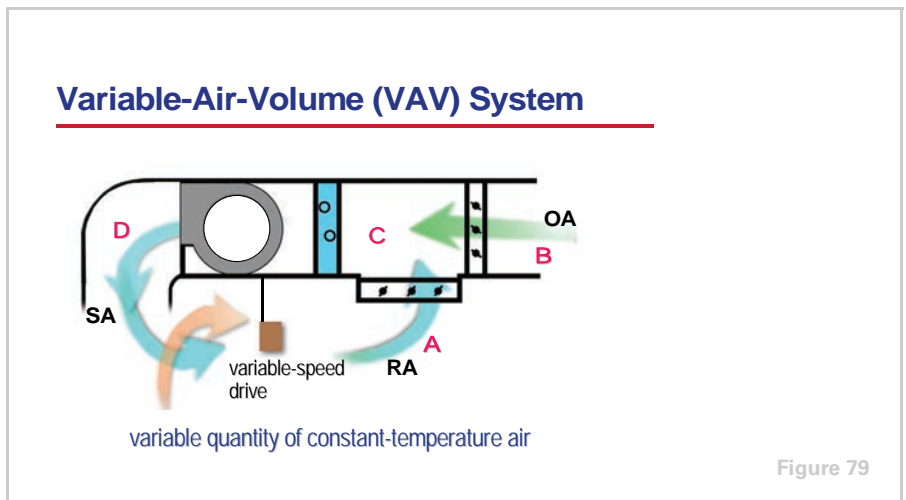

The final method of part-load control we will analyze is to vary the supply airflow to the room.

Let's look at the same example again, this time using a simple variable-air-volume (VAV) system. This system responds to part-load conditions by supplying a variable quantity of constant-temperature air. At full load, this system looks the same on the psychrometric chart as the constant-volume system — it supplies 3,430 cfm of 56.5°F air to the room.

period six

Psychrometric Analyses

notes

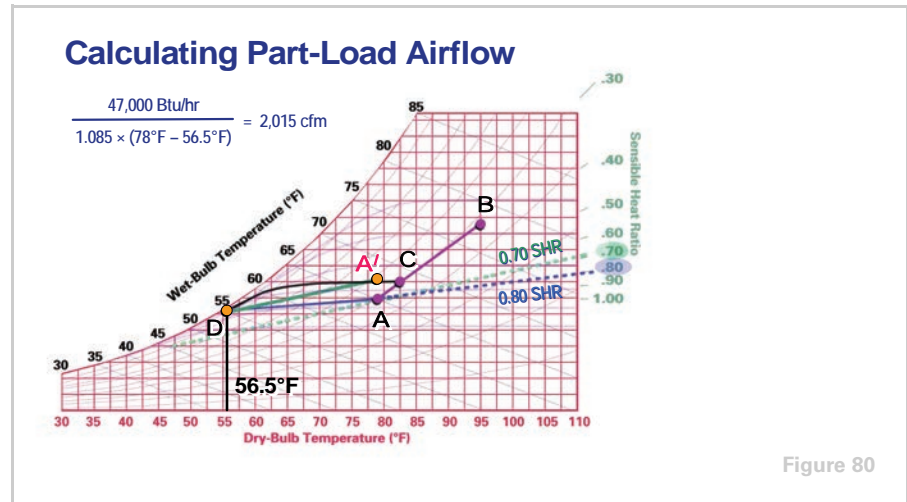

At part load, when the SHR of the room is reduced from 0.80 to 0.70, the VAV system responds by reducing the quantity of 56.5°F air supplied to the room to match the reduced sensible heat gain. The part-load sensible heat gain of 47,000 Btu/hr and the constant supply air temperature, 56.5°F DB, are used to determine the required part-load air quantity.

$$\text{Supply Airflow (cfm)} = \frac{47,000 \text{ Btu/hr}}{1.085 \times (78^\circ\text{F} - 56.5^\circ\text{F})} = 2,015 \text{ cfm}$$

When the conditioned supply air **D** enters the room, it mixes with room air along the part load SHR line from **D** to **A'**. This quantity and temperature of supply air are suitable to absorb the room's sensible heat gain, but are unable to completely absorb the latent heat gain. The result is a shift in the room conditions from the design point **A** to 78°F DB and 59% RH (**A'**). While the simple VAV system does a better job of controlling room humidity than the simple constant-volume system, it is still unable to maintain the desired condition of 50% RH.

To more accurately determine the final room conditions, you would cycle through the psychrometric chart again. First, use the new room condition **A'** to calculate the mixed-air entering conditions. Then use the coil curves to find the condition of the 56.5°F dry-bulb supply air. Finally, draw the SHR line through this new supply air condition to find the resulting room conditions. Repeating this process a few times allows the room condition to converge and be equal to the condition used in the previous iteration.

period six

Psychrometric Analyses

notes



The psychrometric chart is a visual tool that helps designers find solutions to many common HVAC problems by plotting conditions on the chart.

Today, many of these same problems can be quickly solved by computers, which can often eliminate the need for a graphical solution altogether. Still, a basic understanding of psychrometric principles is required to use these tools, and is fundamental to the science of air conditioning.

Instead of relying solely on the “typical” coil curves printed on the psychrometric chart, many manufacturers provide computerized coil selection programs to determine the actual performance of specific coils. Software tools are also available to assist you in performing psychrometric calculations, such as determining the properties of air at a given set of conditions, and finding the conditions that result when two air streams are mixed.

period seven Review

notes

Psychrometry

period seven

Review

Figure 82

Let's review some of the main concepts from this clinic on psychrometry.

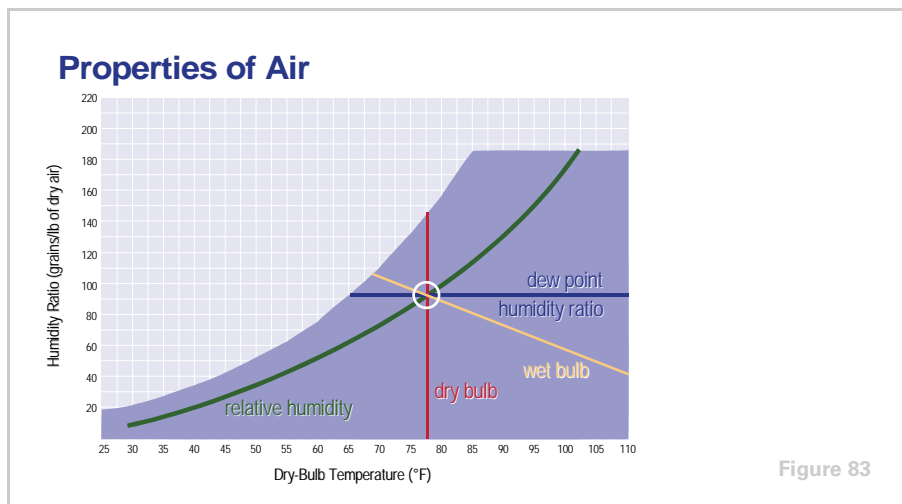

Figure 83

The lines of the psychrometric chart represent five physical properties of air: **dry bulb**, **wet bulb**, **dew point**, **humidity ratio**, and **relative humidity**. If any two of these properties are known, the remaining properties can be determined from the chart.

period seven

Review

notes

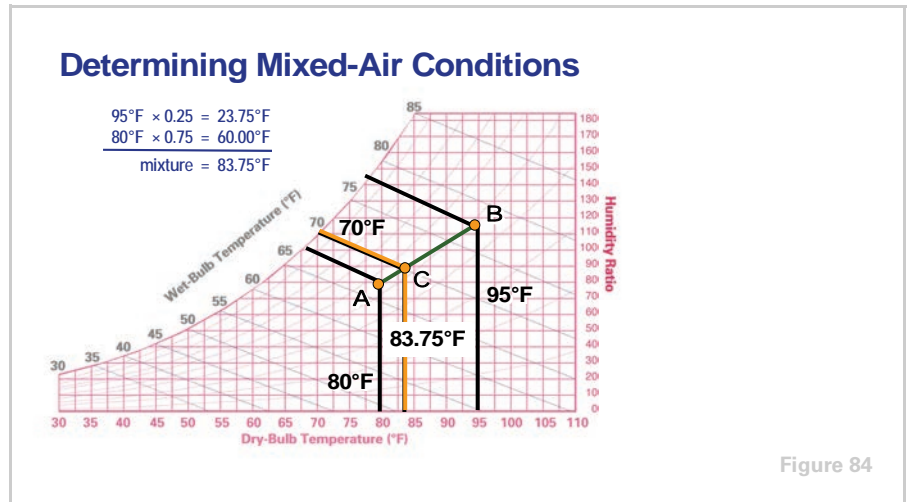

In Period Two, a method was discussed to determine the resulting properties of an air mixture. By plotting the conditions of the **outdoor air** and **recirculated air**, and using the percentage of outdoor air, the resulting condition of the air mixture was calculated and plotted on a straight line from **A** to **B** connecting the two air conditions.

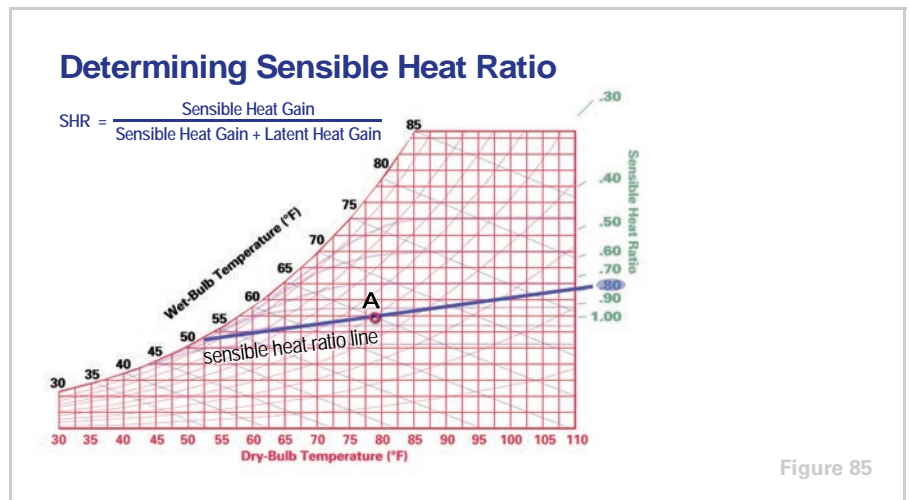

In Period Three, the **ratio of sensible heat gain to total heat gain** was discussed. With the aid of the sensible heat ratio scale on the chart, an SHR line was drawn. It was also shown that any combination of air conditions that fall on this line will maintain the desired room conditions **A**. Each set of conditions requires a different supply airflow.

period seven

Review

notes

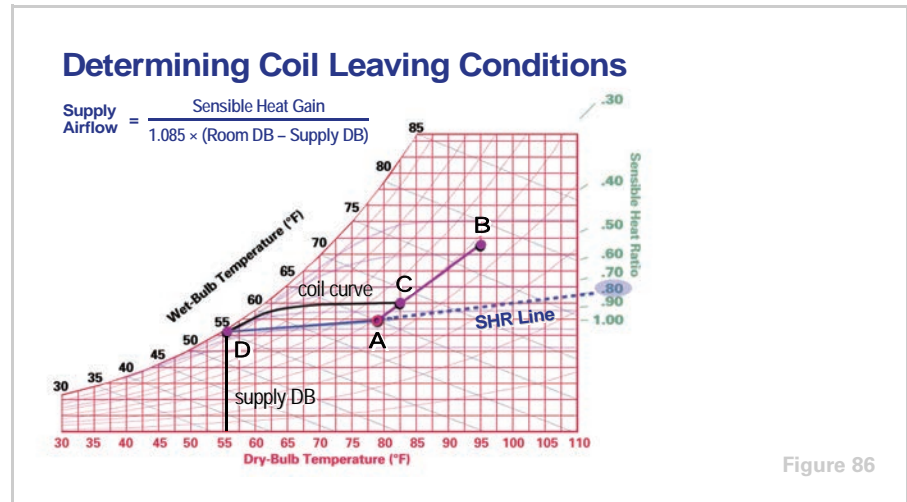

After determining the entering air conditions for the coil and the slope of the SHR line, the **coil curves** were used to find the required supply air conditions. This point (**D**) was established by the intersection of the coil curve and the SHR line.

By knowing the design room conditions **A** and the required supply air conditions **D**, the corresponding **supply airflow** could be calculated.

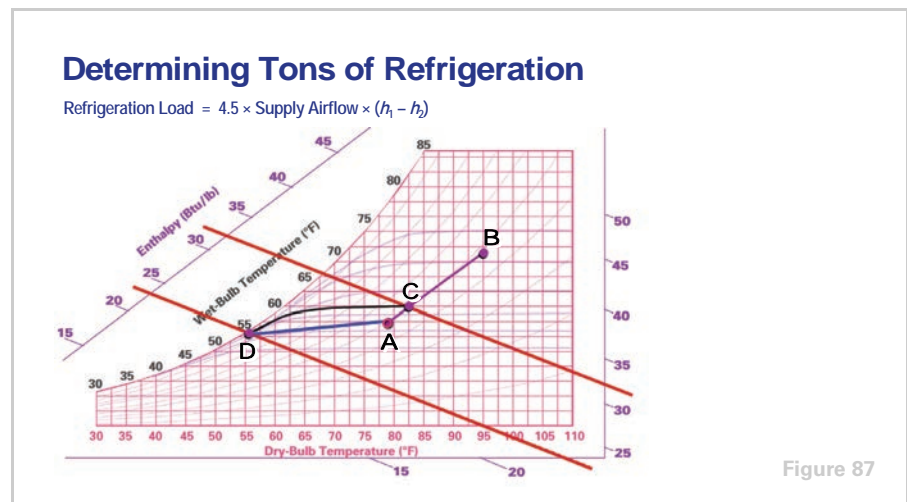

After the entering (**C**) and leaving (**D**) coil conditions were established, the **enthalpies** for each were read from the psychrometric chart. These enthalpy values and the previously calculated supply airflow were used to determine the **refrigeration load** in Btu/hr or tons.

period seven

Review

notes

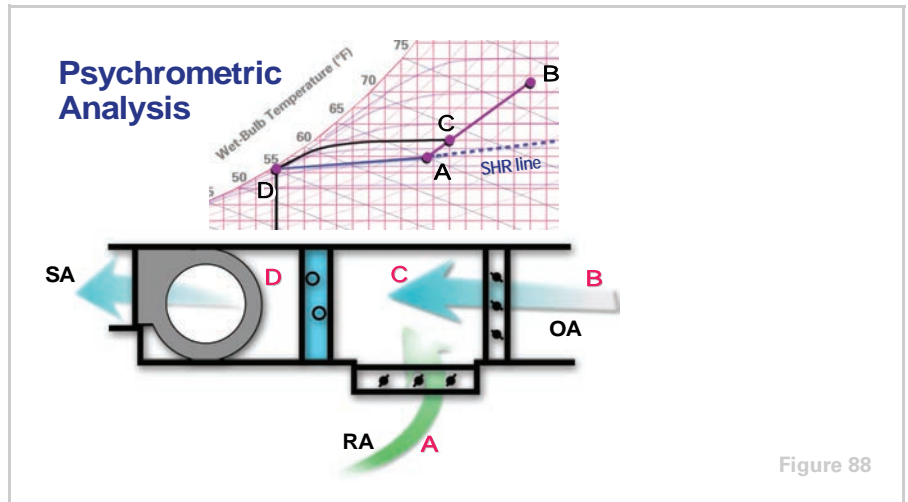

Figure 88

The resulting psychrometric chart plot represents the changes that a volume of air undergoes as it travels through a typical air conditioning system.

In this illustration, recirculated air **A** is mixed with outdoor air **B**, producing a mixed air condition **C**.

This air mixture passes through the cooling and dehumidifying coil, with the changes in dry-bulb temperature and humidity ratio represented by the coil curve from **C** to **D**.

This supply air **D** enters the room and mixes with the room air along the SHR line from **D** to **A**, absorbing the room's sensible and latent heat gains, to maintain the room at desired conditions **A**.

Again, for this specific supply air condition, a specific airflow is required to maintain the desired room conditions.

period seven
Review

notes



For more information, refer to the following references:

- Trane Air Conditioning Manual
- ASHRAE Handbook—Fundamentals
- Fundamentals of Thermodynamics and Psychrometrics, ASHRAE self-directed learning course
- Psychrometrics: Theory and Practice, ASHRAE

Visit the ASHRAE Bookstore at www.ashrae.org.

For information on additional educational materials available from Trane, contact your local Trane sales office (request a copy of the Educational Materials price sheet—Trane order number EM-ADV1) or visit our online bookstore at www.trane.com/bookstore/.

Quiz

Questions for Period 1

- 1** Given air conditions of 80°F DB and 60% RH, find the humidity ratio and dew-point temperature.
- 2** Given air conditions of 85°F DB and a humidity ratio of 90 grains/lb, find the relative humidity and wet-bulb temperature.
- 3** Given air conditions of 74°F WB and 60% RH, find the dry-bulb temperature and humidity ratio.
- 4** Given air conditions of 80°F DB and a humidity ratio of 64 grains/lb, find the relative humidity and wet-bulb temperature.
- 5** Given air conditions of 90°F DB and 68°F WB, find the dew-point temperature and relative humidity.

Questions for Period 2

- 6** Given outdoor air conditions of 95°F DB, 78°F WB; indoor design conditions of 80°F DB, 67°F WB; total airflow of 20,000 cfm; and outdoor airflow of 4,000 cfm:
 - a** Find the dry-bulb temperature of the mixture.
 - b** Plot all three conditions on the psychrometric chart.
 - c** Find the wet-bulb temperature of the mixture.
- 7** Given outdoor air conditions of 90°F DB, 80°F WB; indoor design conditions of 78°F DB, 65°F WB; total airflow of 40,000 cfm; and outdoor airflow of 6,000 cfm:
 - a** Find the dry-bulb temperature of the mixture.
 - b** Plot all three conditions on the psychrometric chart.
 - c** Find the wet-bulb temperature of the mixture.

Questions for Period 3

- 8** Given a sensible heat ratio of 0.80 and indoor design conditions of 78°F DB and 66°F WB:
 - a** Draw the SHR line on the psychrometric chart.
 - b** Find the dry-bulb and wet-bulb temperatures of the air where this SHR line crosses the 90% RH curve.

Quiz

Questions for Period 4

- 9** Given a room with a 42,000 Btu/hr sensible heat gain and a 56,000 Btu/hr total heat gain (excluding ventilation heat gain); and indoor design conditions of 80°F DB and 50% RH:
- a** Determine the sensible heat ratio.
 - b** Draw the SHR line.
- 10** Given a room with an 80,000 Btu/hr sensible heat gain, a 20,000 Btu/hr latent heat gain (excluding ventilation heat gain), and indoor design conditions of 80°F DB and 67°F WB, find the wet-bulb temperature of the supply air if it leaves the cooling coil at 60°F DB.

Questions for Period 5

- 11** Given indoor design conditions of 80°F DB and 67°F WB, if the air leaves the cooling coil at 57°F DB, find the airflow (in cfm) required to satisfy a 1,000 Btu/hr sensible heat gain.
- 12** Given that air enters the cooling coil at 85°F DB, 69°F WB and leaves at 58°F DB, 56.4°F WB, if the supply airflow is 7,000 cfm, find the total refrigeration load, in tons.
- 13** Given indoor design conditions of 78°F DB, 65°F WB; outdoor conditions of 95°F DB, 75°F WB; a sensible heat gain of 156,000 Btu/hr; a latent heat gain of 39,000 Btu/hr; and 25% outdoor air:
- a** Plot the indoor and outdoor design conditions on the psychrometric chart.
 - b** Find the mixed-air conditions entering the cooling coil.
 - c** Draw the SHR line.
 - d** Draw the coil curve and determine the coil leaving-air conditions.
 - e** Calculate the supply airflow.
 - f** Determine the enthalpy difference between the entering- and leaving-air conditions.
 - g** Calculate the refrigeration load in tons.

Answers

1 93 grains/lb, 64.8°F DP

2 49.5% RH, 70.5°F WB

3 85°F DB, 110 grains/lb

4 41% RH, 64°F WB

5 56°F DP, 32% RH

6 a $\frac{4,000 \text{ cfm}}{20,000 \text{ cfm}} = 0.20$

$$95^\circ\text{F} \times 0.20 = 19^\circ\text{F}$$

$$80^\circ\text{F} \times 0.80 = 64^\circ\text{F}$$

$$\text{Mixed-Air Temperature} = 19^\circ\text{F} + 64^\circ\text{F} = 83^\circ\text{F}$$

b See Figure 90.

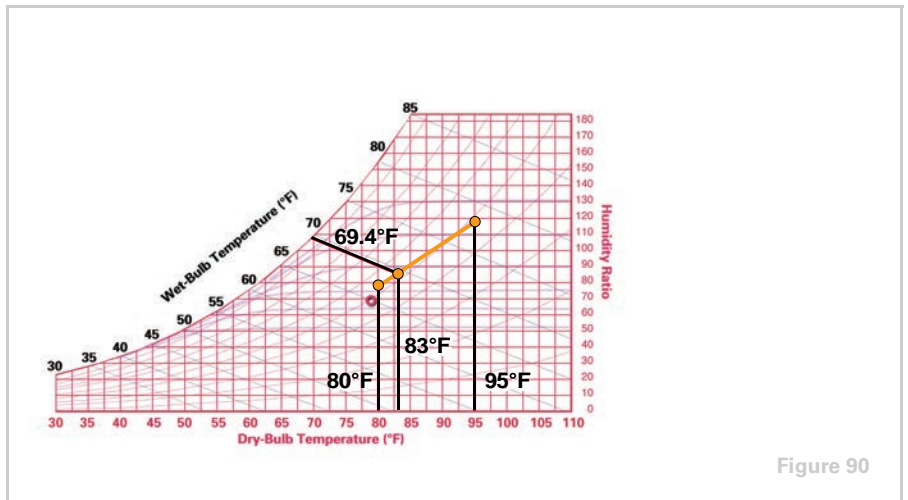

c 69.4°F WB

7 a $\frac{6,000 \text{ cfm}}{40,000 \text{ cfm}} = 0.15$

$$95^\circ\text{F} \times 0.15 = 13.5^\circ\text{F}$$

$$78^\circ\text{F} \times 0.85 = 66.3^\circ\text{F}$$

$$\text{Mixed-Air Temperature} = 13.5^\circ\text{F} + 66.3^\circ\text{F} = 79.8^\circ\text{F}$$

b See Figure 91.

c 67.4°F WB (See Figure 91.)

Answers

notes

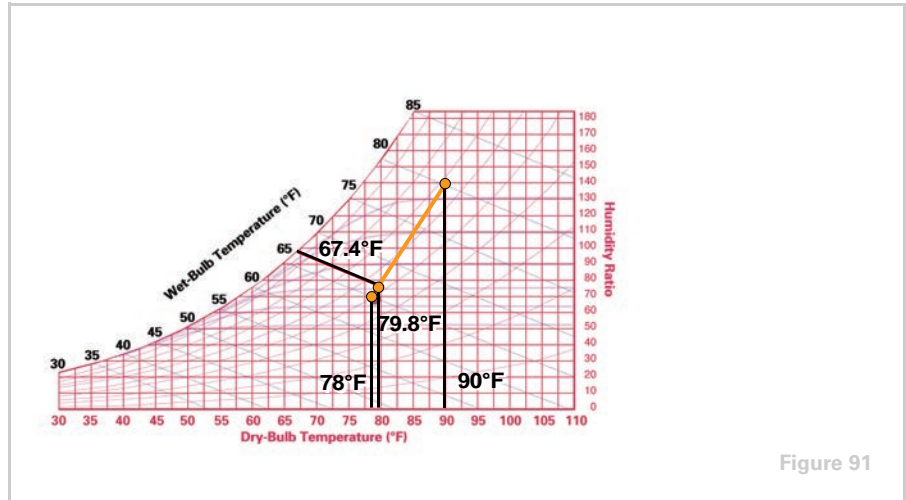

Figure 91

- 8 a** The SHR line crosses the saturation curve at 56°F WB (See Figure 92.)
b 60°F DB, 58°F WB (See Figure 92.)

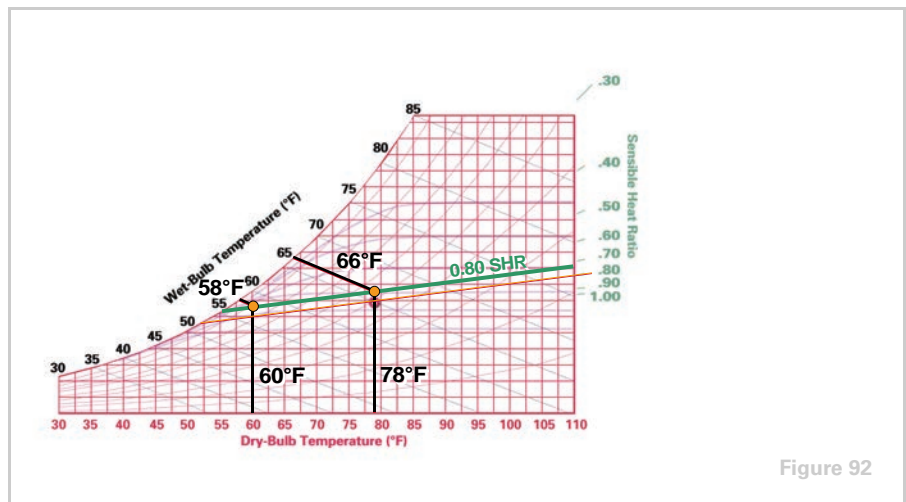

Figure 92

- 9 a**
$$\text{SHR} = \frac{42,000 \text{ Btu/hr}}{56,000 \text{ Btu/hr}} = 0.75$$

b See Figure 93.

Answers

notes

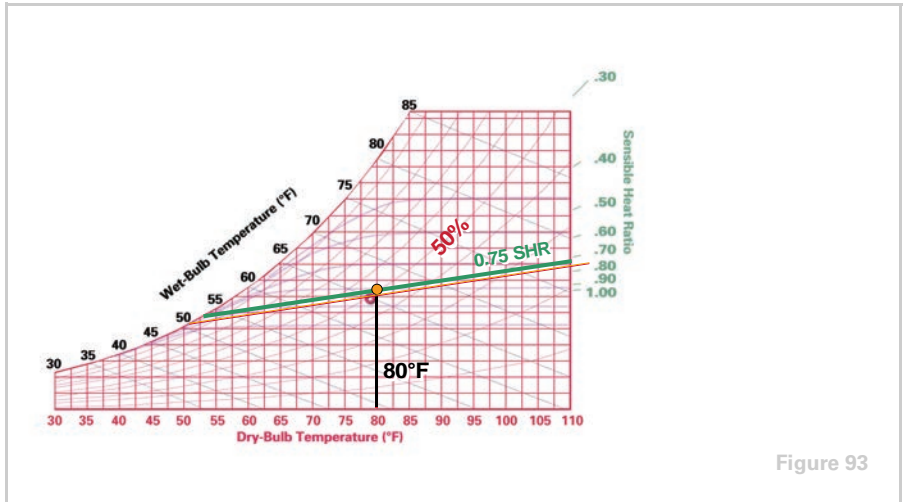

$$10 \quad \text{SHR} = \frac{80,000 \text{ Btu/hr}}{80,000 \text{ Btu/hr} + 20,000 \text{ Btu/hr}} = 0.80$$

58.3°F WB (See Figure 94.)

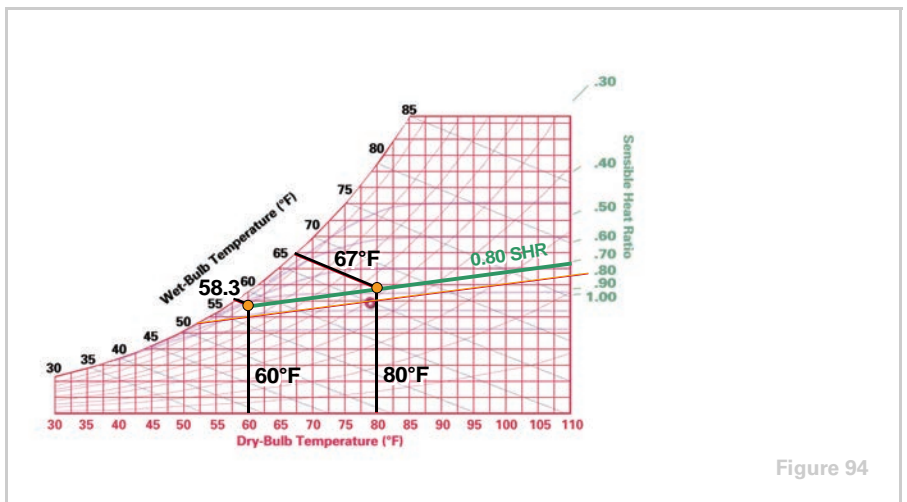

$$11 \quad \text{Supply Airflow (cfm)} = \frac{1,000 \text{ Btu/hr}}{1.085 \times (80^\circ\text{F} - 57^\circ\text{F})} = 40 \text{ cfm}$$

Answers

notes

12 See Figure 95.

$$\text{Refrigeration Load} = 4.5 \times 7,000 \text{ cfm} \times (33.2 - 24.2) = 283,500 \text{ Btu/hr}$$

$$\frac{283,500 \text{ Btu/hr}}{12,000 \text{ Btu/hr/ton}} = 23.6 \text{ tons of refrigeration}$$

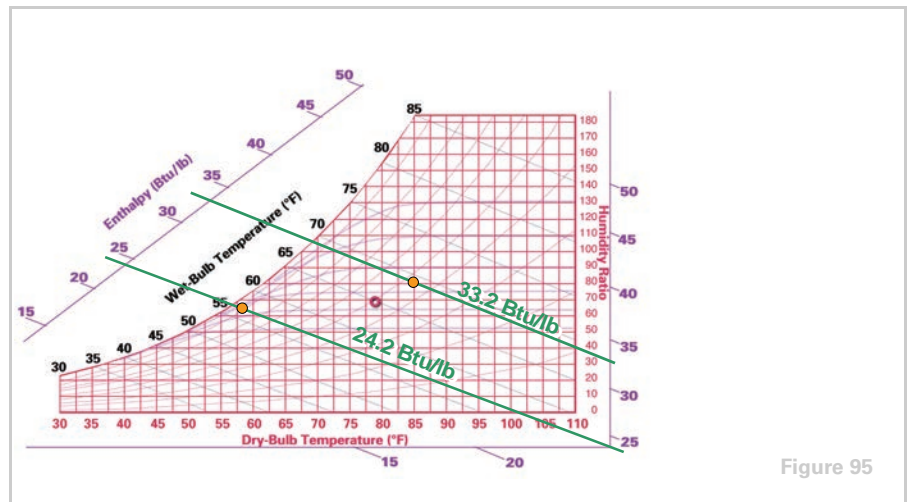

Figure 95

13 a See Figure 96.

b $95^\circ\text{F} \times 0.25 = 23.75^\circ\text{F}$

$78^\circ\text{F} \times 0.75 = 58.50^\circ\text{F}$

Mixed-Air Temperature = $23.75^\circ\text{F} + 58.50^\circ\text{F} = 82.25^\circ\text{F}$

Mixed-Air Conditions = $82.25^\circ\text{F DB}, 67.7^\circ\text{F WB}$ (See Figure 96)

c $\text{SHR} = \frac{156,000 \text{ Btu/hr}}{156,000 \text{ Btu/hr} + 39,000 \text{ Btu/hr}} = 0.80$ (See Figure 96)

d Leaving-Coil Conditions = $57^\circ\text{F DB}, 54.4^\circ\text{F WB}$ (See Figure 96)

Answers

notes

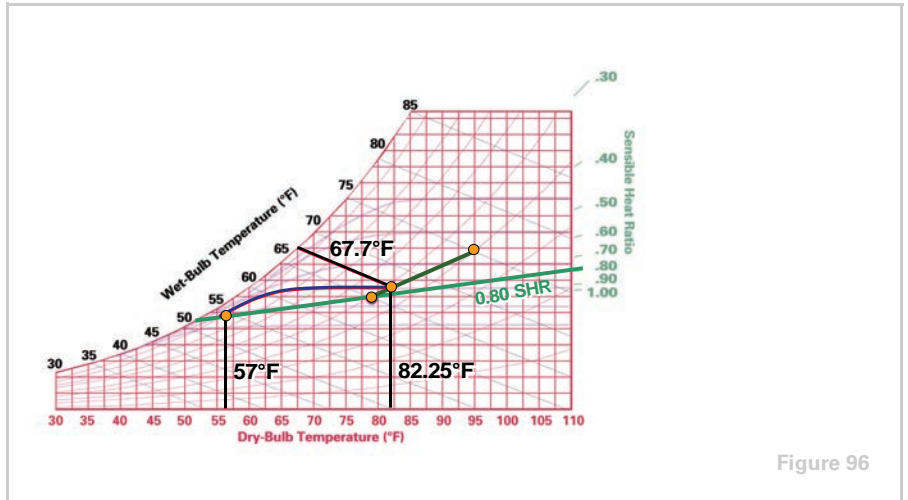

Figure 96

$$\mathbf{e} \quad \text{Airflow (cfm)} = \frac{156,000 \text{ Btu/hr}}{1.085 \times (78^\circ\text{F} - 57^\circ\text{F})} = 6,847 \text{ cfm}$$

$$\mathbf{f} \quad h_1 - h_2 = 32.1 - 23.7 = 8.4 \text{ Btu/lb}$$

$$\mathbf{g} \quad \text{Refrigeration Load} = 4.5 \times 6,847 \text{ cfm} \times 8.4 \text{ Btu/lb} = 258,817 \text{ Btu/hr}$$

$$\frac{258,817 \text{ Btu/hr}}{12,000 \text{ Btu/hr/ton}} = 21.6 \text{ tons}$$

Glossary

ASHRAE American Society of Heating, Refrigerating and Air-Conditioning Engineers

coil curves These represent the changes in dry-bulb and wet-bulb temperatures as air passes through a “typical” cooling coil.

constant-volume system A type of air-conditioning system that varies the temperature of a constant volume of air supplied to meet the changing load conditions of the space.

dew-point temperature The temperature at which moisture leaves the air and condenses on surfaces.

dry-bulb temperature A measure of the amount of sensible heat in the air.

enthalpy A quantity that describes the total amount of heat energy, both sensible and latent, in one pound of air at a given condition.

humidity ratio A quantity that describes the actual weight of the water in an air – water vapor mixture.

interior space A conditioned space that is surrounded by other conditioned spaces, with no perimeter walls or windows. It typically requires some degree of cooling all year long to overcome the heat generated by people, lighting, etc.

latent heat Heat that causes a change in the air’s moisture content with no change in dry-bulb temperature.

mixed-air bypass A method of part-load control that uses face-and-bypass dampers, located in front of the cooling coil, to vary the portion of the supply air that passes through the coil. This varies the supply air temperature as the two airstreams mix downstream of the coil.

outdoor air Air brought in to the building, either by a ventilation system or through openings provided for natural ventilation, from outside the building.

psychrometric chart A tool used to graphically display the properties of air.

psychrometry The science dealing with the physical laws of air – water mixtures.

recirculated return air Air removed from the conditioned space and reused as supply air, usually after passing through an air-cleaning and -conditioning system, for delivery to the conditioned space.

relative humidity A comparison of the amount of moisture that a given amount of air *is* holding, to the amount of moisture that the same amount of air *can* hold, at the same dry-bulb temperature.

return air Air that is removed from the conditioned space(s) and either recirculated or exhausted.

Glossary

saturation curve This represents the moisture content that constitutes complete saturation of air at the various dry-bulb temperatures.

saturation point The maximum amount of water vapor that one pound of dry air can hold at a given dry-bulb temperature.

sensible heat Heat that causes a change in the air's dry-bulb temperature with no change in moisture content.

sensible heat ratio (SHR) The ratio of sensible heat gain to total (sensible + latent) heat gain.

specific volume The volume of one pound of dry air at a specific temperature and pressure.

supply air Air that is delivered to the conditioned space by mechanical means for ventilation, heating, cooling, humidification, or dehumidification.

supply duct system A system that transports the primary air from the central air handler to the VAV terminal units and then on to the space diffusers.

ton of refrigeration A quantity that is equal to 12,000 Btu/hr.

variable-air-volume (VAV) system A type of air-conditioning system that varies the volume of constant temperature air supplied to meet the changing load conditions of the space.

wet-bulb temperature A measure of the dryness of the air, obtained by using a thermometer with a bulb that is covered by a wet wick.



Trane optimizes the performance of homes and buildings around the world. A business of Ingersoll Rand, the leader in creating and sustaining safe, comfortable and energy efficient environments, Trane offers a broad portfolio of advanced controls and HVAC systems, comprehensive building services, and parts. For more information, visit www.Trane.com.

Trane has a policy of continuous product and product data improvement and reserves the right to change design and specifications without notice.

© 2012 Trane All rights reserved
TRG-TRC001-EN 31 July 2012
Supersedes TRG-TRC001-EN (Oct 1999)

We are committed to using environmentally
conscious print practices that reduce waste.

