



Installation Operation Maintenance

Voyager™ I Rooftop Units

Cooling-only TSD/TSH 060 072 102 120

Reversible WSD/WSH 060 072 090

Gas-fired YSD/YSH 060 072 090 102 120



RT-SVX20D-E4
Original instruction



Table of Contents

General Information	4
Foreword	4
Warnings and Cautions	4
Reception	4
Warranty	4
Refrigerant	4
Storage	5
Maintenance Contract	5
Training	5
Installation	6
Reception of Units	6
Roof Curb Installation (TSD-WSD-YSD Accessories)	6
Dimensions/Weights/Clearances	7
Installing the Unit	9
Connection of Duct Network	10
Condensate Drain Piping	12
Gas Pipework Installation	13
Filter Installation	14
Supply Fan Adjustment	14
Component Air Pressure Drops	16
Supply Fan Performances	17
Electrical Connection	30
Controls	32
CO ₂ Sensors	32
Remote Potentiometer	35
Fire Thermostat	35
Clogged Filter Detector	36
Smoke Detector	36
High Temperature Safety Thermostat	36
Remote Fault Relay	36
Control Wiring	37
Thermostats	37
Communication Interfaces	38

Table of Contents

Unit Options	39
Hot Water Coil	39
Electric Heater	39
Soft Starter	39
0-50% Fresh Air Hood	40
Barometric Relief	40
Operation	41
Operation with a Conventional Thermostat	41
Setting the Economizer or 0-50% Motorized Hood (Option)	43
Test Procedures	45
Test Modes	46
Unit Start-up	47
Cooling without an Economizer	48
Low Ambient Operation	49
Cooling with an Economizer	49
Economizer Set-Up	49
ReliaTel™ Control Heating Operation	50
Ignition Module	50
Final Installation Checklist	50
Maintenance	51
End User Routine Maintenance	51
Service Technician Maintenance	51
Troubleshooting	51
Notes	52



General Information

Foreword

These instructions are given as a guide to good practice in the installation, start-up, operation, and maintenance by the user, of Trane TSD/TSH, WSKD/WSH and YSD/YSH units. They do not contain full service procedures necessary for the continued successful operation of this equipment. The services of a qualified technician should be employed through the medium of a maintenance contract with a reputable service company. Read this manual thoroughly before unit start-up.

TSD/TSH units are designed to operate in cooling mode only, with optional auxiliary heat (electric heater or hot water coil).

WSD/WSH can operate in cooling mode or heating mode by reversing the refrigeration cycle with or without auxiliary heat.

YSD/YSH units are designed to operate in cooling mode and equipped with a gas fired heating module.

TSD/TSH, WSD/WSH and YSD/YSH units are assembled, pressure tested, dehydrated, charged and run tested before shipment.

Warnings and Cautions

Warnings and Cautions appear at appropriate sections throughout this manual. Your personal safety and the proper operation of this machine require that you follow them carefully. The constructor assumes no liability for installations or servicing performed by unqualified personnel.

WARNING! Indicates a potentially hazardous situation which, if not avoided, could result in death or serious injury.

CAUTION! Indicates a potentially hazardous situation which, if not avoided, may result in minor or moderate injury. It may also be used to alert against unsafe practices or for equipment or property-damage-only accidents.

Reception

On arrival, inspect the unit before signing the delivery note. In case of visible damage: The consignee (or the site representative) must specify any damage on the delivery note, legibly sign and date the delivery note, and the truck driver must countersign it. The consignee (or the site representative) must notify Trane Epinal Operations - Claims team and send a copy of the delivery note. The customer (or the site representative) should send a registered letter to the last carrier within 3 days of delivery.

Reception in France only:

Concealed damage must be looked for at delivery and immediately treated as visible damage.

Reception in all countries except France:

In case of concealed damage: The consignee (or the site representative) must send a registered letter to the last carrier within 7 days of delivery, claiming for the described damage. A copy of this letter must be sent to Trane Epinal Operations - Claims team.

Warranty

Warranty is based on the general terms and conditions of the manufacturer. The warranty is void if the equipment is repaired or modified without the written approval of the manufacturer, if the operating limits are exceeded or if the control system or the electrical wiring is modified. Damage due to misuse, lack of maintenance or failure to comply with the manufacturer's instructions or recommendations is not covered by the warranty obligation. If the user does not conform to the rules of this manual, it may entail cancellation of warranty and liabilities by the manufacturer.

Refrigerant

The refrigerant provided by the manufacturer meets all the requirements of our units. When using recycled or reprocessed refrigerant, it is advisable to ensure its quality is equivalent to that of a new refrigerant. For this, it is necessary to have a precise analysis made by a specialized laboratory. If this condition is not respected, the manufacturer warranty could be cancelled.

General Information

Storage

Take precautions to prevent condensate formation inside the unit's electrical components and motors when:

1. The unit is stored before it is installed; or,
2. The unit is set on the roof curb and temporary auxiliary heat is provided in the building.

Isolate all side panel service entrances and base panel openings (e.g., conduit holes, S/A and R/A openings, and flue openings) to minimize ambient air from entering the unit until it is ready for start-up.

Do not use the unit's heater as temporary heat without completing the start-up procedures detailed under "Unit Start-Up".

The Trane Company will not assume responsibility for equipment damage resulting from accumulation of condensate on the unit electrical components.

Maintenance Contract

It is strongly recommended that you sign a maintenance contract with your local Service Agency. This contract provides regular maintenance of your installation by a specialist in our equipment. Regular maintenance ensures that any malfunction is detected and corrected in good time and minimizes the possibility that serious damage will occur. Finally, regular maintenance ensures the maximum operating life of your equipment. We would remind you that failure to respect these installation and maintenance instructions may result in immediate cancellation of the warranty.

Training

To assist you in obtaining the best use of it and maintaining it in perfect operating condition over a long period of time, the manufacturer has at your disposal a refrigeration and air conditioning service school. The principal aim of this is to give operators and technicians a better knowledge of the equipment they are using, or that is under their charge. Emphasis is particularly given to the importance of periodic checks on the unit operating parameters as well as on preventive maintenance, which reduces the cost of owning the unit by avoiding serious and costly breakdown.

Installation

General information: The installation must conform to all local standards and regulations.

Reception of Units

Rooftop unit

There are two ways to handle the unit:

1. Use the openings in the base to handle the machine using a forklift, in accordance with applicable safety regulations.
2. Use a lifting beam correctly adjusted to fit the unit (Figure 1).

Unit handling

The units are supplied on the truck but are not unloaded. An opening is provided on each corner of the unit base to facilitate handling. Four shackles and four slings are required. Use a lifting beam to prevent the cables pressing too hard on top of the unit during lifting. The structure accommodating the unit(s) must be designed to support the equipment in operation, as a minimum. (Refer to Figures 1 and 2 and Tables 2 and 3).

Important: For unit to fit on the roof curb the fork lift pockets must be removed.

Figure 1 - Unit handling

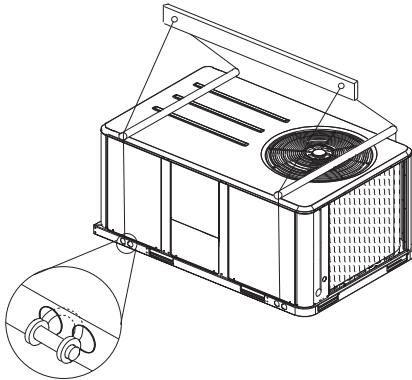

Roof curb (accessory)

Roof curbs are available as an accessory for downflow units. The curbs can be adjustable and supplied pre-assembled on wooden pallets, packed under plastic film. Two types of self-adhesive seals are provided to ensure the roof curb seal is leak-tight (40mm wide for the perimeter, 20mm wide for the crosspieces).

Roof Curb Installation (TSD-WSD-YSD Accessories)

Roof curbs are available as an accessory for "downflow" units to support the unit and ensure the water tightness between the rooftop and the roof.

The curbs can be adjustable and supplied pre-assembled on wooden pallets, packed under plastic film. Two types of self-adhesive seals are provided separate. (40mm wide for the perimeter, 20mm wide for the cross pieces). Make sure they are properly installed where indicated to assure an adequate curb to unit seal.

Instructions for the roof curb assembly and installation with curb dimensions are provided with each roof curb kit.

Figure 2 - Rigging

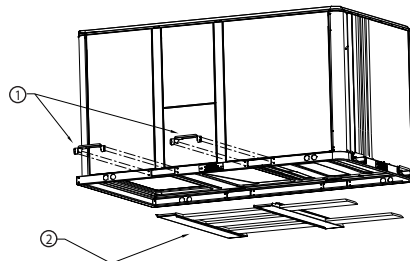

1 = Remove 2 fork lift brackets

2 = Remove 2 metal runners and 3 wooden boards

Lift the unit enough to allow the removal of two Fork Lift brackets and hardware. Remove the two Fork Lift brackets, two metal runners and three wooden boards as shown in Figure 2.

Dimensions/Weights/Clearances

The structure accommodating the unit(s) must be designed to support the equipment in operation, as a minimum. Refer to Table 2 and the space requirement plan.

Figure 3 - Minimum clearances

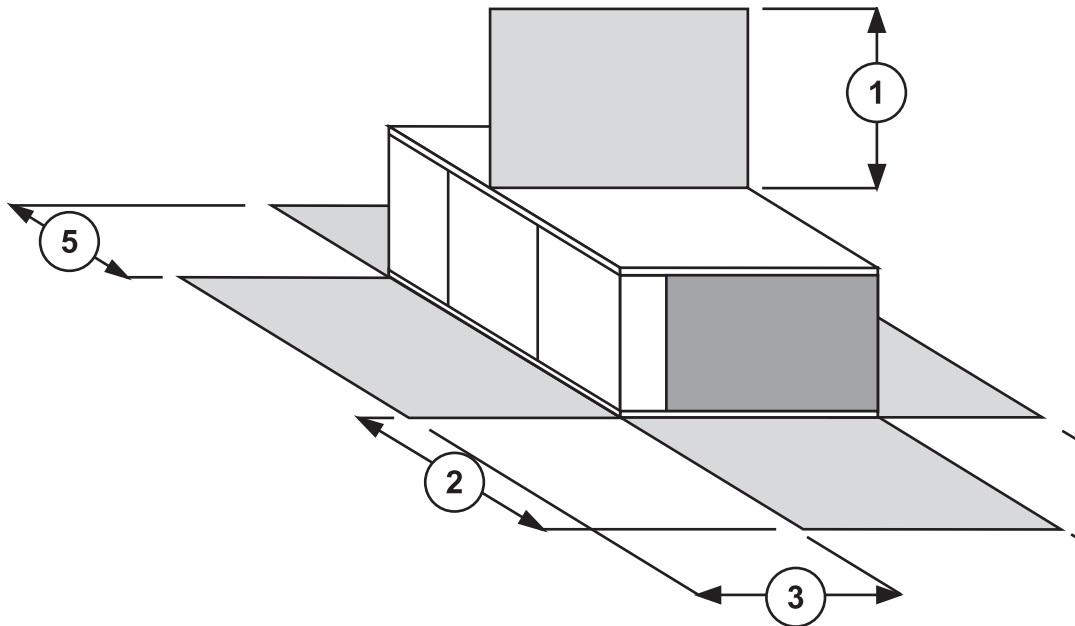

Table 1 - Minimum recommended clearances

Unit size	Mimum clearances (mm)				
	1	2	3	4	5
TSD/TSH 060	1829	1219	914	914	914
TSD/TSH 072	1829	1219	914	914	914
TSD/TSH 090	1829	1219	914	914	914
TSD/TSH 102	1829	1219	914	914	914
TSD/TSH 120	1829	1219	914	914	914
YSD/YSH 060	1829	1219	914	914	914
YSD/YSH 072	1829	1219	914	914	914
YSD/YSH 090	1829	1219	914	914	914
YSD/YSH 102	1829	1219	914	914	914
YSD/YSH 120	1829	1219	914	914	914
WSD/WSH 060	1829	1219	914	914	914
WSD/WSH 072	1829	1219	914	914	914
WSD/WSH 090	1829	1219	914	914	914

Installation

Figure 4

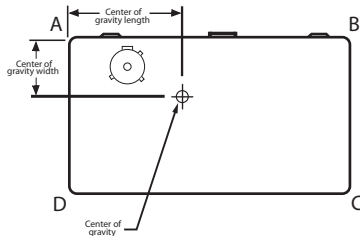

Table 2 - Unit weights and center of gravity

Unit Size	Maximum weight		Corner weight (1)				Center of gravity	
	Shipping (kg)	Net (kg)	A (kg)	B (kg)	C (kg)	D (kg)	Length (mm)	Width (mm)
060	288	240	76	58	49	57	1006	597
072	415	355	127	87	65	76	963	535
090	434	374	150	82	65	76	889	512
102	478	415	139	117	71	89	1015	520
120	489	426	148	111	79	88	1003	532
060	312	264	82	65	55	62	1025	600
072	443	383	134	95	72	82	980	542
090	461	401	157	90	72	82	909	519
102	510	447	147	126	79	95	1031	526
120	522	459	156	120	88	95	1020	538
060	304	256	77	64	44	71	945	609
072	397	337	114	84	66	73	1003	557
090	439	379	128	89	68	94	933	578

Notes:

(1) Corner weights are given for information only. All models must be supported continuously by a curb or equivalent frame support.

Table 3 - Factory-installed options and accessories net weights (kg)

Unit size	Economizer	Barometric Relief	Motorized Outside Air Damper	Manual Outside Air Damper	Roof Curb	Oversized Motor	Electric Heaters	Hot water coil
TSD/TSH 060	11.8	3.2	9.1	7.3	31.8	-	6.8	14.0
TSD/TSH 072	16.3	4.5	13.6	11.8	52.2	3.6	13.6	17.0
TSD/TSH 090	16.3	4.5	13.6	11.8	52.2	3.6	13.6	17.0
TSD/TSH 1020	16.3	4.5	13.6	11.8	52.2	3.6	13.6	19.0
TSD/TSH 120	16.3	4.5	13.6	11.8	52.2	3.6	13.6	19.0
YSD/YSH 060	11.8	3.2	9.1	7.3	31.8	-	6.8	
YSD/YSH 072	16.3	4.5	13.6	11.8	52.2	3.6	13.6	
YSD/YSH 090	16.3	4.5	13.6	11.8	52.2	3.6	13.6	
YSD/YSH 102	16.3	4.5	13.6	11.8	52.2	3.6	13.6	
YSD/YSH 120	16.3	4.5	13.6	11.8	52.2	3.6	13.6	
WSD/WSH 060	11.8	3.2	9.1	7.3	31.8	-	6.8	14.0
WSD/WSH 072	16.3	4.5	13.6	11.8	52.2	3.6	13.6	17.0
WSD/WSH 090	16.3	4.5	13.6	11.8	52.2	3.6	13.6	17.0

Notes:

- (1) Weights for options not listed are < 3 kg.
- (2) Net weight should be added to unit weight when ordering factory-installed accessories.
- (3) Some accessories are not available on all units.

Installation

Installing the Unit

Discharge Conversion

If a unit is to be converted to **Vertical** discharge, a panel must be acquired from Trane.

If a unit is to be converted to **Horizontal** discharge, the following conversion must be performed:

1. Remove the return and supply duct covers.
2. Apply gasket to the return duct cover.
3. Position duct covers as shown in Figure 4. The supply duct cover is installed (insulation side down) over the downflow return opening by engaging one side of the panel under a retaining angle and securing the other side with 3 screws.
4. Slide return duct cover (insulation side up) into supply openings until outer edge of the duct cover engages with the two retaining clips on the duct flanges. Secure the outer edge of the each duct cover with two screws.

Figure 5 - Conversion to horizontal discharge

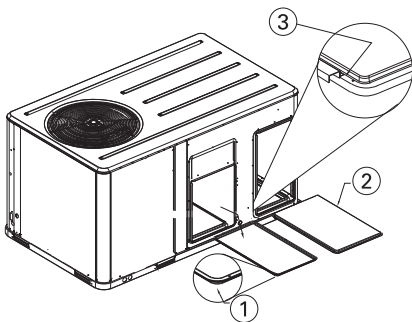

- 1 = Supply duct cover, insulation side down
 2 = Return duct cover with gasket installed, insulation side up
 3 = Edge of duct cover goes under retaining angle

Installing the unit on the ground

To install the unit on the ground, its base must be level and supported securely. For horizontal discharge units, a support is required such as a metal or concrete slab whose height must be determined according to the amount of snow cover, to prevent problems with condensation drainage and obstruction of the external coil. If necessary use an anti-vibration material between the rooftop unit's base and the support.

Note: Unit installation must comply to local codes.

Unit mounting on roof

Fix the rooftop curb on the joint beam of the building's structure. Make the rooftop curb's sealing surface level using angle brackets adjusted by screw bolts, located around its perimeter. Place the adhesive seals on the curb's sealing surface (perimeter and cross pieces). Make the rooftop leak-tight around the curbs before installing the unit, in compliance with current construction standards.

Note: The unit must be installed perfectly level to ensure condensates flow from the condensate tray.

The rooftop unit nests into the curb and is supported by it. Position the unit, taking care to comply with the indicated directions: the unit's discharge and intake openings must match those of the curb.

Figure 6 - Unit mounting on roof

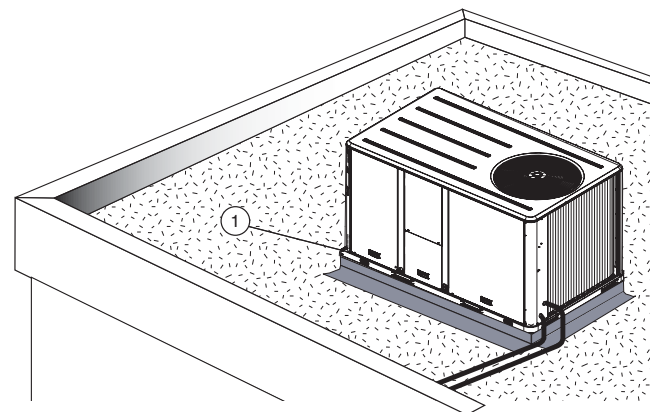

1 = Frame

Figure 7 - Unit installation on the ground

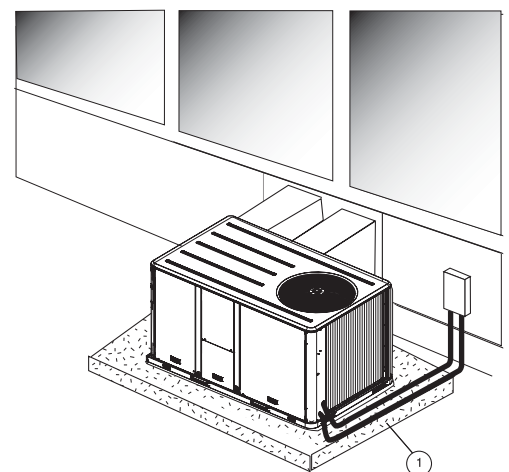

1 = Concrete slab

Installation

Connection of Duct Network

1) Downflow discharge units (TSD, WSD, YSD)

Using the rooftop curb

- The rooftop curb must be insulated on the outside walls at the discharge and intake openings to prevent condensation in the ducts.
- The rims around the discharge and intake openings make it possible to attach the flanges on the ends of the ducts. If you are using rigid duct ends recommended on the rooftop curb plan, it is essential to fix these components before installing the unit.
- For the design of the duct network, comply with recommendations currently applicable on the market, in particular:
 - Installation of a section of flexible ducts to limit transmission of the unit's vibrations
 - Use of movable vanes or deflectors to reduce the sound level.

2) Horizontal discharge units (TSH, WSH, YSH)

- The intake and discharge ducts must be insulated (thermal insulation).
- The duct section located outside must be leak-tight.
- Provide a flexible connector to prevent transmission of the unit vibrations. This flexible duct must be installed inside the building.

Note: In case of use of units with economizer option, temperature and humidity sensors must be installed in return duct.

Economizer linkage is factory mounted but the damper position must be adjusted on site.

Table 4 - Duct dimensions for downflow units (mm)

Unit size	A	B	C	D	E	Flanges
TSD/YSD/WSD 060	619	357	411	459	356	31
TSD/YSD 072/090/102/120 WSD 072/090	857	451	451	857	356	31

Table 5 - Duct dimensions for horizontal units (mm)

Unit size	A	B	C	D
TSH/YSH/WSH 060	591	337	375	438
TSH/YSH 072/090/102/120 WSH 072/090	832	425	606	489

Figure 8 - Duct dimensions for downflow units

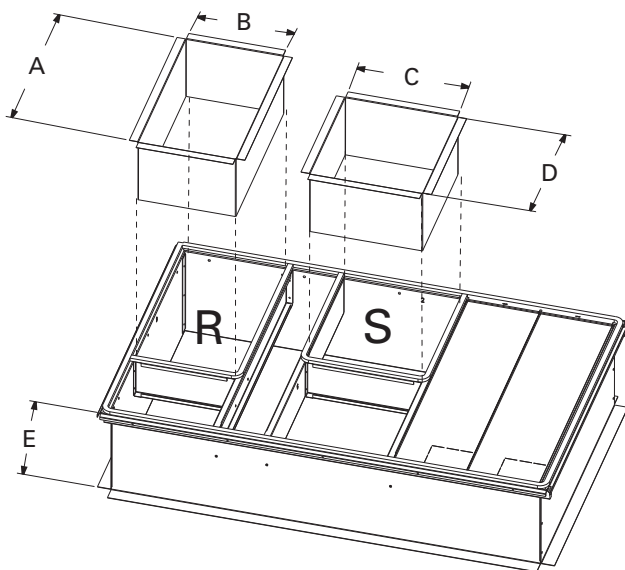

S = Supply
R = Return

Figure 9 - Duct dimensions for horizontal units

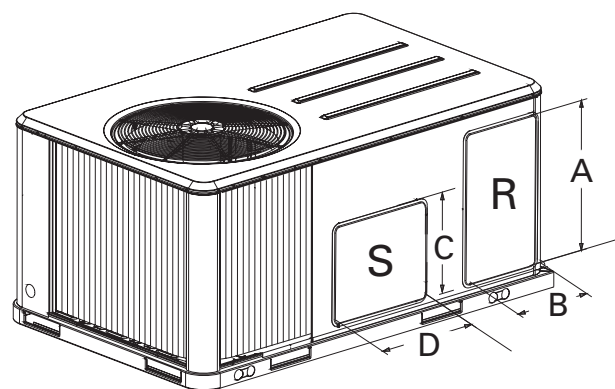

S = Supply
R = Return

Condensate Drain Piping

A 3/4" condensate drain connection with P-trap is provided. Follow local codes and standard piping practices when running the drain line. Install a trap and be sure to fill with water before starting the unit. Pitch the line downward, away from the unit to avoid long, level, horizontal runs. Refer to Figure 11.

The condensate drain is reversible to allow installation of a drain tap on either side of the unit.

Figure 10 - Condensate drain location

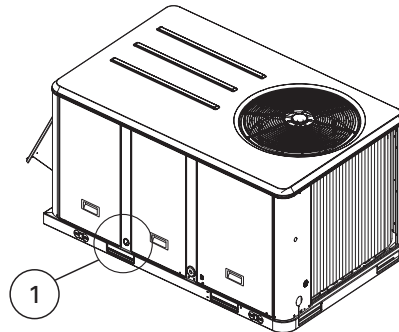

1 = Main condensate drain location

Figure 11 - Condensate drain line location

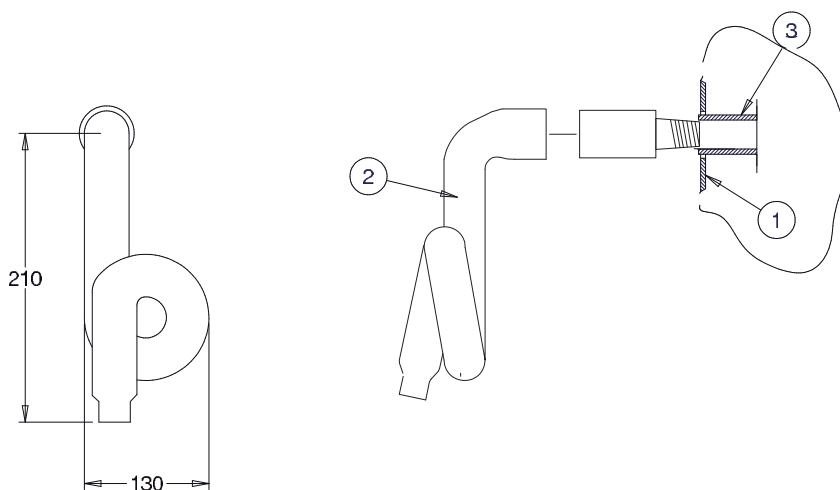

1 = Panel enclosure
 2 = Atmospheric pressure
 3 = Static drain

Installation

Gas Pipework Installation

The installation must conform to all standards and regulations.

The gas supply pipework and gas stop valve to be installed near the unit must be sized so as to ensure the gas pressure is sufficient at the unit inlet when operating at full load.

CAUTION! Should the pressure at the unit valve gas inlet be higher than 0.035 bar, an expansion valve must be installed.

The pipework must be self-supporting and the final connection to the burner must be made by a flexible pipe. Provide a dust protection (filter) upstream the unit connection.

CAUTION! The gas pipework must not exert any stress on the burner gas connection.

Note: Expansion valve must be adapted to the type of gas used:

- G 20: 20mb
- G 25: 25mb
- G 31 (Propane): 37 or 50mb

Table 6 - Gas burner models

Unit	Burner size
YSD/YSH 060	G120
YSD/YSH 072	G200
YSD/YSH 090	G200
YSD/YSH 102	G250
YSD/YSH 120	G250

See Table 51 for burner performance.

Gas leak check procedure

1. Vent the gas line
2. Gas supply line pressure test: close valve 4 and open valve 2
3. Leak-check the gas pipe.

Look for gas pipe leaks using "Typol", "1000 bulles" or a similar product. Do not use soapy water.

WARNING! Never use an open flame to check for gas leaks.

Required gas pressure at the unit inlet connection are given in Table 50.

Note: To operate with propane gas, the burner is fitted with a pressure limiter (supplied by Trane)

Figure 12 - Typical gas supply pipework

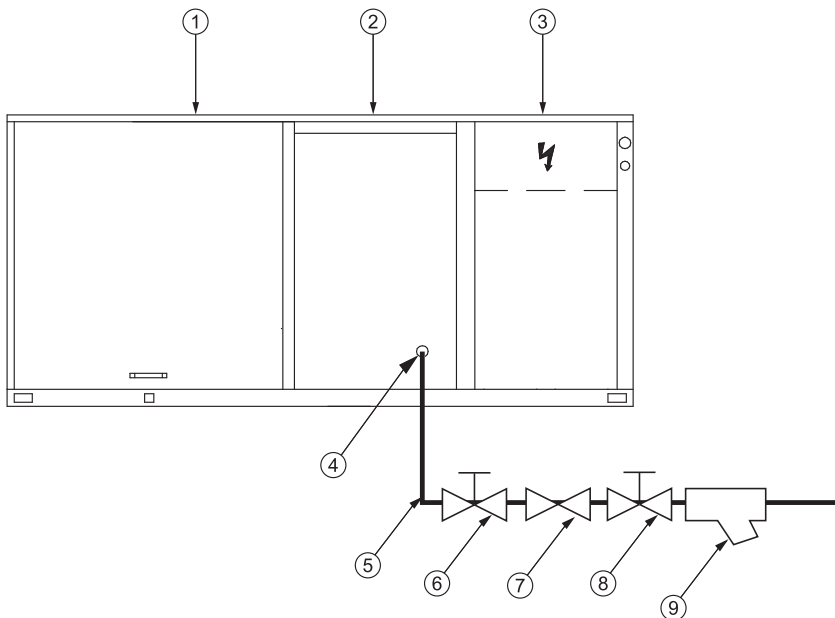

- 1 = Evaporator section
- 2 = Gas burner section
- 3 = Condenser section
- 4 = Gas supply connection
- 5 = Gas supply line
- 6, 8 = Gas stop valve (Field supplied)
- 7 = Expansion valve (Field supplied)
- 9 = Filter (Field supplied)

Installation

Filter Installation

To gain access to filters, remove the supply fan access panel on downflow units and the filter access panel on the end for horizontal units.

Number and size of filters is determined by size and configuration of the unit. If disposable filters were chosen as an option, they are shipped in the supply fan section.

CAUTION! Do not operate unit without filters in place.

The maximum pressure drops allowable on filters are:

EU2/G2: 120 Pa

EU4/G4: 150 Pa

To increase airflow

Loosen variable sheave set screw and turn sheave clockwise.

To decrease airflow

Loosen variable sheave set screw and turn sheave counter-clockwise.

To adjust belt

The fan belts must be inspected periodically to assure proper unit operation. Replacement is necessary if the belts appear frayed or worn.

Units with dual belts require a matched set of belts to ensure equal belt length.

When removing or installing the new belts, do not stretch them over the sheaves. Loosen the belts using the belt tension adjustment bolts on the motor mounting base.

Once the new belts are installed, adjust the belt tension.

Table 7 - Filter arrangement

Unit	EU2/G2		EU4/G4	
	Quantity	Size	Quantity	Size
TSD/TSH/YSD/YSH/WSD/WSH 060	2	(508x762x25)	2	(500x750x25)
TSD/TSH/YSD/YSH/WSD/WSH 072	4	(406x635x50)	4	(395x625x50)
TSD/TSH/YSD/YSH/WSD/WSH 090	4	(406x635x50)	4	(395x625x50)
TSD/TSH/YSD/YSH 102	4	(508x635x50)	4	(500x625x50)
TSD/TSH/YSD/YSH 120	4	(508x635x50)	4	(500x625x50)

Supply Fan Adjustment

Use the following procedure to determine the proper adjustment of the supply fan for a specific application.

- Determine total external static pressure about system and accessories.
 - Obtain the design airflow rate and the design external static pressure drop through the distribution system.
 - Add static pressure drop of the accessories installed on the unit. (Table 9)
 - Add the total accessory static pressure drop (from step 1b) to the design external static pressure (from step 1a). The sum of these two values is the total system external static pressure.
- Using the Tables 10 through 35 to find the external static pressure that most closely approximates total system external static pressure. Then locate the appropriate airflow rate for your unit. The value obtained represents the brake horsepower for the supply fan motor and the fan RPM.
- Adjust motor sheave according to Table 8.



Installation

Table 8 - Motor sheave/Fan speed

Unit	Fan speed (RPM) Standard drive & motor						
	6 turns Open	5 turns Open	4 turns Open	3 turns Open	2 turns Open	1 turns Open	Closed
TSD/TSH 060	N/A	898	967	1036	1105	1174	1243
TSD/TSH 072	N/A	698	751	806	859	913	967
TSD/TSH 090	N/A	752	806	860	914	968	1020
TSD/TSH 102	N/A	688	737	786	835	885	934
TSD/TSH 120	N/A	782	838	894	950	1006	1062
YSD/YSH 060	N/A	1036	1105	1174	1243	1312	1381
YSD/YSH 072	N/A	806	860	913	968	1022	1074
YSD/YSH 090	859	913	967	1021	1075	1129	N/A
YSD/YSH 102	786	836	885	934	982	1032	N/A
YSD/YSH 120	894	950	1006	1062	1118	1174	N/A
WSD/WSH 060	N/A	898	967	1036	1105	1174	1243
WSD/WSH 072	N/A	698	751	806	859	913	967
WSD/WSH 090	N/A	752	806	860	914	968	1020

Unit	Fan speed (RPM) Oversized drive & motor						
	6 turns Open	5 turns Open	4 turns Open	3 turns Open	2 turns Open	1 turns Open	Closed
TSD/TSH 060	N/A	1243	1311	1379	1450	1515	1588
TSD/TSH 072	N/A	967	1021	1075	1128	1183	1235
TSD/TSH 090	1112	1182	1252	1322	1392	1460	N/A
TSD/TSH 102	N/A	971	1041	1111	1181	1251	1321
TSD/TSH 120	1062	1118	1174	1229	1285	1341	N/A
YSD/YSH 060	-	-	-	-	-	-	-
YSD/YSH 072	N/A	967	1021	1075	1128	1183	1235
YSD/YSH 090	1112	1182	1252	1322	1392	1460	N/A
YSD/YSH 102	N/A	971	1041	1111	1181	1251	1321
YSD/YSH 120	1062	1118	1174	1229	1285	1341	N/A
WSD/WSH 060	N/A	1243	1311	1379	1450	1515	1588
WSD/WSH 072	N/A	967	1021	1075	1128	1183	1235
WSD/WSH 090	1112	1182	1252	1322	1392	1460	N/A

Component air Pressure Drops

Table 9 - Pressure drop through accessories

Unit size	Airflow (m ³ /h)	Filter EU2/G2	Filter EU4/G4	Economizer 100% outside air	Electric heater	Hot water coil
060	3060	31	50	38	17	49
	3400	38	55	46	21	55
	3740	46	61	55	25	62
	4080	55	66	64	30	68
072	3670	13	37	27	7	46
	4080	16	42	29	9	52
	4490	19	46	31	11	58
	4900	23	50	33	13	64
090	4590	19	47	33	12	66
	5100	24	52	39	15	74
	5610	29	57	45	20	83
	6120	35	62	52	25	92
102	5200	16	42	40	8	64
	5780	20	47	50	10	72
	6360	25	52	62	12	81
	6940	30	57	75	15	90
120	6120	22	50	52	11	84
	6800	27	55	62	14	95
	7480	33	61	73	17	106
	8160	40	66	85	20	117



Installation

Supply Fan Performances

Table 10 - TSD 060 Available static pressure

External Static Pressure (Pa)																									
		25		50		75		100		125		150		175		200		225		250		275		300	
m ² /h	RPM	kW	RPM	kW	RPM	kW	RPM	kW	RPM	kW	RPM	kW	RPM	kW	RPM	kW	RPM	kW	RPM	kW	RPM	kW	kW	kW	
2720	-	-	-	-	-	-	-	-	-	-	-	899	0.43	944	0.49	985	0.54	1023	0.59	1060	0.64	1093	0.69	1126	0.74
3060	-	-	-	-	-	-	-	-	-	904	0.49	947	0.54	988	0.58	1028	0.64	1067	0.70	1104	0.76	1138	0.82	1171	0.87
3400	-	-	-	-	-	-	918	0.57	958	0.62	998	0.67	1036	0.71	1073	0.76	1111	0.82	1147	0.89	1182	0.96	1215	1.02	
3740	-	-	-	-	930	0.65	977	0.71	1016	0.77	1053	0.82	1089	0.88	1124	0.93	1158	0.98	1191	1.03	1226	1.10	1258	1.17	
4080	909	0.71	950	0.76	990	0.80	1034	0.87	1074	0.93	1110	1.00	1143	1.06	1177	1.12	1209	1.17	1241	1.23	1272	1.29	-	-	

		325		350		375	
m ² /h		kW	kW	kW	kW	kW	kW
2720	1160	0.79	1190	0.84	1222	0.90	
3060	1203	0.93	1232	0.98	1262	1.04	
3400	1246	1.09	1276	1.15	1306	1.21	
3740	1290	1.25	-	-	-	-	
4080	-	-	-	-	-	-	

Table 11 - TSH 060 Available static pressure

External Static Pressure (Pa)																										
		25		50		75		100		125		150		175		200		225		250		275		300		
m ² /h	RPM	kW	RPM	kW	RPM	kW	RPM	kW	RPM	kW	RPM	kW	RPM	kW	RPM	kW	RPM	kW	RPM	kW	RPM	kW	Fan RPM	kW	Fan RPM	kW
2720	-	-	-	-	-	-	898	0.43	953	0.48	1001	0.54	1045	0.59	1087	0.65	1129	0.71	1168	0.77	1206	0.83	1241	0.89		
3060	-	-	-	-	897	0.48	953	0.54	1008	0.60	1058	0.67	1102	0.73	1143	0.79	1181	0.85	1219	0.92	1256	0.99	1291	1.05		
3400	-	-	908	0.54	961	0.60	1012	0.67	1062	0.74	1111	0.81	1157	0.88	1198	0.95	1237	1.02	1274	1.09	1309	1.16	1343	1.24		
3740	923	0.63	978	0.69	1028	0.76	1075	0.83	1120	0.91	1166	0.99	1211	1.06	1254	1.14	1294	1.22	1330	1.29	-	-	-	-	-	-
4080	997	0.80	1049	0.87	1096	0.94	1140	1.02	1183	1.10	1223	1.18	1266	1.27	-	-	-	-	-	-	-	-	-	-	-	-

		325		350		375	
m ² /h		kW	kW	kW	kW	kW	kW
2720	1275	0.96	1306	1.02	1338	1.09	
3060	1326	1.12	1359	1.19	1390	1.26	
3400	1376	1.31	-	-	-	-	
3740	-	-	-	-	-	-	
4080	-	-	-	-	-	-	

Standard drive
 Oversize drive
 Note: Data includes

Note: Data includes pressure drops for standard filters and wet coils

Installation

Table 12 - TSD 072 Available static pressure

External Static Pressure (Pa)																									
		25		50		75		100		125		150		175		200		225		250		275		300	
m ³ /h	RPM	kW	RPM	kW	RPM	kW	RPM	kW	RPM	kW	RPM	kW	RPM	kW	RPM	kW	RPM	kW	RPM	kW	Fan RPM	kW	Fan RPM	kW	
3260	-	-	-	-	-	-	-	-	-	-	-	726	0.41	769	0.47	811	0.52	851	0.58	889	0.65	925	0.71	960	0.77
3670	-	-	-	-	-	-	-	-	-	706	0.43	751	0.49	792	0.55	832	0.61	871	0.67	908	0.74	944	0.81	978	0.87
4080	-	-	-	-	-	-	-	-	-	732	0.51	777	0.58	818	0.64	856	0.71	893	0.77	930	0.84	964	0.91	998	0.99
4490	-	-	-	-	-	-	715	0.54	758	0.60	802	0.68	845	0.75	883	0.82	919	0.89	953	0.96	986	1.04	1019	1.11	
4890	-	-	-	-	706	0.58	749	0.64	789	0.71	830	0.79	870	0.87	909	0.95	945	1.02	979	1.10	1011	1.18	1043	1.26	

		325		350		375	
m ³ /h	Fan RPM	kW	Fan RPM	kW	Fan RPM	kW	
3260	994	0.83	1026	0.89	1057	0.95	
3670	1010	0.94	1043	1.01	1073	1.08	
4080	1030	1.06	1063	1.14	1092	1.21	
4490	1051	1.19	1082	1.27	1112	1.35	
4890	1073	1.34	1103	1.42	1133	1.51	

Table 13 - TSH 072 Available static pressure

External Static Pressure (Pa)																										
		25		50		75		100		125		150		175		200		225		250		275		300		
m ³ /h	RPM	kW	RPM	kW	RPM	kW	RPM	kW	RPM	kW	RPM	kW	RPM	kW	RPM	kW	RPM	kW	RPM	kW	RPM	kW	Fan RPM	kW	Fan RPM	kW
3260	-	-	-	-	-	-	-	-	-	726	0.39	771	0.45	814	0.51	857	0.57	899	0.63	939	0.70	978	0.76	1015	0.83	
3670	-	-	-	-	-	-	716	0.42	762	0.48	804	0.54	843	0.60	883	0.67	922	0.74	960	0.81	996	0.87	1034	0.95		
4080	-	-	-	-	701	0.45	751	0.51	798	0.59	839	0.65	877	0.71	914	0.78	950	0.85	984	0.93	1020	1.00	1055	1.08		
4490	-	-	710	0.51	745	0.56	788	0.62	833	0.69	875	0.77	914	0.85	949	0.91	984	0.98	1016	1.06	1049	1.14	1081	1.23		
4890	726	0.58	762	0.64	795	0.70	828	0.76	869	0.82	911	0.91	950	0.99	986	1.07	1019	1.14	1051	1.22	1081	1.30	1112	1.38		

		325		350		375	
m ³ /h	Fan RPM	kW	Fan RPM	kW	Fan RPM	kW	
3260	1051	0.90	1086	0.97	1118	1.04	
3670	1069	1.02	1103	1.09	1136	1.17	
4080	1089	1.16	1122	1.23	1154	1.31	
4490	1113	1.31	1144	1.40	1176	1.48	
4890	1141	1.47	1170	1.57	1199	1.66	

Standard drive
 Oversize drive

Note: Data includes pressure drops for standard filters and wet coils



Installation

Table 14 - TSD 090 Available static pressure

m ³ /h	External Static Pressure (Pa)																								
	25		50		75		100		125		150		175		200		225		250		275		300		
	RPM	kW	RPM	kW	RPM	kW	RPM	kW	RPM	kW	RPM	kW	RPM	kW	RPM	kW	RPM	kW	RPM	kW	Fan RPM	kW	Fan RPM	kW	
4080	-	-	-	-	-	-	-	-	-	750	0.54	794	0.60	834	0.67	873	0.73	909	0.80	945	0.87	980	0.95	1013	1.02
4590	-	-	-	-	-	-	-	-	-	787	0.66	830	0.74	871	0.82	908	0.89	943	0.96	977	1.04	1010	1.11	1043	1.19
5100	-	-	-	-	747	0.68	789	0.74	827	0.82	867	0.90	906	0.98	944	1.06	980	1.15	1013	1.23	1045	1.31	1076	1.39	
5610	-	-	755	0.77	797	0.85	836	0.92	873	1.00	908	1.08	944	1.17	980	1.26	1016	1.35	1050	1.45	1081	1.54	1111	1.63	
6120	771	0.88	809	0.96	848	1.06	885	1.14	921	1.22	954	1.30	986	1.39	1019	1.49	1052	1.58	1085	1.69	1116	1.79	1148	1.89	

m ³ /h	325		350		375	
	Fan RPM	kW	Fan RPM	kW	Fan RPM	kW
4080	1046	1.10	1076	1.17	1106	1.25
4590	1074	1.27	1105	1.36	1134	1.44
5100	1105	1.47	1134	1.56	1163	1.65
5610	1141	1.72	1168	1.80	1197	1.90
6120	1177	1.99	1204	2.08	1232	2.18

Table 15 - TSH 090 Available static pressure

m ³ /h	External Static Pressure (Pa)																							
	25		50		75		100		125		150		175		200		225		250		275		300	
	RPM	kW	RPM	kW	RPM	kW	RPM	kW	RPM	kW	RPM	kW	RPM	kW	RPM	kW	RPM	kW	RPM	kW	Fan RPM	kW	Fan RPM	kW
4080	-	-	-	-	-	-	769	0.54	814	0.61	855	0.67	893	0.73	929	0.81	965	0.88	999	0.96	1035	1.04	1070	1.12
4590	-	-	-	-	773	0.62	817	0.68	862	0.76	904	0.85	941	0.92	975	0.98	1009	1.06	1041	1.14	1073	1.22	1104	1.31
5100	771	0.68	805	0.74	837	0.81	870	0.87	912	0.94	951	1.03	989	1.12	1025	1.21	1056	1.28	1088	1.36	1117	1.44	1146	1.53
5610	842	0.89	873	0.96	903	1.03	930	1.10	963	1.17	1000	1.25	1037	1.34	1073	1.45	1106	1.55	1136	1.63	1165	1.72	1194	1.80
6120	913	1.14	942	1.22	970	1.30	996	1.37	1021	1.45	1052	1.52	1086	1.61	1121	1.71	1153	1.82	1184	1.93	1215	2.04	1242	2.13

m ³ /h	325		350		375	
	Fan RPM	kW	Fan RPM	kW	Fan RPM	kW
4080	1104	1.19	1137	1.27	1168	1.35
4590	1136	1.40	1167	1.48	1198	1.57
5100	1176	1.62	1205	1.72	1233	1.82
5610	1220	1.88	1248	1.98	1275	2.08
6120	1269	2.22	1295	2.31	1319	2.40

Standard drive
 Oversize drive

Note: Data includes pressure drops for standard filters and wet coils

Installation

Table 16 - TSD 102 Available static pressure

External Static Pressure (Pa)																									
		25		50		75		100		125		150		175		200		225		250		275		300	
m ³ /h	RPM	kW	RPM	kW	RPM	kW	RPM	kW	RPM	kW	RPM	kW	RPM	kW	RPM	kW	RPM	kW	RPM	kW	Fan RPM	kW	Fan RPM	kW	
4620	-	-	-	-	-	-	-	-	-	-	-	695	0.62	733	0.71	769	0.81	802	0.90	833	1.00	863	1.11	892	1.21
5200	-	-	-	-	-	-	-	-	-	688	0.64	725	0.73	761	0.83	796	0.93	828	1.03	861	1.13	891	1.24	919	1.35
5780	-	-	-	-	-	-	689	0.68	724	0.76	759	0.86	792	0.96	825	1.07	856	1.18	887	1.28	917	1.40	946	1.51	
6350	-	-	-	-	693	0.72	729	0.82	764	0.92	795	1.01	826	1.11	857	1.22	887	1.34	916	1.46	945	1.58	974	1.70	
6930	-	-	706	0.80	738	0.89	770	0.98	804	1.09	834	1.19	864	1.30	892	1.40	920	1.52	948	1.64	976	1.78	1002	1.91	

		325		350		375		400		425		450		475		500	
m ³ /h	Fan RPM	kW	Fan RPM	kW	Fan RPM	kW	Fan RPM	kW	Fan RPM	kW	Fan RPM	kW	Fan RPM	kW	Fan RPM	kW	
4620	920	1.33	946	1.44	973	1.55	999	1.67	1025	1.79	1050	1.90	1073	2.02	1098	2.14	
5200	946	1.46	973	1.58	999	1.71	1024	1.83	1048	1.96	1072	2.09	1096	2.22	1119	2.34	
5780	974	1.63	1001	1.75	1026	1.88	1051	2.01	1074	2.14	1099	2.27	1121	2.41	1143	2.55	
6350	1001	1.82	1028	1.95	1054	2.08	1079	2.20	1103	2.34	1126	2.48	1148	2.62	1170	2.76	
6930	1029	2.04	1055	2.17	1081	2.30	1105	2.43	1130	2.58	1154	2.72	1176	2.85	1199	3.01	

Table 17 - TSH 102 Available static pressure

External Static Pressure (Pa)																									
		25		50		75		100		125		150		175		200		225		250		275		300	
m ³ /h	RPM	kW	RPM	kW	RPM	kW	RPM	kW	RPM	kW	RPM	kW	RPM	kW	RPM	kW	RPM	kW	RPM	kW	Fan RPM	kW	Fan RPM	kW	
4620	-	-	-	-	-	-	689	0.58	734	0.67	781	0.77	826	0.88	865	0.98	898	1.07	928	1.16	956	1.25	982	1.33	
5200	-	-	-	-	693	0.64	735	0.73	773	0.82	812	0.92	855	1.03	897	1.15	934	1.27	969	1.38	999	1.49	1026	1.58	
5780	-	-	711	0.75	743	0.82	781	0.91	819	1.01	853	1.11	886	1.21	925	1.34	964	1.47	1000	1.60	1034	1.73	1067	1.86	
6350	735	0.89	770	0.97	799	1.04	830	1.12	865	1.23	899	1.34	930	1.45	960	1.56	994	1.68	1028	1.82	1063	1.96	1098	2.11	
6930	796	1.14	828	1.23	857	1.31	883	1.39	913	1.48	945	1.60	977	1.72	1006	1.84	1034	1.96	1061	2.08	1093	2.23	1125	2.38	

		325		350		375		400		425		450		475		500	
m ³ /h	Fan RPM	kW	Fan RPM	kW	Fan RPM	kW	Fan RPM	kW	Fan RPM	kW	Fan RPM	kW	Fan RPM	kW	Fan RPM	kW	
4620	1008	1.42	1033	1.51	1056	1.60	1079	1.69	1102	1.78	1125	1.87	1146	1.95	1168	2.04	
5200	1052	1.68	1078	1.78	1101	1.88	1124	1.98	1146	2.08	1168	2.18	1188	2.27	1209	2.37	
5780	1094	1.97	1120	2.08	1145	2.20	1168	2.31	1191	2.42	1213	2.53	1234	2.63	1254	2.74	
6350	1129	2.26	1158	2.40	1185	2.53	1210	2.66	1234	2.78	1256	2.90	1278	3.03	1299	3.15	
6930	1157	2.53	1188	2.70	1218	2.86	1245	3.01	1273	3.16	1297	3.31	-	-	-	-	

Standard drive
 Oversize drive

Note: Data includes pressure drops for standard filters and wet coils



Installation

Table 18 - TSD 120 Available static pressure

External Static Pressure (Pa)																										
		25		50		75		100		125		150		175		200		225		250		275		300		
m ³ /h	RPM	kW	RPM	kW	RPM	kW	RPM	kW	RPM	kW	RPM	kW	RPM	kW	RPM	kW	RPM	kW	RPM	kW	Fan RPM	kW	Fan RPM	kW		
5440	-	-	-	-	-	-	-	-	-	-	-	-	-	-	789	0.93	822	1.03	856	1.14	887	1.25	917	1.36	945	1.47
6120	-	-	-	-	-	-	-	-	-	-	-	-	797	0.99	829	1.10	860	1.22	892	1.34	922	1.46	951	1.57	979	1.69
6800	-	-	-	-	-	-	782	1.01	814	1.11	844	1.21	874	1.32	903	1.44	932	1.56	960	1.69	988	1.82	1015	1.95	-	-
7480	-	-	-	-	803	1.14	834	1.24	864	1.36	894	1.48	922	1.59	948	1.70	975	1.82	1001	1.95	1028	2.09	1053	2.23	-	-
8160	803	1.21	833	1.31	861	1.42	887	1.52	916	1.64	945	1.77	972	1.90	997	2.02	1022	2.14	1046	2.27	1071	2.41	1095	2.55	-	-

		325		350		375		400		425		450		475		500	
m ³ /h	Fan RPM	kW	Fan RPM	kW	Fan RPM	kW	Fan RPM	kW	Fan RPM	kW	Fan RPM	kW	Fan RPM	kW	Fan RPM	kW	
5440	973	1.60	999	1.72	1024	1.84	1048	1.97	1072	2.10	1095	2.23	1117	2.37	1140	2.51	
6120	1007	1.82	1033	1.94	1059	2.07	1082	2.20	1107	2.34	1130	2.49	1152	2.63	1173	2.77	
6800	1042	2.08	1068	2.21	1093	2.35	1117	2.48	1142	2.63	1164	2.76	1187	2.91	1209	3.06	
7480	1078	2.38	1103	2.52	1128	2.66	1152	2.81	1176	2.95	1198	3.10	1221	3.25	-	-	
8160	1119	2.70	1142	2.86	1166	3.02	1189	3.17	1212	3.33	-	-	-	-	-	-	

Table 19 - TSH 120 Available static pressure

External Static Pressure (Pa)																									
		25		50		75		100		125		150		175		200		225		250		275		300	
m ³ /h	RPM	kW	RPM	kW	RPM	kW	RPM	kW	RPM	kW	RPM	kW	RPM	kW	RPM	kW	RPM	kW	RPM	kW	Fan RPM	kW	Fan RPM	kW	
5440	-	-	-	-	-	-	-	-	807	0.94	844	1.04	886	1.16	926	1.28	965	1.41	1000	1.53	1029	1.64	1057	1.75	
6120	-	-	-	-	792	0.99	829	1.08	865	1.19	898	1.30	930	1.41	965	1.53	1002	1.67	1038	1.81	1072	1.95	1106	2.10	
6800	802	1.13	833	1.22	860	1.29	890	1.38	923	1.50	956	1.62	986	1.73	1015	1.85	1044	1.98	1077	2.12	1111	2.28	1143	2.43	
7480	876	1.49	905	1.58	931	1.67	955	1.75	983	1.86	1014	1.99	1045	2.12	1072	2.25	1098	2.37	1125	2.51	1152	2.65	1182	2.81	
8160	950	1.91	977	2.02	1002	2.11	1025	2.20	1048	2.30	1074	2.42	1102	2.56	1131	2.71	1156	2.84	1181	2.98	1205	3.12	1229	3.27	

		325		350		375		400		425		450		475		500	
m ³ /h	Fan RPM	kW	Fan RPM	kW	Fan RPM	kW	Fan RPM	kW	Fan RPM	kW	Fan RPM	kW	Fan RPM	kW	Fan RPM	kW	
5440	1084	1.86	1108	1.96	1132	2.06	1155	2.17	1177	2.27	1198	2.37	1219	2.48	1239	2.58	
6120	1134	2.22	1160	2.35	1185	2.47	1209	2.59	1231	2.70	1252	2.82	1274	2.94	1295	3.06	
6800	1174	2.58	1204	2.74	1232	2.90	1260	3.05	1283	3.18	1306	3.32	-	-	-	-	
7480	1211	2.97	1241	3.14	1270	3.31	-	-	-	-	-	-	-	-	-	-	
8160	-	-	-	-	-	-	-	-	-	-	-	-	-	-	-	-	

Standard drive
 Oversize drive

Note: Data includes pressure drops for standard filters and wet coils

Installation

Table 20 - YSD 060 Available static pressure

External Static Pressure (Pa)																												
		25		50		75		100		125		150		175		200		225		250		275		300				
m ² /h	RPM	kW	RPM	kW	RPM	kW	RPM	kW	RPM	kW	RPM	kW	RPM	kW	RPM	kW	RPM	kW	RPM	kW	Fan RPM	kW	Fan RPM	kW				
2720	-	-	-	-	-	-	-	-	-	-	-	-	-	-	-	-	1043	0.62	1078	0.67	1113	0.72	1145	0.77	1177	0.82		
3060	-	-	-	-	-	-	-	-	-	-	-	-	-	-	-	-	1066	0.70	1103	0.76	1137	0.82	1169	0.87	1202	0.93	1232	0.98
3400	-	-	-	-	-	-	-	-	-	1052	0.73	1089	0.79	1126	0.85	1162	0.92	1196	0.98	1229	1.05	1260	1.11	1289	1.17	-	-	
3740	-	-	-	-	1051	0.82	1087	0.87	1122	0.92	1156	0.98	1190	1.03	1224	1.10	1257	1.17	1288	1.24	1320	1.32	-	-	-	-		
4080	1055	0.90	1093	0.97	1127	1.03	1160	1.09	1193	1.15	1225	1.20	1256	1.26	1288	1.32	-	-	-	-	-	-	-	-	-	-		

		325		350		375	
m ² /h	Fan RPM	kW	Fan RPM	kW	Fan RPM	kW	Fan RPM
2720	1208	0.87	1238	0.93	1268	0.98	-
3060	1262	1.04	1290	1.09	1319	1.15	-
3400	1319	1.24	1347	1.30	-	-	-
3740	-	-	-	-	-	-	-
4080	-	-	-	-	-	-	-

Table 21 - YSH 060 Available static pressure

External Static Pressure (Pa)																									
		25		50		75		100		125		150		175		200		225		250		275		300	
m ² /h	RPM	kW	RPM	kW	RPM	kW	RPM	kW	RPM	kW	RPM	kW	RPM	kW	RPM	kW	RPM	kW	RPM	kW	Fan RPM	kW	Fan RPM	kW	
2720	-	-	-	-	-	-	-	-	-	-	-	1069	0.63	1111	0.68	1151	0.74	1189	0.80	1225	0.87	1260	0.93	1293	0.99
3060	-	-	-	-	-	-	-	1056	0.66	1100	0.73	1141	0.79	1180	0.85	1218	0.92	1255	0.98	1290	1.05	1324	1.12	1357	1.19
3400	-	-	1033	0.70	1083	0.77	1131	0.84	1176	0.91	1216	0.98	1253	1.05	1289	1.13	1323	1.20	1357	1.27	-	-	-	-	-
3740	1072	0.83	1117	0.90	1163	0.98	1209	1.06	1251	1.14	1292	1.21	1329	1.29	-	-	-	-	-	-	-	-	-	-	-
4080	1161	1.06	1203	1.14	1245	1.23	1287	1.31	-	-	-	-	-	-	-	-	-	-	-	-	-	-	-	-	-

		325		350		375	
m ² /h	Fan RPM	kW	Fan RPM	kW	Fan RPM	kW	Fan RPM
2720	1324	1.06	1355	1.13	1383	1.20	-
3060	1390	1.26	-	-	-	-	-
3400	-	-	-	-	-	-	-
3740	-	-	-	-	-	-	-
4080	-	-	-	-	-	-	-

	Standard drive
	Oversize drive

Note: Data includes pressure drops for standard filters and wet coils



Installation

Table 22 - YSD 072 Available static pressure

External Static Pressure (Pa)																										
		25		50		75		100		125		150		175		200		225		250		275		300		
m ² /h	RPM	kW	RPM	kW	RPM	kW	RPM	kW	RPM	kW	RPM	kW	RPM	kW	RPM	kW	RPM	kW	RPM	kW	Fan RPM	kW	Fan RPM	kW		
3260	-	-	-	-	-	-	-	-	-	-	-	-	-	-	820	0.54	859	0.60	896	0.66	932	0.72	968	0.78	1000	0.84
3670	-	-	-	-	-	-	-	-	-	-	-	814	0.58	854	0.64	891	0.71	928	0.78	963	0.84	996	0.91	1028	0.98	
4080	-	-	-	-	-	-	-	-	-	814	0.64	853	0.70	890	0.77	926	0.84	961	0.91	994	0.98	1027	1.05	1058	1.13	
4490	-	-	-	-	-	-	815	0.70	857	0.77	894	0.84	929	0.91	963	0.98	996	1.06	1028	1.14	1060	1.22	1090	1.29		
4890	-	-	-	-	818	0.77	860	0.85	899	0.93	936	1.01	970	1.08	1003	1.16	1035	1.24	1066	1.32	1096	1.40	1125	1.48		

		325		350		375	
m ² /h	Fan RPM	kW	Fan RPM	kW	Fan RPM	kW	
3260	1033	0.90	1063	0.96	1094	1.03	
3670	1061	1.05	1091	1.12	1121	1.18	
4080	1090	1.21	1118	1.28	1149	1.36	
4490	1120	1.38	1150	1.46	1178	1.54	
4890	1155	1.57	1181	1.66	1210	1.75	

Table 23 - YSH 072 Available static pressure

External Static Pressure (Pa)																									
		25		50		75		100		125		150		175		200		225		250		275		300	
m ² /h	RPM	kW	RPM	kW	RPM	kW	RPM	kW	RPM	kW	RPM	kW	RPM	kW	RPM	kW	RPM	kW	RPM	kW	Fan RPM	kW	Fan RPM	kW	
3260	-	-	-	-	-	-	-	-	-	-	-	824	0.52	866	0.59	907	0.65	947	0.71	986	0.78	1023	0.84	1059	0.92
3670	-	-	-	-	-	-	-	-	-	826	0.57	865	0.64	903	0.71	943	0.78	979	0.84	1017	0.91	1053	0.98	1087	1.06
4080	-	-	-	-	-	-	836	0.64	874	0.70	911	0.77	947	0.84	982	0.92	1017	1.00	1051	1.07	1085	1.15	1119	1.23	
4490	-	-	-	-	847	0.72	888	0.80	924	0.86	959	0.93	993	1.00	1026	1.08	1058	1.17	1089	1.25	1122	1.34	1153	1.42	
4890	818	0.74	858	0.81	900	0.88	940	0.97	977	1.05	1010	1.13	1042	1.20	1073	1.27	1104	1.36	1133	1.45	1163	1.54	1192	1.64	

		325		350		375	
m ² /h	Fan RPM	kW	Fan RPM	kW	Fan RPM	kW	
3260	1093	0.98	1126	1.06	1156	1.12	
3670	1121	1.13	1153	1.21	1185	1.29	
4080	1151	1.30	1182	1.38	1214	1.47	
4490	1184	1.50	1215	1.59	-	-	
4890	1221	1.72	-	-	-	-	

Standard drive
 Oversize drive

Note: Data includes pressure drops for standard filters and wet coils

Installation

Table 24 - YSD 090 Available static pressure

External Static Pressure (Pa)																										
		25		50		75		100		125		150		175		200		225		250		275		300		
m ³ /h	RPM	kW	RPM	kW	RPM	kW	RPM	kW	RPM	kW	RPM	kW	RPM	kW	RPM	kW	RPM	kW	RPM	kW	Fan RPM	kW	Fan RPM	kW		
4080	-	-	-	-	-	-	-	-	-	-	-	-	869	0.73	906	0.80	941	0.87	976	0.94	1009	1.01	1042	1.09	1073	1.17
4590	-	-	-	-	-	-	-	-	-	887	0.85	922	0.92	958	0.99	991	1.07	1024	1.14	1055	1.22	1086	1.30	1117	1.39	
5100	-	-	-	-	865	0.89	905	0.98	943	1.06	979	1.15	1012	1.23	1044	1.31	1075	1.39	1105	1.47	1134	1.56	1163	1.65		
5610	858	0.97	894	1.05	929	1.13	965	1.22	1001	1.32	1036	1.41	1068	1.50	1099	1.59	1129	1.68	1157	1.77	1185	1.86	1212	1.95		
6120	930	1.24	963	1.33	995	1.42	1028	1.51	1061	1.61	1093	1.71	1126	1.82	1157	1.92	1185	2.02	1212	2.11	1239	2.21	1265	2.31		

		325		350		375	
m ³ /h	Fan RPM	kW	Fan RPM	kW	Fan RPM	kW	
4080	1104	1.24	1134	1.32	1163	1.40	
4590	1146	1.47	1174	1.56	1203	1.65	
5100	1191	1.74	1218	1.83	1245	1.92	
5610	1238	2.04	1265	2.14	1292	2.24	
6120	1290	2.40	1316	2.51	1340	2.61	

Table 25 - YSH 090 Available static pressure

External Static Pressure (Pa)																									
		25		50		75		100		125		150		175		200		225		250		275		300	
m ³ /h	RPM	kW	RPM	kW	RPM	kW	RPM	kW	RPM	kW	RPM	kW	RPM	kW	RPM	kW	RPM	kW	RPM	kW	Fan RPM	kW	Fan RPM	kW	
4080	-	-	-	-	-	-	851	0.67	889	0.73	926	0.80	962	0.88	997	0.95	1031	1.03	1067	1.11	1101	1.19	1134	1.26	
4590	-	-	-	-	880	0.80	919	0.88	955	0.94	989	1.01	1022	1.09	1054	1.17	1086	1.26	1117	1.35	1148	1.43	1180	1.52	
5100	869	0.87	910	0.94	950	1.03	989	1.12	1023	1.21	1056	1.28	1086	1.36	1116	1.43	1146	1.52	1175	1.62	1204	1.72	1232	1.81	
5610	949	1.14	985	1.22	1023	1.30	1058	1.40	1092	1.51	1124	1.60	1154	1.68	1182	1.77	1210	1.85	1237	1.94	1264	2.04	1290	2.14	
6120	1029	1.47	1061	1.55	1096	1.64	1130	1.74	1162	1.85	1193	1.96	1222	2.06	1250	2.16	1276	2.25	1302	2.34	1327	2.43	1352	2.53	

		325		350		375	
m ³ /h	Fan RPM	kW	Fan RPM	kW	Fan RPM	kW	
4080	1166	1.34	1197	1.42	1229	1.50	
4590	1210	1.60	1241	1.69	1269	1.78	
5100	1260	1.91	1287	2.00	1316	2.10	
5610	1316	2.25	1342	2.36	1367	2.46	
6120	1376	2.64	1401	2.75	1425	2.87	

	Standard drive
	Override drive

Note: Data includes pressure drops for standard filters and wet coils



Installation

Table 26 - YSD 102 Available static pressure

External Static Pressure (Pa)																										
		25		50		75		100		125		150		175		200		225		250		275		300		
m ³ /h	RPM	kW	RPM	kW	RPM	kW	RPM	kW	RPM	kW	RPM	kW	RPM	kW	RPM	kW	RPM	kW	RPM	kW	Fan RPM	kW	Fan RPM	kW		
4620	-	-	-	-	-	-	-	-	-	-	-	-	-	-	787	0.85	819	0.96	850	1.06	879	1.17	907	1.27	934	1.39
5200	-	-	-	-	-	-	-	-	-	-	-	-	794	0.92	827	1.02	859	1.13	890	1.23	918	1.34	946	1.46	971	1.58
5780	-	-	-	-	-	-	-	-	-	805	1.00	837	1.11	869	1.22	900	1.33	929	1.44	959	1.56	986	1.68	1011	1.80	
6350	-	-	-	-	792	1.00	823	1.10	854	1.21	884	1.33	914	1.45	943	1.57	971	1.69	999	1.81	1025	1.94	1051	2.06		
6930	786	1.03	818	1.14	848	1.24	877	1.34	905	1.46	933	1.58	961	1.71	988	1.84	1015	1.97	1041	2.10	1067	2.23	1092	2.36		

		325		350		375		400		425		450		475		500	
m ³ /h	Fan RPM	kW	Fan RPM	kW	Fan RPM	kW	Fan RPM	kW	Fan RPM	kW	Fan RPM	kW	Fan RPM	kW	Fan RPM	kW	
4620	960	1.50	987	1.62	1013	1.73	1038	1.85	1064	1.97	1087	2.09	1111	2.21	1134	2.34	
5200	997	1.70	1023	1.83	1047	1.95	1070	2.08	1094	2.21	1117	2.34	1140	2.47	1163	2.60	
5780	1037	1.93	1061	2.06	1085	2.19	1107	2.33	1130	2.46	1151	2.60	1174	2.75	1194	2.88	
6350	1077	2.19	1100	2.32	1123	2.46	1147	2.61	1168	2.75	1189	2.89	1211	3.04	1231	3.19	
6930	1117	2.50	1140	2.64	1164	2.78	1187	2.92	1208	3.07	1229	3.22	-	-	-	-	

Table 27 - YSH 102 Available static pressure

External Static Pressure (Pa)																									
		25		50		75		100		125		150		175		200		225		250		275		300	
m ³ /h	RPM	kW	RPM	kW	RPM	kW	RPM	kW	RPM	kW	RPM	kW	RPM	kW	RPM	kW	RPM	kW	RPM	kW	Fan RPM	kW	Fan RPM	kW	
4620	-	-	-	-	-	-	787	0.79	831	0.89	869	0.99	901	1.08	931	1.17	959	1.26	986	1.35	1011	1.43	1036	1.52	
5200	-	-	-	-	798	0.88	841	1.00	883	1.11	923	1.23	958	1.35	989	1.45	1017	1.55	1045	1.65	1070	1.75	1094	1.85	
5780	793	0.94	830	1.04	863	1.14	898	1.25	937	1.37	975	1.51	1011	1.64	1045	1.77	1075	1.89	1103	2.01	1128	2.12	1152	2.23	
6350	865	1.23	899	1.34	930	1.45	961	1.56	994	1.68	1028	1.82	1063	1.96	1097	2.11	1129	2.26	1159	2.40	1186	2.53	1210	2.65	
6930	937	1.57	970	1.70	999	1.81	1027	1.93	1055	2.05	1085	2.19	1118	2.34	1150	2.50	1181	2.66	1211	2.82	1239	2.97	1267	3.13	

		325		350		375		400		425		450		475		500	
m ³ /h	Fan RPM	kW	Fan RPM	kW	Fan RPM	kW	Fan RPM	kW	Fan RPM	kW	Fan RPM	kW	Fan RPM	kW	Fan RPM	kW	
4620	1059	1.61	1082	1.69	1104	1.78	1127	1.87	1149	1.96	1170	2.05	1191	2.14	1212	2.24	
5200	1117	1.95	1139	2.05	1161	2.15	1182	2.24	1203	2.35	1222	2.44	1243	2.54	1262	2.64	
5780	1176	2.34	1198	2.45	1219	2.56	1241	2.67	1261	2.78	1280	2.88	1299	2.99	1319	3.11	
6350	1233	2.78	1256	2.90	1278	3.03	1298	3.15	1319	3.27	-	-	-	-	-	-	
6930	1291	3.27	-	-	-	-	-	-	-	-	-	-	-	-	-	-	

Standard drive
 Oversize drive

Note: Data includes pressure drops for standard filters and wet coils

Installation

Table 28 - YSD 120 Available static pressure

External Static Pressure (Pa)																										
		25		50		75		100		125		150		175		200		225		250		275		300		
m ³ /h	RPM	kW	RPM	kW	RPM	kW	RPM	kW	RPM	kW	RPM	kW	RPM	kW	RPM	kW	RPM	kW	RPM	kW	Fan RPM	kW	Fan RPM	kW		
5440	-	-	-	-	-	-	-	-	-	-	-	-	-	-	-	-	891	1.26	921	1.37	949	1.49	976	1.61	1001	1.73
6120	-	-	-	-	-	-	-	-	-	-	-	-	-	-	913	1.42	942	1.54	971	1.66	999	1.78	1025	1.90	1052	2.03
6800	-	-	-	-	-	-	-	-	-	913	1.48	941	1.60	969	1.73	997	1.86	1024	1.99	1050	2.12	1076	2.26	1101	2.39	
7480	-	-	895	1.48	923	1.59	949	1.70	976	1.83	1003	1.96	1029	2.10	1054	2.24	1079	2.38	1104	2.53	1129	2.67	1153	2.81		
8160	939	1.75	967	1.87	992	1.99	1017	2.12	1042	2.24	1066	2.38	1090	2.52	1114	2.67	1138	2.83	1161	2.98	1184	3.14	1207	3.30		

		325		350		375		400		425		450		475		500	
m ³ /h	Fan RPM	kW	Fan RPM	kW	Fan RPM	kW	Fan RPM	kW	Fan RPM	kW	Fan RPM	kW	Fan RPM	kW	Fan RPM	kW	
5440	1027	1.86	1051	1.99	1075	2.12	1098	2.25	1120	2.38	1143	2.52	1166	2.66	1189	2.80	
6120	1076	2.17	1100	2.30	1122	2.44	1145	2.58	1167	2.73	1188	2.87	1210	3.02	1230	3.17	
6800	1126	2.53	1149	2.67	1172	2.81	1194	2.96	1216	3.12	1236	3.26	-	-	-	-	
7480	1176	2.96	1200	3.11	1222	3.26	-	-	-	-	-	-	-	-	-	-	
8160	-	-	-	-	-	-	-	-	-	-	-	-	-	-	-	-	

Table 29 - YSH 120 Available static pressure

External Static Pressure (Pa)																									
		25		50		75		100		125		150		175		200		225		250		275		300	
m ³ /h	RPM	kW	RPM	kW	RPM	kW	RPM	kW	RPM	kW	RPM	kW	RPM	kW	RPM	kW	RPM	kW	RPM	kW	Fan RPM	kW	Fan RPM	kW	
5440	-	-	-	-	-	-	-	-	-	924	1.28	962	1.40	998	1.52	1028	1.64	1055	1.74	1082	1.85	1107	1.95	1131	2.06
6120	-	-	-	-	921	1.37	955	1.49	992	1.63	1028	1.77	1063	1.91	1096	2.05	1126	2.19	1153	2.31	1178	2.43	1202	2.55	
6800	943	1.57	973	1.68	1002	1.80	1031	1.92	1062	2.06	1096	2.21	1129	2.36	1161	2.52	1192	2.68	1222	2.84	1249	2.99	1273	3.13	
7480	1031	2.06	1060	2.19	1086	2.32	1113	2.45	1139	2.57	1167	2.73	1198	2.90	1228	3.07	1257	3.24	-	-	-	-	-	-	
8160	1119	2.58	1146	2.79	1171	2.93	1195	3.07	1219	3.21	1243	3.36	-	-	-	-	-	-	-	-	-	-	-	-	

		325		350		375		400		425		450		475		500	
m ³ /h	Fan RPM	kW	Fan RPM	kW	Fan RPM	kW	Fan RPM	kW	Fan RPM	kW	Fan RPM	kW	Fan RPM	kW	Fan RPM	kW	
5440	1154	2.16	1176	2.27	1197	2.37	1218	2.47	1238	2.58	1257	2.68	1276	2.78	1296	2.89	
6120	1224	2.67	1247	2.79	1268	2.91	1288	3.02	1308	3.14	1328	3.26	-	-	-	-	
6800	1296	3.26	-	-	-	-	-	-	-	-	-	-	-	-	-	-	
7480	-	-	-	-	-	-	-	-	-	-	-	-	-	-	-	-	
8160	-	-	-	-	-	-	-	-	-	-	-	-	-	-	-	-	

Standard drive
 Oversize drive

Note: Data includes pressure drops for standard filters and wet coils



Installation

Table 30 - WSD 060 Available static pressure

External Static Pressure (Pa)																										
		25		50		75		100		125		150		175		200		225		250		275		300		
m ² /h	RPM	kW	RPM	kW	RPM	kW	RPM	kW	RPM	kW	RPM	kW	RPM	kW	RPM	kW	RPM	kW	RPM	kW	Fan RPM	kW	Fan RPM	kW		
2720	-	-	-	-	-	-	-	-	-	-	-	-	-	-	933	0.47	975	0.53	1014	0.58	1050	0.63	1085	0.68	1118	0.72
3060	-	-	-	-	-	-	-	-	892	0.48	935	0.52	976	0.57	1016	0.62	1056	0.68	1093	0.74	1128	0.80	1160	0.86		
3400	-	-	-	-	-	-	904	0.55	945	0.60	985	0.65	1023	0.70	1061	0.75	1098	0.80	1135	0.86	1170	0.93	1203	1.00		
3740	-	-	-	-	913	0.63	959	0.68	1001	0.74	1038	0.80	1074	0.85	1109	0.90	1143	0.96	1177	1.01	1212	1.07	1244	1.14		
4080	-	-	933	0.74	972	0.78	1014	0.84	1056	0.90	1094	0.97	1128	1.03	1160	1.09	1193	1.15	1225	1.20	1256	1.26	1287	1.32		

		325		350		375	
m ² /h	Fan RPM	kW	Fan RPM	kW	Fan RPM	kW	
2720	1151	0.78	1183	0.83	1214	0.88	
3060	1192	0.91	1223	0.97	1252	1.02	
3400	1235	1.06	1265	1.12	1295	1.19	
3740	1276	1.21	1308	1.29	-	-	
4080	-	-	-	-	-	-	

Table 31 - WSH 060 Available static pressure

External Static Pressure (Pa)																									
		25		50		75		100		125		150		175		200		225		250		275		300	
m ² /h	RPM	kW	RPM	kW	RPM	kW	RPM	kW	RPM	kW	RPM	kW	RPM	kW	RPM	kW	RPM	kW	RPM	kW	Fan RPM	kW	Fan RPM	kW	
2720	-	-	-	-	-	-	-	-	941	0.47	990	0.52	1034	0.58	1077	0.64	1119	0.70	1158	0.75	1196	0.82	1231	0.88	
3060	-	-	-	-	-	-	937	0.52	992	0.58	1043	0.65	1088	0.71	1130	0.77	1169	0.83	1207	0.90	1244	0.96	1280	1.03	
3400	-	-	-	-	945	0.58	995	0.65	1045	0.72	1094	0.79	1141	0.86	1185	0.93	1224	1.00	1260	1.07	1295	1.14	1330	1.21	
3740	901	0.60	958	0.67	1009	0.73	1057	0.80	1101	0.88	1146	0.95	1192	1.03	1235	1.11	1277	1.18	1314	1.26	-	-	-	-	
4080	973	0.76	1026	0.84	1075	0.91	1120	0.98	1163	1.06	1204	1.14	1245	1.23	-	-	-	-	-	-	-	-	-	-	

		325		350		375	
m ² /h	Fan RPM	kW	Fan RPM	kW	Fan RPM	kW	
2720	1265	0.94	1298	1.00	1330	1.07	
3060	1314	1.10	1346	1.16	1380	1.24	
3400	1363	1.28	-	-	-	-	
3740	-	-	-	-	-	-	
4080	-	-	-	-	-	-	

Standard drive
 Oversize drive

Note: Data includes pressure drops for standard filters and wet coils

Installation

Table 32 - WSD 072 Available static pressure

External Static Pressure (Pa)																									
		25		50		75		100		125		150		175		200		225		250		275		300	
m ³ /h	RPM	kW	RPM	kW	RPM	kW	RPM	kW	RPM	kW	RPM	kW	RPM	kW	RPM	kW	RPM	kW	RPM	kW	Fan RPM	kW	Fan RPM	kW	
3260	-	-	-	-	-	-	-	-	-	705	0.38	751	0.44	794	0.50	835	0.56	874	0.62	912	0.68	948	0.75	982	0.81
3670	-	-	-	-	-	-	-	-	-	736	0.47	779	0.53	821	0.59	860	0.65	898	0.72	936	0.79	971	0.86	1004	0.93
4080	-	-	-	-	-	-	720	0.50	768	0.56	810	0.63	850	0.70	888	0.76	925	0.83	961	0.91	995	0.98	1027	1.06	
4490	-	-	-	-	709	0.53	753	0.60	799	0.67	843	0.75	882	0.82	919	0.89	954	0.97	987	1.04	1021	1.12	1053	1.20	
4890	-	-	705	0.58	749	0.64	791	0.72	832	0.79	874	0.88	914	0.96	950	1.04	985	1.12	1018	1.20	1050	1.28	1081	1.36	

		325		350		375	
m ³ /h	Fan RPM	kW	Fan RPM	kW	Fan RPM	kW	
3260	1015	0.87	1047	0.93	1079	0.99	
3670	1037	1.00	1069	1.07	1099	1.14	
4080	1060	1.13	1091	1.21	1121	1.29	
4490	1085	1.28	1115	1.36	1145	1.45	
4890	1112	1.44	1140	1.53	1170	1.62	

Table 33 - WSH 072 Available static pressure

External Static Pressure (Pa)																										
		25		50		75		100		125		150		175		200		225		250		275		300		
m ³ /h	RPM	kW	RPM	kW	RPM	kW	RPM	kW	RPM	kW	RPM	kW	RPM	kW	RPM	kW	RPM	kW	RPM	kW	RPM	kW	Fan RPM	kW	Fan RPM	kW
3260	-	-	-	-	-	-	-	-	-	750	0.42	794	0.48	838	0.55	882	0.61	923	0.67	963	0.73	1002	0.80	1038	0.87	
3670	-	-	-	-	695	0.40	745	0.46	789	0.51	830	0.58	871	0.65	910	0.72	950	0.79	987	0.86	1025	0.93	1060	1.00		
4080	-	-	-	-	737	0.49	787	0.57	831	0.64	870	0.70	908	0.76	944	0.84	980	0.92	1015	0.99	1051	1.07	1085	1.15		
4490	-	-	740	0.55	781	0.61	828	0.68	872	0.77	911	0.84	948	0.91	983	0.98	1016	1.06	1049	1.14	1081	1.23	1113	1.31		
4890	761	0.64	795	0.70	828	0.76	871	0.83	913	0.91	953	1.00	990	1.08	1023	1.15	1055	1.23	1086	1.31	1117	1.40	1147	1.49		

		325		350		375	
m ³ /h	Fan RPM	kW	Fan RPM	kW	Fan RPM	kW	
3260	1073	0.94	1107	1.01	1140	1.09	
3670	1096	1.07	1129	1.15	1162	1.23	
4080	1118	1.23	1152	1.31	1185	1.39	
4490	1146	1.40	1178	1.49	1208	1.57	
4890	1178	1.59	1206	1.68	1236	1.77	

	Standard drive
	Oversize drive

Note: Data includes pressure drops for standard filters and wet coils



Installation

Table 34 - WSD 090 Available static pressure

m ³ /h	External Static Pressure (Pa)																								
	25		50		75		100		125		150		175		200		225		250		275		300		
	RPM	kW	RPM	kW	RPM	kW	RPM	kW	RPM	kW	RPM	kW	RPM	kW	RPM	kW	RPM	kW	RPM	kW	Fan RPM	kW	Fan RPM	kW	
4080	-	-	-	-	-	-	-	-	-	768	0.56	810	0.63	850	0.70	888	0.76	925	0.83	961	0.91	995	0.98	1027	1.06
4590	-	-	-	-	-	-	763	0.63	807	0.70	850	0.78	889	0.85	926	0.93	961	1.00	995	1.08	1027	1.15	1059	1.23	
5100	-	-	-	-	770	0.71	810	0.78	849	0.86	890	0.95	929	1.03	967	1.12	1000	1.20	1034	1.28	1065	1.36	1095	1.45	
5610	-	-	782	0.83	823	0.90	861	0.97	897	1.05	933	1.12	969	1.23	1006	1.33	1041	1.42	1074	1.52	1104	1.60	1134	1.70	
6120	798	0.94	838	1.04	876	1.12	913	1.20	947	1.28	980	1.37	1013	1.47	1047	1.57	1080	1.67	1113	1.77	1144	1.88	1173	1.98	

m ³ /h	325		350		375	
	Fan RPM	kW	Fan RPM	kW	Fan RPM	kW
4080	1060	1.13	1091	1.21	1121	1.29
4590	1091	1.32	1121	1.40	1151	1.49
5100	1125	1.53	1154	1.62	1183	1.71
5610	1163	1.79	1191	1.88	1217	1.97
6120	1202	2.08	1229	2.17	1256	2.27

Table 35 - WSH 090 Available static pressure

m ³ /h	External Static Pressure (Pa)																							
	25		50		75		100		125		150		175		200		225		250		275		300	
	RPM	kW	RPM	kW	RPM	kW	RPM	kW	RPM	kW	RPM	kW	RPM	kW	RPM	kW	RPM	kW	RPM	kW	Fan RPM	kW	Fan RPM	kW
4080	-	-	-	-	-	-	787	0.57	831	0.64	870	0.70	908	0.76	944	0.84	980	0.92	1015	0.99	1051	1.07	1085	1.15
4590	-	-	753	0.59	792	0.65	839	0.72	882	0.80	922	0.88	958	0.95	992	1.02	1026	1.10	1058	1.18	1090	1.27	1122	1.36
5100	789	0.71	822	0.78	853	0.84	892	0.91	935	0.99	974	1.08	1011	1.18	1044	1.25	1076	1.33	1106	1.41	1136	1.49	1165	1.59
5610	862	0.93	892	1.01	921	1.08	951	1.15	988	1.22	1026	1.31	1062	1.42	1096	1.52	1129	1.61	1158	1.69	1187	1.78	1214	1.86
6120	934	1.20	963	1.28	990	1.35	1016	1.43	1045	1.51	1079	1.59	1115	1.69	1148	1.80	1180	1.91	1210	2.02	1239	2.12	1266	2.21

m ³ /h	325		350		375	
	Fan RPM	kW	Fan RPM	kW	Fan RPM	kW
4080	1118	1.23	1152	1.31	1185	1.39
4590	1153	1.45	1185	1.53	1216	1.62
5100	1194	1.68	1223	1.78	1251	1.88
5610	1242	1.96	1269	2.06	1296	2.17
6120	1291	2.30	1317	2.39	1343	2.49

Standard drive
 Oversize drive

Note: Data includes pressure drops for standard filters and wet coils

Electrical Connection

The electric panel is located in the unit compressor section. Remove the compressor access panel. The unit is designed to run with 400V +/- 5%/50Hz/3ph.

Factory supplied disconnect switch (option)

The disconnect switch is factory mounted. It is located in the compressor section. Mount the disconnect switch onto the exterior of the unit, between the condenser coil and the electrical panel (near the unit top corner). Wire the disconnect switch from the power terminal block in the panel to the disconnect switch with the wire bundle provided by following the electrical diagram found in the unit.

Figure 13 - Power supply

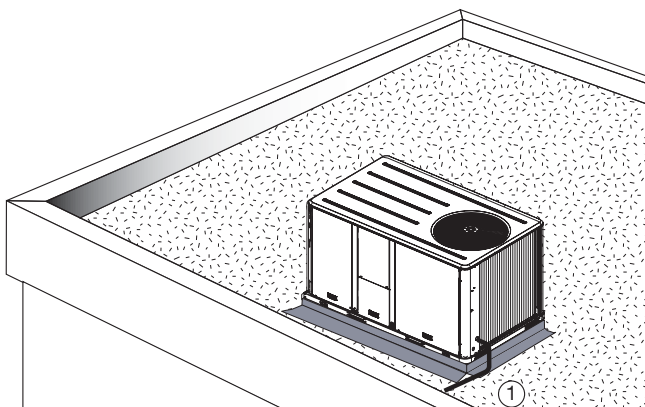

1 = Power supply

Over current protection

The branch circuit feeding the unit must be protected in accordance with national or local codes and maximum unit amps indicated in Table 36.

Power wiring

The unit's power supply must be provided by 4-wire cable with cross-sectional areas complying with legislation.

The power supply cables must be laid in leak-tight pipes and pass through the bottom of the electric panel for units without electric heaters and through the heat section when electric heater option is selected. The cables must not be taut.

Appropriate connectors must be provided. Flexible pipe supports are required to prevent noise transmission in the building's structure. Ensure all the connections are tightened.

Note:

1. Earthing must be executed in compliance to national and local legislation.
2. The machines are designed for a short-circuit current of 10kA. In the event of a higher application, contact your local sales office.

Compressor electrical phasing

Proper phasing of the electrical power wiring is critical for proper operation and reliability of the scroll compressor and fans.

Proper rotation of the scroll compressor must be established before the unit is started. This is accomplished by confirming that the electrical phase sequence of the power supply is correct. The motor is internally connected for clockwise rotation with the inlet power supply phased A,B,C.

The direction of rotation may be reversed by interchanging any two of the line wires. It is this possible interchange of wiring that makes a phase sequence indicator necessary if the operator is to quickly determine the phase rotation of the compressor motor.

The "ABC" indicator on the face of the phase indicator will glow if phase is ABC for terminals L1, L2, L3.

IMPORTANT! After completion of wiring, check all electrical connections, and ensure all connections are tight. Replace and secure all electrical box covers and access doors before leaving unit or connecting power to circuit supplying the unit.

CAUTION! Units with scroll compressors are not equipped with crankcase heaters.

WARNING! Disconnect all power, including remote disconnects, and discharge all capacitors before servicing.

Follow proper lockout/tagout procedures to ensure the power cannot be inadvertently energized. After power is removed, allow 4 minutes for capacitors to discharge. Verify with an appropriate voltmeter that all capacitors have discharged. Failure to disconnect power and/or discharge capacitors before servicing could result in death or serious injury. For additional information regarding the safe discharge of capacitors, see Trane Service Bulletin PROD-SVB06A



Installation

Table 36 - Electrical characteristics

Unit	Control	Compressor 1/2		Indoor Fan		Outdoor Fan		Electric Heat
		Max Amps	Max Amps	Start Amps	Standard drive	Oversized drive	Quantity	Max Amps
YSD/YSH/TSD/TSH 060	0.3	11.3	71	3.2		1	1.0	17.3
YSD/YSH/TSD/TSH 072	0.3	15.2	95	3.2	4.3	1	3.0	26
YSD/YSH/TSD/TSH 090	0.3	17.4	111	4.3	5.3	1	3.0	26
YSD/YSH/TSD/TSH 102	0.3	11.3	71/51	4.3	5.3	1	3.0	36.1
YSD/YSH/TSD/TSH 120	0.3	12.2	75/52	5.3		1	3.0	36.1
WSD/WSH 060	0.3	11.3	71	3.2		1	1.0	17.3
WSD/WSH 072	0.3	14.1	75	3.2	4.3	1	3.0	26
WSD/WSH 090	0.3	17.4	111	4.3	5.3	1	3.0	26

(3) For standard unit, without electric heat at 400V/3/50

(4) For standard unit, with electric heat at 400V/3/50

Data are subject to change without notice. Please refer to unit nameplate data.

CO₂ Sensors

Wall-mounted and duct-mounted CO₂ sensors

Power supply requirements

CAUTION! Make sure that you connect the power wire only to the 24V terminal. Connecting the power wire to the output terminal may result in equipment damage.

The CO₂ sensor is designed to operate with a nominal 24 Vac supply. The power supply should maintain the voltage between 20 to 26 Vac.

Table 38 - CO₂ sensor wire size

Wire size (mm ²)	Maximum wire length (m)
0.25	50
0.5	100
1	200

Table 37 - Specifications

	Wall-mounted		Duct-mounted
Measuring range CO ₂		0-2000 ppm	
Accuracy at 25°C	< +/- [40 ppm CO ₂ + 3% of reading] (included repeatability and calibration uncertainty)		< +/- [30 ppm CO ₂ + 2% of reading] (included repeatability and calibration uncertainty)
Non-linearity		< 1.0% full scale	
Temperature dependence of output		0.3% full scale/°C	
Long-term stability		< 5.0% full scale/ 5 years	
Recommended calibration interval		5 years	
Response time		1 minute (0-63%)	
Operating temperature	15-35°C		-5-45°C
Storage temperature		-20-70°C	
Humidity range		0-85% relative humidity	
Airflow range			0-10 m/s)
Output signals (jumper selectable)		0-10 Vdc	
Resolution of analog outputs		10 ppm CO ₂	
Recommended external load		Current output: max 500 Voltage output: min. 1000	
Power supply		Nominal 24 Vac	
Power consumption		< 5 VA	
Warm-up time		< 15 minutes	
Dimensions (mm)	108x80x36		80x80x200

Controls

Wiring the wall-mounted CO₂ sensor

DVC setpoint potentiometer on economizer module can be adjusted as follows:

0% - 500ppm, 50% - 1000 ppm,

100% - 1500ppm

The outside air damper will modulate from minimum position setting to up to 100% while attempting to maintain the CO₂ setpoint.

Wiring the duct-mounted CO₂ sensor

1. Connect the common wire from the controller to the ground terminal (terminal 0) (Figure below).
2. For voltage output, connect the signal wire to terminal V.
3. Connect the power according to the guidelines in Power supply requirements.

Figure 14 - Wall-mounted CO₂ sensor wiring

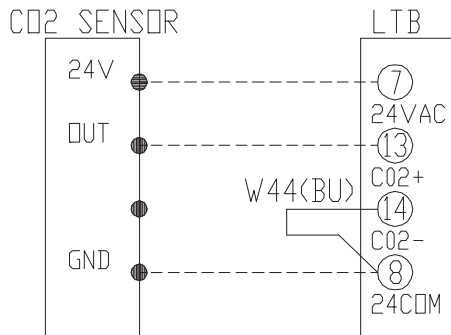
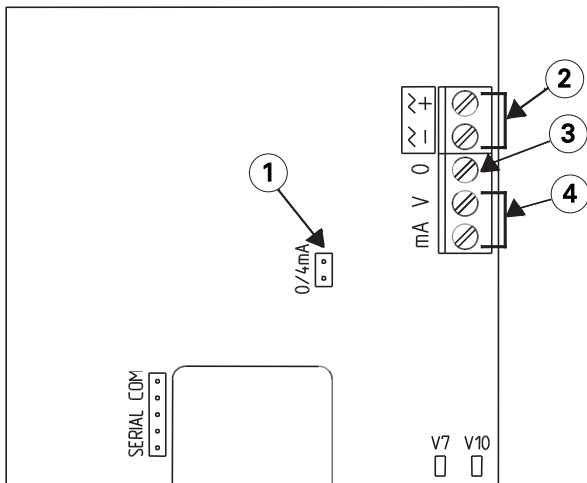

Figure 15 - Terminal connections and LED locations



- 1 = Outer jumper
- 2 = Power terminal
- 3 = Ground terminal
- 4 = Output terminals

Mounting the wall-mounted sensor

1. Select a proper location in the room to mount the CO₂ sensor. Look for an interior wall with good air circulation, approximately 1.4 m from the floor.
2. Remove the back plate from the sensor and thread the power wires and output signal wire through the hole in the back plate (Figure 16).
For surface wiring, make cut-outs with pliers to the thinner section of the upper or lower edge of the back plate and to thread the wires through.
3. Mount the back plate to the wall with screws. Note that the arrow on the back plate shows the mounting direction.
4. On the circuit board, use the two jumpers next to the terminal block to set up the type of output (0-10 Vdc) (Figure below).
5. Insert the circuit board in the back plate. (Figure 18.) Do not press the metal tube while inserting the circuit board.
6. Connect the power and signal wires to the screw terminals of the circuit board. Figure 15 shows the terminal locations.

Figure 16 - Wall-mounted CO₂ sensor

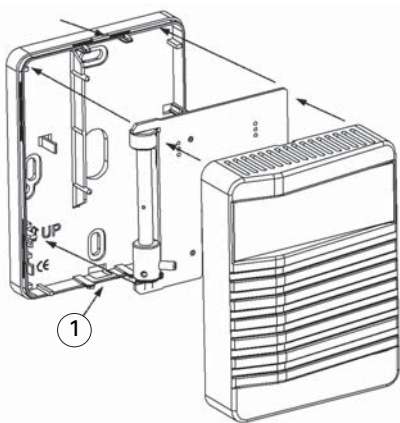

1 = Thinner section for cut-out

Figure 17 - Jumper settings

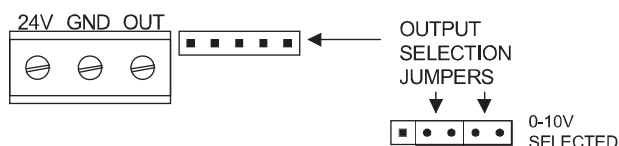

Mounting the duct-mounted CO₂ sensor

1. Select a proper location on the duct to mount the CO₂ sensor.
2. Drill a 22-25mm hole in the mounting surface for sensor insertion (Figure 18).
3. Attach the mounting plate to the duct wall with four screws.
4. Insert the sensor through the mounting plate, adjusting the depth for optimal air sensing.

Figure 18 - Duct-mounted CO₂ sensor diameter

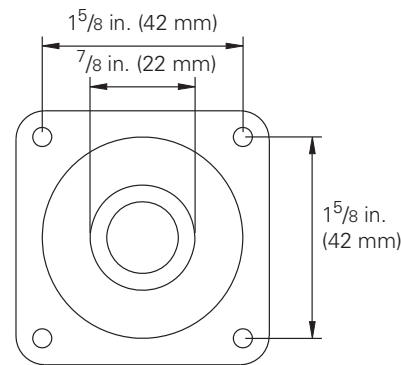

CO₂ sensor maintenance

This CO₂ sensor has excellent stability and requires no maintenance. In most environments the recommended calibration interval is five years. A trained service technician can use a portable CO₂ meter to certify sensor calibration. If, when checking the sensor, the reading differs too much from the reference value, the sensor can be recalibrated in the field. A calibration kit, software, and calibration gases are required. If certified accuracy is required, the sensor must be calibrated against accurate and traceable calibration gases in a laboratory. Consult Trane BAS for further details.

Figure 19 - Duct-mounted CO₂ sensor insertion depth

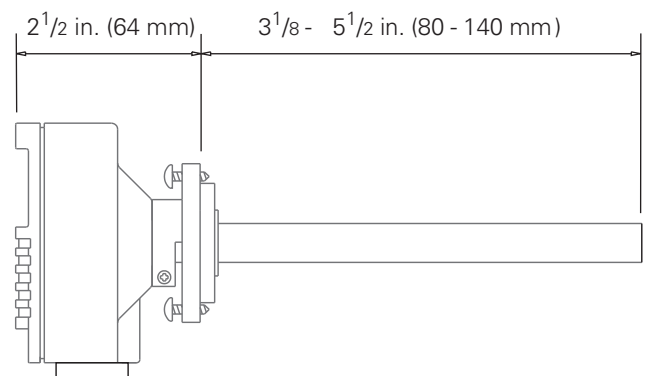

Controls

Remote Potentiometer

To install the remote potentiometer, cut the jumper WL on the economizer ECA board, and connect the wires to J11 and J12.

Note: This potentiometer allows to adjust the permanent fresh air intake from 0 to 50%.

0 W corresponds to closed fresh air damper.

270 W corresponds to 50% open fresh air damper.

Figure 20 - Remote potentiometer dimensions

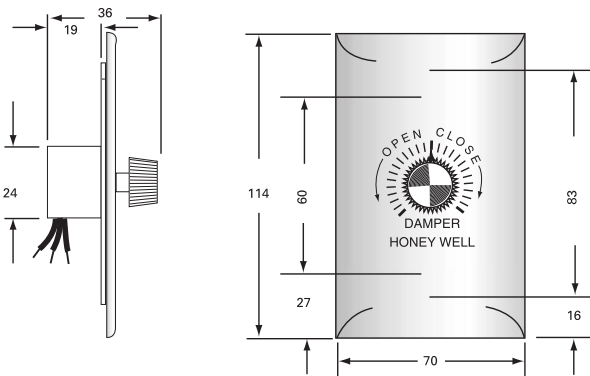
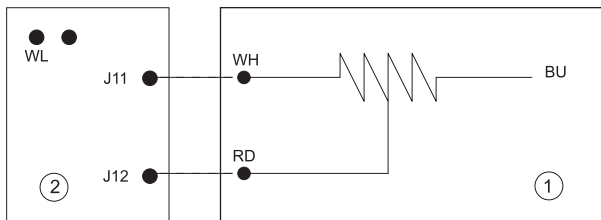

Figure 21 - Remote potentiometer wiring



- 1 = Remote potentiometer
- 2 = ECA Board
- WH = White wire
- RD = Red Wire
- BU = Blue wire
- Factory wiring
- - - - Field wiring

Fire Thermostat

There are two sensors in the fire thermostat Kit: Sensor X13100040-01 is factory-set to open at 57°C, Sensor X13100040-02 is set to open at 115°C.

Sensors are mounted directly in the ductwork. They should be installed where elements can respond quickly to air temperature changes. If not possible, the sensor may be installed on a suitable bracket so the air is drawn across the element. Sensor X13100040-01 has to be mounted in the return air duct. Sensor X13100040-02 has to be mounted in the supply air duct.

Note: Do not permit element guard to touch internal parts. Do not locate sensor where the air circulation is restricted by baffles.

At the selected location, cut a hole to clear element guard and drill holes for mounting screws according to Figure 22. Connect wires according to Figure 23.

Figure 22 - Duct mounting of fire thermostat

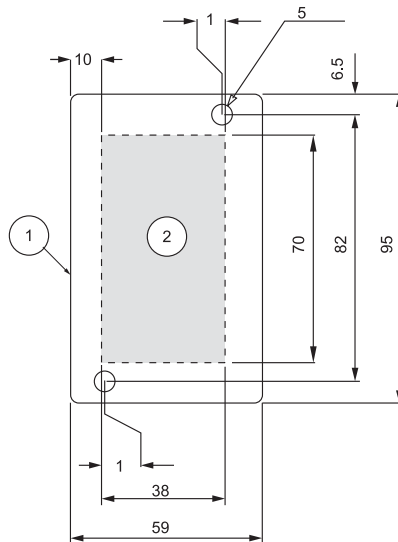

- 1 = Fire thermostat
- 2 = Hole in the duct

Figure 23 - Connection of fire thermostat with TCI board

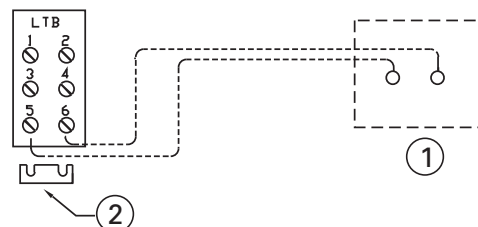

- 1 = Field-supplied emergency stop device
- 2 = Remove factory-supplied jumper

Clogged Filter Detector

This device is mounted in the indoor fan section. The sensor measures the difference in pressure before and after the filter section. The information is sent to the THP03 thermostat, to a Tracker™ or to a BMS. The setting range is 40 to 300 Pa.

Figure 24- Clogged filter sensor

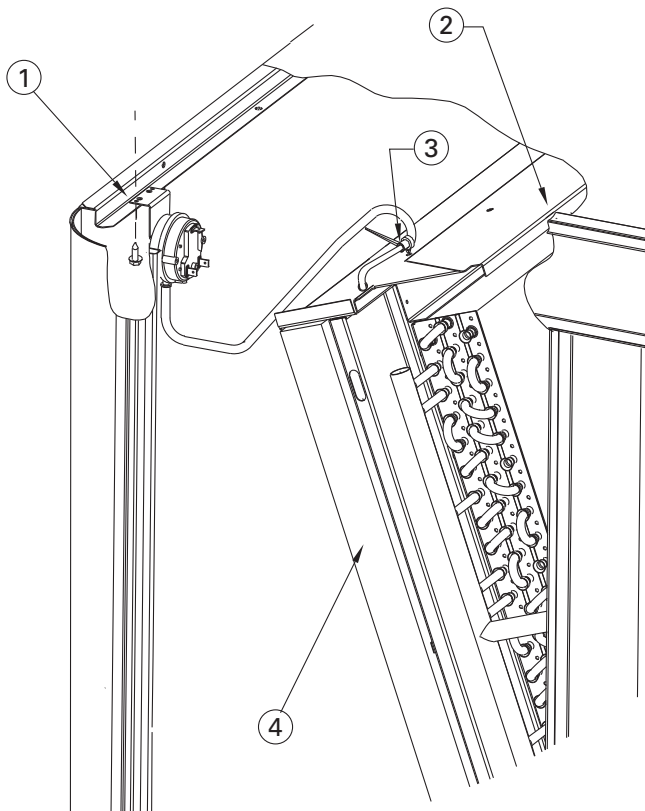

- 1 = Secure with one screw
- 2 = Route wire harness between coil blockoff and roof rib
- 3 = Secure with pop-in wire tie
- 4 = Remove filter if necessary

Smoke Detector

This device is used to detect smoke in the air stream. It includes a factory mounted detector connected to a central panel, both fitted in the fan section.

When smoke is detected, it shuts off the unit. A dry contact is available on the control panel for a remote default.

High Temperature Safety Thermostat

This additional safety device is a manual reset thermostat for gas fired units (YKD/YKH), required mainly by the French ERP regulation. It is located in the gas burner section. It stops the gas burner and the supply air fan when the supply air temperature rises to 120°C.

Remote Fault Relay

This is a factory mounted relay used to send alarm signals (dry contact) to a local BMS or a local control panel. With this relay, the compressor, heating, fan and power supply alarm output signals from the controller are reported to a single dry contact.

Controls

Control Wiring

The control circuit is 24V AC. Unit includes a 400/24V transformer.

WARNING! The unit disconnect switch must be opened and locked open. Risk of injury and electrocution.

CAUTION! The unit 24V transformer must not be used to power accessories mounted on site, other than those proposed by Trane.

Unit controlled by thermostat

Thermostats

2 thermostats are available:

THS03/THP03.

“THS” are non programmable thermostats,
“THP” are programmable.

Figure 25 - Thermostat wiring

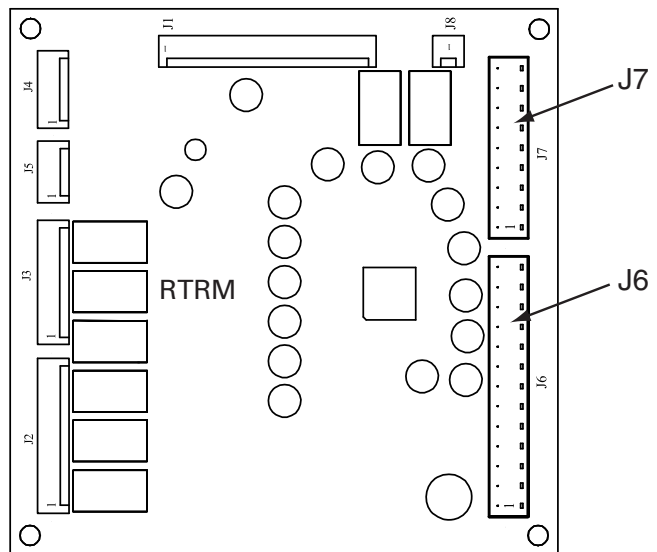

Table 39 - Thermostat features

	Conventional Thermostat	THS03	THP03
Programmable	-/•	-	•
Electronic	•	-	•
Control type design	Electromechanical	Reliatel	
For cooling-only units (TS*/TK*)	•	•	•
For heat pump units (WS*/WK*)	•	•	•
For gas-fired units (YS*/YK*)	•	•	•
Number of cooling stages	2	3	3
Auxiliary heating stages (electric heater, hot water coil)	2	2/1 Modulating	
Liquid crystal display	•	-	•

Note: thermostats are powered up by the rooftop control (24V)

Trane conventional thermostats are directly connected to RTRM board (J7 connector).

Trane THS03 and THP03 zone sensor modules are directly connected to RTRM board (J6 connector).

Install the electrical link between the thermostat (thermostat terminal strip) and the unit (J6 or J7 connector) in compliance with the interconnection diagram. The low voltage wiring must not be laid in the same pipes as the power cables.

The sizes and lengths of the thermostat connection wires are given in Table 39. The total resistance of these control cables must not exceed 5 ohms. If the resistance exceeds this value the thermostat may not operate with the same precision.

Table 40 - Zone sensor wire and maximum length

Wire size (mm ²)	Maximum wire length (m)
0.33	45
0.5	76
0.75	115
1.3	185
2	300

Other accessories available

TZS01: Remote room temperature sensor to be used with THS/THP 03, Tracker or Varitrac systems.

DTS: Duct temperature sensor to be used with THS/THP 03.

TZS02: Remote room temperature sensor with adjustable thumbwheel setpoint to be used with Tracker or Varitrac systems.

TZS04: Room temperature sensor with adjustable thumbwheel and override button, to be used with Tracker or Varitrac systems.

Refer to separate documentation for more information.

Communication Interfaces

TRANE Communication Interface (TCI-R) board

This is an electronic board, factory mounted in the main control panel.

Each unit must be equipped with a TCI-R board. A communication bus (twisted shielded pair) must link each TCI-R to the Trane Roof Top Manager (RTM) or to the communication gateway (in the case of an external BAS). Connect one temperature sensor to each unit.

Unit controlled by Tracker™ supervisor: The units must also be equipped with the TCI-R communication board. One remote sensor is required on each unit for a constant flow volume. In case of a variable flow installation (VariTrac™) these sensors must not be installed. A twisted shielded pair must be used for the communication link. The main functions of the Tracker™ supervisor are control of setpoints, timetable management (Programming) and display of faults. For more details refer to the supervisor documentation.

Modbus Communication Interface (PIC) board

The PIC board is a Modbus protocol communication interface that needs a TCI-R installed to operate. Follow the installation procedures as indicated in the BAS-SVX08 document.

LON Communication Interface (LCI-R) board

This is an electronic board, factory mounted in the main control panel. It is needed to allow communication on a LonTalk® network at the unit level.

LonTalk® Communication Interface (LTCI-R) board allows Voyager units to communicate on a LonTalk® network at the unit level through ICS communication between a ReliaTel™ unit and LonTalk® communication applications. Network variables are based on the LonMark® Space Comfort Controller Functional Profile Template. The LCIV uses a Free Topology transceiver FTT-10A. The FTT-10A transceiver supports non-polarity sensitive, free topology wiring, allowing the system installer to use star, bus, and loop architecture. The LCI-V can also be connected to an optional High Temperature Limit Switch if installed with the rooftop unit. For more information, see attached manual LTCI-IN-1.

Unit Options

Hot Water Coil

In order to prevent water to freeze up in the coil during unoccupied period or shutdown limited period, a thermostat opens when there is a risk of freeze-up. The services of a water treatment specialist are recommended if water used can cause scaling deposits or erosion. Insulate all the water piping likely to be exposed to freezing temperatures in order to avoid freeze up of the coil and heat losses. The water distribution network must be fitted with vents in places where air is likely to be trapped.

The hot water coil is factory mounted in the discharge section. Two holes are provided to connect the hot water coil. They are located at the base of the unit. Remove the central panel to access the coil, using an 8mm wrench (the bolts are located on the bottom part of the panels). The tubes for entering and leaving water are equipped with a threaded female connector.

Water connection inlet/outlet: 1 1/4" ISO R7.

Installation and connection

In order to prevent water to freeze up in the coil during unoccupied period or shutdown limited period, it is recommended to use ethylene glycol. The services of a water treatment specialist are recommended if water used can cause scaling deposits or erosion. Insulate all the water piping likely to be exposed to freezing temperatures in order to avoid freeze up of the coil and heat losses. The water distribution network must be fitted with vents in places where air is likely to be trapped.

Table 41 - Ethylene glycol percentage

Ethylene glycol percentage	Freezing point
(%)	(°C)
10	-4
20	-10

Electric Heater

Electric heaters are fitted on the fan discharge.

Heaters have two heating stages and provided with two types of overheat thermostats:

- Automatic reset thermostats which stop the electric heater when the air temperature rises to 76°C. Automatic reset at 60°C. No alarm output available.
- The manual reset thermostat which stop the unit when the air temperature rises to 120°C. No alarm output available.

Soft Starter

The soft starter is used to achieve a progressive supply fan start and a reduced starting current as well as the motor starting torque. This option is well adapted for textile duct applications. It is factory installed in the main control panel.

The soft starter gradually increases the voltage of the supply fan motor until it reaches full line voltage.

The starting time can be adjusted from 0 to 40 seconds but the soft starter is factory set to the maximum starting time value, 40 seconds.

Figure 27 - Soft starter

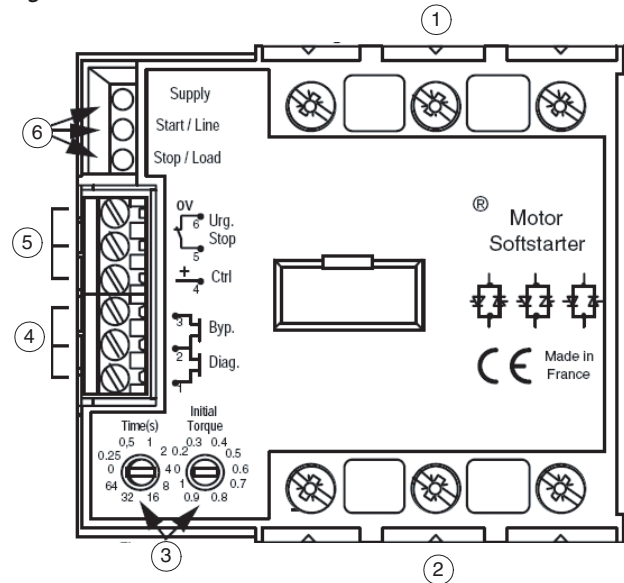

- 1 = Three phase mains connections
- 2 = Motor connections
- 3 = Settings
- 4 = Status outputs
- 5 = Controls
- 6 = LEDs

Figure 26 - Hot water coil connections

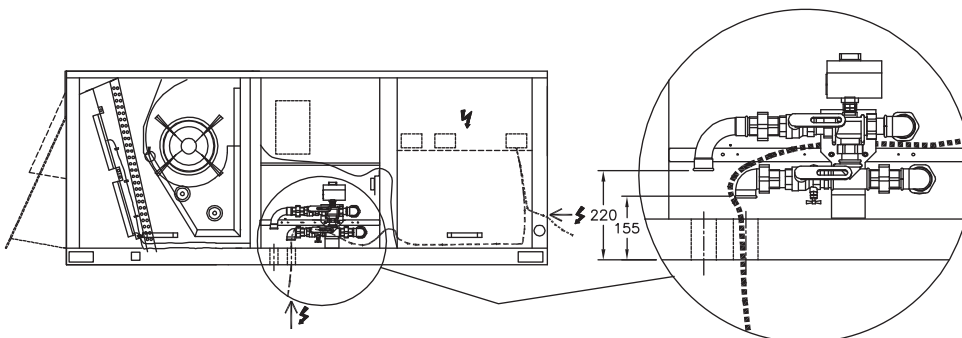

Unit Options

0-50% Fresh Air Hood

The 0-50% fresh air hood allows to introduce fresh air into the unit.

This is a manual device fitted on the back of the unit, sized for a maximum of 50% of the nominal rooftop air flow.

This option includes for the hood itself, a wire mesh and a slidable damper.

The slidable damper has to be adjusted manually by removing the screws and sliding it off up or down (Figure 28).

The amount of fresh air introduced is then permanently fixed.

Figure 28 - 0-50% manual fresh air hood

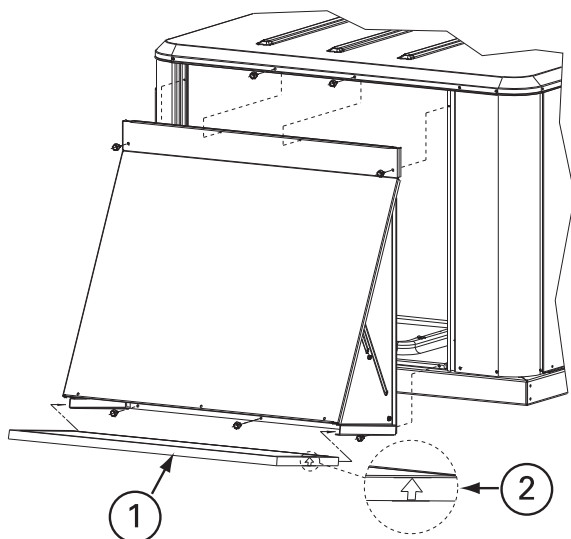

- 1 = Mist eliminator
- 2 = Air flow indicator

Barometric Relief

The barometric relief allows to minimize overpressure in the building caused by the introduction of fresh air. This option is typically installed when fresh air intake is below 25% of the nominal air flow and when the return air pressure drop is below 25Pa.

This option includes an external hood, an internal hood, a gravity damper, and a metallic filter located in the return air section. When the pressure of the building increase, the gravity damper opens and relieves air to the outside.

If the return air duct pressure drop is higher than the building overpressure, the gravity damper will not open.

If the return air duct pressure drop is lower than the building overpressure, the gravity damper will open and relieve air outside of the building.

Figure 29 - Economizer flow chart with barometric relief

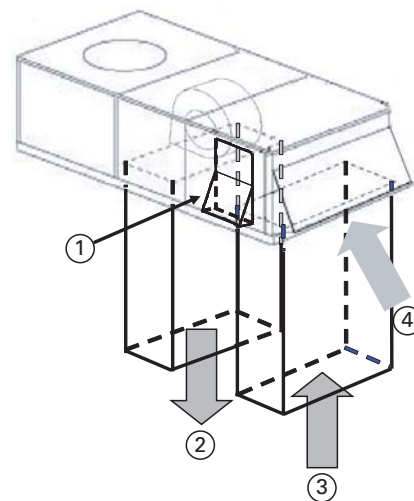

Downflow version

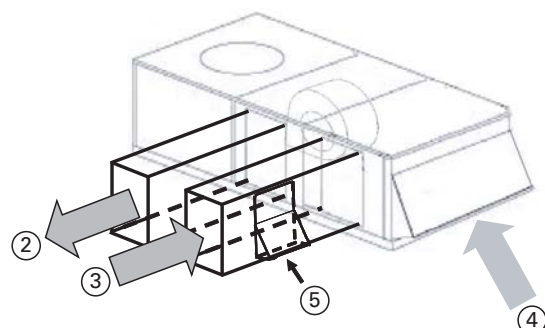

Horizontal flow version

- 1 = Barometric relief installed on the panel that closes the horizontal return air section
- 2 = Supply air
- 3 = Return air
- 4 = Fresh air
- 5 = Barometric relief installed on the return duct

Operation

Operation with a Conventional Thermostat

The ReliaTel module has conventional thermostat connections as well as Zone Sensor Module connections. When a conventional thermostat is controlling the unit, operation differs as follows:

- Supply Air Tempering feature is not available. If outdoor air is being introduced through the equipment, discharge air temperature may be cold when not actively heating.
- Proportional Integral (PI) control is not available.
- Zone Sensor Diagnostics are only available on the RTRM module on the J6 terminals, instead of at the Zone Sensor in the space.
- Intelligent Fall-Back is not available. If a failure occurs in the device controlling the equipment, operation will cease.
- Heat Pump Smart Recovery and Smart Staging is not available. Heat Pump operation becomes more costly unless the generic control being applied can accomplish this.
- Remote Sensing Capabilities are not available on most mechanical thermostats.
- Space Temperature Averaging capabilities are not available on most mechanical thermostats.
- 27½ to 50 VAV - Conventional thermostat input terminals are inactive.
- Built in Night Set Back and Unoccupied Functions function differently with a conventional mechanical thermostat.
- A built-in algorithm which allows for automatic reset of the discharge air temperature while economizing is not available.

The terminal strip for attaching the thermostat wires is located on the RTRM module in the control compartment.

When the unit is operating from a conventional thermostat or other binary input, the economizer setpoint feature, relative to the cooling and heating setpoints, is lost. The economizer control is based strictly on a signal from the thermostat, but still maintains mixed air temperature control of 53°±3°F when in the economizer mode. The economizer enable and disable function is still determined by the outside air sensor through the RTRM.

If a single-stage thermostat is used, only the economizer (if enabled) or the compressor (if economizer is disabled) will operate on a call for cooling. A twostage thermostat is required to achieve economizer operation and compressor operation at the same time.

With economizer enabled, a Y1 call for 1st stage cooling will be the economizer. The damper will modulate between minimum position and 100% to maintain mixed air temperature at 53°±3°. At 50°F the damper will be at minimum position. If the economizer is enabled, a Y2 call for 2nd stage cooling will start the first compressor if required. If the economizer is disabled, 1st stage (Y1) will be the first compressor. If the unit has two compressors, a call for 2nd stage cooling (Y2) will start the second compressor. When using a conventional thermostat, or other binary input, the ReliaTel controls will only allow two stages of cooling.

Figure 30 - Terminal strip

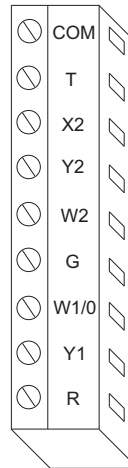

Customers occasionally require operation with a conventional thermostat rather than a zone sensor. In some cases there is a preference for a specific thermostat model, and in others there is reluctance to adopt newer technology that may not be as well understood as conventional thermostats. In addition, non-Trane Building Controllers typically provide an interface to HVAC equipment based on a conventional thermostat interface. Units applied with this type of controller need to accept conventional thermostat inputs.

Conventional thermostat signals represent direct calls for unit functions. In their simplest applications, thermostat contacts directly control contactors or other load switching devices. This function provides inputs for the thermostat signals and processing to enhance reliability and performance. Compressor protection and reliability enhancement functions (HPC, LPC, Minimum On/Off timers, etc.). All operate the same whether applied with zone sensors or a conventional thermostat.

Logic is also provided to cause appropriate unit functions when inappropriate thermostat signals are provided. Simultaneous calls for heating and cooling will be ignored, and the fan will be turned on with a call for heating or cooling even if the fan request is not detected.

If the thermostat is immediately changed from a heating to a cooling call, or vice versa, there will be a five minute delay before the new call will initiate.

Thermostat signals are as follows:

- R 24VAC power to thermostat
- Y1 Call for compressor 1 or first stage cooling
- Y2 Call for compressor 2 or 2nd stage cooling
- G Call for supply fan
- W1 Call for heat 1
- W2 Call for heat 2

Heat pump only:

- X2 Call for emergency heat
- O Switchover valve On = cooling, Off = heating
- T Bias for heat anticipation for those mechanical thermostats that use this function

Table 42

Conventional thermostat Gas/Electric, Electric Heat	
Input/connection	Function when energized
G (fan)	Fan runs continuously except during unoccupied mode (see next page)
Y1 (compressor 1 or economizer)	Compressor #1 runs or economizer operates
Y2 (compressor 2 or compressor 1 while economizing)	Compressor #2 also runs, or #1 compressor runs while economizing
W1 (gas/electric heat first stage)	1st stage heat
W2 (gas/electric heat 2nd stage)	2nd stage heat (if available)

Table 43

Conventional thermostat Heat pump	
Input/connection	Function when energized
Cooling mode	
G (fan)	Fan runs continuously except during unoccupied mode (see next page)
O (reversing valve during cooling)	Reversing valve in cool mode
Y1 + O (first cooling stage)	Compressor #1 runs or economizer operates
Y1 + Y2 + O (2nd cooling stage)	Compressor #2 also runs, or #1 compressor runs while economizing
Heating mode	
G (fan)	Fan runs continuously except during unoccupied mode (see next page)
Y1 (both compressors 1st heating stage)	Both compressors run
Y2 (during heating nothing happens)	No change
W2 (electric heat 2nd stage)	2nd stage (electric) heat
X2 (electric heat only)	Electric heat only - no compressors

T (provides heat anticipation signal for those mechanical thermostats that use this feature. If the thermostat used does not have a "T" terminal, disregard this terminal).



Operation

Unoccupied mode

If the thermostat being used is programmable, it will have its own strategy for unoccupied mode and will control the unit directly. If a mechanical thermostat is being used, a field applied time clock with relay contacts connected to J6-11 and J6-12 can initiate an unoccupied mode as follows:

- Contacts open: Normal occupied operation.
- Contacts closed: Unoccupied operation as follows - Fan in auto mode regardless of fan switch position. Economizer closes except while economizing regardless of minimum position setting.

Cooling/Economizer Operation

If unit does not have an economizer, the Cool/Econ Stage 1 and Stage 2 will call directly for mechanical cooling (compressor) stages. If the unit has an economizer, the Cool/Econ stages will function as shown in Table 46.

Setting the Economizer or 0-50% Motorized Hood (Option)

The ECA board is mounted on the damper actuator.

To access the ECA board on economizers:

- Remove the filter access panel of the unit.
- The electrical power must be disconnected to set the minimum position and check the economizer.
- Disconnect the power supply, put the thermostat fan selector to "ON" and the "HEAT/COOL" selector to "OFF". This puts the damper in the minimum ventilation position.
- To set the required minimum ventilation air position, turn the dial on the ECA clockwise to increase ventilation, or anti-clockwise to decrease ventilation. The damper will open at this setting whenever the fan circuit is powered up (see Figure 25).
- When the arrow on the dial's adjustment screw is pointing to 8 o'clock, the minimum position is roughly 0%. When the dial is pointing to 12 o'clock it is roughly 25%, and when the dial is pointing to 4 o'clock it is roughly 50% (see figure 25).

Table 44 - Cooling/Economizer Operation with Thermostat

OK to Economize?	Thermostat Y1	Thermostat Y2	Call for Economizer Cooling	Compressor Staging Request
No	On	Off	Inactive	Compressor Output 1
No	Off	On	Inactive	Compressor Output 2
No	On	On	Inactive	Compressor Outputs 1 & 2
Yes	On	Off	Active	Off
Yes	Off	On	Active	Compressor off
Yes	On	On	Active	Compressor

Notes:

40 to 50 ton CV only

This unit has 3 stages of cooling if using a zone sensor. If using a conventional thermostat it has 2 stages as follows:

Y1 = 1st stage

Y1 + Y2 = 3rd stage

VAV

Thermostat inputs are ignored on VAV units.

To check the damper is functioning correctly, the ECA is equipped with an indicator light in the middle of the board. This light operates as in Table 42.

Table 45 - ECA board LED

OFF:	No Power or Failure
ON:	Normal, OK to Economize
Slow Flash:	Normal, Not OK to Economize
Fast Flash:	Communications Failure
Pulse Flash:	Error Code
1 Flash:	Actuator Fault
2 Flashes:	CO ₂ Sensor
3 Flashes:	RA Humidity Sensor
4 Flashes:	RA Temp Sensor
5 Flashes:	OA Quality Sensor
6 Flashes:	OA Humidity Sensor
7 Flashes:	OA Temp Sensor
8 Flashes:	MA Temp Sensor
9 Flashes:	RAM Fault
10 Flashes:	ROM Fault
11 Flashes:	EEPROM Fault

While setting the minimum position the damper may move towards the new setting in several small steps. Once the damper has remained in the same position for 10 to 15 seconds it can be assumed it is in the new position.

Figure 31 - Minimum fresh air adjustment

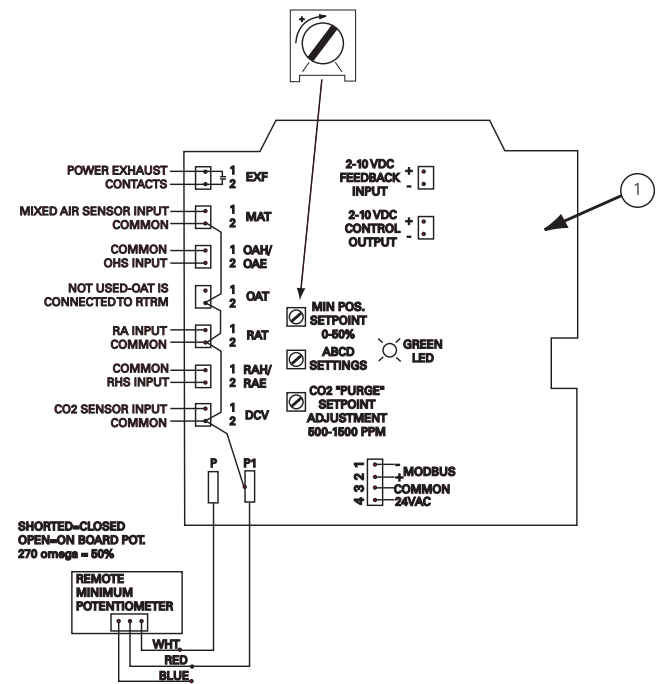



Operation

Test Procedures

Operating checklist before start-up

- Unit is level, with sufficient clearance all round
- Duct network is correctly sized according to the unit configuration, insulated, and water-tight
- Condensate drainage line is correctly sized, equipped with a trap, and sloped
- Filters are in position, of correct size and quantity and clean
- Wiring is correctly sized and connected in accordance with wiring diagrams
- Power supply lines are protected by recommended fuses and correctly earthed
- Thermostat is correctly wired and positioned
- Unit is checked for refrigerant charge and leaks
- Indoor and outdoor fans rotate freely and are fixed on shafts
- Supply fan rotation speed is set
- Access panels and doors are replaced to prevent air entering and risks of injury
- Checking of the gas heating section, in accordance with above procedure

WARNING! If any operating checks must be performed with the unit operating, it is the technician's responsibility to recognize any possible hazards and proceed in a safe manner. Failure to do so could result in severe personal injury or death due to electrical shock or contact with moving parts.

Power-up initialization

CAUTION! Before proceeding with any test procedure or operation, make sure that crankcase heaters have been energized for at least 8 hours.

Units equipped with Scroll compressors do not have crankcase heaters.

Note: Upon power initialization, the RTRM performs self-diagnostic checks to insure that all internal controls are functional. It also checks the configuration parameters against the components connected to the system. The Liteport LED located on the RTRM module is turned "On" within 1 second of power-up if internal operation is okay.

Test mode procedure at the ReliaTel™ control board

Operating the unit from the roof using the test mode at the ReliaTel™ control board.

CAUTION! Before proceeding with the following test procedures, make sure that thermostat or zone sensor is off.

CAUTION! Use one of the following "Test" procedures to bypass some time delays and to start the unit at the control panel.

Each step of unit operation can be activated individually by temporarily shorting across the "Test" terminals for two to three seconds. The Liteport LED located on the RTRM module will blink when the test mode has been initiated. The unit can be left in any "Test" step for up to one hour before it will automatically terminate, or it can be terminated by opening the main power disconnect switch. Once the test mode has been terminated, the Liteport LED will glow continuously and the unit will revert to the "System" control.

Test Modes

There are 2 methods in which the “Test” mode can be cycled with the test button:

1. Step Test Mode

This method initiates the different components of the unit, one at a time, by temporarily shorting across the two test terminals for two to three seconds. For the initial startup of the unit, this method allows the technician to cycle a component “On” and have up to 1 hour to complete the check.

2. Auto Test Mode

This method is not recommended for start-up due to the short timing between individual component steps. This method initiates the different components of the unit, one at a time, when a jumper is installed across the test terminals. The unit will start the first test step and change to the next step every 30 seconds. At the end of the test mode, control of the unit will automatically revert to the applied “System” control method.

For unit test steps and test modes, values to cycle the various components, refer to Tables 48 and 49.

Table 46 - Service Test Guide for Component Operation on cooling only units

Step	Mode	Indoor Fan motor	Economizer	Compressor 1	Compressor 2	Heat 1	Heat 2	Outdoor Fan Motor 1	Outdoor Fan Motor 1
1	Fan On	On	Min	Off	Off	Off	Off	Off	Off
2*	Economizer	On	Open	Off	Off	Off	Off	Off	Off
3	Cool 1	On	Min	On	Off	Off	Off	On	**
4	Cool 2	On	Min	On	On	Off	Off	On	**
5*	Heat 1	On	Min	Off	Off	On	Off	Off	Off
6*	Heat 2	On	Min	Off	Off	On	On	Off	Off

* With Optional Accessory

** “Off” If temperature falls below 16° (±1°C), “On” if temperature rises above 18° (±1°C).

Note: Steps for optional accessories and modes not present in unit will be skipped.

Table 47 - Service Test Guide for Component Operation on Heat Pump Units

Step	Mode	Indoor Fan motor	Economizer	Compressor 1	Compressor 2	Heat 1	Heat 2	Outdoor Fan Motor 1	Outdoor Fan Motor 1
1	Fan On	On	Min	Off	Off	Off	Off	Off	Off
2*	Economizer	On	Open	Off	Off	Off	Off	Off	Off
3	Cool 1	On	Min	On	Off	Off	Off	On	**
4	Cool 2	On	Min	On	On	Off	Off	On	**
5*	Heat 1	On	Min	Off	Off	On	Off	Off	Off
6*	Heat 2	On	Min	Off	Off	On	On	Off	Off

* With Optional Accessory

** “Off” If temperature falls below 16° (±1°C), “On” if temperature rises above 18° (±1°C).

Note: Steps for optional accessories and modes not present in unit will be skipped.

Operation

Unit Start-up

Verification of gas valve settings - (Reserved for the qualified gas technician)

WARNING! Improper gas valve setting may lead to burner destruction and people injury.

Note: Unit factory-set for G20.

Note: Unit to be installed outside only.

Note: Expansion valve must be adapted to the type of gas used:

- G 20: 20mb
- G 25: 25mb
- G 31 (Propane): 37 or 50mb

Figure 32 - Gas valve



Table 48 - Gas type designation per country

Destination countries	Category	Gas type		
		G20	G25	G31
FR	I12E+3P	20	25	37
CH - CZ - ES - GB - GR - IE - PT	I12H3P	20	-	37
IT	I12H3+	20	-	28-30/37
NL	I12L3P	-	25	30
BE	I2E+	20	25	-
DE - LU - PL	I2E	20	-	-
AT - DK - EE - FI - LT - LV - NO - SE - SI - SK - TR	I2H	20	-	-
HU	I2H	-	25	-
BE - CZ - PL - SI - SK - TR	I3P	-	-	37
AT - DE - HU - LU - SK	I3P	-	-	50

Table 49 - Gas burner data

BURNER		G120			G200			G250		
Gas Type		G20	G25	G31	G20	G25	G31	G20	G25	G31
Heating Input (kW)	(kW)	26.5	26.9	27.0	44.4	44.8	45.1	55.8	56.2	56.6
Heating Output (kW)	(kW)	24.6	25	25.1	41.3	41.7	41.9	51.9	52.3	52.6
Efficiency		93%	93%	93%	93%	93%	93%	93%	93%	93%
Gas Flow rate (Nm ³ /h for G20 & G25 - kg/h for G31)		2.8	3.3	2.1	4.7	5.5	3.5	5.9	6.9	4.4
Heating Output per stage (1st/2nd) (%)		0%-100%			0%-100%			0%-70%-100%		0%-70%-100%
Inlet pressure Min/Nominal/Max	(mbar)	17/20/25	20/25/30	25/37/45	17/20/25	20/25/30	25/37/45	17/20/25	20/25/30	25/37/45
Low pressure switch setting	(mbar)	15	15	20	15	15	20	15	15	20
Manifold pressure	(mbar)	7.5	10.5	24.9	7.5	10.5	24.9	7.5	10.5	24.9
No of injectors			3			4			5	
Injector size (Drill/mm)	(Drill/mm)	(33)/2.87			(51)/1.70			(1/8")/3.175		(49)/1.85
SMOKE ANALYSIS										
Gas/Voltage		G20 - 20mbar 400/3/50	G25 - 25mbar 400/3/50	G31 - 37mbar 400/3/50	G20 - 20mbar 400/3/50	G25 - 25mbar 400/3/50	G31 - 37mbar 400/3/50	G20 - 20mbar 400/3/50	G25 - 25mbar 400/3/50	G31 - 37mbar 400/3/50
CO	(%)	0.0012%	0.0017%	0.0003%	0.0020%	0.0015%	0.0011%	0.0020%	0.0015%	0.0011%
Nox	(ppm)	59 ppm	44 ppm	8.7 ppm	10 ppm	10 ppm	11 ppm	10 ppm	10 ppm	11 ppm
CO ₂	(%)	8.29%	9.20%	8.90%	7.10%	7.10%	8.28%	7.10%	7.10%	8.28%

Notes:

(1) G20 heating output given for 34,02 MJ/m³ (15°C-1013)
 (2) G25 heating output given for 29,30 MJ/m³ (15°C-1013)

(3) G31 heating output given for 46.34 MJ/kg
 (4) 1 percent = 10 000 ppm

Operation

Starting the unit in cooling mode

Before start-up, ensure that all power cables are tightened.

Verify that the unit airflow rate is adjusted according to the information provided in the "Supply fan adjustment" section of this manual.

To start the unit in cooling mode:

- Place the zone sensor system switch in the "COOL" position.
- Position the cooling setpoint approximately 10° below room temperature and place the fan switch in the "AUTO" or "ON" position.
- Turn on unit main power supply.

The condenser fan motor, compressor and supply fan motor should operate automatically.

There will be a delay of up to 5 minutes before the unit starts in cooling mode.

Operating pressures

After the unit has operated in cooling mode for a short period of time, install pressure gauges on the gauge ports of the discharge and suction line valves.

Note: To bypass time delays and verify the operation of this unit from the roof, use the "Test procedure" section in this manual. Check the suction and discharge pressures.

Note: Always route refrigerant hoses through the port hole provided and ensure that the compressor access panel is in place.

Cooling shutdown

To exit the test mode, disconnect unit power for 3-5 seconds and reapply. When running the unit using the zone sensor as the control, position the selector switch to "OFF".

There may be a delay of up to 3 minutes before compressors shut down and an additional one minute before the fan shuts down in this setting.

Do not de-energize main power disconnect except when unit is to be serviced. Power is required to keep the compressor crankcase warm and boil off refrigerant in the oil (except on units with Scroll compressors).

Final installation checklist

- Are all power cables tightened?
Check torque of power cables contact!
- Is the condenser fan and indoor blower operating correctly, i.e. correct rotation and without undue noise?
- Are the compressors operating correctly and has the system been checked for leaks?
- Have the voltage and running currents been checked to determine if they are within limits?
- Have the air discharge grilles been adjusted to balance the system?
- Has the ductwork been checked for air leaks and any condensation?

- Has the air temperature rise been checked?
- Has the indoor airflow been checked and adjusted if necessary?
- Has the unit been checked for tubing and sheet metal rattles or any unusual noises?
- Are all covers and panels in place and properly fastened?

ReliaTel™ is a microelectronic control feature, which provides operating functions that are significantly different from conventional electro-mechanical units. The master module is the ReliaTel™ Refrigeration Module (RTRM).

The RTRM provides compressor antishort cycle timing functions through minimum "Off" and "On" timing to increase reliability, performance and to maximize unit efficiency.

Upon power initialization, the RTRM performs self-diagnostic checks to insure that all internal controls are functioning. It checks the configuration parameters against the components connected to the system.

The LED located on the RTRM module is turned "On" within one second after power-up if all internal operations are okay.

Cooling without an Economizer

When the system switch is set to the "Cool" position and the zone temperature rises above the cooling setpoint controlband, the RTRM energizes the (K9) relay coil located on the RTRM. When the K9 relay contacts close, the compressor contactor (CC1) coil is energized provided the low pressure control (LPC1) and high pressure control (HPC1) are closed. When the CC1 contacts close, compressor (CPR1) and the outdoor fan motor (ODM) start to maintain the zone temperature to within ± 2 F of the sensor setpoint at the sensed location.

If the first stage of cooling can not satisfy the cooling requirement, the RTRM energizes the (K10) relay coil located on the RTRM. When the (K10) relay contacts close, the compressor contactor (CC2) coil is energized provided the low pressure control (LPC2) and high pressure control (HPC2) are closed. When the CC2 contacts close, compressor (CPR2) starts to maintain the zone temperature to within ± 2 F of the sensor setpoint at the sensed location.

Evaporator Fan Operation

When the fan selection switch is set to the "Auto" position, the RTRM energizes the (K6) relay coil approximately one second after energizing the compressor contactor coil (CC1) in the cooling mode. In heating mode, the RTRM energizes the (K6) relay coil approximately 45 seconds after gas ignition. Closing the K6 contacts on the RTRM energizes the supply fan relay (F) coil to start the supply fan motor (IDM).



Operation

The RTRM de-energizes the fan relay (F) approximately 60 seconds after the cooling requirement has been satisfied to enhance unit efficiency.

When the heating cycle is terminated, the supply fan relay (F) coil is de-energized approximately 90 seconds after the heating requirement.

When the fan selection switch is set to the "On" position, the RTRM keeps the supply fan relay coil (F) energized for continuous fan motor operation.

When the unit is equipped with the optional clogged filter switch, wired between terminals J7-3 and J7-4 on the ReliaTel™ Options Module (RTOM), the RTRM produces an analog output if the clogged filter switch (CFS) closes for two minutes after a request for fan operation. When the system is connected to a remote panel, the "SERVICE" LED will be turned on when this failure occurs.

Low Ambient Operation

During low ambient operation, outside air temperature below 13°C, the RTRM will cycle the compressor and outdoor fan motor "Off" for approximately three minutes after every 10 minutes of accumulated compressor run time. The supply fan motor (IDM) will continue to operate during this evaporator defrost cycle (EDC) and the compressor and outdoor fan will return to normal operation once the defrost cycle has terminated and the compressor "Off" time delay has been satisfied.

Cooling with an Economizer

The economizer is utilized to control the zone temperature providing the outside air conditions are suitable.

Outside air is drawn into the unit through modulating dampers. When cooling is required and economizing is possible, the RTRM sends the cooling request to the unit economizer actuator (ECA) to open the economizer damper. The RTRM tries to cool the zone utilizing the economizer to slightly below the zone temperature setpoint. If the mixed air sensor (MAS) senses that the mixed air temperature is below 53°F, the damper modulates toward the closed position. If the zone temperature continues to rise above the zone temperature setpoint controlband and the economizer damper is full open, the RTRM energizes the compressor contactor (CC1). If the zone temperature continues to rise above the zone temperature setpoint controlband and the economizer damper is fully open, the RTRM energizes the compressor contactor (CC2).

The ECA continues to modulate the economizer damper open/closed to keep the mixed air temperature that is calculated by the RTRM.

If economizing is not possible, the ECA drives the damper to the minimum position setpoint when the supply fan relay (F) is energized and allows mechanical cooling operation. When the unit is equipped with the optional fan failure switch, wired between terminals J7-5 and J7-6 on the RTOM, the RTRM will stop all cooling functions and produce an analog output if the fan failure switch (FFS) does not open within 40 seconds after a request for fan operation. When the system is connected to a remote panel, the "SERVICE" LED will flash when this failure occurs.

Economizer Set-up

Adjusting the minimum position potentiometer located on the unit economizer Actuator (ECA) sets the required amount of ventilation air.

Two of the three methods for determining the suitability of the outside air can be selected utilizing the enthalpy potentiometer on the ECA, as described below:

1. Ambient Temperature - controlling the economizing cycle by sensing the outside air dry bulb temperature. The Table below lists the selectable dry bulb values by potentiometer setting.
2. Reference Enthalpy - controlling the economizer cycle by sensing the outdoor air humidity. The Table below lists the selectable enthalpy values by potentiometer setting. If the outside air enthalpy value is less than the selected value, the economizer is allowed to operate.
3. Comparative Enthalpy - By utilizing a humidity sensor and a temperature sensor in both the return air stream and the outdoor air stream, the unit control processor (RTRM) will be able to establish which conditions are best suited for maintaining the zone temperature, i.e. indoor conditions or outdoor conditions. The potentiometer located on the ECA is non-functional when both the temperature and humidity sensors are installed.

Table 50 - Potentiometer Setting

Potentiometer Setting	Dry Bulb (°C)	Enthalpy (KJ/kg)
A	23*	63
B	21	58
C	19	53
D	17	51

*Factory Setting

ReliaTel™ Control Heating Operation

When the system switch is set to the “Heat” position and the zone temperature falls below the heating setpoint controlband, a heat cycle is initiated when the RTRM communicates ignition information to the Ignition module (IGN).

Ignition Module

Two Stage (IGN) runs self-check (including verification that the gas valve is de-energized). (IGN) checks the high-limit switches (TC01 & TC02) for normally closed contacts. With 115 VAC power supplied to the ignition module (IGN), the hot surface ignition probe (IP) is preheated for approximately 45 seconds. The gas valve (GV) is energized for approximately 7 seconds for trial for ignition, to ignite the burner.

Once the burner is ignited, the hot surface ignition probe (IP) is de-energized by the ignition module (IGN) and functions as the flame sensing device.

If the burner fails to ignite, the ignition module will make two more attempts before locking out. The green LED will indicate a lock out by two fast flashes. An ignition lockout can be reset by:

1. Opening for 3 seconds and closing the main power disconnect switch
2. By switching the “Mode” switch on the zone sensor to “OFF” and then to the desired position
3. Allowing the ignition control module to reset automatically after one hour.

Refer to the ignition control module diagnostics section for the LED diagnostic definitions.

When the fan selection switch is set to the “Auto” position, the RTRM energizes the supply fan relay (F) coil approximately 30 second after initiating the heating cycle to start the supply fan motor (IDM).

The automatic reset high limit (TCO1), located in the bottom right corner of the burner compartment, protects against abnormally high leaving air temperatures.

The automatic reset fan fail limit (TCO2), located in the upper middle section of the supply fan board, protects against abnormally high heat buildup which could occur because of extended cycling of the high limit (TCO1) or if the supply fan motor (IDM) fails to operate. Should TCO2 open, the RTRM will energize the supply fan relay (F) in an attempt to start the fan motor. The RTRM signals that a heat failure has occurred by flashing the “Heat” LED on the zone sensor.

There is a Green LED located in the Ignition Control Module. The table below lists the diagnostics and the status of the LED during the various operating states.

Final Installation Checklist

- Is the condenser fan and indoor blower operating correctly, i.e.: correct rotation and without undue noise?
- Are the compressors operating correctly and has the system charge been checked?
- Has the gas module been installed as per the procedure in this manual?
- Have the voltage and running currents been checked to determine if they are with in limits?
- Have the air discharge grilles been adjusted to balance the system?
- Has the ductwork been checked for air leaks and any condensation?
- Has the heating air temperature rise been checked?
- Has the indoor airflow been checked and adjusted if necessary?
- Has the unit been checked for tubing and sheet metal rattles or any unusual noises?
- Are all covers and panels in place and properly fastened?

To keep the unit operating safely and efficiently, the manufacturer recommends that a qualified service technician check the entire system at least once each year, or more frequently if conditions warrant.

Table 51 - LED status

Diagnostics	Green LED	Red LED
1. Powered but no heat demand	Off	Off
2. Heat demand without fault	Flash ing	Off
3. No flame detection on ignition - or signal detected and then lost	Off	Flashing
4. Gas unit incorrectly wired or flame signal detected on a heat demand	Steady	Flashing
5. Internal fault	Off	Steady



Maintenance

To keep the unit operating safely and efficiently, the manufacturer recommends that a qualified service technician check the entire system at least once each year, or more frequently if conditions warrant it.

End-user Routine Maintenance

Some of the periodic maintenance functions for the unit can be undertaken by the end user. This includes replacing (disposable) or cleaning (permanent) air filters, cleaning unit cabinet, cleaning the condenser coil, and carrying out a general unit inspection on a regular basis.

WARNING! Disconnect the power supply before removing access panels to service the unit. Failure to disconnect power before attempting any servicing can result in severe injury or death.

Air filters

It is very important for the central duct system air filters to be kept clean.

These should be inspected at least once a month when the system is in constant operation (in new buildings, the filters should be checked every week for the first four weeks). If disposable-type filters are used, they should only be replaced with ones of the same type and size.

Note: Do not attempt to clean disposable filters.

Permanent filters can be cleaned by washing with a mild detergent and water. Ensure that the filters are thoroughly dry before reinstalling them in the unit (or duct system).

Note: Replace permanent filters annually if washing fails to clean them, or they show signs of deterioration. Be sure to use the same type and size as were originally installed.

Condenser coil

Unfiltered air circulates through the unit's condenser coil and can cause the coil's surface to become clogged with dust, dirt, etc. To clean the coil, brush the coil surface in the direction of the fins with a soft bristled brush.

Keep all vegetation away from the condenser coil area.

Hot water coil (option)

Stop the unit. Do not disconnect the main supply to the unit. This will permit the anti-frost protection to continue to operate, and avoid water to freeze-up in the coil.

Service Technician Maintenance

Before the cooling season, your service technician may examine the following areas of your unit:

- Filters, for cleaning or replacement
- Motors and drives system components
- Economizer gaskets, for replacement if necessary
- Condenser coils, for cleaning
- Safety controls, for mechanical cleaning
- Electrical components and wiring, for replacement and tightening of connections as necessary
- Condensate drain, for cleaning
- Unit duct connections, to ensure they are physically sound and sealed to the unit casing
- Unit mounting support, to ensure that it is sound
- The unit, to ensure there is no obvious deterioration

Before the heating season, your service technician may examine the following areas of your unit:

- The unit, to ensure that the condenser coil can receive the required airflow (that the condenser fan grille is not obstructed)
- The control panel wiring, to verify that all electrical connections are tight, and that wire insulation is intact
- Clean burner area, verify the gas heat system operates properly.

Troubleshooting

The RTRM has the ability to provide the service personnel with some unit diagnostics and system status information. Before turning the main power disconnect switch "Off", follow the steps below to check the ReliaTel™

Refrigeration Module (RTRM). All diagnostics & system status information stored in the RTRM will be lost when the main power is turned "Off".

1. Verify that the Liteport LED on the RTRM is burning continuously. If the LED is lit, go to Step 3.
2. If the LED is not lit, verify that 24 VAC is present between J1-1 and J1-2. If 24 VAC is present, proceed to Step 3. If 24 VAC is not present, check the unit main power supply, check transformer (TNS1). Proceed to Step 3 if necessary.
3. Utilizing "Method 1" or "Method 2" in the system status diagnostic section, check the following: System status, Heating status, Cooling status. If a System failure is indicated, proceed to Step 4. If no failures are indicated, proceed to Step 5.
4. If a System failure is indicated, recheck Steps 1 and 2. If the LED is not lit in Step 1, and 24 VAC is present in Step 2, the RTRM has failed. Replace the RTRM.
5. If no failures are indicated, use one of the TEST mode procedures described in the unit "Start-Up" section to start the unit. This procedure will allow you to check all of the RTRM outputs, and all of the external controls (relays, contactors, etc.) that the RTRM outputs energize, for each respective mode. Proceed to Step 6.

Maintenance

6. Step the system through all of the available modes, and verify operation of all outputs, controls, and modes. If a problem in operation is noted in any mode, you may leave the system in that mode for up to one hour while troubleshooting. Refer to the sequence of operations for each mode, to assist in verifying proper operation. Make the necessary repairs and proceed to Steps 7 and 8.
7. If no abnormal operating conditions appear in the test mode, exit the test mode by turning the power "Off" at the main power disconnect switch.
8. Refer to the individual component test procedures if other microelectronic components are suspect.

System Status Checkout Procedure

"System Status" is checked by using one of the following two methods:

Method 1

If the Zone Sensor Module (ZSM) is equipped with a remote panel with LED status indication, you can check the unit within the space. If the ZSM does not have LED's, use Method 2.

THS/P03 have the remote panel indication feature. The LED descriptions are listed below:

LED 1 (System) "On" during normal operation. "Off" if a system failure occurs or the LED fails. "Flashing" indicates test mode.

LED 2 (Heat) "On" when the heat cycle is operating. "Off" when the heat cycle terminates or the LED fails. "Flashing" indicates a heating failure.

LED 3 (Cool) "On" when the cooling cycle is operating. "Off" when the cooling cycle terminates or the LED fails. "Flashing" indicates a cooling failure.

LED 4 (Service) "On" indicates a clogged filter. "Off" during normal operation. "Flashing" indicates an supply fan failure.

Below is the complete listing of failure indication causes:

System failure

Check the voltage between terminals 6 and 9 on J6, it should read approximately 32 VDC. If no voltage is present, a system failure has occurred. Refer to Step 4 in the previous section for the recommended troubleshooting procedure.

Heating Failure

Verify Heat Failure by Ignition Module (IGN) LED indicator:

OFF: No Power or Failure

ON: Normal

Slow Flash: Normal, Heat Call

Fast Flash: Error Code:

- 1 Flash: Communication Failure
- 2 Flashes: System Lockout

- 3 Flashes: Pressure Switch Fail
- 4 Flashes TC01 or TC02 Open
- 5 Flashes: Flame w/o Gas Valve
- 6 Flashes: Flame Rollout Open

Cooling Failure

1. Cooling and heating set point (slide pot) on the zone sensor has failed. Refer to the "Zone Sensor Test Procedure" section.
2. Zone temperature thermistor ZTEMP on ZTS failed. Refer to the "Zone Sensor Test Procedure" section.
3. CC1 or CC2 24 VAC control circuit has opened, check CC1 & CC2 coils, and any of the controls below that apply to the unit (HPC1, HPC2).
4. LPC1 has opened during the 3 minute minimum "on time" during 4 consecutive compressor starts, check LPC1 or LPC2 by testing voltage between the J1-8 & J3-2 terminals on the RTRM and ground. If 24 VAC is present, the LPC's has not tripped. If no voltage is present, LPC's has tripped.

Service Failure

1. If the supply fan proving switch has closed, the unit will not operate (when connected to RTOM), check the fan motor, belts, and proving switch.
2. Clogged filter switch has closed, check the filters.

Simultaneous Heat and Cool Failure

1. Emergency Stop is activated

Method 2

The second method for determining system status is done by checking voltage readings at the RTRM (J6).

The system indication descriptions and the approximate voltages are listed below.

System Failure

Measure the voltage between terminals J6-9 & J6-6.

Normal Operation = approximately 32 VDC

System Failure = less than 1 VDC, approximately 0.75 VDC

Test Mode = voltage alternates between 32 VDC & 0.75 VDC

Heat Failure

Measure the voltage between terminals J6-7 & J6-6.

Heat Operating = approximately 32 VDC

Heat Off = less than 1 VDC, approximately 0.75 VDC

Heating Failure = voltage alternates between 32 VDC & 0.75 VDC

Cool Failure

Measure the voltage between terminals J6-8 & J6-6.

Cool Operating = approximately 32 VDC



Maintenance

Cool Off = less than 1 VDC, approximately 0.75 VDC

Cooling Failure = voltage alternates between 32 VDC & 0.75 VDC

Service Failure

Measure the voltage between terminals J6-10 & J6-6.

Clogged Filter = Approximately 32 VDC.

Normal = Less than 1 VDC, approximately 0.75 VDC

Fan Failure = voltage alternates between 32 VDC & 0.75 VDC.

To use LED's for quick status information at the unit, purchase a ZSM and connect wires with alligator clamps to terminals 6 through 10.

Connect each respective terminal wire (6 through 10) from the Zone Sensor to the unit J6 terminals 6 through 10.

Note: If the system is equipped with a programmable zone sensor THS03, the LED indicators will not function while the ZSM is connected.

Resetting Cooling and Ignition Lockouts

Cooling Failures and Ignition

Lockouts are reset in an identical manner. Method 1 explains resetting the system from the space, Method 2 explains resetting the system at the unit.

Note: Before resetting Cooling Failures and Ignition Lockouts, check the Failure Status Diagnostics by the methods previously explained.

Diagnostics will be lost when the power to the unit is disconnected.

Method 1

To reset the system from the zone, turn the "Mode" selection switch at the zone sensor to the "Off" position.

After approximately 30 seconds, turn the "Mode" selection switch to the desired mode, i.e. Heat, Cool or Auto.

Method 2

To reset the system at the unit, cycle the unit power by turning the disconnect switch "Off" and then "On".

Lockouts can be cleared through the building management system. Refer to the building management system instructions for more information.

Zone Temperature Sensor (ZTS) Service Indicator

The ZSM SERVICE LED is a generic indicator that will signal the closing of a Normally Open switch at any time, providing the Indoor Motor (IDM) is operating. This indicator is usually used to indicate a clogged filter, or an air side fan failure.

The RTRM will ignore the closing of this Normally Open switch for 2 (\pm 1) minutes. This helps prevent nuisance SERVICE LED indications. The exception is the LED will flash 40 seconds after the fan is turned "On" if the Fan Proving Switch is not made.

Clogged Filter Switch

This LED will remain lit the entire time that the Normally Open switch is closed. The LED will be turned off immediately after resetting the switch (to the Normally Open position), or any time that the IDM is turned "Off".

If the switch remains closed, and the IDM is turned "On", the SERVICE LED will be turned "On" again after the 2 (\pm 1) minute ignore delay.

This LED being turned "On", will have no other affect on unit operation. It is an indicator only.

Fan Failure Switch

When the "Fan Failure" switch is wired to the RTOM, the LED will remain flashing the entire time the fan proving switch is closed, indicating a fan failure, and it will shut the unit operations down.

Table 52 - Refrigerant saturated temperature/pressure

Refrigerant T° sat	R410A P sat relative
-20.0°C	3.0 bar
-19.0°C	3.2 bar
-18.0°C	3.3 bar
-17.0°C	3.5 bar
-16.0°C	3.6 bar
-15.0°C	3.8 bar
-14.0°C	4.0 bar
-13.0°C	4.2 bar
-12.0°C	4.4 bar
-11.0°C	4.6 bar
-10.0°C	4.7 bar
-9.0°C	4.9 bar
-8.0°C	5.2 bar
-7.0°C	5.4 bar
-6.0°C	5.6 bar
-5.0°C	5.8 bar
-4.0°C	6.0 bar
-3.0°C	6.3 bar
-2.0°C	6.5 bar
-1.0°C	6.8 bar
0.0°C	7.0 bar
1.0°C	7.3 bar
2.0°C	7.5 bar
3.0°C	7.8 bar
4.0°C	8.1 bar
5.0°C	8.4 bar
6.0°C	8.7 bar
7.0°C	9.0 bar
8.0°C	9.3 bar
9.0°C	9.6 bar
10.0°C	9.9 bar
11.0°C	10.2 bar
12.0°C	10.5 bar
13.0°C	10.9 bar
14.0°C	11.2 bar
15.0°C	11.6 bar
16.0°C	11.9 bar
17.0°C	12.3 bar
18.0°C	12.7 bar
19.0°C	13.1 bar
20.0°C	13.5 bar
21.0°C	13.9 bar
22.0°C	14.3 bar
23.0°C	14.7 bar
24.0°C	15.1 bar

Refrigerant T° sat	R410A P sat relative
25.0°C	15.6 bar
26.0°C	16.0 bar
27.0°C	16.5 bar
28.0°C	16.9 bar
29.0°C	17.4 bar
30.0°C	17.9 bar
31.0°C	18.4 bar
32.0°C	18.9 bar
33.0°C	19.4 bar
34.0°C	19.9 bar
35.0°C	20.5 bar
36.0°C	21.0 bar
37.0°C	21.5 bar
38.0°C	22.1 bar
39.0°C	22.7 bar
40.0°C	23.3 bar
41.0°C	23.9 bar
42.0°C	24.5 bar
43.0°C	25.1 bar
44.0°C	25.7 bar
45.0°C	26.3 bar
46.0°C	27.0 bar
47.0°C	27.7 bar
48.0°C	28.3 bar
49.0°C	29.0 bar
50.0°C	29.7 bar
51.0°C	30.4 bar
52.0°C	31.1 bar
53.0°C	31.9 bar
54.0°C	32.6 bar
55.0°C	33.4 bar
56.0°C	34.2 bar
57.0°C	35.0 bar
58.0°C	35.8 bar
59.0°C	36.6 bar
60.0°C	37.4 bar
61.0°C	38.3 bar
62.0°C	39.1 bar
63.0°C	40.0 bar
64.0°C	40.9 bar
65.0°C	41.8 bar
66.0°C	42.8 bar
67.0°C	43.7 bar
68.0°C	44.7 bar
69.0°C	45.7 bar
70.0°C	46.7 bar



Maintenance

Zone Temperature Sensor (ZTS) Test

Note: These procedures are not for programmable or digital models and are conducted with the Zone Sensor

Module electrically removed from the system.

Test 1

Zone Temperature Thermistor (ZTEMP)

This component is tested by measuring the resistance between terminals 1 and 2 on the Zone Temperature Sensor.

Table 53 - Thermistor Resistance/Temperature Chart

Temperature/resistance coefficient is negative.

Temperature (°C)	Resistance (kOhms)
-21	103
-15	74.65
-9	54.66
-7	46.94
-4	40.4
-1	34.85
2	30.18
4	26.22
7	22.85
10	19.96
13	17.47
16	15.33
18	13.49
21	11.89
24	10.5
27	9.297
29	8.247
32	7.33
35	6.528
38	5.824

To Test Humidity Sensors

Return Air Humidity Sensor ECA RAH/RAE

Outdoor Humidity Sensor ECA OAH/OAE

To test this circuit, place a DC milliamp meter in series with either of the leads to the humidity sensor. If the reading is 0ma, polarity may be reversed. Reverse + & - and retest. If the reading does not correspond to the table below, check the output voltage from the ECA with the sensor disconnected. It should be approximately 20VDC. If so, and all connections are intact, replace the sensor. If 20VDC is not present, yet the ECA green LED is on, the ECA module has failed. **Humidity sensor accuracy: +/-10% RH.**

Table 54 - Humidity sensor test

RH%	DCma	RH%D	Cma	RH%	DCma
100%	20.000	52.6	12.414	31.2	9.000
97.7	19.636	51.7	12.273	30.8	8.926
95.5	19.286	50.8	12.135	30.3	8.852
93.4	18.947	50.0	12.000	29.9	8.780
91.4	18.621	49.2	11.868	29.4	8.710
89.4	18.305	48.4	11.739	29.0	8.640
87.5	18.000	47.6	11.613	28.6	8.571
85.7	17.705	46.8	11.489	28.1	8.504
83.9	17.419	46.1	11.368	27.7	8.438
82.1	17.143	45.3	11.250	27.3	8.372
80.5	16.875	44.6	11.134	26.9	8.308
78.8	16.615	43.9	11.020	26.5	8.244
77.3	16.364	43.2	10.909	26.1	8.182
75.7	16.119	42.5	10.800	25.8	8.120
74.3	15.882	41.8	10.693	25.4	8.060
72.8	15.652	41.2	10.588	25.0	8.000
71.4	15.429	40.5	10.485	24.6	7.941
70.1	15.211	39.9	10.385	24.3	7.833
68.8	15.000	39.3	10.286	23.9	7.826
67.5	14.795	38.7	10.189	23.6	7.770
66.2	14.595	38.1	10.093	23.2	7.714
65.0	14.400	37.5	10.000	22.9	7.660
63.8	14.211	36.9	9.908	22.5	7.606
62.7	14.026	36.4	9.818	22.2	7.552
61.5	13.846	35.8	9.730	21.9	7.500
60.4	13.671	35.3	9.463	21.6	7.448
59.4	13.500	34.7	9.558	21.2	7.397
58.3	13.333	34.2	9.474	20.9	7.347
57.3	13.171	33.7	9.391	20.6	7.297
56.3	13.012	33.2	9.310	20.3	7.248
55.4	12.857	32.7	9.231	20.0	7.200
54.4	12.706	32.2	9.153		
53.5	12.558	31.7	9.076		



Notes



Notes



Trane optimizes the performance of homes and buildings around the world. A business of Ingersoll Rand, the leader in creating and sustaining safe, comfortable and energy efficient environments, Trane offers a broad portfolio of advanced controls and HVAC systems, comprehensive building services and parts. For more information visit www.Trane.com

© 2014 Trane All rights reserved
RT-SVX20D-E4 July 2014
Supersedes RT-SVX20C-E4_0610

We are committed to using environmentally
conscious print practices that reduce waste.

