



# Installation Operation Maintenance

**UniTrane™ FCD ducted fan coil units**

**Sizes 101-103-203-204-304-306-406-408-508-512-612-721**

**UniTrane™ FED ducted fan coil units**

**Sizes 100-200-300-400-500-600**





# General Information

---

## Foreword

These instructions are given as a guide to good practice in the installation, start-up, operation, and maintenance by the user, of Trane UniTrane™ FCD/FED fan coil units. They do not contain full service procedures necessary for the continued successful operation of this equipment. The services of a qualified technician should be employed through the medium of a maintenance contract with a reputable service company. Read this manual thoroughly before unit start-up.

## Warnings and cautions

Warnings and Cautions appear at appropriate sections throughout this manual. Your personal safety and the proper operation of this machine require that you follow them carefully. The constructor assumes no liability for installations or servicing performed by unqualified personnel.

**WARNING!** : Indicates a potentially hazardous situation which, if not avoided, could result in death or serious injury.

**CAUTION!** : Indicates a potentially hazardous situation which, if not avoided, may result in minor or moderate injury. It may also be used to alert against unsafe practices or for equipment or property-damage-only accidents.

## Safety recommendations

To avoid death, injury, equipment or property damage, the following recommendations should be observed during maintenance and service visits:

1. The maximum allowable pressures for system leak testing on low and high pressure side are given in the chapter "Installation". Always provide a pressure regulator.
2. Disconnect the main power supply before any servicing on the unit.
3. Service work on the refrigeration system and the electrical system should be carried out only by qualified and experienced personnel.

## Reception

On arrival, inspect the unit before signing the delivery note.

### Reception in France only:

In case of visible damage: The consignee (or the site representative) must specify any damage on the delivery note, legibly sign and date the delivery note, and the truck driver must countersign it. The consignee (or the site representative) must notify Trane Epinal Operations - Claims team and send a copy of the delivery note. The customer (or the site representative) should send a registered letter to the last carrier within 3 days of delivery.

Note: for deliveries in France, even concealed damage must be looked for at delivery and immediately treated as visible damage.

### Reception in all countries except France:

In case of concealed damage: The consignee (or the site representative) must send a registered letter to the last carrier within 7 days of delivery, claiming for the described damage. A copy of this letter must be sent to Trane Epinal Operations - Claims team.

### Storage until installation

Units must be stored in a closed environment, protected from weather.

The humidity of the storage environment shall not exceed 70% relative humidity.

## General Information

---

### Warranty

Warranty is based on the general terms and conditions of the manufacturer. The warranty is void if the equipment is repaired or modified without the written approval of the manufacturer, if the operating limits are exceeded or if the control system or the electrical wiring is modified. Damage due to misuse, lack of maintenance or failure to comply with the manufacturer's instructions or recommendations is not covered by the warranty obligation. If the user does not conform to the rules of this manual, it may entail cancellation of warranty and liabilities by the manufacturer.

### Maintenance contract

It is strongly recommended that you sign a maintenance contract with your local Service Agency. This contract provides regular maintenance of your installation by a specialist in our equipment. Regular maintenance ensures that any malfunction is detected and corrected in good time and minimizes the possibility that serious damage will occur. Finally, regular maintenance ensures the maximum operating life of your equipment. We would remind you that failure to respect these installation and maintenance instructions may result in immediate cancellation of the warranty.

### Training

To assist you in obtaining the best use of it and maintaining it in perfect operating condition over a long period of time, the manufacturer has at your disposal a refrigeration and air conditioning service school. The principal aim of this is to give operators and technicians a better knowledge of the equipment they are using, or that is under their charge. Emphasis is particularly given to the importance of periodic checks on the unit operating parameters as well as on preventive maintenance, which reduces the cost of owning the unit by avoiding serious and costly breakdown.



# Contents

---

General information	2
<b>Installation</b>	<b>5</b>
Unit identification	5
General data	7
Operating limits (temperature and airflow)	11
Water quality recommendations	11
Handling the unit	12
Mounting the accessories	12
Mounting the unit in the ceiling	14
Ductwork connection	17
Water connection	19
Condensate drainage connection	23
Electrical connection	28
Connecting the thermostats	32
Main power supply	39
External static pressure and airflow curves	40
Water pressure drop curves	48
Pre-start checkout	53
Installation checklist	53
Commissioning	53
<b>Maintenance</b>	<b>54</b>
Servicing the electric heater	54
Accessing the filter	54
Servicing the coil	56
Servicing the fan motor assembly	57
Periodic maintenance	58
<b>User guide</b>	<b>59</b>
Thermostats Type L, M, N, P, E for FCD	59

# Installation

## Unit identification

Units arrive on site with an identification sticker with pictograms, which clearly indicates important information such as the customer order number, job name,

unit model size, coil type, presence of an electric heater, motor type, unit handing, speed wiring, and so on. (See Figure 1)

Figure 1 - Unit identification sticker

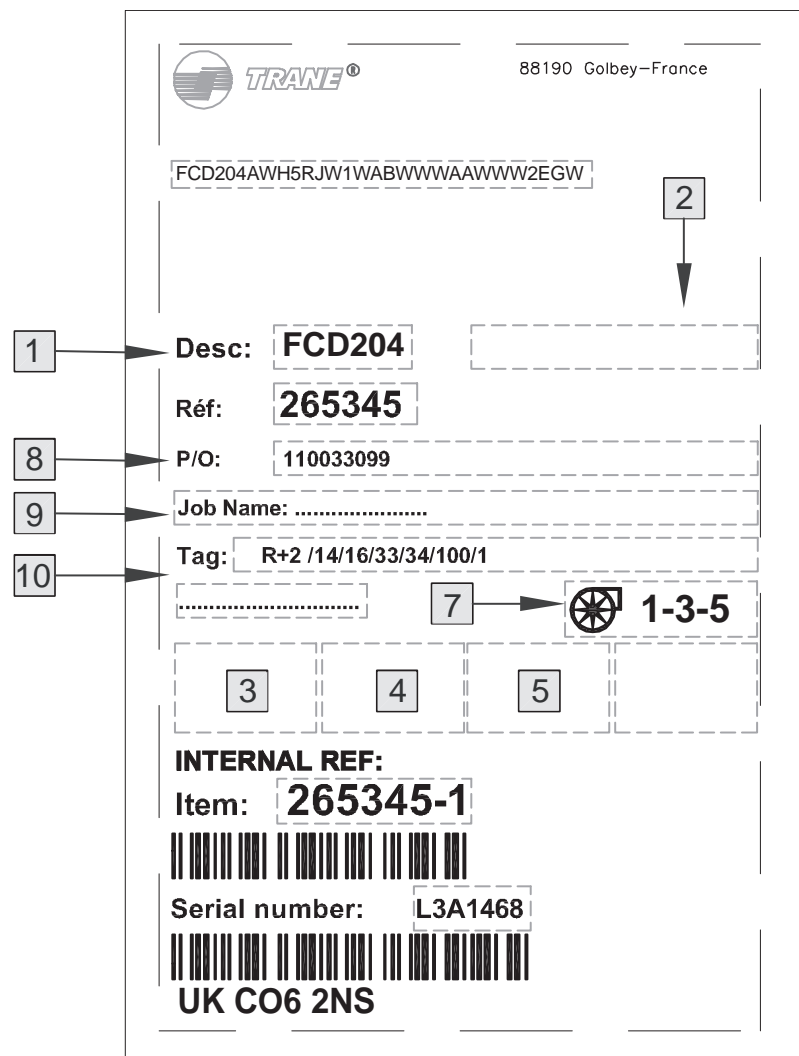

The sticker contains the following information:

- TRANE logo and 88190 Golbey-France
- Model number: FCD204AWH5RJW1WABWWWAWWW2EGW
- Desc: FCD204
- Réf: 265345
- P/O: 110033099
- Job Name: .....
- Tag: R+2 /14/16/33/34/100/1
- Symbol: 1-3-5 (with a wheel icon)
- INTERNAL REF: Item: 265345-1
- Serial number: L3A1468
- UK CO6 2NS









Numbered callouts on the left side of the sticker:

- 1: Points to the 'Desc:' field.
- 8: Points to the 'P/O:' field.
- 9: Points to the 'Job Name:' field.
- 10: Points to the 'Tag:' field.
- 3, 4, 5: Point to three empty boxes below the tag field.
- 7: Points to the wheel symbol.
- 2: Points to a dashed box above the 'Desc:' field.





# Installation

① = Indicates the unit description





② = Indicates the ZN control configuration program

<b>2</b>		2-pipe cooling only	<b>4</b>	4-pipe
<b>2</b>		2-pipe heating only		Zone control
<b>2</b>		2-pipe cooling + electric heater		Cascade control
<b>2</b>		2-pipe changeover, 2-way valve		
<b>2</b>		2-pipe changeover, 3-way valve		
<b>2</b>		2-pipe changeover + electric heater, 2-way valve		
<b>2</b>		2-pipe changeover + electric heater, 3-way valve		



③ = Indicates the unit handing

	Water Right hand + Electric Right connection
	Water Left hand + Electric Right connection
	Water Right hand + Electric Left connection
	Water Left hand + Electric Left connection



④ = Indicates the coil type

	Standard coil
	2-pipe high capacity coil
	4-pipe standard coil
	4-pipe high capacity coil

⑤ = Indicates the presence of an electric heater

	Electric heater. If nothing, no electric heater
	Electric heater with electro-mechanical relay
	Electric heater with solid-state relay

⑦ = Indicates the factory-wired fan speeds (AC motor) or presence of EC motor

	3 - 4 - 5	1 = Low speed 3 = Medium speed 5 = High speed
		Indicates presence of EC motor

⑧ = Indicates customer order number (max 25 alphanumeric characters)

⑨ = Indicates job name (max 25 alphanumeric characters)

⑩ = Indicates personal customer tag (max 22 alphanumeric characters)

# Installation

## General data

**Table 1 - General data - FCD without air connections**

230V/50Hz/1pH, Reversible coil, 2 Pipes

Speed at ESP = 0Pa	Unit size	101	103	203	204	304	306	406	408	508	512	612	721
Airflow (1)	(m <sup>3</sup> /h)	188	271	321	415	438	642	642	1004	1110	1329	1411	2031
Standard coil, cooling mode		Air inlet conditions : 27°C/47%, Water : 7/12°C, Constant delta T°											
Total/sensible cooling capacity (1)	(kW)	1.3/0.97	1.7/1.3	1.6/ 1.3	1.9/1.6	2.8/2.1	3.7/2.8	4.1/3.1	5.5/4.3	4.9/3.8	5.5/4.4	8.8/6.6	11.1/1.5
EER/Eurovent Energy class (2)		50/F	53/E	45/F	45/F	53/E	58/E	65/E	58/E	50/F	33/G	49/F	39/F
Water flow (1)	(l/s)	0.062	0.081	0.076	0.091	0.13	0.18	0.2	0.26	0.24	0.26	0.42	0.53
Water pressure drop (1)	(kPa)	16	24.8	5.8	8	13	21.6	25.3	42.9	45.8	55.3	40.9	42.5
Water content	(l)	0.5	0.5	0.6	0.6	1.3	1.3	1.5	1.5	1.5	1.5	2.8	3.3
Water connection		1/2" ISO R7 female gas						3/4" ISO R7 female gas					
Standard coil, heating mode		Air inlet : 20°C, Water inlet : 50°C, Water flow from cooling mode											
Heating capacity (1)	(kW)	1.5	1.9	2.3	2.8	3.5	4.8	5.2	7.3	6.8	7.8	10.2	14.2
COP/Eurovent Energy class (2)		55/E	59/E	66/E	63/E	67/E	75/D	78/D	72/D	64/E	45/F	54/E	49/F
Water flow (1)	(l/s)	0.062	0.081	0.076	0.091	0.13	0.18	0.2	0.26	0.24	0.26	0.42	0.53
Water pressure drop (1)	(kPa)	13.1	20.7	4.8	6.7	13.6	23	20.6	35.2	38.7	46.8	35.6	39.5
<b>Electric heater (option)</b>													
Electric heater	(W)	NA	500	500/750	500/1000	500/1500	500/1500	500/1500	1500/4000	1500/3000	1500/4000	1500/4000	1500/4000
Power supply	(V-Ph-Hz)	230-1-50	230-1-50	230-1-50	230-1-50	230-1-50	230-1-50	230-1-50	230-1-50	230-1-50	230-1-50	230-1-50	230-1-50
Power absorbed (speeds 1/3/5)	(W)	11/16/27	18/25/40	19/26/41	23/37/54	26/42/61	36/59/82	36/59/82	53/87/118	53/87/124	118/139/164	119/145/171	152/184/289
Absorbed current (min/max)	(A)	-	2.2	2.2/3.3	2.2/4.3	2.2/6.5	2.2/6.5	2.2/6.5	6.5/17.4	6.5/13	6.5/17.4	6.5/17.4	6.5/17.4
<b>Fan motor</b>													
Maximun external static pressure	(Pa)	40	60	60	60	90	90	90	90	90	90	90	90
<b>Sound levels</b>													
Sound power level (speeds 2/3/5) (3)	(dB(A))	28/32/42	40/47/54	41/47/54	39/49/ 56	38/47/53	43/53/59	46/55/61	45/54/60	45/56/61	52/59/64	50/58/63	49/64/53
Sound pressure level (speeds 2/3/5) (4)	(dB(A))	19/23/33	31/38/45	32/38/45	30/40/47	29/38/44	34/44/50	37/46/52	36/45/51	36/47/52	43/50/55	41/49/54	40/55/44
NR Level (speeds 2/3/5) (4)		17/17/25	28/34/40	29/34/40	27/37/43	25/34/40	30/41/47	34/43/48	31/40/46	32/43/48	36/45/51	35/43/49	36/50/39
NC Level (speeds 2/3/5) (4)		16/15/23	26/33/39	27/33/39	26/35/41	23/32/39	29/39/45	32/41/46	29/38/44	30/41/46	35/44/49	34/41/47	34/49/38

Speed 1/3/5 -> speed low/medium/high

(1) At high speed acc. to Eurovent conditions

(2) EER Eurovent ratio and class definition (speed low/medium/high)

(3) Levels according to Eurovent specification 8/2 (ISO 3741/88) and Eurovent FC Certification

(4) Values calculated from sound levels with hypothetical acoustic attenuation of 9dB



# Installation

**Table 2 - General data - FCD with inlet/discharge air connections (Dia. 200mm) and EU3 filter**

230V/50Hz/1pH, Reversible coil, 2 Pipes

Speed at ESP = 50Pa	Unit size	204 (*)	304 (*)	306	406	408	508	512	612	721
Airflow (1)	(m3/h)	145	152	402	400	544	585	864	869	1990
Standard coil, cooling mode		Air inlet conditions : 27°C/47%, Water : 7/12°C, Constant delta T°								
Total/sensible cooling capacity (1)	(kW)	0.84/0.68	1.2/0.85	2.6/2	2.9/2.1	3.7/2.7	3.3/2.4	4.3/3.3	6.3/4.5	11/8.4
EER/Eurovent Energy class (2)		24/E	28/D	42/C	47/C	41/C	35/D	32/D	45/C	40/D
Water flow (1)	(l/s)	0.04	0.056	0.13	0.14	0.18	0.16	0.2	0.3	0.53
Water pressure drop (1)	(kPa)	1.9	2.5	11.6	13.5	20.7	22.2	35.2	22.1	41
Water content	(l)	0.6	1.3	1.3	1.5	1.5	1.5	1.5	2.8	3.3
Water connection		1/2" ISO R7 female gas					3/4" ISO R7 female gas			
Standard coil, heating mode		Air inlet : 20°C, Water inlet : 50°C, Water flow from cooling mode								
Heating capacity (1)	(kW)	1.2	1.4	3.3	3.5	4.5	4.2	5.7	6.9	14
COP/Eurovent Energy class (2)		32/D	32/D	53/C	56/C	50/C	45/C	42/C	49/C	50/C
Water flow (1)	(l/s)	0.04	0.056	0.13	0.14	0.18	0.16	0.2	0.3	0.53
Water pressure drop (1)	(kPa)	1.5	2.5	10.1	10.9	16.7	18.7	29.7	19.1	38
<b>Electric heater (option)</b>										
Electric heater	(W)	500/1000	500/1500	500/1500	500/1500	1500/4000	1500/3000	1500/4000	1500/4000	1500/4000
Power supply	(V-Ph-Hz)	230-1-50	230-1-50	230-1-50	230-1-50	230-1-50	230-1-50	230-1-50	230-1-50	230-1-50
Power absorbed (speeds 1/3/5)	(W)	23/37/54	26/42/61	36/58/82	36/59/82	53/87/118	53/87/124	118/139/164	119/145/171	146/254/283
Absorbed current (min/max)	(A)	2.2/4.3	2.2/6.5	2.2/6.5	2.2/6.5	6.5/17.4	6.5/13	6.5/17.4	6.5/17.4	6.5/17.4
<b>Fan motor</b>										
Maximum external static pressure	(Pa)	50	70	70	70	70	70	70	70	70
<b>Sound levels</b>										
Supply sound power level (speeds 2/3/5) (3)	(dB(A))	39/45/47	38/46/47	45/50/54	42/48/51	42/49/52	46/53/57	50/54/58	47/50/54	39/43/54
Return sound power level (speeds 2/3/5) (3)	(dB(A))	42/48/50	43/49/51	47/52/55	45/50/53	40/47/51	51/56/59	53/56/59	50/53/56	42/46/67
Radiated sound power level (speeds 2/3/5) (3)	(dB(A))	31/40/44	31/40/43	33/42/47	33/41/47	42/48/53	42/48/53	44/48/53	44/49/53	37/41/52
NR Level (speeds 2/3/5) (4)		20/25/27	18/25/27	24/31/34	24/31/34	22/30/34	27/33/36	31/34/37	27/30/33	20/24/34
NC Level (speeds 2/3/5) (4)		18/23/25	16/23/26	23/29/33	23/29/32	20/28/33	25/32/35	29/32/35	26/28/32	18/22/32

Speed 1/5/6 -> speed low/medium/high

(1) At medium speed in compliance with Eurovent conditions

(2) EER Eurovent ratio and class definition (speed (low/medium/high))

(3) Levels according to Eurovent specification 8/2 (ISO 3741/88) and Eurovent FC Certification

(4) Values calculated from sound levels with hypothetical acoustic attenuation of 20dB

(\*) FCD 204/304 performance at speeds 1/4/5 : sound power at speeds 2/3/4



# Installation

**Table 3 - General data - FED without air connections**

230V/50Hz/1pH, Reversible coil, 2 Pipes

Speed at ESP = 0Pa	Unit size	100	200	300	400	500	600
Airflow (1)	(m <sup>3</sup> /h)	310	441	609	1014	1591	1591
Standard coil, cooling mode		Air inlet conditions : 27°C/47%, Water : 7/12°C, Constant delta T°					
Total / sensible cooling capacity (1)	(kW)	1.4 / 1.1	1.9 / 1.6	3.3 / 2.5	5.2 / 4.1	6.1 / 4.9	9.7 / 7.3
FCEER / Eurovent Energy class (2)		186 / B	185 / B	174 / B	133 / A	87 / A	125 / A
Water flow (1)	(l/s)	0.068	0.093	0.16	0.25	0.29	0.46
Water pressure drop (1)	(kPa)	18.3	8.2	15.5	39	60.8	48.2
Water content	(l)	0.5	0.6	1.3	1.5	1.5	2.8
Water connection		1/2" ISO R7 female gas					
Standard coil, heating mode		Air inlet : 20°C, Water inlet : 50°C, Water flow from cooling mode					
Heating capacity (1)	(kW)	1.9	2.7	4.3	6.9	8	11.4
FCCOP / Eurovent Energy class (2)		240 / B	250 / B	138 / A	173 / A	103 / A	42 / A
Water flow (1)	(l/s)	0.068	0.093	0.16	0.25	0.29	0.46
Water pressure drop (1)	(kPa)	15.1	6.9	13.6	38	60	48
<b>Electric heater (option)</b>							
Electric heater	(W)	-	500	500 / 750	1000 / 3000	1000 / 3000	1000 / 3000
Power supply	(V-Ph-Hz)	230-1-50	230-1-50	230-1-50	230-1-50	230-1-50	230-1-50
Power absorbed (speeds 1/3/5)	(W)	3.3/5.8/12	3.7/8.7/19	4.8/18/43	8/39/65	36/112/159	36/112/159
Absorbed current (min/max)	(A)	-	2.2	2.2/3.3	4.3/13	4.3/13	4.3/13
<b>Fan motor</b>							
Maximum external static pressure	(Pa)	50	60	90	90	90	90
<b>Sound levels</b>							
Sound Power Level (speeds 1/3/5) (3)	(dB(A))	32/41/49	35/45/53	37/52/61	42/57/62	56/66/69	56/66/69
Sound Pressure Level (speeds 1/3/5) (4)	(dB(A))	23/32/40	26/36/44	28/43/52	33/49/53	46/56/60	46/56/60
NR Level (speeds 1/3/5) (4)		21/28/36	22/31/40	24/38/49	29/44/49	42/54/56	42/54/56
NC Level (speeds 1/3/5) (4)		19/27/34	20/30/38	22/37/47	27/42/47	40/52/50	40/52/50
<b>Voltage range</b>							
Minimum voltage	(V)	2	2.3	2.6	3	3	3
Maximum voltage	(V)	5.1	5.8	7.6	9	9	7

Speed 1/3/5 -> speed low/medium/high

(1) At high speed in compliance with Eurovent conditions

(2) EER Eurovent ratio and class definition (speed low/medium/high)

(3) Levels according to Eurovent specification 8/2 (ISO 3741/88) and Eurovent FC Certification For 400/500/600 as per voltages declared to Eurovent.

(4) Values calculated from sound levels with hypothetical acoustic attenuation of 9dB

# Installation

**Table 4 - General data - FED with inlet/discharge air connections (Dia. 200mm) and EU3 filter**

230V/50Hz/1pH, Reversible coil, 2 Pipes

Speed at ESP = 50Pa	Unit size	200	300	400	500	600
Airflow (1)	(m <sup>3</sup> /h)	104	376	449	827	963
Standard coil, cooling mode		Air inlet conditions : 27°C/47%, Water : 7/12°C, Constant delta T°				
Total / sensible cooling capacity (1)	(kW)	0.65 / 0.5	2.3 / 1.7	3 / 2.2	4.2 / 3.2	6.8 / 5
EER / Eurovent Energy class (2)		84 / B	100 / A	128 / A	78 / B	110 / A
Water flow (1)	(l/s)	0.031	0.11	0.14	0.2	0.33
Water pressure drop (1)	(kPa)	1.2	8.1	14.4	34.7	25.8
Water content	(l)	0.6	1.3	1.5	1.5	2.8
Water connection		1/2" ISO R7 female gas				
Standard coil, heating mode		Air inlet : 20°C, Water inlet : 50°C, Water flow from cooling mode				
Heating capacity (1)	(kW)	0.81	3	3.6	5.1	7.6
COP / Eurovent Energy class (2)		98 / A	191 / A	148 / A	86 / B	119 / A
Water flow (1)	(l/s)	0.031	0.11	0.14	0.2	0.33
Water pressure drop (1)	(kPa)	0.97	7.1	11.6	20.3	22.4
<b>Electric heater (option)</b>						
Electric heater	(W)	500	500 / 750	1000 / 3000	1000 / 3000	1000 / 3000
Power supply	(V-Ph-Hz)	230-1-50	230-1-50	230-1-50	230-1-50	230-1-50
Power absorbed (speeds 1/3/5)	(W)	3.7/8.7/19	4.8/18/43	6/25/46	23/69/100	25/76/109
Absorbed current (min/max)	(A)	2.2	2.2/3.3	4.3/13	4.3/13	4.3/13
<b>Fan motor</b>						
Maximum external static pressure	(Pa)	50	70	70	70	70
<b>Sound levels</b>						
Supply sound power level (speeds 2 / 3 / 5) (3)	(dB(A))	32/38/47	39/46/56	36/52/58	47/57/60	47/57/60
Return sound power level (speeds 2 / 3 / 5) (3)	(dB(A))	35/40/48	40/47/56	36/52/58	50/60/63	50/60/63
Radiated sound power level (speeds 2 / 3 / 5) (3)	(dB(A))	29/34/42	31/37/46	32/46/51	40/50/53	40/50/53
NR Level (speeds 2 / 3 / 5) (4)		13/17/25	19/26/36	16/34/39	27/37/40	27/37/40
NC Level (speeds 2 / 3 / 5) (4)		10/15/24	17/25/34	14/32/37	25/35/38	25/35/38
<b>Voltage range</b>						
Minimum voltage	(V)	2.3	2.6	3	3.5	3
Maximum voltage	(V)	5.8	7.6	9	7	7

Speed 1/5/6 -> speed low/medium/high

(1) At medium speed in compliance with Eurovent conditions

(2) EER Eurovent ratio and class definition (speed (low/medium/high))

(3) Levels according to Eurovent specification 8/2 (ISO 3741/88) and Eurovent FC Certification For 400/500/600 as per voltages declared to Eurovent.

(4) Values calculated from sound levels with hypothetical acoustic attenuation of 20dB

# Installation

---

## Operating limits at air side (temperature and airflow)

### Cooling mode

The unit must not be installed in an environment where the temperature exceeds 40°C.

### Heating mode

The discharge air temperature must not exceed 70°C to avoid damaging the internal unit insulation.

The manufacturer recommends to not exceed 55°C discharge air temperature to ensure ideal comfort and avoid air stratification.

## Operating limits at water side

Water pressure must not exceed 15 bar.

Water temperature must not exceed 95°C.

Minimal water temperature depends on glycol percentage.

## Water quality recommendations

At installation and then yearly, the manufacturer recommends having water analyzed for bacteria (ferro-bacteria, bacteria generating H<sub>2</sub>S and reducing sulfates) and also a chemical analysis, to avoid corrosion and scaling. The water circuit must include water treatment devices: filters, additives, intermediate exchangers, purges, vents, isolating valves, etc. depending on the results of these analyses.

### **CAUTION! Proper Water Treatment!**

The use of untreated or improperly treated water in this equipment may result in scaling, erosion, corrosion, algae or slime. It is recommended that the services of a qualified water treatment specialist be engaged to determine what water treatment, if any, is required. Trane assumes no responsibility for equipment failures which result from untreated or improperly treated water, or saline or brackish water

### **CAUTION! Coil recommendation**

Coil must not be used in a corrosive environment, to prevent corrosion of aluminium components. Coated fin is available as an option. Contact your local Trane sales office for advice.

# Installation

## Handling the unit

**WARNING!** Wear protection gloves when handling the unit. When removing the unit from its pallet, do not handle it by pipes, spigots, valves, drain pan, control panel, or fresh air inlet. Take precaution to not damage the unit.

## Mounting the accessories

Mount all accessories before mounting the unit in the ceiling. Each accessory available for the fan coils is supplied with its connection diagram. Follow these instructions. You can obtain additional copies from your local sales office. Possible positions on the unit are shown in Figure 2.

### Fresh air controller

Different fresh air controllers are available as a factory-mounted option.

- D 100 mm duct connection
- D 125 mm duct connection
- Fixed airflow controller 30 m<sup>3</sup>/h for D 100 mm duct
- Fixed airflow controller 45 m<sup>3</sup>/h for D 100 mm duct
- Adjustable controller 60-130 m<sup>3</sup>/h for D 125 mm duct

**CAUTION!** In all cases, the fresh air spigot must be connected to a filtered and pre-treated air supply (i.e. air handling unit)

Constant maximum airflow = -10/+20%

Delta P (upstream/downstream) = 50-200 Pa

Figure 2 - Possible air intake positions

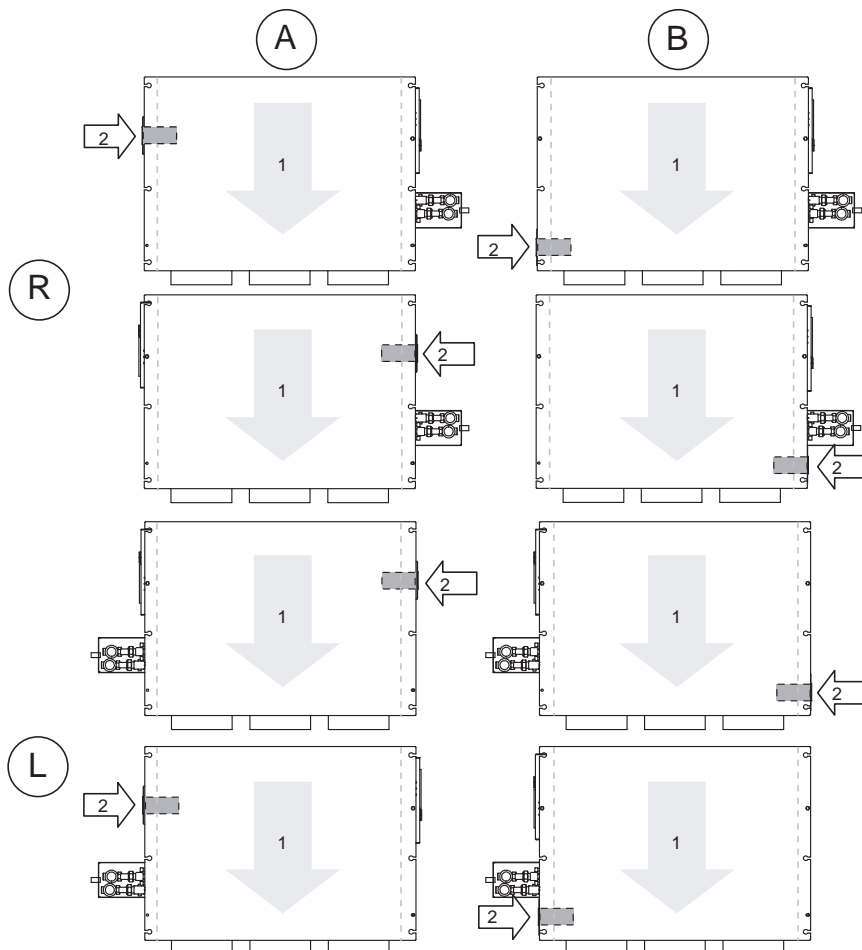

- A = Fresh air duct placed at air intake
- B = Fresh air duct place at air discharge
- L = Left hand configuration
- R = Right hand configuration
- 1 = Airflow
- 2 = Fresh air intake possibility, in compliance with unit size and configuration

# Installation

## Adjusting the 60-130 m<sup>3</sup>/h airflow controller

**WARNING!** Ensure that the plastic membrane is always positioned as indicated in Figure 4.

Adjust the fresh air controller (ø 125 mm only) by placing the two plastic restrictors as indicated in Figure 5.

**Figure 3 - Fresh air adapter**

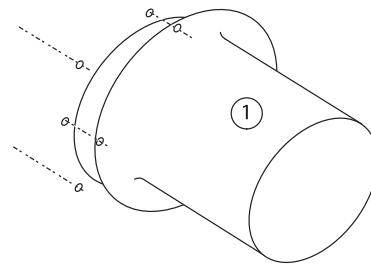

1 = Fresh air controller

**Figure 4 - Fresh air controller membrane**

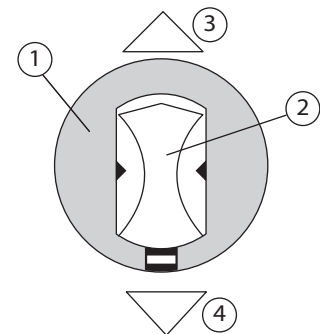

1 = Fresh air controller  
 2 = Membrane  
 3 = Top  
 4 = Bottom

**Figure 5 - Position of restrictors on the 60 to 130 m<sup>3</sup>/h fresh air controller**

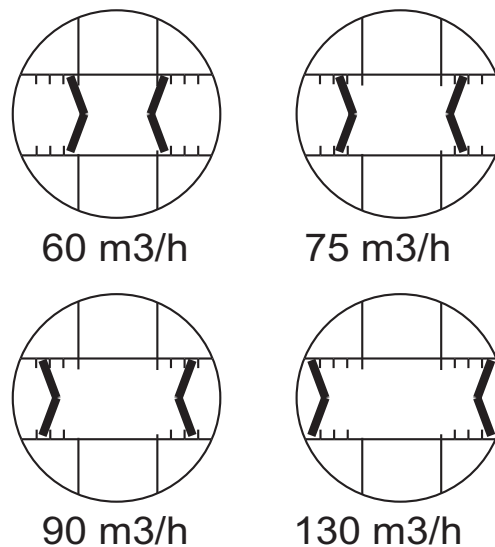

# Installation

## Mounting rubber isolators

4 rubber isolators are supplied, fixed on the drain pan. Mount the isolators on the casing, below the fixation hole, as shown in Figure 6.

**Figure 6 - Mounting rubber isolators**

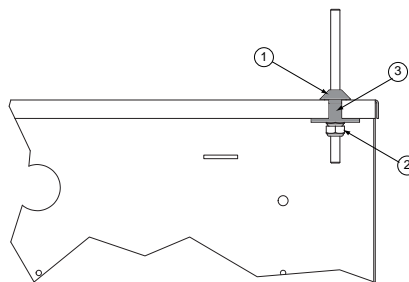

- 1 = Rubber isolator
- 2 = 1 lock nut or 2 nuts
- 3 = Key (fixation) hole

**WARNING!** Do not lift the unit upwards on the threaded rods more than 12 mm when installing or when it is installed. This may cause one or more isolators to come out of position from the unit sheet metal keyhole and the unit could fall.

## Mounting conical water connectors

Two or four conical connectors are supplied with seals, fixed on the drain pan. Place the seal on the connector then screw the connector onto the water valve. Tighten the screw to 25 N.m.

## Mounting flexible hoses

Screw the hoses onto the valve inlets/outlets and connect to water lines.

## Mounting the condensate pump kit

Refer to the notice supplied with the accessory.

## Mounting the unit in the ceiling

Two methods can be used to mount the unit in the ceiling. A minimum of 3 fixation points are necessary up to the unit size 408. When there are 3 fixation points, place two screws on one side of the unit, and one centered on the opposite side.

1. The unit is held against the ceiling using an elevator and is fixed with a cartridge drill.
2. The threaded rods are fixed to the ceiling first, and then the unit is hung on the rods.

Units are to be suspended from the ceiling on threaded rods or lag screws supplied by the installer. The holes are located on the top of the unit. Refer to Table 5 for drilling distances and to Figure 7 for hole locations.

Drill into the ceiling according to the dimensions shown in Figure 7.

Fix the 3 or 4 suspension rods or lag screws into the ceiling.

Units can be placed against the ceiling. Design enough space between 2 units for maintenance (control box, water connections and drain pan access. See Figure 8.

# Installation

**Figure 7 - Hole locations**

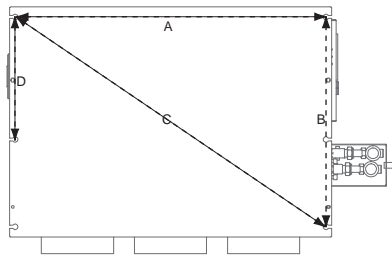



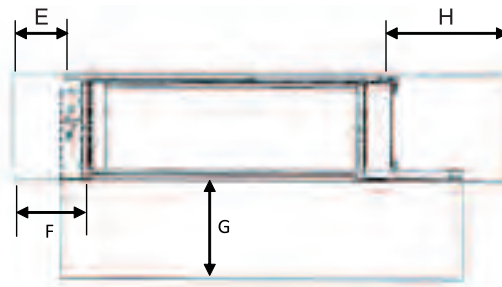





**Figure 8 - Clearance recommendations**



	E (mm)	F (mm)	G (mm)	H (mm)
FCD 101-103-203-204-304-306-406-408-508-512-612 FED 100-200-300-400-500-600	141	143	210	276
FCD 721	141	143	255	253

**Table 5 - Drilling distances**

	Number of suspension points	A (mm)	B (mm)	C (mm)	D (mm)	Ø hole (mm)	Ø threaded rods (1)
<b>Unit size</b>							
 FCD 101-103 FED 100	3/4	478	463	585.4	338	15.1	6
 FCD 203-204 FED 200	3/4	628	463	713.2	338	15.1	6
 FCD 304-306 FED 300	3/4	858	463	922.2	338	15.1	6
 FCD 406-408 FED 400	3/4	1008	463	1063.2	338	15.1	6
Without air duct connection							
 FCD 101-103 FED 100	3/4	478	579	713.2	338	15.1	6
 FCD 203-204 FED 200	3/4	628	579	713.2	338	15.1	6
 FCD 304-306 FED 300	3/4	858	579	922.2	338	15.1	6
 FCD 406-408 FED 400	3/4	1008	579	1063.2	338	15.1	6
With air duct connection							
FCD 304-306 High capacity FED 300 High capacity	4	858	637	1068.5		15.1	6
With or without air duct connection							
FCD 406-408 High capacity FED 400 High capacity	4	1008	637	1192.5		15.1	6
FCD 508-512-FED 500	4	1158	637	1321.5		15.1	6
FCD 612-FED 600	4	1458	637	1591		15.1	6
FCD 721	4	1458	729	1630		15.1	6

(1) If the threaded rod diameter is smaller than 6 mm, use a washer.

# Installation

Mount the unit, with a slight slope towards the drain pan outlet as shown in Figures 9 and 10. Ensure that sufficient service access is provided around the unit for maintenance.

**CAUTION!** If the unit is not mounted with a slight slope, the condensates will not drain correctly through the hole provided. Refer to Figures 9 and 10. In order to be sure that the unit is correctly installed, it is highly recommended to make a test filling in the drain pan with water and make sure that water does not overflow.

**Figure 9**

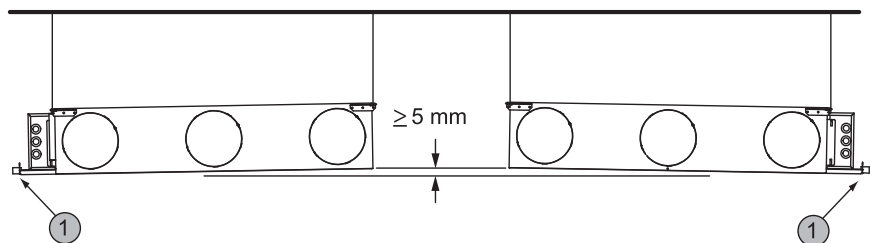

1 = Drain pan outlet

**Figure 10**

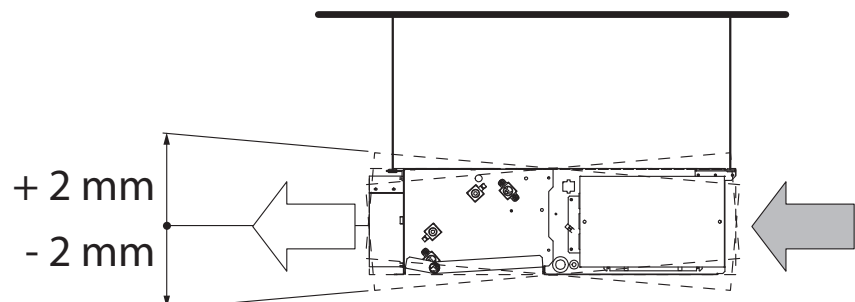



# Installation





## Ductwork connection

Tables 6-7 list all the possible connections.

Ducts must be connected to spigots by means of duct tape. They must never be screwed. Make sure that the entire spigot surface area is covered. Push the duct as far as possible onto the spigot towards the unit to get the best air tightness.





All open spigots should be connected to ceiling grilles or diffusers using normally equal duct runs to minimize the damping requirements at the grilles. Unused spigots must be sealed. To ensure maximum performances of the unit, the ductwork must be as short as possible, with a minimum number of bends.

**Table 6 - Inlet and outlet connections - FCD**

	101	103	203	204	304	306	406	408	508	512	612	721
Circular connection $\varnothing$ 160 mm 	1 or 2	2	2	2	2 or 3	3	3 or 4	4	4 or 5	5	5 or 6	-
Circular connection $\varnothing$ 200 mm 	1	1	1 or 2	1 or 2	1 or 2	2 or 3	2 or 3	2 or 3	2 or 3	3 or 4	3 or 4	5
Oblong connection, equivalent $\varnothing$ 250 mm 	1	1	1	1	1 or 2	1 or 2	1 or 2	2	2 or 3	2 or 3	2 or 3	3 or 4
Rectangular connection for (39 mm deep) 	194 x 418 mm		194 x 568 mm		194 x 798 mm		194 x 948 mm		194 x 1098 mm		194 x 1398 mm	238 x 1398 mm
Rectangular connection for Trane discharge grille (80 mm deep) 	152 x 403 mm		152 x 503 mm		152 x 803 mm		-		-		-	

# Installation

**Table 7 - Inlet and outlet connections - FED**

	FED 100	FED 200	FED 300	FED 400	FED 500	FED 600
Circular connection $\varnothing$ 160 mm 	1 or 2	2	2 or 3	3 or 4	4 or 5	5 or 6
Circular connection $\varnothing$ 200 mm 	1	1 or 2	2 or 3	2 or 3	2 or 3	3 or 4
Oblong connection, equivalent $\varnothing$ 250 mm 	1	1	1 or 2	1 or 2	2	2
Rectangular connection for (39 mm deep) 	194 x 418 mm	194 x 568 mm	194 x 798 mm	194 x 948 mm	194 x 1098 mm	194 x 1398 mm
Rectangular connection for Trane discharge grille (80 mm deep) 	152 x 403 mm	152 x 503 mm	152 x 803 mm	-	-	-

# Installation

## Water connection

Refer to Figure 11 to locate and identify the inlet and outlet water connections.

**CAUTION!** The coil headers are not designed to withstand the torque necessary to tighten the connector. Use a suitable counter-spanner. Tighten to torque 25 N.m

The water inlet is on the bottom of the coil and the water outlet is on the top of the coil.

On 4-pipe coils, the heating connections are located on the right hand side of the coil (see Figure 11).

Figure 11 - Vent and drain positions on straight or inclined coil

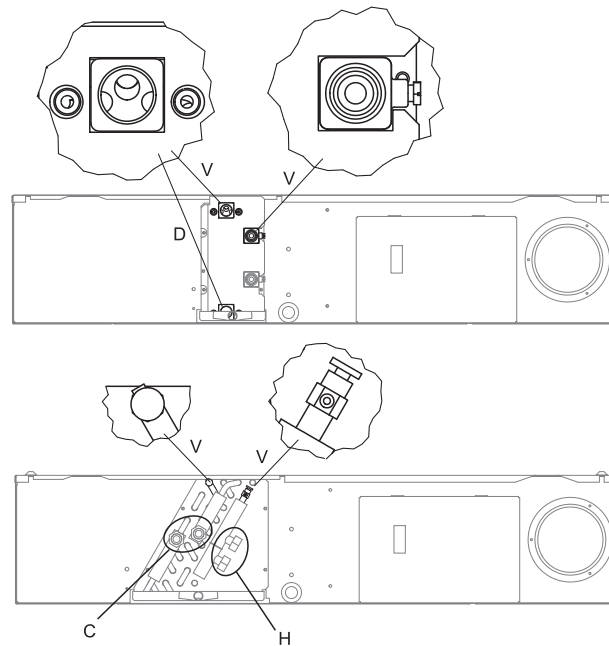

V = Vent  
D = Drain  
C = Cooling piping  
H = Heating piping



# Installation

**Table 8 - Water connection types and diameters**

W = Without valve

Unit size	101/103	203/204	304/306	406/408	508/512	612	721
<b>Standard 2-pipe coil</b>							
Customer connection	Ø1/2" Gas	Ø1/2" Gas	Ø1/2" Gas	Ø1/2" Gas	Ø1/2" Flat gasket	Ø3/4" Flat gasket	Ø3/4" Flat gasket
<b>High Efficiency 2-pipe coil</b>							
Customer connection	Ø1/2" Gas	Ø1/2" Gas	Ø1/2" Flat gasket	Ø1/2" Flat gasket	Ø1/2" Flat gasket	Ø3/4" Flat gasket	Ø3/4" Flat gasket
<b>Standard 4-pipe coil</b>							
Customer connection cooling circuit	Ø1/2" Gas	Ø1/2" Gas	Ø1/2" Gas	Ø1/2" Gas	Ø1/2" Flat gasket	Ø3/4" Flat gasket	Ø3/4" Flat gasket
Customer connection heating circuit	Ø1/2" Gas	Ø1/2" Gas	Ø1/2" Gas	Ø1/2" Gas	Ø1/2" Flat gasket	Ø1/2" Flat gasket	Ø1/2" Flat gasket
<b>High Efficiency 4-pipe coil</b>							
Customer connection cooling circuit	Ø1/2" Gas	Ø1/2" Gas	Ø1/2" Flat gasket	Ø1/2" Flat gasket	Ø1/2" Flat gasket	Ø3/4" Flat gasket	Ø3/4" Flat gasket
Customer connection heating circuit	Ø1/2" Gas	Ø1/2" Gas	Ø1/2" Flat gasket	Ø1/2" Flat gasket	Ø1/2" Flat gasket	Ø1/2" Flat gasket	Ø1/2" Flat gasket

1 = Free issue valve(s) from customer (terminal block only)

Unit size	101/103	203/204	304/306	406/408	508/512	612	721
<b>Standard 2-pipe coil</b>							
Customer connection	Ø1/2" Flat gasket	Ø1/2" Flat gasket	Ø1/2" Flat gasket	Ø1/2" Flat gasket	Ø1/2" Flat gasket	Ø3/4" Flat gasket	Ø3/4" Flat gasket
<b>High Efficiency 2-pipe coil</b>							
Customer connection	Ø1/2" Flat gasket	Ø1/2" Flat gasket	Ø1/2" Flat gasket	Ø1/2" Flat gasket	Ø1/2" Flat gasket	Ø3/4" Flat gasket	Ø3/4" Flat gasket
<b>Standard 4-pipe coil</b>							
Customer connection cooling circuit	Ø1/2" Flat gasket	Ø1/2" Flat gasket	Ø1/2" Flat gasket	Ø1/2" Flat gasket	Ø1/2" Flat gasket	Ø3/4" Flat gasket	Ø3/4" Flat gasket
Customer connection heating circuit	Ø1/2" Flat gasket	Ø1/2" Flat gasket	Ø1/2" Flat gasket	Ø1/2" Flat gasket	Ø1/2" Flat gasket	Ø1/2" Flat gasket	Ø1/2" Flat gasket
<b>High Efficiency 4-pipe coil</b>							
Customer connection cooling circuit	Ø1/2" Flat gasket	Ø1/2" Flat gasket	Ø1/2" Flat gasket	Ø1/2" Flat gasket	Ø1/2" Flat gasket	Ø3/4" Flat gasket	Ø3/4" Flat gasket
Customer connection heating circuit	Ø1/2" Flat gasket	Ø1/2" Flat gasket	Ø1/2" Flat gasket	Ø1/2" Flat gasket	Ø1/2" Flat gasket	Ø1/2" Flat gasket	Ø1/2" Flat gasket



# Installation

2 = Factory-mounted 2 way valves

Unit size	101/103	203/204	304/306	406/408	508/512	612	721
<b>Standard 2-pipe coil</b>							
Customer leaving water connection	Ø1/2" Gas	Ø1/2" Gas	Ø1/2" Gas	Ø1/2" Gas	Ø1/2" Flat gasket	Ø3/4" Flat gasket	Ø3/4" Flat gasket
Customer entering water connection	Ø1/2" Flat gasket	Ø1/2" Flat gasket	Ø1/2" Flat gasket	Ø1/2" Flat gasket	Ø1/2" Flat gasket	Ø3/4" Flat gasket	Ø3/4" Flat gasket
<b>High Efficiency 2-pipe coil</b>							
Customer leaving water connection	Ø1/2" Gas	Ø1/2" Gas	Ø1/2" Flat gasket	Ø1/2" Flat gasket	Ø1/2" Flat gasket	Ø3/4" Flat gasket	Ø3/4" Flat gasket
Customer entering water connection	Ø1/2" Flat gasket	Ø1/2" Flat gasket	Ø1/2" Flat gasket	Ø1/2" Flat gasket	Ø1/2" Flat gasket	Ø3/4" Flat gasket	Ø3/4" Flat gasket
<b>Standard 4-pipe coil</b>							
Customer leaving cold water connection	Ø1/2" Gas	Ø1/2" Gas	Ø1/2" Gas	Ø1/2" Gas	Ø1/2" Flat gasket	Ø3/4" Flat gasket	Ø3/4" Flat gasket
Customer entering cold water connection	Ø1/2" Flat gasket	Ø1/2" Flat gasket	Ø1/2" Flat gasket	Ø1/2" Flat gasket	Ø1/2" Flat gasket	Ø3/4" Flat gasket	Ø3/4" Flat gasket
Customer leaving hot water connection	Ø1/2" Gas	Ø1/2" Gas	Ø1/2" Gas	Ø1/2" Gas	Ø1/2" Flat gasket	Ø1/2" Flat gasket	Ø1/2" Flat gasket
Customer entering hot water connection	Ø1/2" Flat gasket	Ø1/2" Flat gasket	Ø1/2" Flat gasket	Ø1/2" Flat gasket	Ø1/2" Flat gasket	Ø1/2" Flat gasket	Ø1/2" Flat gasket
<b>High Efficiency 4-pipe coil</b>							
Customer leaving cold water connection	Ø1/2" Gas	Ø1/2" Gas	Ø1/2" Flat gasket	Ø1/2" Flat gasket	Ø1/2" Flat gasket	Ø3/4" Flat gasket	Ø3/4" Flat gasket
Customer entering cold water connection	Ø1/2" Flat gasket	Ø1/2" Flat gasket	Ø1/2" Flat gasket	Ø1/2" Flat gasket	Ø1/2" Flat gasket	Ø3/4" Flat gasket	Ø3/4" Flat gasket
Customer leaving hot water connection	Ø1/2" Gas	Ø1/2" Gas	Ø1/2" Flat gasket	Ø1/2" Flat gasket	Ø1/2" Flat gasket	Ø1/2" Flat gasket	Ø1/2" Flat gasket
Customer entering hot water connection	Ø1/2" Flat gasket	Ø1/2" Flat gasket	Ø1/2" Flat gasket	Ø1/2" Flat gasket	Ø1/2" Flat gasket	Ø1/2" Flat gasket	Ø1/2" Flat gasket

# Installation

Whenever the installation's pipes stick out from the auxiliary condensate tray, the installer must insulate them, as indicated in Figure 12.

**CAUTION!** The unit should not operate without a valve. Units have undergone extensive tests for condensates (NF EN 1397 para 5.3), however If a constant water flow is passing through the coil and the fan is not running for a long period of time, condensate may occur in the unit chassis.

**Figure 12 - Water pipe insulation**

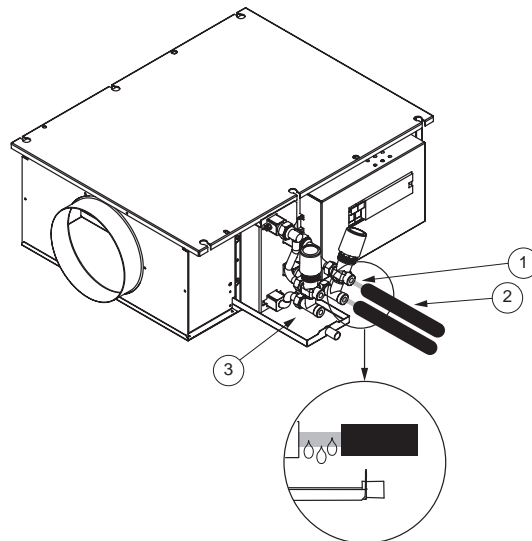

- 1 = water pipe
- 2 = insulation
- 3 = condensate tray

**Figure 13 - Installing a changeover sensor**

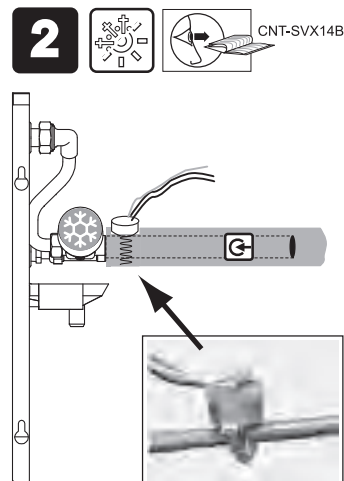

# Installation

## Condensate drainage connection

Provide a U-trap on the drainage line. It is vital to use tubes that do not become deformed when bent.

It is recommended to secure connection between the tube and the drain with a clamp or a collar.

**CAUTION!** Make sure there is no counter-slope or debris which would prevent condensate drainage. (see Figure 14)

*Figure 14 - Single unit condensate drainage*

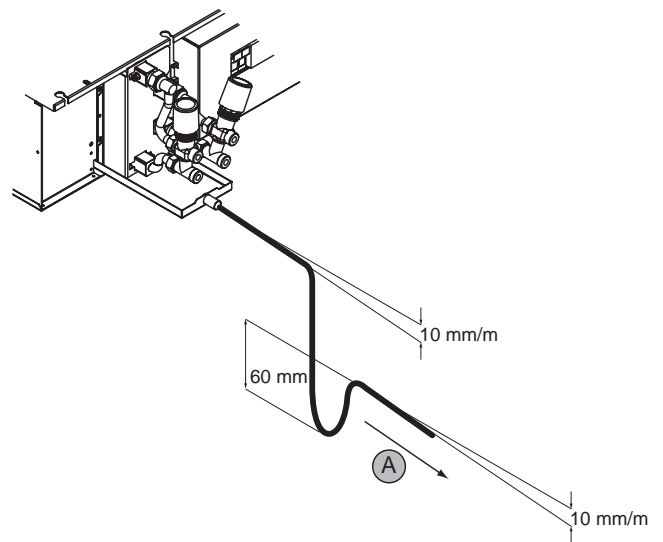

A = To local condensate drain pipe

## Installation

Should several units be connected to the same condensate drain line, respect line design conditions as indicated in Figure 18.

As an option, units can be supplied with a factory-mounted condensate pump. The pump is fitted directly on the condensate tray and can afford a maximum manometric height of 6m (See Figure 15).

The condensate pump is equipped with a floating sensor which will stop chilled water flow as soon as the alarm level is reached, while continuing to evacuate condensate water.

It is recommended to secure connection between the tube and the drain with a clamp or a collar.

**Figure 15 - Condensate pump option for on/off control - general purpose (GP) control**

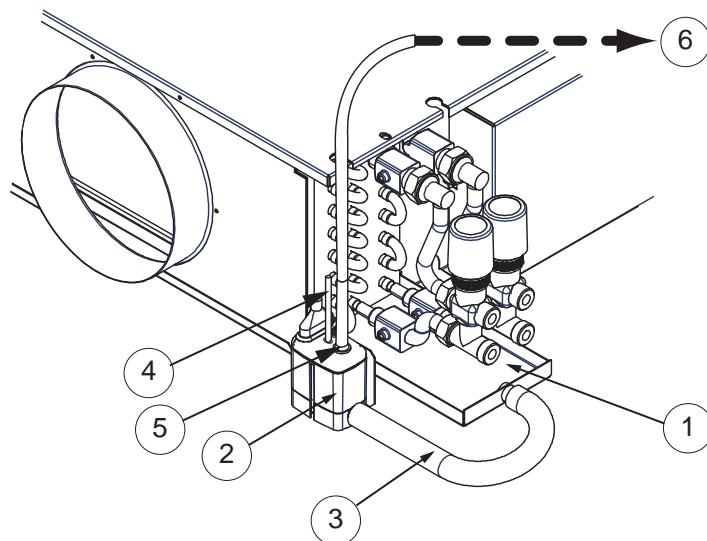

- 1 = Condensate tray
- 2 = Condensate pump
- 3 = Condensate pump suction
- 4 = Vent
- 5 = Condensate pump discharge
- 6 = Towards condensate evacuation



# Installation

Figure 16 - Condensate pump option for ZN control

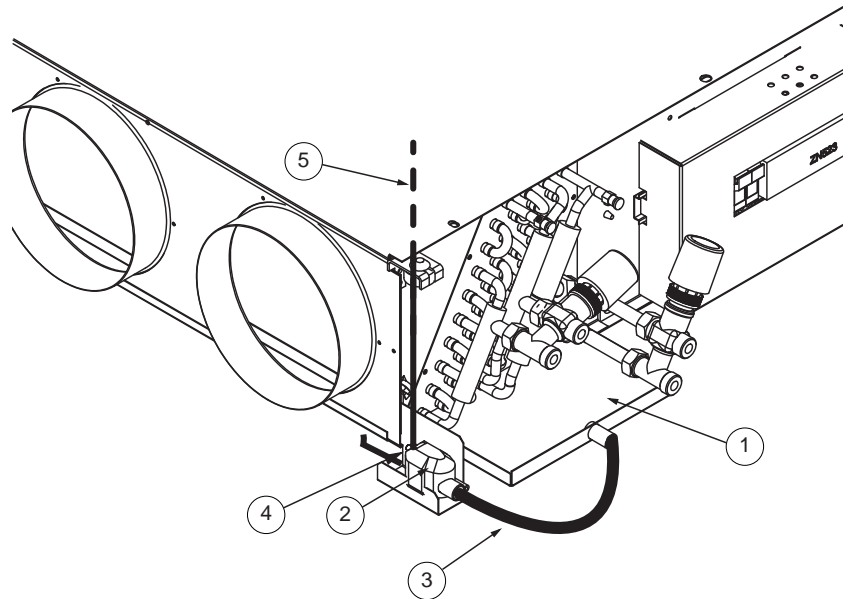

- 1 = Condensate tray
- 2 = Condensate level sensor
- 3 = Condensate tube suction
- 4 = Condensate tube discharge
- 5 = Vent

It is recommended to secure connection between the tube and the drain with a clamp or a collar.

# Installation

**Figure 17 - Condensate drainage with condensate pump for on/off (GP) control or ZN control**

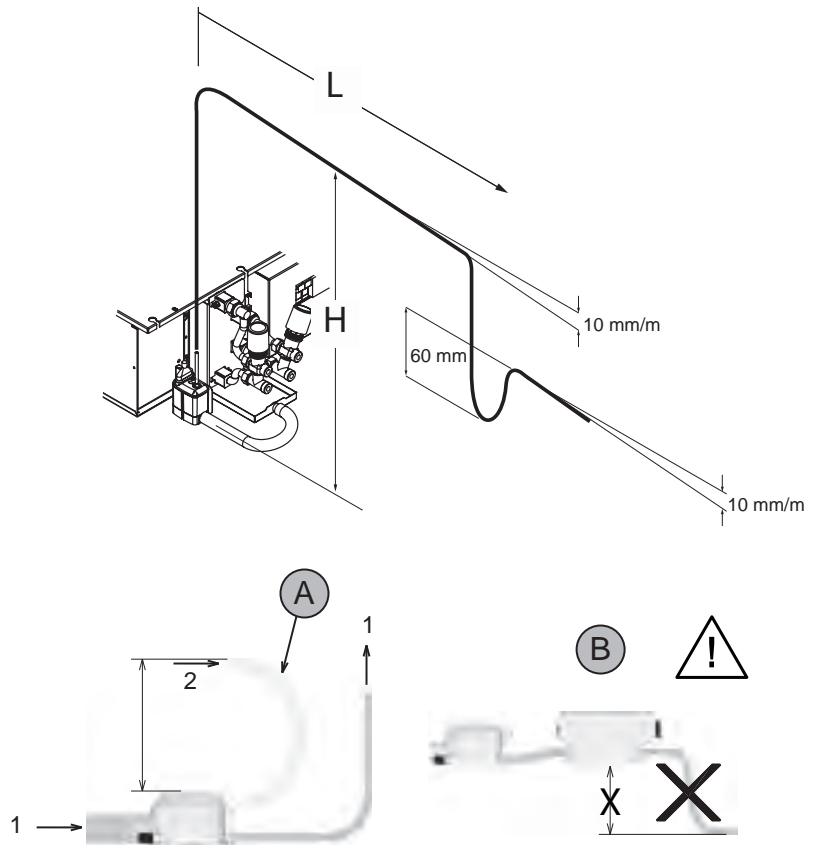

A = Position the vent upwards  
 1 = Water  
 2 = Air  
 B = No negative discharge **WARNING !**

# Installation

**Table 9 - Condensate pump performances (l/h)**

Pump manufacturer	Discharge height - H	Discharge length-L			
		5m	10m	20m	30m
Sauerman GP	1m	9.5	9.0	8.2	7.4
Sauerman GP	2m	7.0	6.5	5.7	4.9
Sauerman GP	3m	5.0	4.6	3.9	3.4
Sauerman GP	4m	4.0	3.6	3.1	2.8
Siccom ZN	1 m	10	9.5	8	7
Siccom ZN	2 m	9	8	7	6
Siccom ZN	3 m	8	7	6	5
Siccom ZN	4 m	6.5	5	4	4

**Figure 18 - Multiple units drainage**

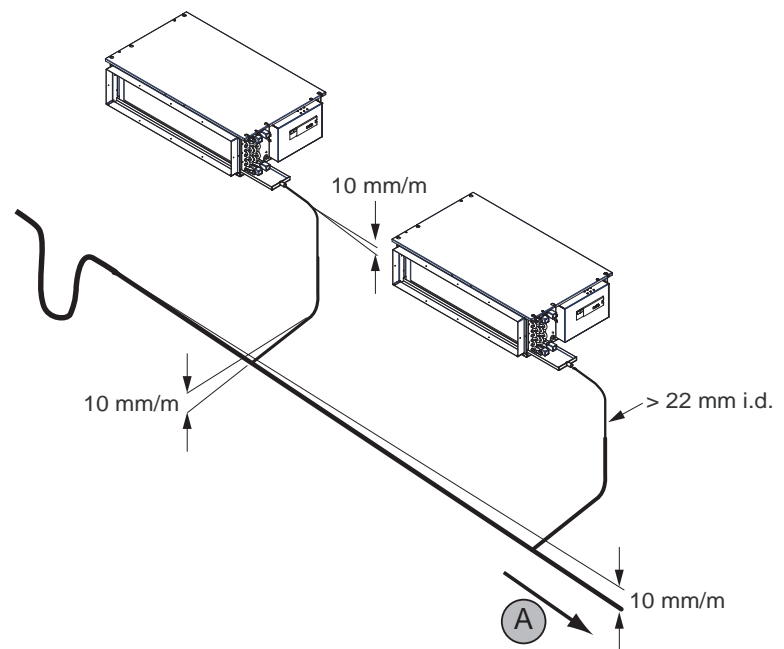

A = To local drainage pipe

# Installation

## Electrical connection

All electrical connections have to be made on the terminal blocks of the main electrical control box indicated in Figure 19.

**WARNING!** Disconnect the power supply before making electrical connections. Failure to do so may cause serious injuries as well as irreversible damage to certain electrical components (motors, relays, etc..).

**WARNING!** Use copper conductors only. Unit terminals are not designed to accept other types of wiring. Aluminium or other materials could lead to galvanic corrosion or overheating at the contact point thus damaging the unit. The customer's electrical connections must comply with current standards.

FCD/FED fan coils manufactured by Trane comply with CEI regulations. The sensors and changeover capsules must be installed on the installation's entering water piping (responsibility of the installer).

The factory-mounted electric heaters are fitted with a safety device that prevents them from functioning if the fan breaks down (beware of automatic resetting systems). All faults must be reported to the maintenance department.

As an option, the control box can be fitted on the opposite side to the water connections.

**WARNING!** If an electric heater is connected by an installer, operation of the electric heater must be subordinated to operation of the fan.

All power supply wiring must be sized and selected in accordance with local code and regulation.

Fast-acting circuit breaker, which is sensitive to very low levels of current leakage to ground (max 30mA) must be installed as a general line protection.

Only copper conductors (1.5mm<sup>2</sup> min) must be used as unit terminals are not designed to accept other types of wiring.

Unit head circuit breaker terminals must be tight to 1.2 N.m torque.

**Figure 19 - Control box location**

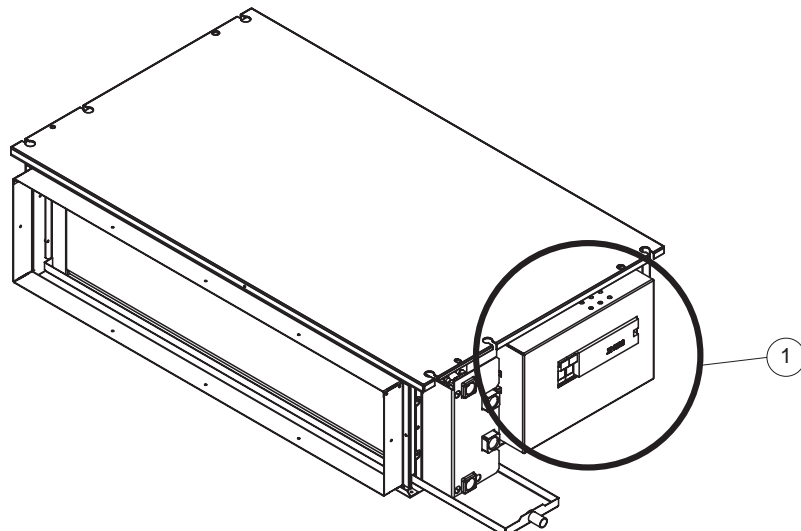

1 = Main electrical control box (following the control required)

# Installation

**Table 10 - Minimum airflow (m3/h) in order to not damage heating elements - FCD**

	Size	101	103	203	204	304	306	406	408	508	512	612	721
Heating capacity	500 W		100	100	80	80	80	80					
	750 W			150	120	120	120	120					
	1000 W				160	160	160	160					
	1500 W					240	240	240	190	190	265	265	375
	2000 W						320	320	250	250	350	350	500
	3000 W								375	375	525	525	750
	4000 W									500	700	700	1000

**Table 11 - Minimum airflow (m3/h) in order to not damage heating elements - FED**

	Unit size	100	200	300	400	500	600
Heating capacity	500W	80	80	80			
	750W		120	120			
	1000W		160	160	160	160	160
	1500W			240	240	240	240
	2000W			320	320	320	320
	3000W				480	480	480

The minimum airflow is ensured for the fan speed selection using the Trane selection tool.

**CAUTION!** Measure airflow above the minimum airflow in the above tables when selecting, on site, a lower speed than those defined from the factory.



# Installation

Electric heaters shall run with the minimum airflow described in following table. To maintain this minimum airflow the fan motor shall not run below the following voltage. This results in reduced airflow operating range described in the following table.

### Minimum air flow (m<sup>3</sup>/h) function electric heater

m <sup>3</sup> /h Unit Size	Electric heater capacity					
	500 W	750 W	1000 W	1500 W	2000 W	3000 W
FED 100	80					
FED 200	80	120	160			
FED 300	80	120	160	240	320	
FED 400			160	240	320	480
FED 500			160	240	320	480
FED 600			160	240	320	480

### Voltage range

2 and 4 pipe cooling or heating

FED100	Voltage	Airflow range
V min	2	100%
V medium	3.6	
V max	5.1	

FED200	Voltage	Airflow range
V min	2.3	100%
V medium	4.1	
V max	5.8	

FED300	Voltage	Airflow range
V min	2.6	100%
V medium	5.1	
V max	7.6	

FED400	Voltage	Airflow range
V min	3	100%
V medium	6.9	
V max	9	

FED500/FED600	Voltage	Airflow range
V min	3.5	100%
V medium	5.2	
V max	7	

### Minimum Voltage

2 pipe electric heat heating mode

FED100	
Electric heater capacity	500 W
V min	2.9
Airflow range	71%

FED200			
Electric heater capacity	500 W	750 W	1000 W
V min	3.2	3.6	3.6
Airflow range	74%	63%	63%

FED300					
Electric heater capacity	500 W	750 W	1000 W	1500 W	2000 W
V min	3.6	3.6	3.6	4.4	4.4
Airflow range	80%	80%	80%	64%	64%

FED400				
Electric heater capacity	1000 W	1500 W	2000 W	3000 W
V min	3	3	3	3
Airflow range	100%	100%	100%	100%

FED500/FED600				
Electric heater capacity	1000 W	1500 W	2000 W	3000 W
V min	3.5	3.5	3.5	3.5
Airflow range	100%	100%	100%	100%

### Example

#### FED 300

Operating range without electric heater or in cooling mode Graph 1

Operating range for electric heater 500 W - 750 W - 1000 W in heating mode Graph 2

Operating range for electric heater 1500 W - 2000 W in heating mode Graph 3

# Installation

**Figure 20 - FED 300 Airflow operating range**

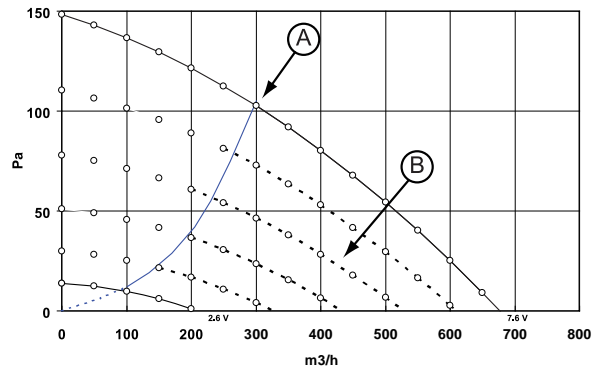

A = Airflow pressure drop system curve  
B = Standard selection operating system zone

**Figure 21 - FED 300 with Electric Heater 500 W - 750 W - 1000 W**

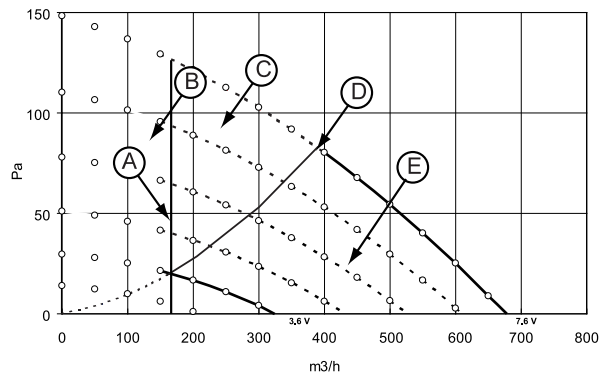

A = 160 m<sup>3</sup>/hr minimum airflow for 1000 W  
B = Not allowed operating system  
C = Special selection operating system zone  
D = Airflow pressure drop system curve  
E = Standard selection operating system zone

**Figure 22 - FED 300 with Electric Heater 1500 W - 2000 W**

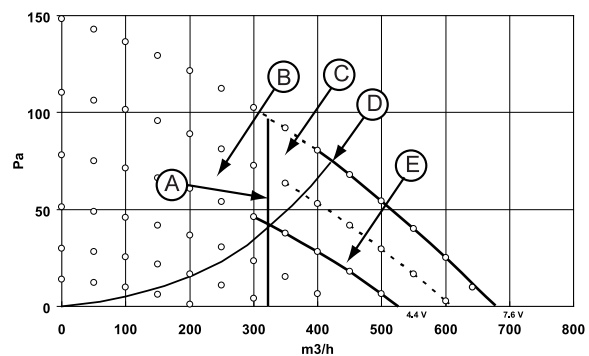

A = 320 m<sup>3</sup>/hr minimum airflow for 2000 W  
B = Not allowed operating system zone  
C = Special selection operating system zone  
D = Airflow pressure drop system curve  
E = Standard selection operating system zone

# Installation

## Connecting the thermostats

For more information about Trane On/Off controls or Trane DDC controls please refer to controls manual.

## Location of thermostats

Do not install thermostats near or above a source of heat (i.e. direct sunlight, hot lamps or radiator). Thermostats should be installed at least 1.5 m above floor level. (see figure 23)

**CAUTION!** To avoid damaging equipment, never connect several fan coils in parallel to one thermostat. Each fan coil must be connected to its own thermostat.

**Table 12 - Available thermostat types - FCD**

	On/Off controls				
	L type	M type	N type	P type	E type
Fan control only	X	X			
Electric heater only			X	X	X
Valve control, 2-pipe cooling or heating			X	X	X
4-pipe			X	X	X
2-pipe auto changeover			X	X	X
2-pipe cooling + electric heater			X	X	X
2-pipe auto changeover + electric heater				X	

**Figure 23 - Thermostats location in room**

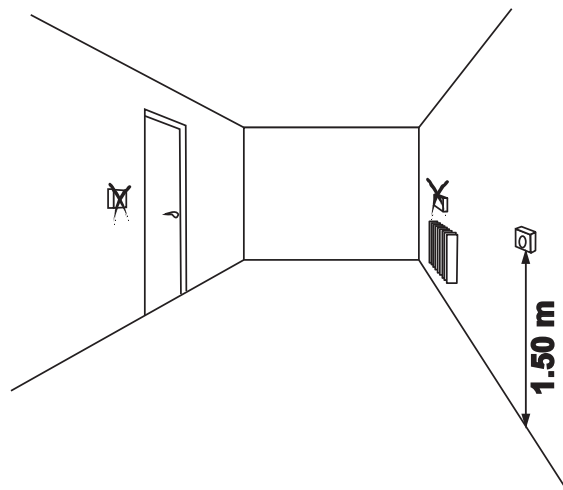



# Installation

## Speed selection

FCD units offer the possibility to select any three from six speeds. Refer to Figures 24-25 to select the speeds to suit the airflow and static pressure required. The speed can be modified directly in the electric control box.

Change the speeds according to the color of the wires (see Figure 24).

Figure 24 - Selecting speeds

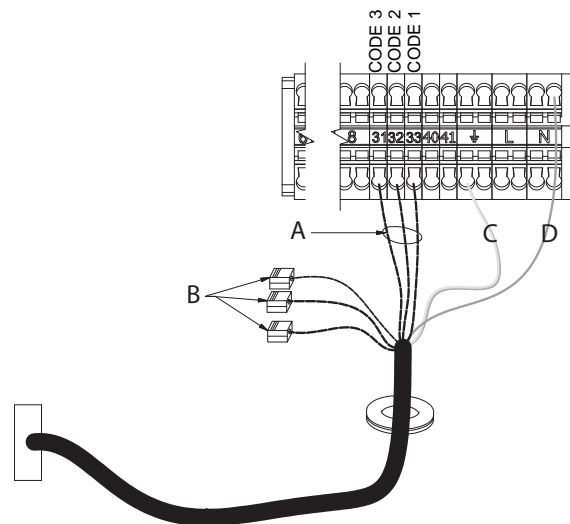

### FCD sizes 101-612:

A = Wire according to color codes. Wire speeds to Terminals 33-32-31.

#### Color coding for speeds:

- Red = speed 1 (Minimum)
- Orange = speed 2
- Purple = speed 3
- Grey = speed 4
- Black = speed 5
- Brown = speed 6
- B = Isolate unused wires
- C = Green/yellow wire
- D = Blue wire

### FCD size 721:

- A = Wire according to color codes.
- Red = speed 1 speed 2 (Minimum)
- Orange = speed 3
- Purple = speed 4
- Grey = speed 5
- Black = cable not available
- Brown = speed 6

Each unit comes with a wiring diagram attached to the unit. Wiring diagram numbers :

Unit without control wiring (only terminal block implemented):

- FCD: wiring diagram 23097592 (2 pipes, 2 pipes + EH) or 23097593 (4 pipes)
- FED: wiring diagram 23099305 (2 pipes, 2 pipes + EH) or 23099306 (4 pipes)

Unit with big empty control box option (box with DIN rail and without terminal block):

- FCD: wiring diagram 23099288
- FED: wiring diagram 23099248

Warning: as big empty control box offer is a particular option proposed to enable customer to mount his own digital direct control and protections, it is the customer/installer's responsibility to make sure that control mounting and wiring is achieved according to local safety regulations (protection selection, earth connection, ...).

# Installation

Figure 25 - Interconnection wirings - On/Off controls - thermostat L/M for FCD

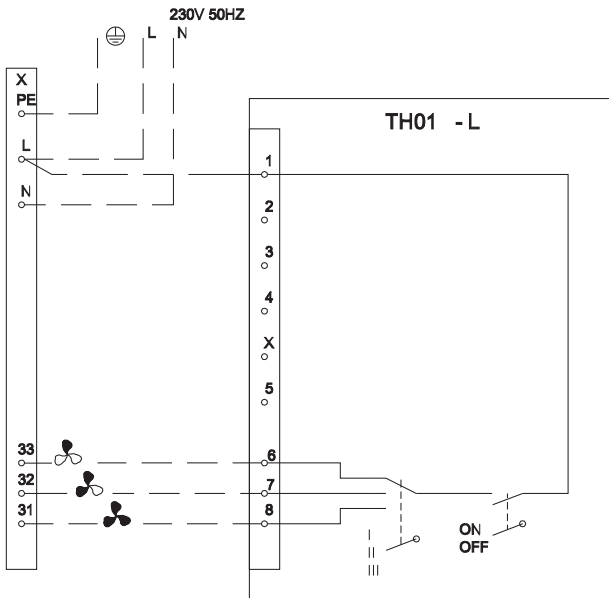

2 TUBES FROID - FROID/CHAUD - 2 TUBES  
CHAUD - 4 TUBES  
2 KALTE ROHRE - KALTE/WARME - 2 WARME  
ROHRE - 4 ROHRE  
2 BUIZEN KOUD - KOUD/WARM - 2 PIPE  
HEATING - 4 PIPE  
2 TUBI FREDDO - FREDDO/CALDO - 2 TUBI  
CALDO - 4 TUBI  
2 BUIZEN KOUD - KOUD/WARM - 2 BUIZEN  
WARM - 4 BUIZEN  
2 TUBOS ENFRIADOR -  
ENFRIADOR/CALENTADOR - 2 TUBOS  
CALENTADOR / 4 TUBOS

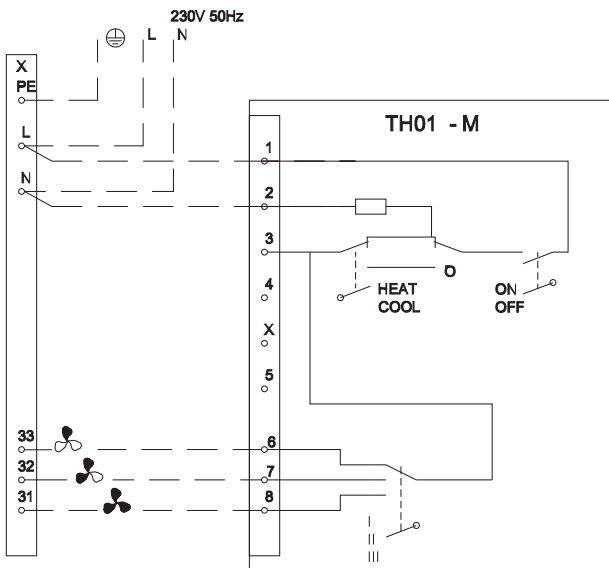

2 TUBES FROID - FROID/CHAUD - 2 TUBES  
CHAUD - 4 TUBES  
2 KALTE ROHRE - KALTE/WARME - 2 WARME  
ROHRE - 4 ROHRE  
2 BUIZEN KOUD - KOUD/WARM - 2 PIPE  
HEATING - 4 PIPE  
2 TUBI FREDDO - FREDDO/CALDO - 2 TUBI  
CALDO - 4 TUBI  
2 BUIZEN KOUD - KOUD/WARM - 2 BUIZEN  
WARM - 4 BUIZEN  
2 TUBOS ENFRIADOR -  
ENFRIADOR/CALENTADOR - 2 TUBOS  
CALENTADOR / 4 TUBOS

ITEM	FRANCAIS	DEUTSCH	ENGLISH
X	BORNIER UNITE	HAUPTKLEMMLEISTE	UNIT TERMINAL BLOCK
TH01	COMMUTATEUR MURAL	RAUM-SCHALTER	WALL SELECTOR
	— — CABLAGE TRANE	TRANE VERDRAHTUNG	TRANE WIRING
	— — CABLAGE CLIENT	VERDRAHTUNG DURCH KUNDEN	CUSTOMER WIRING

ITEM	ITALIANO	NEDERLANDS	ESPAÑOL
X	TERMINALI UNITÀ	UNIT ANNSLUITKLEMMEN BLOCK	TERMINAL UNIDAD
TH01	SELETTORE MURALE	MUURSCHAKELAAR	SELECTOR MURAL
	— — CABLAGGIO TRANE	DOOR TRANE BEDRAAD	CABLEADO TRANE
	— — CABLAGGIO CLIENTE	DOOR KLANT BEDRAAD	CABLEADO CLIENTE

# Installation

Figure 26 - Interconnection wirings - On/Off controls - thermostat N for FCD

2 TUBES FROID (CHAUFFAGE ELECTRIQUE) / 4 TUBES - 2 KALTE ROHRE (ELEKTROHEIZUNG) / 4 ROHRE - 2 BUIZEN KOUD (ELEKTRISCHE VERWARMING) / 4 PIPE - 2 TUBI FREDDO (RISCALDAMENTO ELETTRICO) / 4 TUBI - 2 BUIZEN KOUD (ELEKTRISCHE VERWARMING) / 4 BUIZEN - 2 TUBOS ENFRIADOR (CALEFACCION ELEC) / 4 TUBOS

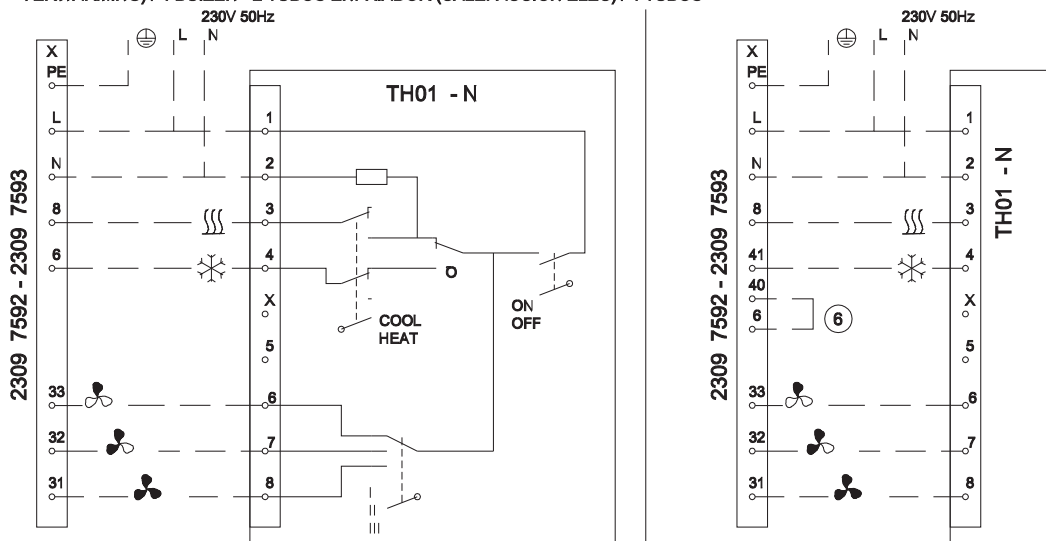

2 TUBES FROID/CHAUD - 2 KALTE/WARME - 2 BUIZEN KOUD/WARM - 2 TUBI FREDDO/CALDO - 2 BUIZEN KOUD/WARM - 2 TUBOS ENFRIADOR/CALENTADOR

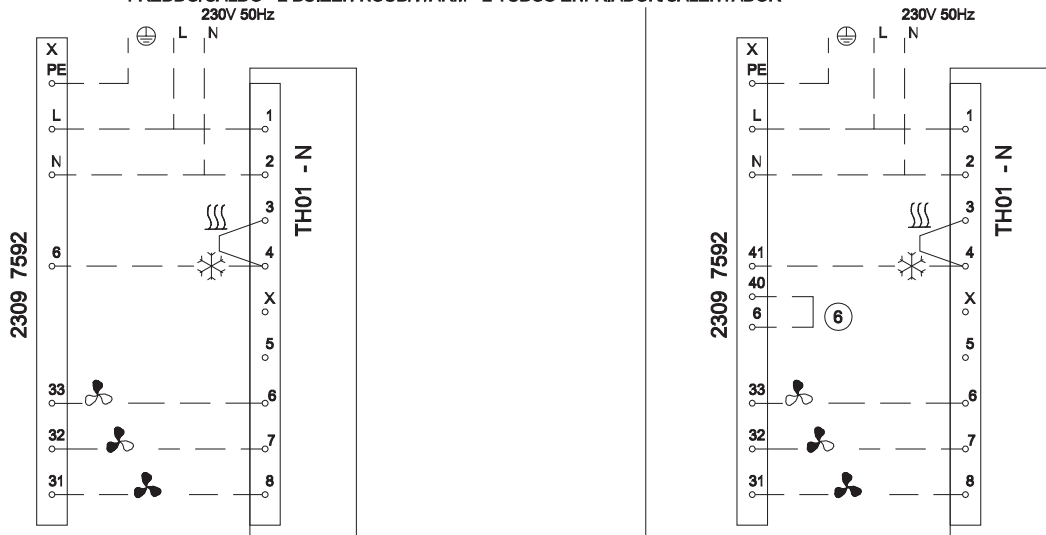

ITEM	FRANCAIS	DEUTSCH	ENGLISH
X...	BORNIER UNITE	HAUPTKLEMMLEISTE	UNIT TERMINAL BLOCK
TH01	THERMOSTAT MURAL	RAUM-THERMOSTATSET	WALL THERMOSTAT
Ⓞ	POMPE A CONDENSATS	WASSER PUMP VERDAMP. KONDENSAT	CONDENSATE LIFT PUMP

— — —	CABLAGE TRANE	TRANE VERDRAHTUNG	TRANE WIRING
— — —	CABLAGE CLIENT	VERDRAHTUNG DURCH KUNDEN	CUSTOMER WIRING

ITEM	ITALIANO	NEDERLANDS	ESPAÑOL
X	TERMINALI UNITÀ	UNIT ANNSLUITKLEMMEN BLOCK	TERMINAL UNIDAD
TH01	TERMOSTATO MURALE	MUURTHERMOSTAAT	TERMOSTATO MURAL
Ⓞ	BOMBA CONDENSAD	CONDENSAATPOMP	POMPA A CONDENSA

— — —	CABLAGGIO TRANE	DOOR TRANE BEDRAAD	CABLEADO TRANE
— — —	CABLAGGIO CLIENTE	DOOR KLANT BEDRAAD	CABLEADO CLIENTE

# Installation

Figure 27 - Interconnection wirings - On/Off controls - thermostat P for FCD

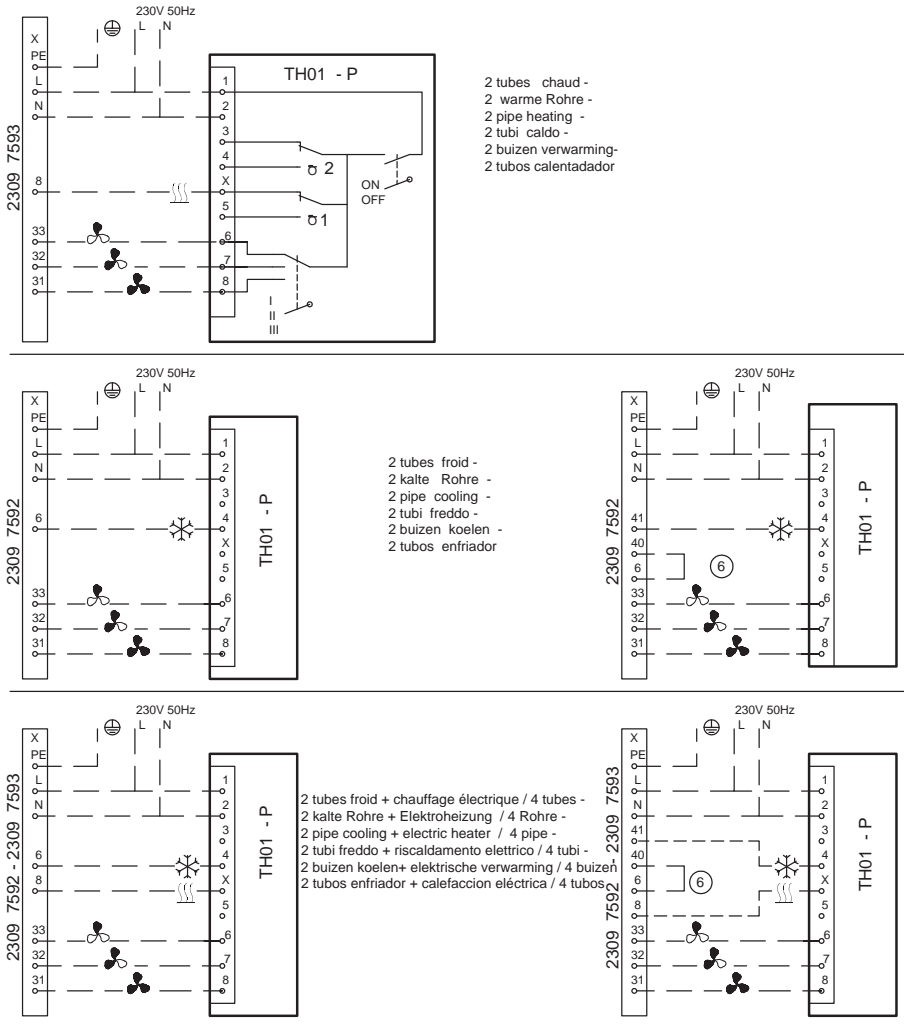

2 tubes chaud -  
2 warme Rohre -  
2 pipe heating -  
2 tubi caldo -  
2 buizen verwarming-  
2 tubos calentador

2 tubes froid -  
2 kalte Rohre -  
2 pipe cooling -  
2 tubi freddo -  
2 buizen koelen -  
2 tubos enfriador

2 tubes froid + chauffage électrique / 4 tubes -  
2 kalte Rohre + Elektroheizung / 4 Rohre -  
2 pipe cooling + electric heater / 4 pipe -  
2 tubi freddo + riscaldamento elettrico / 4 tubi -  
2 buizen koelen+ elektrische verwarming / 4 buizen -  
2 tubos enfriador + calefacción eléctrica / 4 tubos

ITEM	FRANCAIS	DEUTSCH	ENGLISH
X ...	BORNIER UNITE	HAUPTKLEMMLEISTE	UNIT TERMINAL BLOCK
TH01	THERMOSTAT MURAL	RAUM- THERMOSTATSET	WALL THERMOSTAT
⊙	POMPE A CONDENSATS	WASSER PUMP VERDAMP, KONDENSAT	CONDENSATE LIFT PUMP

— — —	CABLAGE TRANE	TRANE VERDRAHTUNG	TRANE WIRING
- - -	CABLAGGIO CLIENTE	VERDRAHTUNG DURCH KUNDEN	CUSTOMER WIRING

ITEM	ITALIANO	NEDERLANDS	ESPAÑOL
X	TERMINALI UNITÀ	UNIT ANNSLUITKLEMMEN BLOCK	TERMINAL UNIDAD
TH01	TERMOSTATO MURALE	MUURTHERMOSTAAT	TERMOSTATO MURAL
⊙	BOMBA CONDENSAD	CONDENSAATPOMP	POMPA A CONDENSA

— — —	CABLAGGIO TRANE	DOOR TRANE BEDRAAD	CABLEADO TRANE
- - -	CABLAGGIO CLIENTE	DOOR KLANT BEDRAAD	CABLEADO CLIENTE

L, M, N, P E = Thermostat type  
 1 : 2-pipe cooling or heating - 4-pipe  
 2 : 2-pipe auto changeover  
 3 : 2-pipe cooling + electric heater  
 4 : Electric heater only  
 5 : 2-pipe auto changeover + electric heater  
 6 : 2-pipe manual changeover  
 7 : Fan control only  
 - - - - Customer wiring  
 Recommended cable size: 5 x 0.9 to 8 x 0.9 mm<sup>2</sup>

# Installation

Figure 28 - Interconnection wirings - On/Off controls - thermostat P for FCD

2 tubes change-over automatique - 2 Rohre automatische umschaltung - 2 pipe automatic change-over - 2 tubi change-over automatico  
 - 2 buizen automatische omschakeling - 2 tubos change-over automatico

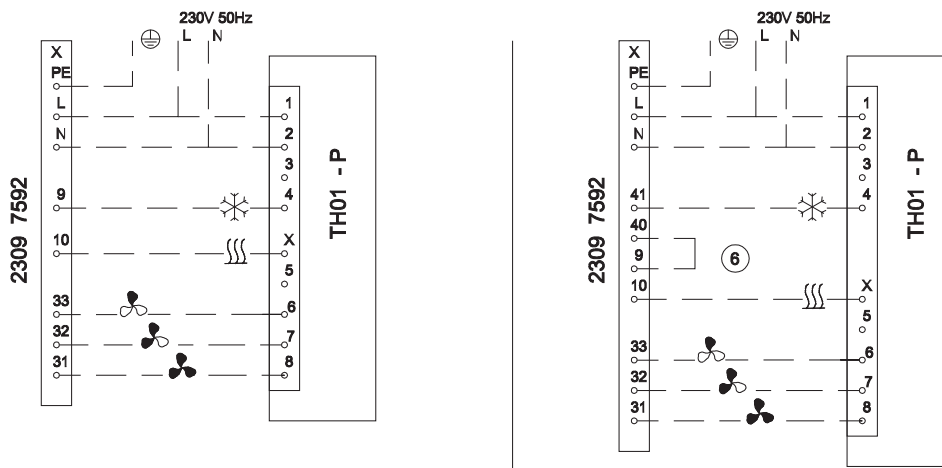

2 tubes change-over automatique + chauffage électrique - 2 Rohre automatische umschaltung + Elektroheizung -  
 2 pipe automatic change-over + electric heater - 2 tubi change-over automatico + riscaldamento elettrico -  
 2 buizen automatische omschakeling + elektrische verwarming - 2 tubos change-over automatico + calefacción eléctrica

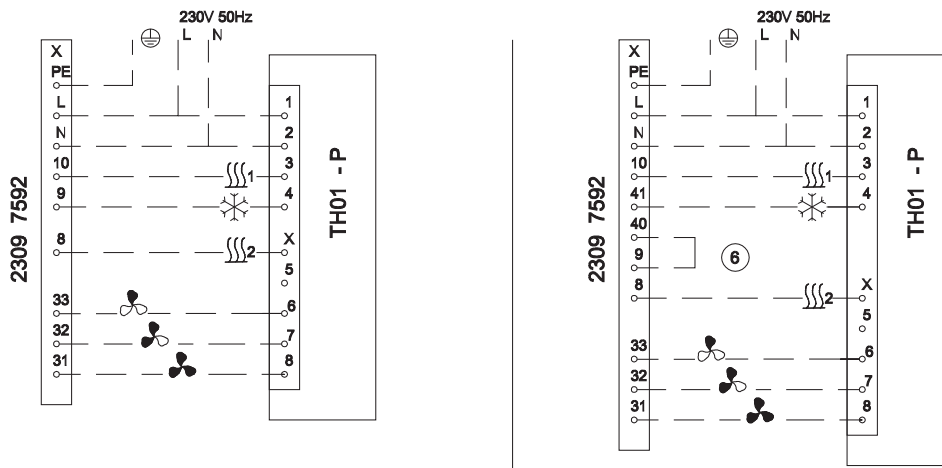

ITEM	FRANCAIS	DEUTSCH	ENGLISH
X ...	BORNIER UNITE	HAUPTKLEMMLEISTE	UNIT TERMINAL BLOCK
TH01	THERMOSTAT MURAL	RAUM- THERMOSTATSET	WALL THERMOSTAT
⑥	POMPE A CONDENSATS	WASSER PUMP VERDAMP. CONDENSAT	CONDENSATE LIFT PUMP

---	CABLAGE TRANE	TRANE VERDRAHTUNG	TRANE WIRING
---	CABLAGE CLIENT	VERDRAHTUNG DURCH KUNDEN	CUSTOMER WIRING

ITEM	ITALIANO	NEDERLANDS	ESPAÑOL
X	TERMINALI UNITÀ	UNIT ANNSLUITKLEMMEN BLOCK	TERMINAL UNIDAD
TH01	TERMOSTATO MURALE	MUURTHERMOSTAAT	TERMOSTATO MURAL
⑥	BOMBA CONDENSAD	CONDENSAATPOMP	POMPA A CONDENSA

---	CABLAGGIO TRANE	DOOR TRANE BEDRAAD	CABLEADO TRANE
---	CABLAGGIO CLIENTE	DOOR KLANT BEDRAAD	CABLEADO CLIENTE

# Installation

Figure 29 - Interconnection wirings - On/Off controls - thermostat P/E for FCD

2 tubes change-over automatique + chauffage électrique + relais pilote - 2 Rohre automatische umschaltung + Elektroheizung + startrelais -  
 2 pipe automatic change-over + electric heater + pilot relay - 2 tubi change-over automatico + riscaldamento elettrico +rele pilota -  
 2 buizen automatische omschakeling + elektrische verwarming + startrelais- 2 tubos change-over automatico + calefaccion eléctrica+ rele piloto.

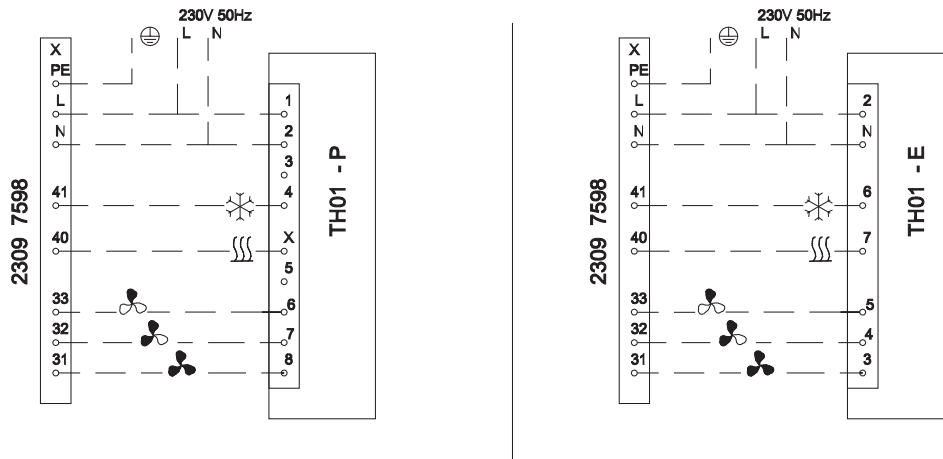

2 tubes change-over à distance + chauffage électrique + relais pilote -  
 2 Rohre umschaltung an d'istanz + Elektroheizung + startrelais -  
 2 pipe remote change-over + electric heater + pilot relay -  
 2 tubi change-over a distanza + riscaldamento elettrico +rele pilota -  
 2 buizen afstandsbesturing+ elektrische verwarming + startrelais-  
 2 tubos change-over a distancia + calefaccion eléctrica+ rele piloto.

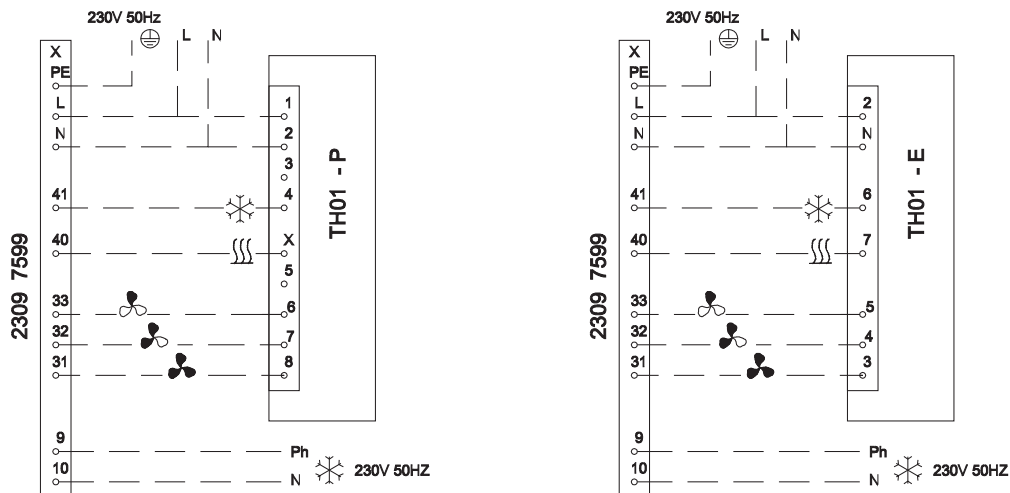

ITEM	FRANÇAIS	DEUTSCH	ENGLISH
X	BORNIER UNITE	HAUPTKLEMMLEISTE	UNIT TERMINAL BLOCK
TH01	THERMOSTAT MURAL	RAUM-THERMOSTATSET	WALL THERMOSTAT
	— CABLAGE TRANE	TRANE VERDRÄHTUNG	TRANE WIRING
	— CABLAGE CLIENT	VERDRÄHTUNG DURCH KUNDEN	CUSTOMER WIRING

ITEM	ITALIANO	NEDERLANDS	ESPAÑOL
X	TERMINALI UNITÀ	UNIT ANNSLUITKLEMMEN BLOCK	TERMINAL UNIDAD
TH01	TERMOSTATO MURALE	MUURTHERMOSTAAT	TERMOSTATO MURAL
	— CABLAGGIO TRANE	DOOR TRANE BEDRAAD	CABLEADO TRANE
	— CABLAGGIO CLIENTE	DOOR KLANT BEDRAAD	CABLEADO CLIENTE

# Installation

## Main power supply

It is the installer's responsibility to ensure that units are protected by an electrical disconnect device such as a fuse or circuit breaker. Standard units with on/off control are supplied without any protection, and a fuse disconnect switch is available as an option. Units with modulating/communicating ZN control are supplied with the fuse disconnect switch factory-mounted as standard. Refer to the wiring diagrams supplied with the units for more information.

To connect main power supply, refer to Figures 30-31.

**Figure 30 - Units with On/Off control**

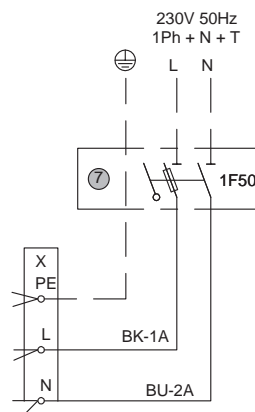

**Figure 31- Units with modulating/communicating control with/without electric heater**

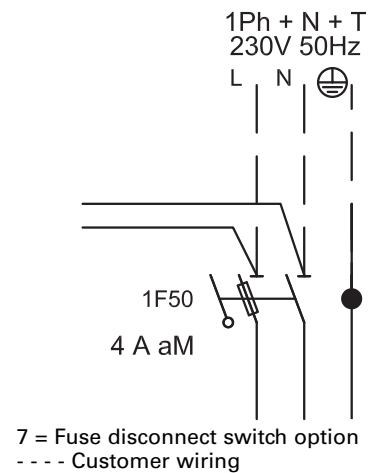

Recommended cable size: 3 x 1.5mm<sup>2</sup> and higher depending on electric heater capacity.

**Table 13 - Fuse size (A) - FCD/FED**

	Without electric heater	With electric heater < 2kW	With electric heater > 2 kW
On/off control	4	16	25
ZN control	4	10	25

**Table 14 - Recommended cable cross-sectional area (mm<sup>2</sup>)**

	Minimum	Maximum
FCD-FED without electric heater	1.5	2.5
FCD-FED with electric heater	2.5	6

# Installation

## External static pressure and airflow curves

**Figure 32 - External Static Pressure - FCD 101 with G3 filter**

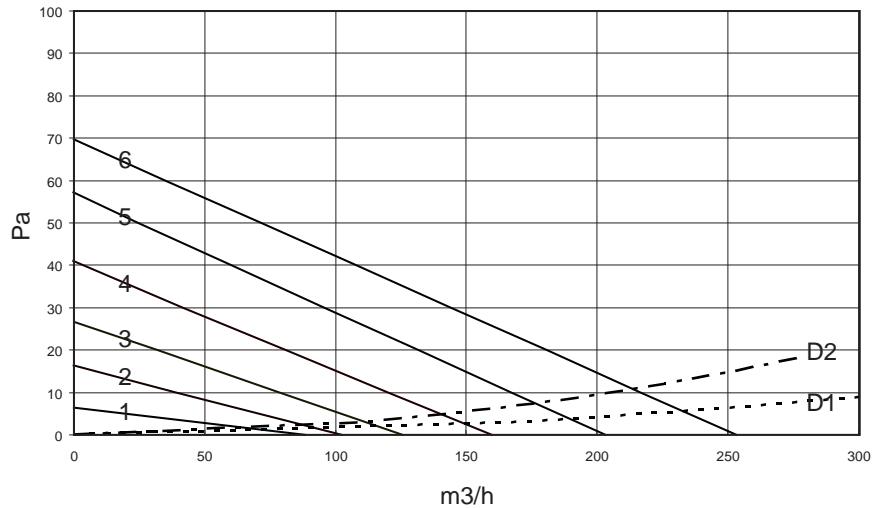

D1 = Discharge plenum only,  $\phi$ 200 mm air duct connection(s)

D2 = Discharge plenum + return plenum,  $\phi$ 200 mm air duct connections(s)

**Figure 33 - External Static Pressure - FCD 103 with G3 filter**

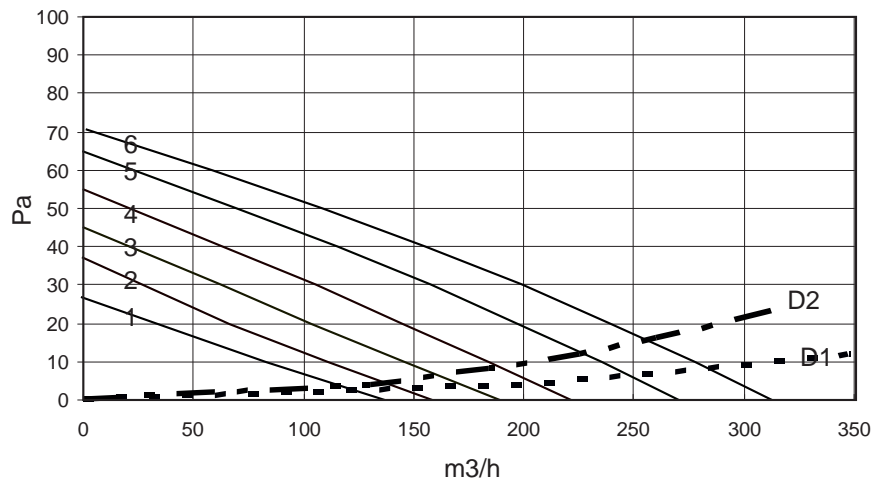

D1 = Discharge plenum only,  $\phi$ 200 mm air duct connection(s)

D2 = Discharge plenum + return plenum,  $\phi$ 200 mm air duct connections(s)



# Installation

**Figure 34 - External Static Pressure - FCD 203 with G3 filter**

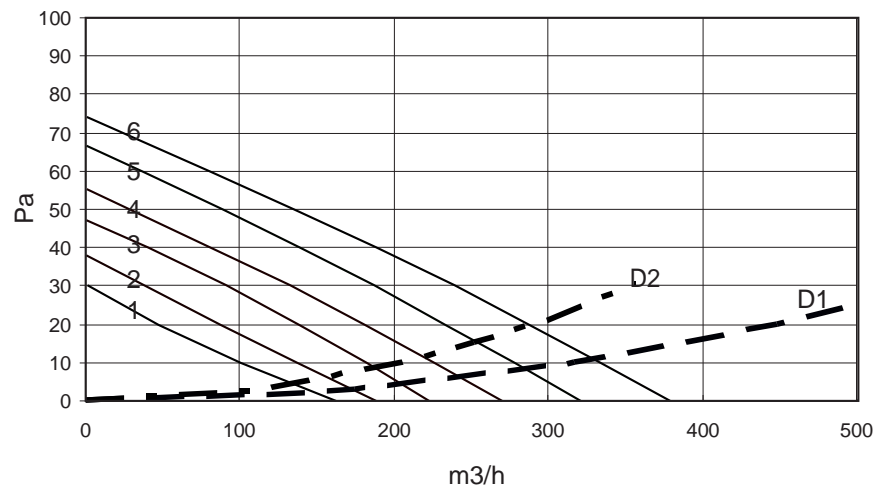

D1 = Discharge plenum only,  $\varnothing$ 200 mm air duct connection(s)  
 D2 = Discharge plenum + return plenum,  $\varnothing$ 200 mm air duct connections(s)

**Figure 35 - External Static Pressure - FCD 204 with G3 filter**

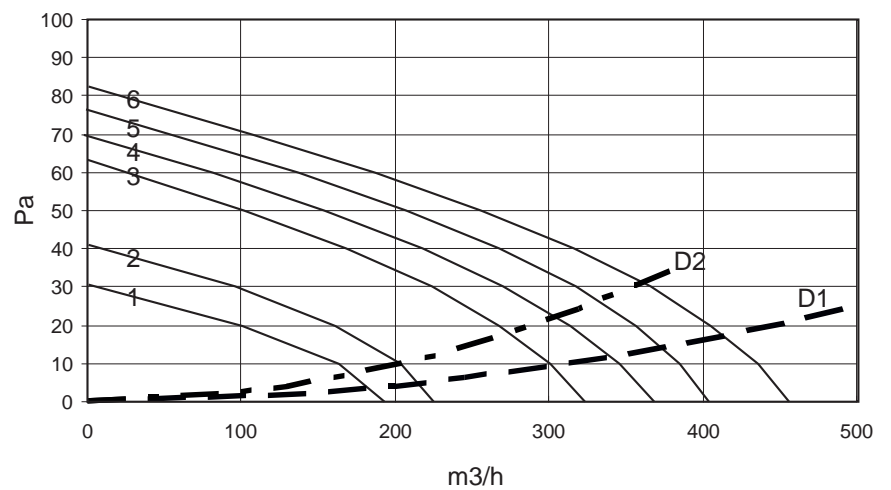

D1 = Discharge plenum only,  $\varnothing$ 200 mm air duct connection(s)  
 D2 = Discharge plenum + return plenum,  $\varnothing$ 200 mm air duct connections(s)

# Installation

**Figure 36 - External Static Pressure - FCD 304 with G3 filter**

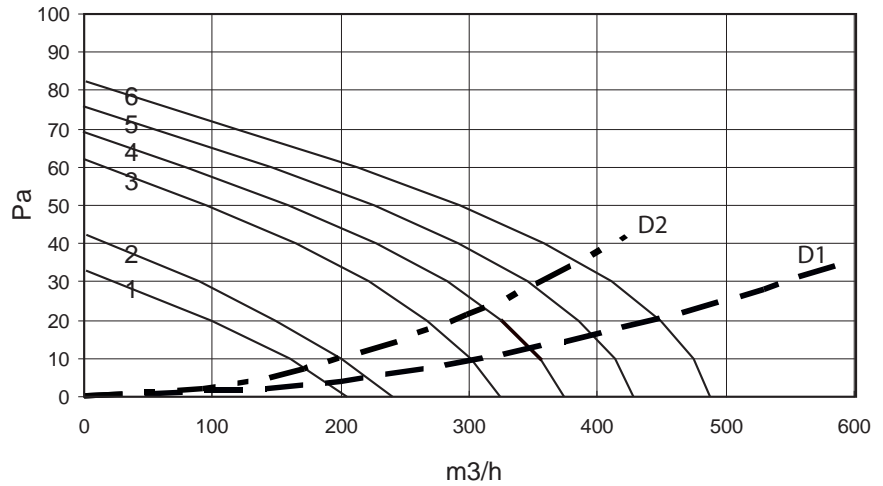

D1 = Discharge plenum only,  $\varnothing$ 200 mm air duct connection(s)  
 D2 = Discharge plenum + return plenum,  $\varnothing$ 200 mm air duct connections(s)

**Figure 37 - External Static Pressure - FCD 306 with G3 filter**

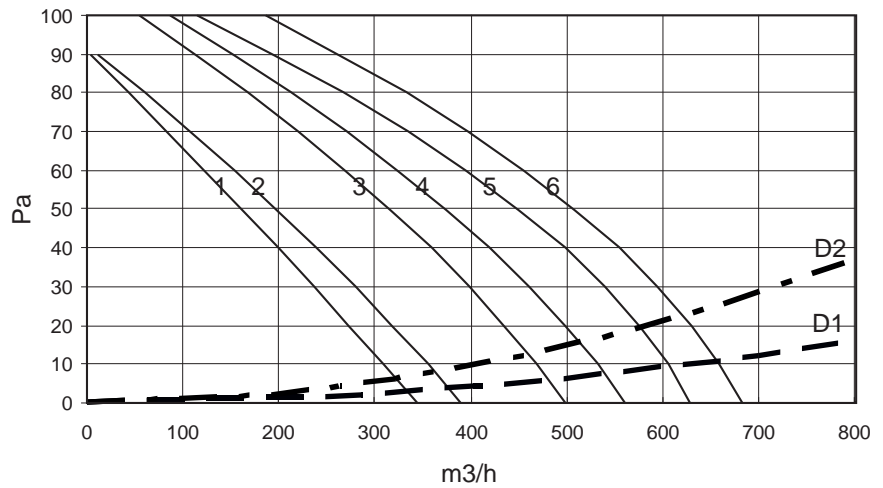

D1 = Discharge plenum only,  $\varnothing$ 200 mm air duct connection(s)  
 D2 = Discharge plenum + return plenum,  $\varnothing$ 200 mm air duct connections(s)

# Installation

**Figure 38 - External Static Pressure - FCD 406 with G3 filter**

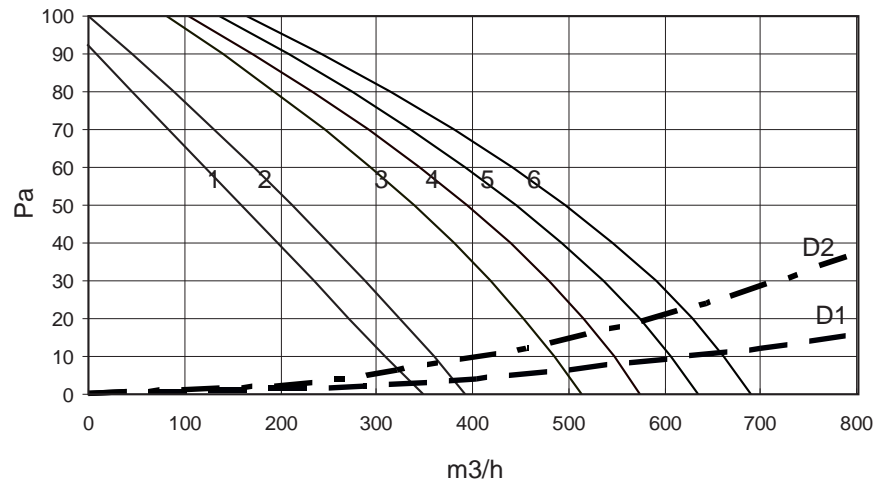

D1 = Discharge plenum only,  $\varnothing$ 200 mm air duct connection(s)  
 D2 = Discharge plenum + return plenum,  $\varnothing$ 200 mm air duct connections(s)

**Figure 39 - External Static Pressure - FCD 408 with G3 filter**

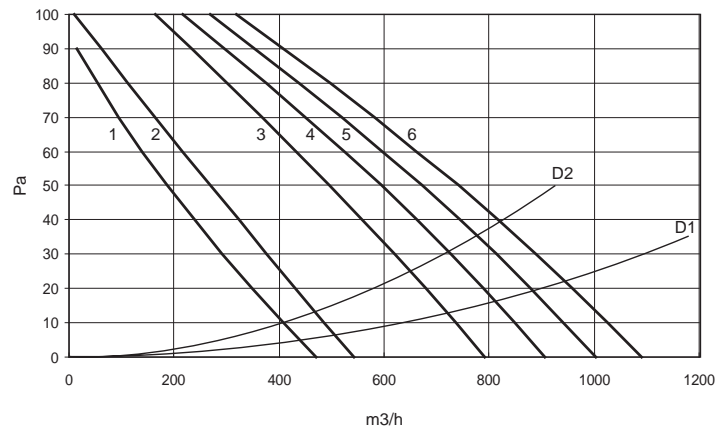

D1 = Discharge plenum only,  $\varnothing$ 200 mm air duct connection(s)  
 D2 = Discharge plenum + return plenum,  $\varnothing$ 200 mm air duct connections(s)

# Installation

**Figure 40 - External Static Pressure - FCD 508 with G3 filter**

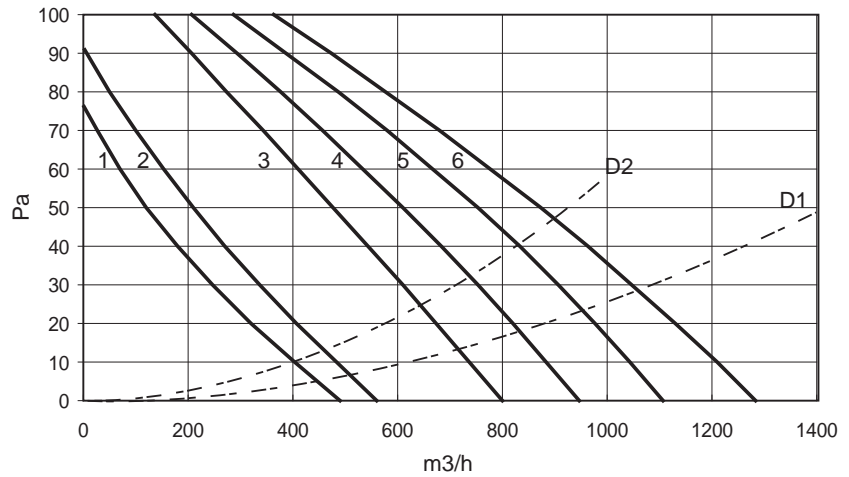

D1 = Discharge plenum only,  $\varnothing$ 200 mm air duct connection(s)  
 D2 = Discharge plenum + return plenum,  $\varnothing$ 200 mm air duct connections(s)

**Figure 41 - External Static Pressure - FCD 512 with G3 filter**

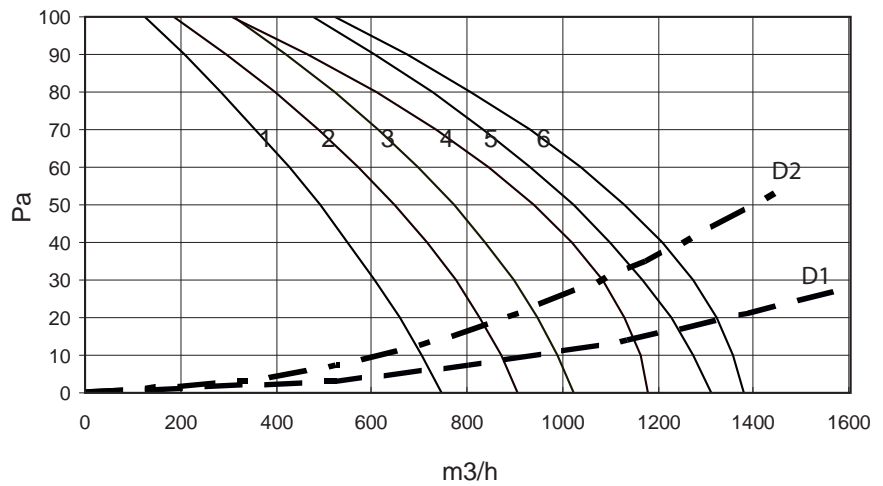

D1 = Discharge plenum only,  $\varnothing$ 200 mm air duct connection(s)  
 D2 = Discharge plenum + return plenum,  $\varnothing$ 200 mm air duct connections(s)

# Installation

**Figure 42 - External Static Pressure - FCD 612 with G3 filter**

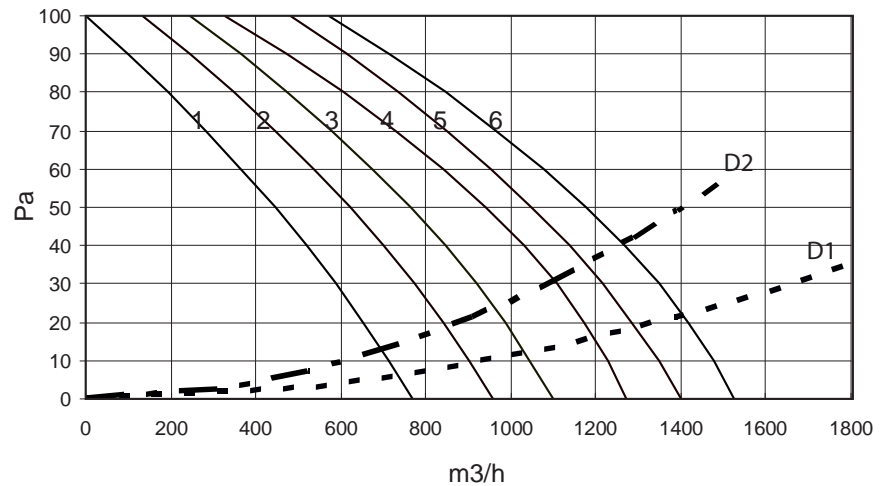

D1 = Discharge plenum only,  $\varnothing$ 200 mm air duct connection(s)  
 D2 = Discharge plenum + return plenum,  $\varnothing$ 200 mm air duct connections(s)

**Figure 43 - External Static Pressure - FCD 721 with G3 filter**

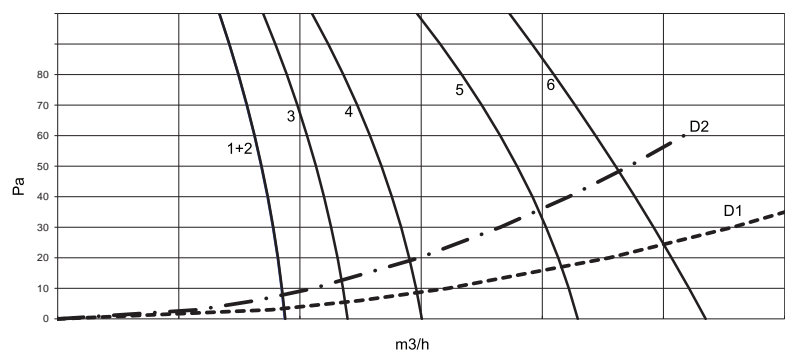

D1 = Discharge plenum only,  $\varnothing$ 200 mm air duct connection(s)  
 D2 = Discharge plenum + return plenum,  $\varnothing$ 200mm air duct connections(s)

# Installation

**Figure 44 - External Static Pressure - FED 100**

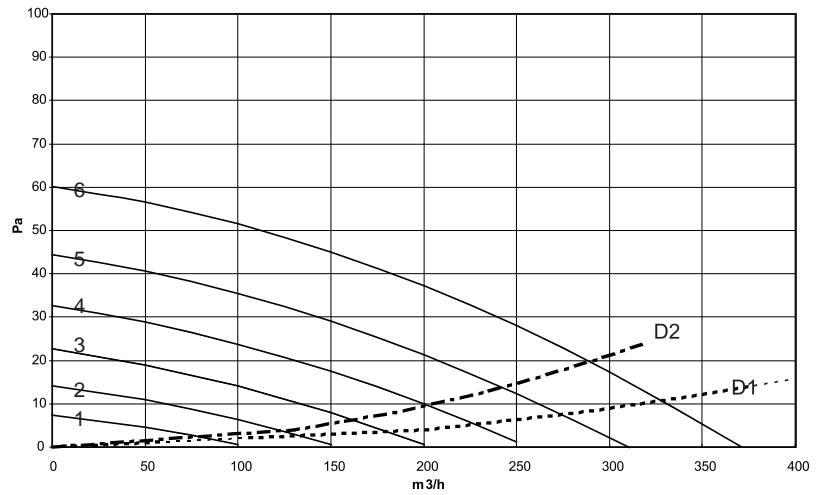

D1 = Discharge plenum only,  $\phi 200$  mm air duct connection(s)  
 D2 = Discharge plenum + return plenum,  $\phi 200$  mm air duct connections(s)

**Figure 45 - External Static Pressure - FED 200**

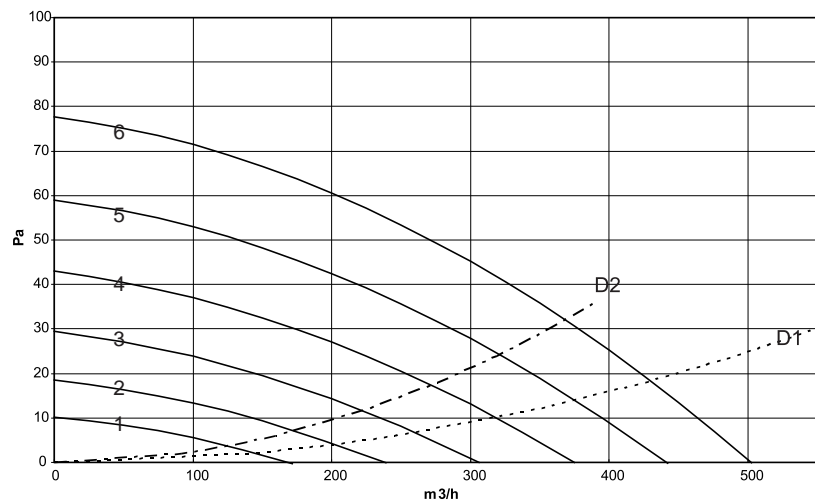

D1 = Discharge plenum only,  $\phi 200$  mm air duct connection(s)  
 D2 = Discharge plenum + return plenum,  $\phi 200$  mm air duct connections(s)

# Installation

**Figure 46 - External Static Pressure - FED 300**

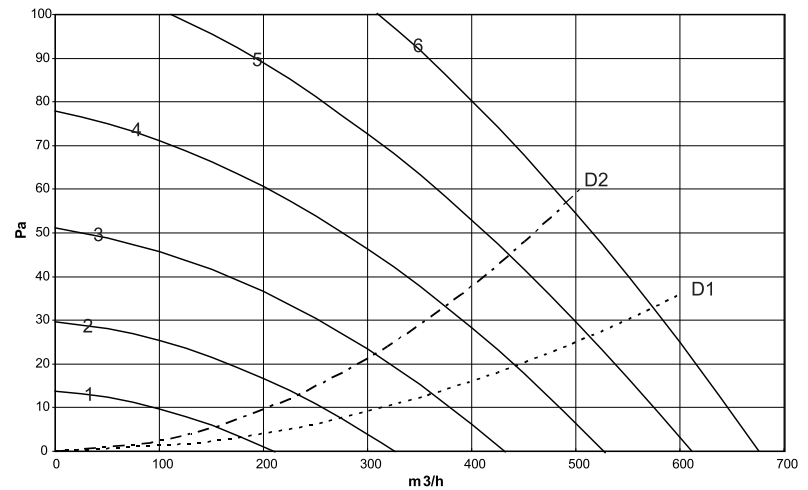

D1 = Discharge plenum only,  $\varnothing$ 200 mm air duct connection(s)  
 D2 = Discharge plenum + return plenum,  $\varnothing$ 200 mm air duct connections(s)

**Figure 47 - External Static Pressure - FED 400**

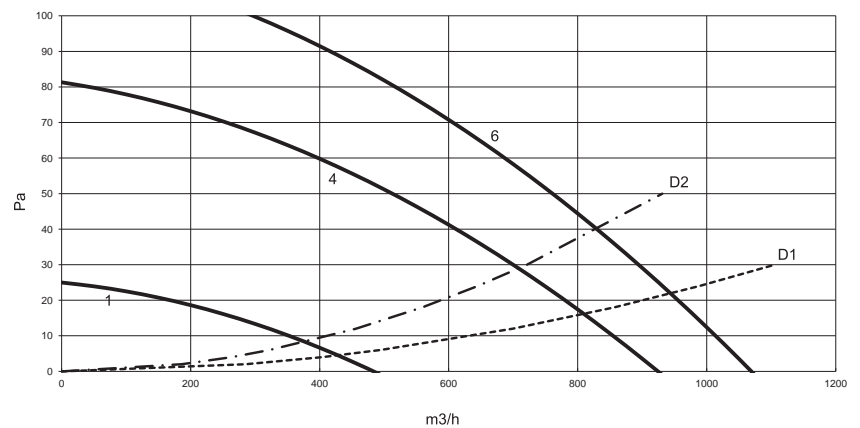

D1 = Discharge plenum only,  $\varnothing$ 200 mm air duct connection(s)  
 D2 = Discharge plenum + return plenum,  $\varnothing$ 200 mm air duct connections(s)

# Installation

**Figure 48 - External Static Pressure - FED 500**

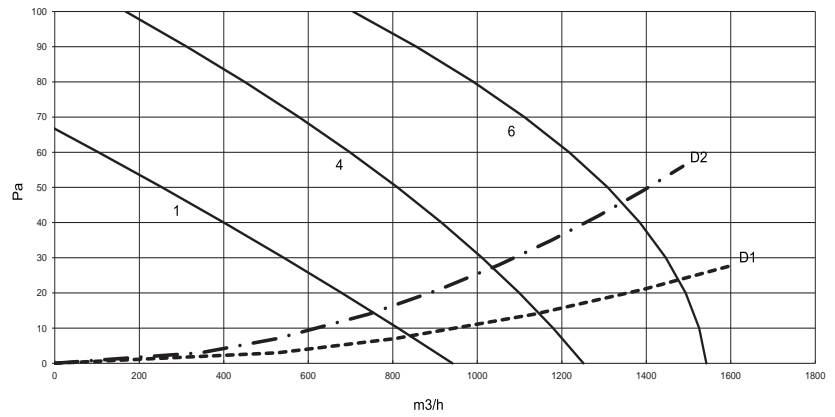

D1 = Discharge plenum only,  $\varnothing$ 200 mm air duct connection(s)  
 D2 = Discharge plenum + return plenum,  $\varnothing$ 200 mm air duct connections(s)

**Figure 49 - External Static Pressure - FED 600**

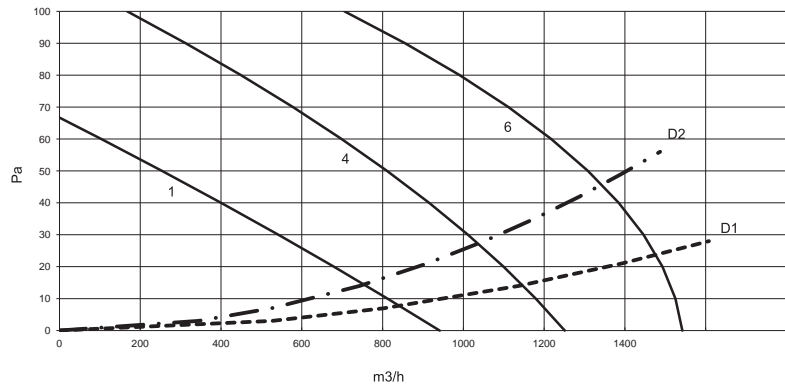

D1 = Discharge plenum only,  $\varnothing$ 200 mm air duct connection(s)  
 D2 = Discharge plenum + return plenum,  $\varnothing$ 200 mm air duct connections(s)



# Installation

## Water pressure drop curves

**Figure 50 - Water pressure drop through the coils - Cooling mode, Standard 2-pipe coil**

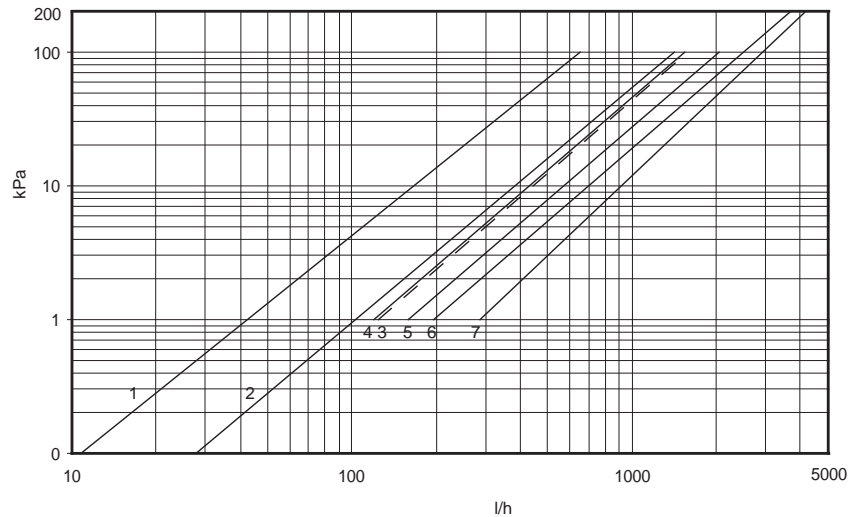

- |                                |                            |
|--------------------------------|----------------------------|
| 1 = FCD Size 101-103 / FED 100 | 5 = Size 508-512 / FED 500 |
| 2 = FCD Size 203-204 / FED 200 | 6 = Size 612 / FED 600     |
| 3 = FCD Size 304-306 / FED 300 | 7 = Size 721               |
| 4 = FCD Size 406-408 / FED 400 |                            |

**Figure 51 - Water pressure drop through the coils - Cooling mode, High capacity 2-pipe coil**

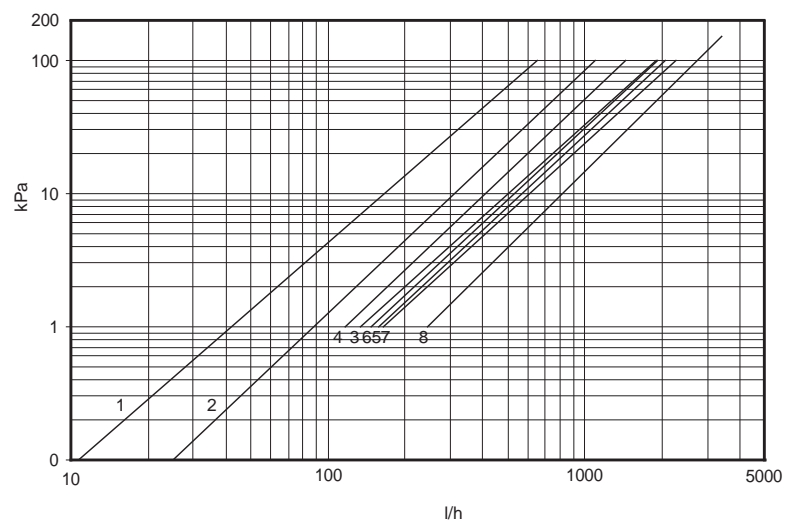

- |                                |                                |
|--------------------------------|--------------------------------|
| 1 = FCD Size 101-103 / FED 100 | 5 = FCD Size 406-408 / FED 400 |
| 2 = Size 203                   | 6 = Size 508-512 / FED 500     |
| 3 = FCD Size 204 / FED 200     | 7 = Size 612 / FED 600         |
| 4 = FCD Size 304-306 / FED 300 | 8 = Size 721                   |

# Installation

**Figure 52 - Water pressure drop through the coils - Heating mode, Standard 2-pipe coil**

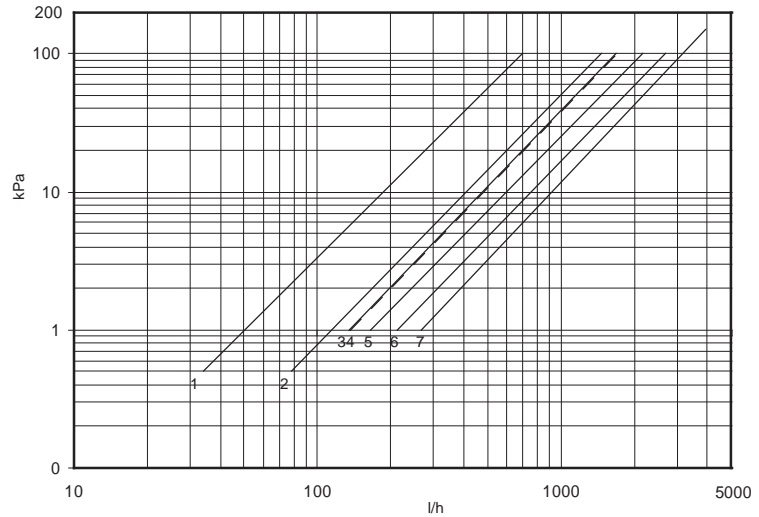

- |                                |                            |
|--------------------------------|----------------------------|
| 1 = FCD Size 101-103 / FED 100 | 5 = Size 508-512 / FED 500 |
| 2 = FCD Size 203-204 / FED 200 | 6 = Size 612 / FED 600     |
| 3 = FCD Size 304-306 / FED 300 | 7 = Size 721               |
| 4 = FCD Size 406-408 / FED 400 |                            |

**Figure 53 - Water pressure drop through the coils - Heating mode, High capacity 2-pipe coil**

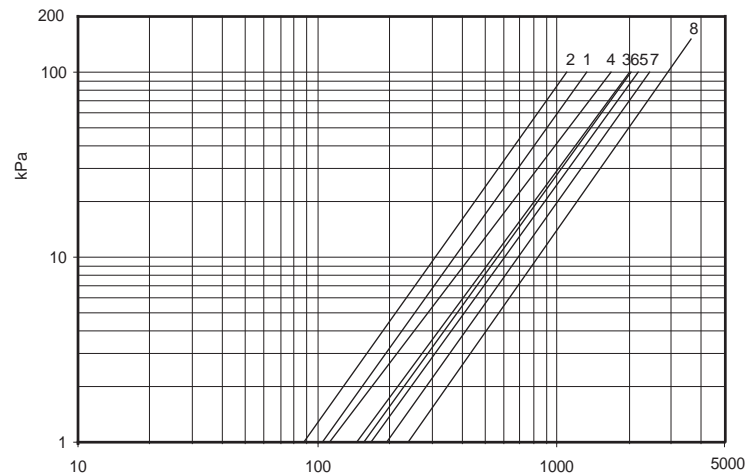

- |                                |                                |
|--------------------------------|--------------------------------|
| 1 = FCD Size 101-103 / FED 100 | 5 = FCD Size 406-408 / FED 400 |
| 2 = Size 203                   | 6 = Size 508-512 / FED 500     |
| 3 = FCD Size 204 / FED 200     | 7 = Size 612 / FED 600         |
| 4 = FCD Size 304-306 / FED 300 | 8 = Size 721                   |

# Installation

**Figure 54 - Water pressure drop through the coils - Heating mode, Standard 4-pipe coil**  
 For pressure drops of the 4-pipe coil in cooling mode, see Figure 52.

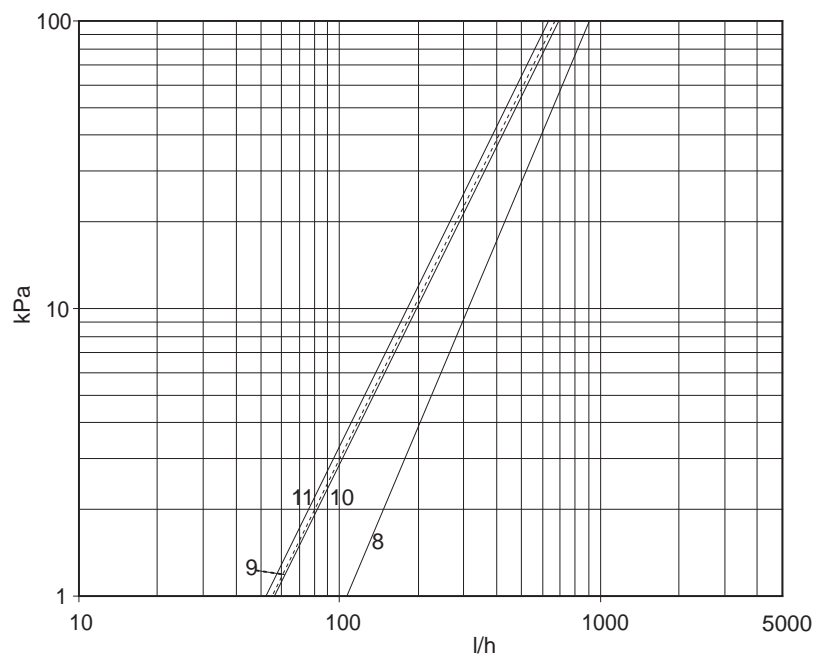
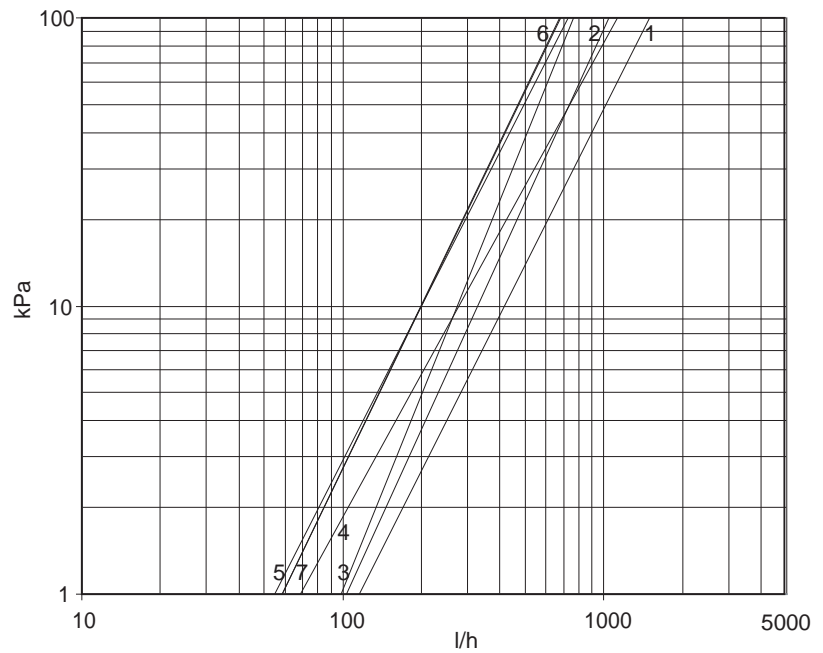

- 1 = FCD Size 101-103 Standard capacity / FED 100
- 2 = FCD Size 203-204 Standard capacity / FED 200
- 3 = FCD Size 304-306 Standard capacity / FED 300
- 4 = FCD Size 406-408 Standard capacity / FED 400
- 5 = Size 508-512 Standard capacity / FED 500
- 6 = Size 612 Standard capacity / FED 600
- 7 = Size 721 Standard capacity
- 8 = Size 203-204 High capacity
- 9 = Size 304-306 High capacity
- 10 = Size 406-408 High capacity
- 11 = Size 508-512 High capacity



# Installation

**Table 14 - Pressure drop through the valves - FCD**

Cooling / Heating - 2-pipe coil

Unit size	101/103	304/306	612/721
	203/204	406/408 508/512	
Connections (inches)	1/2	1/2	3/4
2-way on/off control Kv valve	1.6	1.6	2.5
2-way ZN 523 control Kv valve	1.0	1.6	2.5
3-way on/off control Kv valve	1.6	1.6	2.5
3-way ZN523 control Kv valve	1.0	1.6	2.5
<b>Heating (4-pipe coil)</b>			
Connections (inches)	1/2	1/2	1/2
2-way on/off control Kv valve	1.0	1.0	1.0
2-way ZN 523 control Kv valve	1.0	1.0	1.0
3-way on/off control Kv valve	1.0	1.0	1.0
3-way ZN523 control Kv valve	1.0	1.0	1.0

**Table 15 - Pressure drop through the valves - FED**

Cooling / Heating - 2-pipe coil

Unit size	100/200	300/400	500	600
Connections (inches)	1/2	1/2	1/2	3/4
2-way on/off control Kv valve	1.6	1.6	1.6	2.5
2-way ZN 525 control Kv valve	1.0	1.6	1.6	2.5
3-way on/off control Kv valve	1.6	1.6	1.6	2.5
3-way ZN525 control Kv valve	1.0	1.6	1.6	2.5
<b>Heating (4-pipe coil)</b>				
Connections (inches)	1/2	1/2	1/2	1/2
2-way on/off control Kv valve	1.0	1.0	1.0	1.0
2-way ZN 525 control Kv valve	1.0	1.0	1.0	1.0
3-way on/off control Kv valve	1.0	1.0	1.0	1.0
3-way ZN525 control Kv valve	1.0	1.0	1.0	1.0

# Installation

Figure 55- Pressure drop through the valves

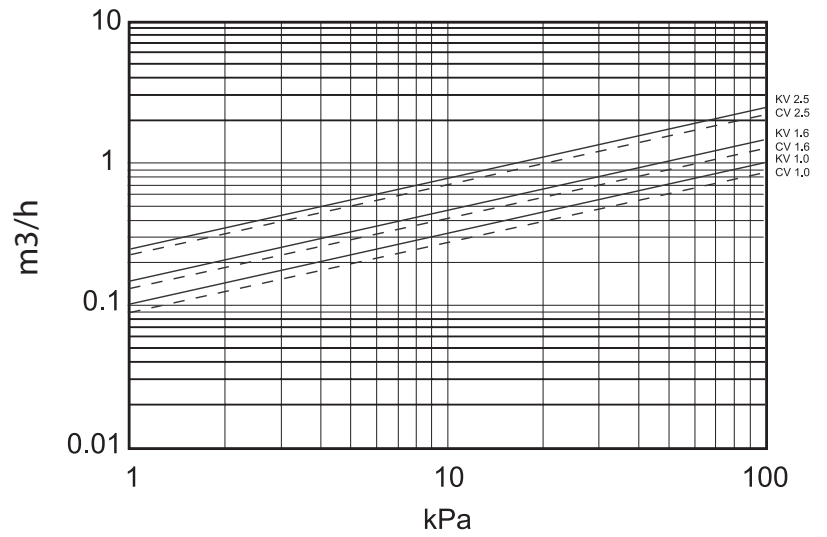



# Installation

## Pre-start checkout

1. Check the units are correctly installed and have a slight slope towards the water outlet.
2. Make sure the fan rotates freely on its shaft.
3. Check the filter is in place, if present. It is necessary to have a set of filters available because the first set will quickly become clogged due to jobsite dust.
4. Make sure all water connections (chilled water, hot water, condensate tray) are tightened correctly, leak free and insulated.
5. Make sure all electrical connections are tightened correctly.
6. Make sure the units are clean.
7. Check the condensate tray drainage pipe is connected and is not obstructed.
8. Check and clean the condensate tray and make sure the drainage line is free.

## Installation checklist

The installer should use this list to ensure that all necessary operations have been performed before startup. For more detailed information refer to the relevant paragraphs of this manual.

- The unit has been securely suspended from the ceiling in compliance with safety rules.
- Unit frame is level in both directions or has a slight slope towards the water outlet.
- Clearances are sufficient to allow maintenance.

- Condensate trays are connected.
- No dirt in the condensate tray.
- Hydraulic connections carried out, insulated, and tightened. The valve connection can be leaky until the seal inflates. After few minutes, tighten if necessary.
- Electrical connections carried out in compliance with the diagrams and local regulations.
- Filter is in place and clean.
- Anti-freeze protection of coils if necessary.
- The water loop is balanced.
- No foreign bodies in the unit.
- Adjuster and balancer bends adjusted and insulated.
- Units checked in operation (switches, thermostats, undue noise or vibration, etc.)
- Instructions given to user of the fan coil about how to operate the unit.

## Commissioning

- Check that the unit is undamaged and securely mounted
- Check the power supply
- Balance the airflow through the grilles / diffusers
- If the reading is outside the design flow, the airflow can be adjusted by means of the fan speed adjustment in the control box. (Refer to Figure 24). For a unit equipped with 200 mm diameter spigots, the recommended airflow per spigot is 290 m<sup>3</sup>/h and not exceed 450 m<sup>3</sup>/h in any case. For a unit equipped with 150 mm diameter spigots, the recommended airflow per spigot is 220 m<sup>3</sup>/h and not exceed 341 m<sup>3</sup>/h in any case.

This work should only be undertaken by a qualified electrician and the unit should be externally isolated before the control box is opened

## Initial condensate pump operational test

This operation enables to:

- check the correct installation of the system
- to bring the pump to its minimum noise level
- to make the duck valve seal

When unit is installed, follow the steps below to fill the pump in water:

1. Clean the condensate pan of any debris
2. Put water directly in the condensate drain pan
3. The pump must start to suck water and fill the clear tubing and the stop
4. Then, the pump will cycle ON and OFF until water enters the pump and come out of the pump. If not, put more water
5. Make sure that a minimum of 30 cm of water column is maintained above the pump
6. Check alarm function by continuing to put water until the alarm triggers (Stop flow rate by closing the water valve).

# Maintenance

**WARNING!** When performing any maintenance on the unit, disconnect power supply to the unit. Wear protective gloves to avoid injury.

## Servicing the electric heater

Electric heaters are protected by an automatic reset overheat thermostat and a thermal fuse protection at higher setpoint on each heating element.

Should the thermal fuse protection melt, the heating element will have to be replaced.

*Figure 56 - Electric heater*



To replace a heating element:

1. Disconnect the drain pan piping and unplug the condensate pump supply wire, if present.
2. Remove the filter and then remove the coil access panel, or panels, depending on the unit size and configuration. The panel and the drain pan are removed at the same time. The electric heater elements are visible in front of the fan outlet. The electric heater element connections are on the coil side.
3. The fan board may have to be removed. See "Servicing the fan motor assembly" section.
4. Do the operations in reverse order to reassemble.
5. **WARNING!** Be sure to install electric heater elements of the same size as the original ones.

**CAUTION !** Before replacing a heating element, check to see if the shunt was cut in the heating element that has been removed. If so, you must cut the shunt in the new heating element, as in Figure 50.

*Figure 57 - Cutting the shunt on a heating element*

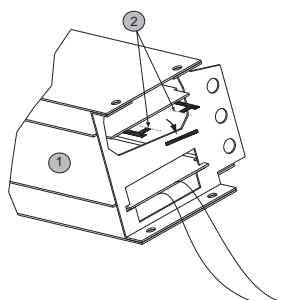

- 1 = Electric heater
- 2 = Shunt

## Accessing the filter

*Figure 58 - Handling the filter - unit without inlet air connection*

To remove the filter:

1. Slightly push the filter upwards.
2. Slightly rotate the filter.
3. Pull the filter out.

To put the filter back, hold the filter at the top of the frame with one hand. Push to clip the filter back into place at the bottom with the other hand.

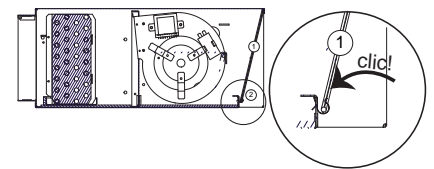

## Maintenance

---

On the unit with plenum at the inlet,

To remove the filter (1):

- 1) Unscrew the two tabs (4) and push them backwards.
- 2) Pull down the filter using a screwdriver.

To put the filter back, hold the filter at the top of the frame with one hand. Push to clip the filter back into place at the bottom with the other hand.

*Figure 59 - Handling the filter - unit with inlet air connection*





# Maintenance

## Servicing the coil

To replace or clean a water coil:

1. Disconnect the drain pan piping, the water inlet and outlet, and unplug the condensate pump supply wire, if present.
2. Remove the filter and then remove the coil access panel or panels, depending on unit size and configuration. The panel and the drain pan are removed at the same time. The coil is visible.
3. Unscrew 4 screws on the collector side and 2 screws on the opposite side (3 on Figure 60).
4. Remove the coil.

Note: If the option "Accessibility pack" has been chosen, remove one screw on the inclined coil (see Figure 61). On the straight coil, no screws need to be removed.

Figure 61 - Inclined coil

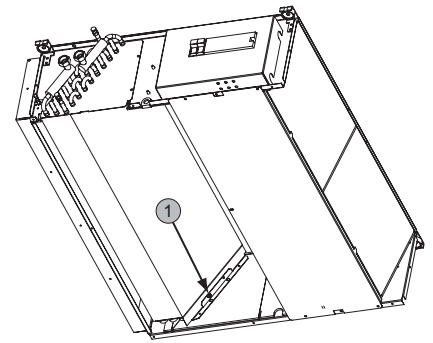

On inclined coils, unscrew one additional screw (1 on Figure 61) on the opposite side.

### Reassembly

Do the same operations in reverse order.

Figure 60 - Straight coil

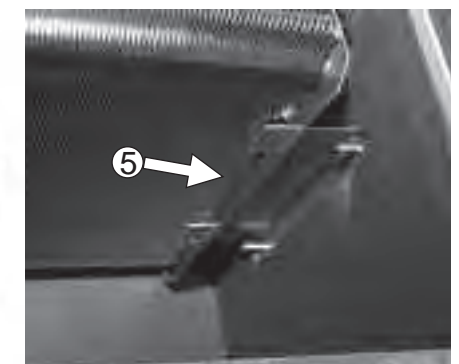
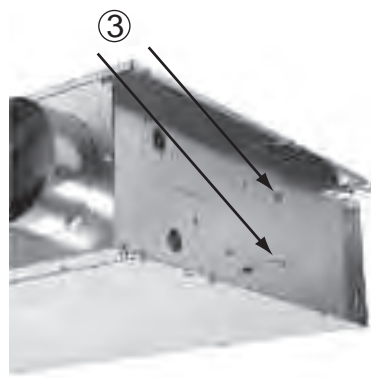
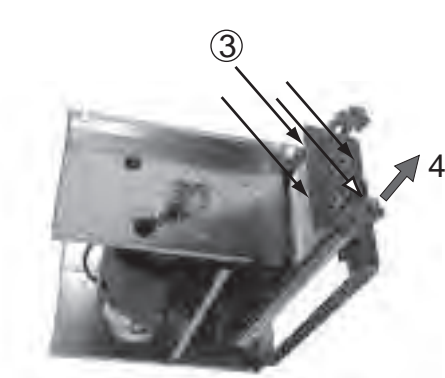

# Maintenance

## Servicing the fan motor assembly

To replace a fan board assembly:

1. Remove the filter and the fan board access panel(s), depending on unit size and configuration. The panel and the drain pan are removed at the same time. The fan board appears.
2. Disconnect the motor from the auto transformer or from the electric box (disconnects the connector and remove the snap connector of the side panel), the electric heater from the fan board and unscrew the solid-state relay. Push aside the bundle of wires.
3. Remove the 2 screws on each side panel. (4, Figure 62)
4. Remove the fan board.

Note: If the option "Accessibility pack" has been chosen:

1. Remove the two lower screws from the fan motor assembly (1, Figure 62) and unscrew (1/2 turn) the two screws at the top (2, Figure 62).
2. Push the fan motor assembly in order to remove the screw from the key hole and the fan motor assembly is released (3, Figure 62).

### Reassembly

Same operations in reverse order.

Figure 62 - Fan board assembly

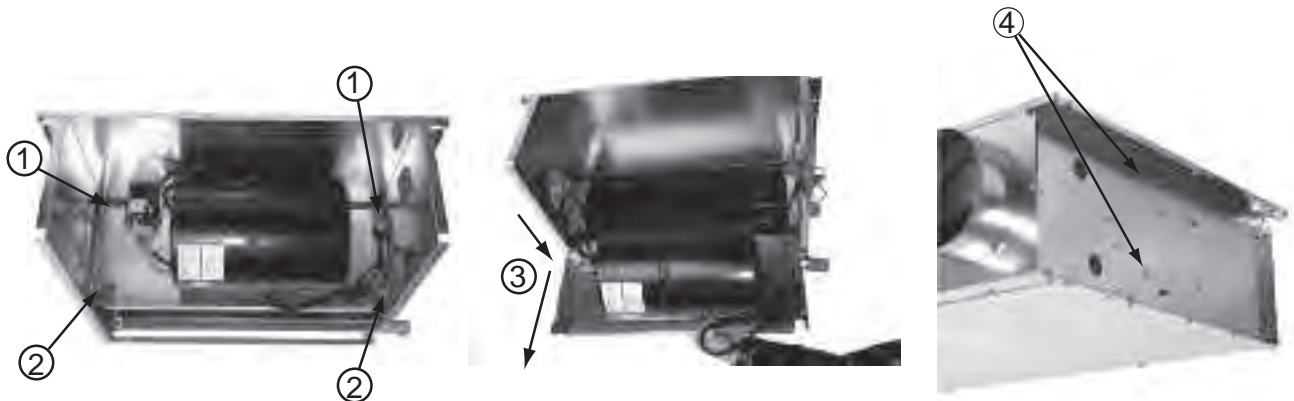

1 = 1/2 turn  
2 = Remove 2 screws

# Maintenance

---

## Periodic maintenance

It is recommended to carry out the following maintenance procedures at the stipulated frequencies to ensure the unit operates correctly.

**WARNING!** Disconnect the unit's power supply before removing the fan coil casing and servicing the unit.

## Monthly maintenance

### 1/ Filter

Inspect the filter. If necessary clean it or replace it.

Note: The first time you start up the unit, you must check the filters after one week of operation. The filters are likely to be heavily clogged because of the jobsite dust. It is recommended to procure a set of new filters. Recommendation to change it 1 to 6 times per year, depending on the environment.

### 2/ Protect against freeze-up

If the units are to be exposed to temperatures below 0°C, take the necessary precautions to avoid freeze-up of the components.

## Annual maintenance

Use random sampling of the units installed in the building (between 3 and 5%) to check:

- 1) the state of cleanliness of the condensate trays.
- 2) the condensates flow correctly (use a water spray).
- 3) the condensate pumps are operating correctly. Check the condensate pump filters by sampling and replace them if necessary.
- 4) there is no air in the coils' water circuit.

## End of hot season

To remove any impurities that have been accumulated in the unit's main tray, it is recommended to wash it with fresh water at the end of the hot season (e.g. with a water spray).

## Venting and draining the coil (if necessary)

- 1) To vent the coil, use the vent located at the top of the header (see figure 11, detail C,D and E).
- 2) To drain the coil, isolate it from the water network and use the drain located at the bottom of the header (see Figure 11, detail C,D and E).

## Motor safety

Since the motors are equipped with a thermal protection comprising automatic reset, if a prolonged shutdown occurs you must search for the cause.

# User Guide

## Thermostats type L, M, N, P, E for FCD

Thermostat type L

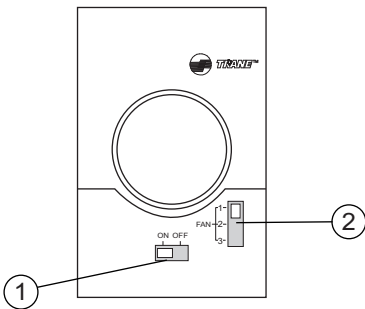

Thermostat type M and N

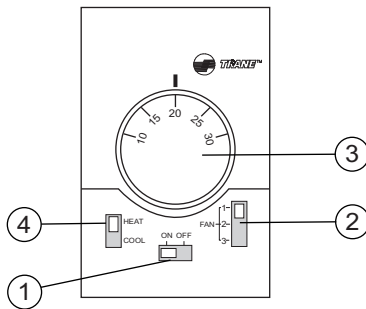

Thermostat type P

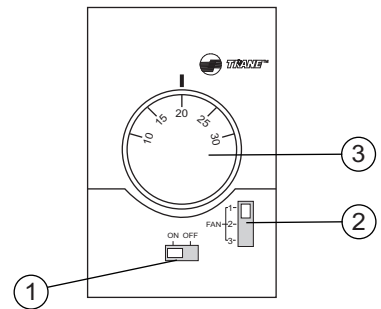

- 1 = ON/OFF selector
- 2 = Fan speed selection:
  - 1 = Low fan speed
  - 2 = Medium fan speed
  - 3 = High fan speed
- 3 = Temperature setting
- 4 = Operating mode selector:
  - Heat = Heating mode
  - Cool = Cooling mode

Thermostat type E

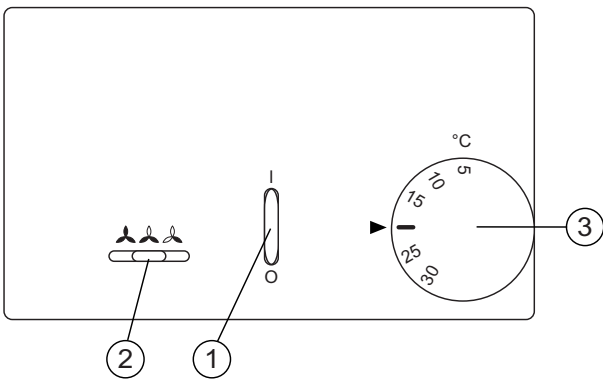

- 1 = ON/OFF selector
- 2 = Fan speed selection:

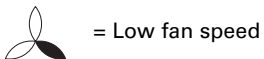

= Low fan speed

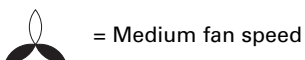

= Medium fan speed

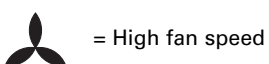

= High fan speed

- 3 = Temperature setting



## Notes

---



## Notes

---

## Notes

---



Trane optimizes the performance of homes and buildings around the world. A business of Ingersoll Rand, the leader in creating and sustaining safe, comfortable and energy efficient environments, Trane offers a broad portfolio of advanced controls and HVAC systems, comprehensive building services, and parts.

For more information, visit [www.Trane.com](http://www.Trane.com).

Trane has a policy of continuous product and product data improvement and reserves the right to change design and specifications without notice.

© 2013 Trane All rights reserved

UNT-SVX10G-E4\_0713 Supersedes UNT-SVX10G-E4\_0511

Digitally printed on environmentally friendly paper;  
produced using fewer trees and chemicals and less energy.

