



Trane Advantage

Air to water chiller and heat pumps

Rev02_08-2023

Cooling capacities R454B:

Chiller CGAF

137 – 420 kW

Sizes

042-050-052-055-060-065-070-
075-085-095-105-125

Heating capacities R454B:

Heat pump CXAF

127 – 338 kW

Sizes

042-050-055-060-061-070-074-
075-085-095



Summary

Product line-up

Product features

Working limits

Controllers

Main options

In a nutshell *(a single slide recap)*



Product line-up – R454B



Heat pump: CXAF 127 – 338 kW, SE & HE efficiency levels

CXAF R454B Performance Table			AC									EC										
V Number			2V			2.5V			3V			2V			2.5V			3V				
Size			042	050	055	060	061	070	074	075	085	095	042	050	055	060	061	070	074	075	085	095
Cooling 12/7	Net Capacity	kW	128	155	180	201	217	238	261	264	289	315	128	156	180	201	218	238	261	264	289	315
	Net Power	kW	43	51	62	73	70	77	91	83	97	111	43	50	61	72	69	77	91	83	96	110
	Net EER		2,94	3,06	2,92	2,76	3,13	3,08	2,86	3,17	2,98	2,83	2,98	3,09	2,95	2,78	3,15	3,10	2,88	3,20	3,00	2,85
	Eurovent Class		B	B	B	C	A	B	C	A	B	C	B	B	B	C	A	A	C	A	B	C
	Evap Flow	L/s	6,1	7,4	8,6	9,6	10,4	11,4	12,5	12,6	13,8	15,0	6,1	7,4	8,6	9,6	10,4	11,4	12,5	12,6	13,8	15,0
	Evap DP	kPa	19,4	28,7	25,3	31,5	15,8	18,6	22,0	22,5	26,4	22,3	19,5	28,8	25,3	31,6	15,9	18,7	22,0	22,5	26,4	22,3
	Airflow	m ³ /s	5,4	10,1	10,0	10,0	15,1	15,1	15,0	15,1	15,0	15,0	5,6	10,2	10,2	10,1	15,3	15,2	15,2	15,2	15,2	15,1
Heating 40/45	Net Capacity	kW	127	157	183	208	220	242	270	277	308	338	127	158	183	208	220	243	270	278	308	338
	Net Power	kW	41	52	60	68	68	74	85	84	94	105	41	51	59	67	67	73	84	83	94	104
	Net COP		3,09	3,04	3,08	3,06	3,26	3,28	3,19	3,32	3,27	3,23	3,11	3,08	3,11	3,08	3,29	3,31	3,21	3,35	3,30	3,25
	Eurovent Class		B	B	B	B	A	A	B	A	A	A	B	B	B	B	A	A	A	A	A	A
	Cond Flow	L/s	6,1	7,6	8,8	10,0	10,6	11,7	13,0	13,4	14,9	16,3	6,1	7,6	8,8	10,0	10,6	11,7	13,0	13,4	14,9	16,3
	Cond DP	kPa	19,4	29,4	26,3	33,7	14,3	17,0	20,7	21,8	26,5	22,6	19,4	29,5	26,4	33,7	14,3	17,0	20,7	21,8	26,5	22,7
	Airflow	m ³ /s	6,1	10,8	10,7	10,7	16,2	16,1	16,1	16,1	16,1	16,1	6,2	10,9	10,8	10,8	16,2	16,1	16,2	16,2	16,2	16,2
Heating 30/35	Net Capacity	kW	134	165	192	217	230	252	278	288	318	346	135	165	192	217	230	252	278	288	318	347
	Net Power	kW	34	43	50	57	56	62	70	69	78	86	34	43	49	56	56	61	70	69	77	86
	Net COP		3,97	3,82	3,87	3,82	4,07	4,09	3,96	4,14	4,07	4,01	4,00	3,88	3,92	3,86	4,12	4,13	4,00	4,18	4,11	4,05
	Eurovent Class		A	A	A	A	A	A	A	A	A	A	A	A	A	A	A	A	A	A	A	A
	Cond Flow	L/s	6,4	7,9	9,2	10,4	11,0	12,1	13,4	13,8	15,3	16,6	6,5	7,9	9,2	10,4	11,0	12,1	13,4	13,8	15,3	16,6
	Cond DP	kPa	21,5	32,3	28,8	36,6	15,9	18,8	22,5	23,9	28,7	24,3	21,6	32,4	28,9	36,6	15,9	18,8	22,5	23,9	28,8	24,3
	Airflow	m ³ /s	6,1	10,8	10,7	10,8	16,1	16,1	16,1	16,1	16,1	16,1	6,2	10,8	10,8	10,8	16,2	16,2	16,2	16,2	16,2	16,2
Dimensions	Length	mm	2477	2477	2477	2477	3432	3432	3432	3432	3432	3432	2477	2477	2477	2477	3432	3432	3432	3432	3432	3432
	Width	mm	2002	2002	2002	2002	2244	2244	2244	2244	2244	2244	2002	2002	2002	2002	2244	2244	2244	2244	2244	2244
	Height	mm	2408	2408	2408	2408	2537	2537	2537	2537	2537	2537	2408	2408	2408	2408	2537	2537	2537	2537	2537	2537



- 1) Working conditions: 12/7°C entering/leaving water temperature and 35°C ambient temperature, according to EN 14511-2022.
- 2) Working conditions: 40/45°C entering/leaving water temperature and DB/WB 7°C/6°C ambient temperature, according to EN 14511-2022.
- 3) Working conditions: 30/35°C entering/leaving water temperature and DB/WB 7°C/6°C ambient temperature, according to EN 14511-2022.

Product line-up – R454B



Chiller: CGAF 137 – 419 kW, SE efficiency levels

CGAF R454B Performance Table			AC											
V Number			2V								3V			
Size			042	050	052	055	060	065	070	075	085	095	105	125
Cooling (1)	Net Capacity	kW	137	156	185	198	223	236	246	266	309	337	377	419
	Net Power	kW	43,9	54,2	55,5	60,4	71,5	76,0	80,5	89,9	92,8	105,7	121,6	138,1
	Net EER		3,11	2,88	3,33	3,28	3,13	3,11	3,06	2,96	3,33	3,18	3,10	3,03
	Eurovent Class		A	C	A	A	A	A	B	B	A	A	A	B
	Water flow	m ³ /h	23,49	26,85	31,79	34,07	38,38	40,58	42,3	45,7	53,1	57,9	64,7	72,0
	Water pressure drop	kPa	40,5	52,9	31,2	35,8	45,3	33,5	36,4	42,4	29,8	34,8	42,7	37,5
Cooling (2)	P rated c	kW	137	156	185	198	223	236	246	266	309	337	377	419
	η _{s,c}	%	188%	180%	185%	186%	180%	179%	178%	177%	195%	188%	188%	186%
	SEER		4,79	4,56	4,70	4,73	4,56	4,55	4,53	4,50	4,96	4,77	4,78	4,73
High temperature process cooling (3)	P rated	kW	137	156	185	198	223	236	246	266	309	337	377	419
	SEPR HT		5,64	5,38	5,86	5,76	5,55	5,57	5,50	5,43	5,55	5,47	5,18	5,52
Dimensions	Lenght	mm	2505	2505	2505	2505	2505	2505	2505	2505	3255	3255	3255	3255
	Width	mm	1997	1997	1997	1997	1997	1997	1997	1997	2232	2232	2232	2232
	Height	mm	2412	2412	2412	2412	2412	2412	2412	2412	2531	2531	2531	2531

- 1) Outdoor temperature 35°C - chilled water temperature in/out 12/7°C. Technical data in accordance to EN 14511.
- 2) Ecodesign rating for comfort chiller - fan coil application. η_{s,c}/SEER as defined in Directive 2009/125/EC of the European Parliament and of the Council with regard to Ecodesign requirements for Comfort Chillers with 2000 kW maximum capacity - COMMISSION REGULATION (EU) N° 2016/2281 of 20 December 2016.
- 3) Ecodesign rating for comfort High temperature process refrigeration. SEPR HT as defined in Directive 2009/125/EC of the European Parliament and of the Council with regard to Ecodesign requirements for Process Chillers with 2000 kW maximum capacity - COMMISSION REGULATION (EU) N° 2016/2281 of 20 December 2016.



Product line-up – R454B



Chiller: CGAF 137 – 420 kW, HE efficiency levels

CGAF R454B Performance Table			EC											
V Number			2V							3V				
Size			042	050	052	055	060	065	070	075	085	095	105	125
Cooling (1)	Net Capacity	kW	137	157	185	199	224	237	247	266	310	337	378	420
	Net Power	kW	43,5	53,6	55,1	59,9	70,9	75,5	79,9	89,3	92,2	105,0	120,8	137,2
	Net EER		3,15	2,92	3,36	3,31	3,15	3,14	3,09	2,98	3,36	3,21	3,13	3,06
	Eurovent Class		A	B	A	A	A	A	B	B	A	A	A	B
	Water flow	m ³ /h	23,68	27,13	31,96	34,30	38,78	41,00	42,7	45,9	53,2	57,9	64,9	72,1
	Water pressure drop	kPa	53,6	70,2	40,9	47,1	60,1	44,3	48,0	55,4	29,9	34,9	42,9	37,6
Cooling (2)	P rated c	kW	137	157	185	199	224	237	247	266	310	337	378	420
	η _{s,c}	%	195%	183%	196%	198%	189%	187%	186%	184%	203%	197%	195%	191%
	SEER		4,95	4,65	4,98	5,03	4,79	4,75	4,73	4,66	5,14	4,99	4,95	4,84
High temperature process cooling (3)	P rated	kW	137,12	156,82	185,23	198,56	223,73	236,66	246,83	266,41	309,74	337,31	377,52	419,85
	SEPR HT		5,82	5,52	5,95	5,87	5,73	5,74	5,67	5,60	5,92	5,77	5,70	5,74
Dimensions	Lenght	mm	2505	2505	2505	2505	2505	2505	2505	2505	3255	3255	3255	3255
	Width	mm	1997	1997	1997	1997	1997	1997	1997	1997	2232	2232	2232	2232
	Height	mm	2412	2412	2412	2412	2412	2412	2412	2412	2531	2531	2531	2531

- 1) Outdoor temperature 35°C - chilled water temperature in/out 12/7°C. Technical data in accordance to EN 14511.
- 2) Ecodesign rating for comfort chiller - fan coil application. η_{s,c}/SEER as defined in Directive 2009/125/EC of the European Parliament and of the Council with regard to Ecodesign requirements for Comfort Chillers with 2000 kW maximum capacity - COMMISSION REGULATION (EU) N° 2016/2281 of 20 December 2016.
- 3) Ecodesign rating for comfort High temperature process refrigeration. SEPR HT as defined in Directive 2009/125/EC of the European Parliament and of the Council with regard to Ecodesign requirements for Process Chillers with 2000 kW maximum capacity - COMMISSION REGULATION (EU) N° 2016/2281 of 20 December 2016.



Product features

V number

2V

2.5V (Only for CXAF)

3V

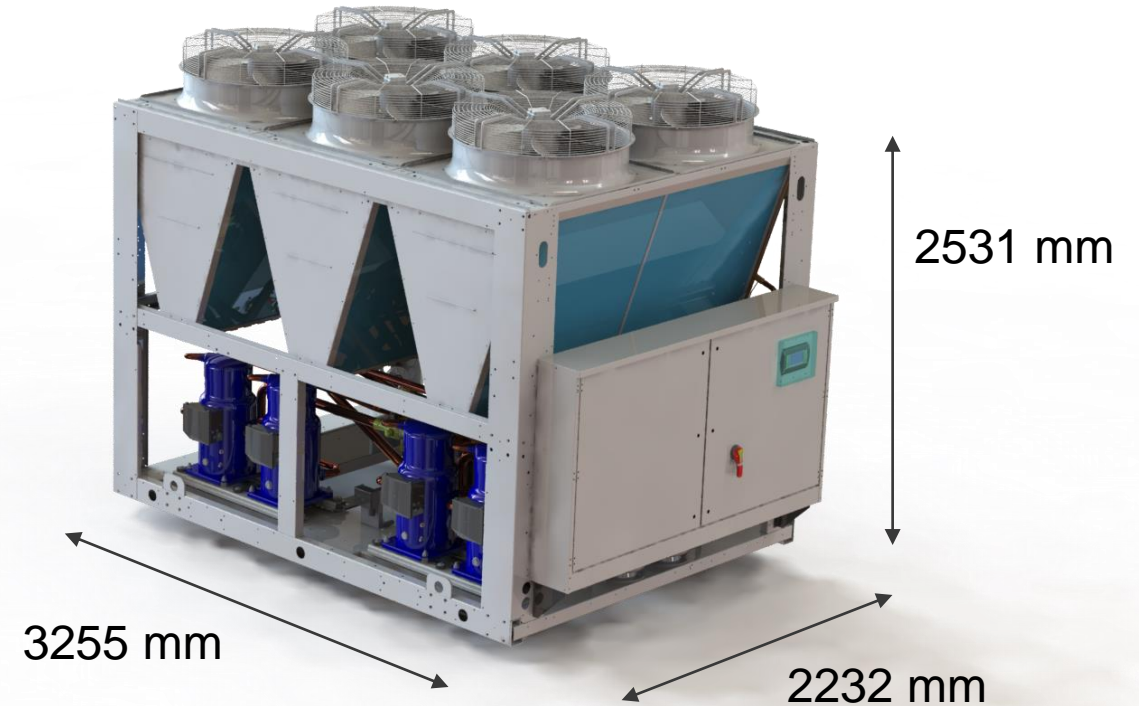
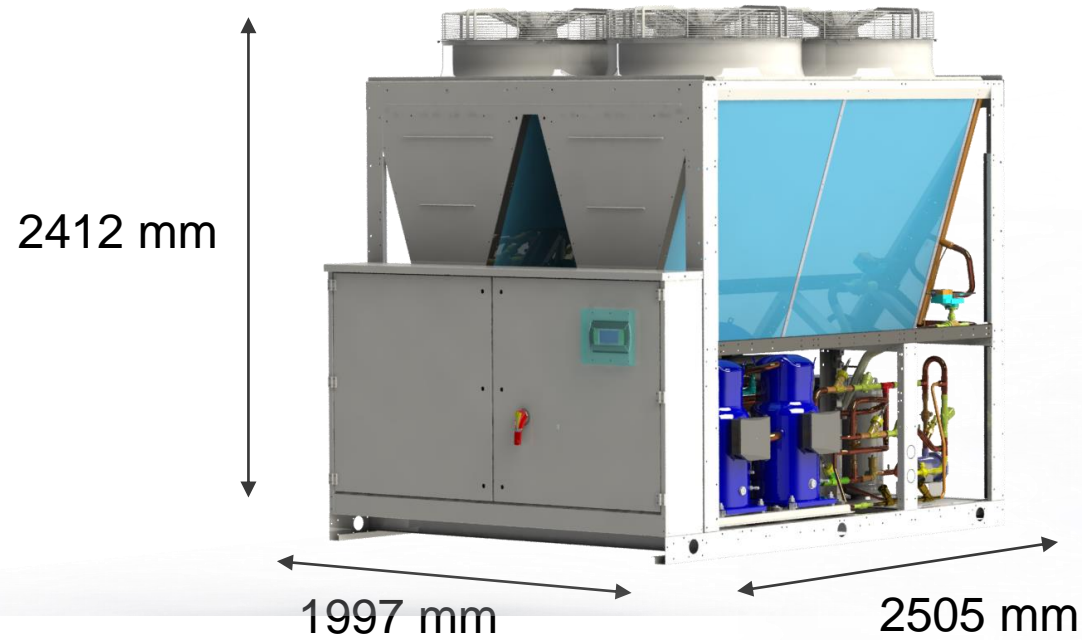

Check CAD drawings on Litweb and the selection software for deeper details



Footprint basic unit =
Footprint unit with pumps =
Footprint unit with pumps and tank

Product features

Axial fan(s):

SE units: AC fans type (3V) and AC fans + phase cut modulation for 2V and 2.5V

HE units: EC type or EC HESP

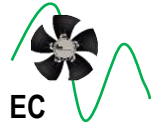
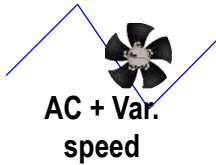

Condenser coil

- **CGAF** microchannel aluminum coil
- **CXAF** Seamless copper tubes and aluminum fins

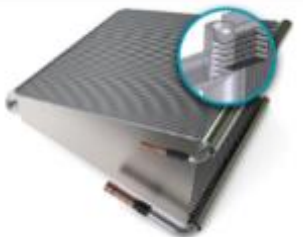

Symbio 800 controller + TD7 touch color display for all sizes



PHR (desuperheater) available as an option both for **CGAF** than **CXAF** units

Electronic expansion valve as standard



Tandem scroll compressors per each circuit

(compressor jackets optional)



Optional **hydraulic circuit** with pump and water tank with **2 possible available static pressure: standard & high!**

.... Within the same unit footprint!

Product features



- ✓ ErP2021 compliant for SEER, SEPR MT & HT (CGAF), SCOP (CXAF)
- ✓ Conto Termico compliant (CXAF)
- ✓ Very low footprint
- ✓ Hydraulic module fits in the same unit footprint
- ✓ Same Model number as per bigger CGAF, CXAF, with almost same accessories
- ✓ Electrical panel with circuit breaker.



A CXAF R454B unit in the new testing lab in Bari.

Working limits – CXAF



Only HE units with EC fans allow to go down from -10°C up to -20°C outdoor air temperature (OAT).

A certain amount of glycol may be requested according to working temperatures. Check IOM for deeper details.

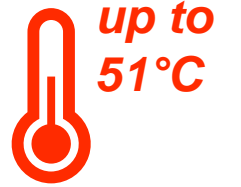
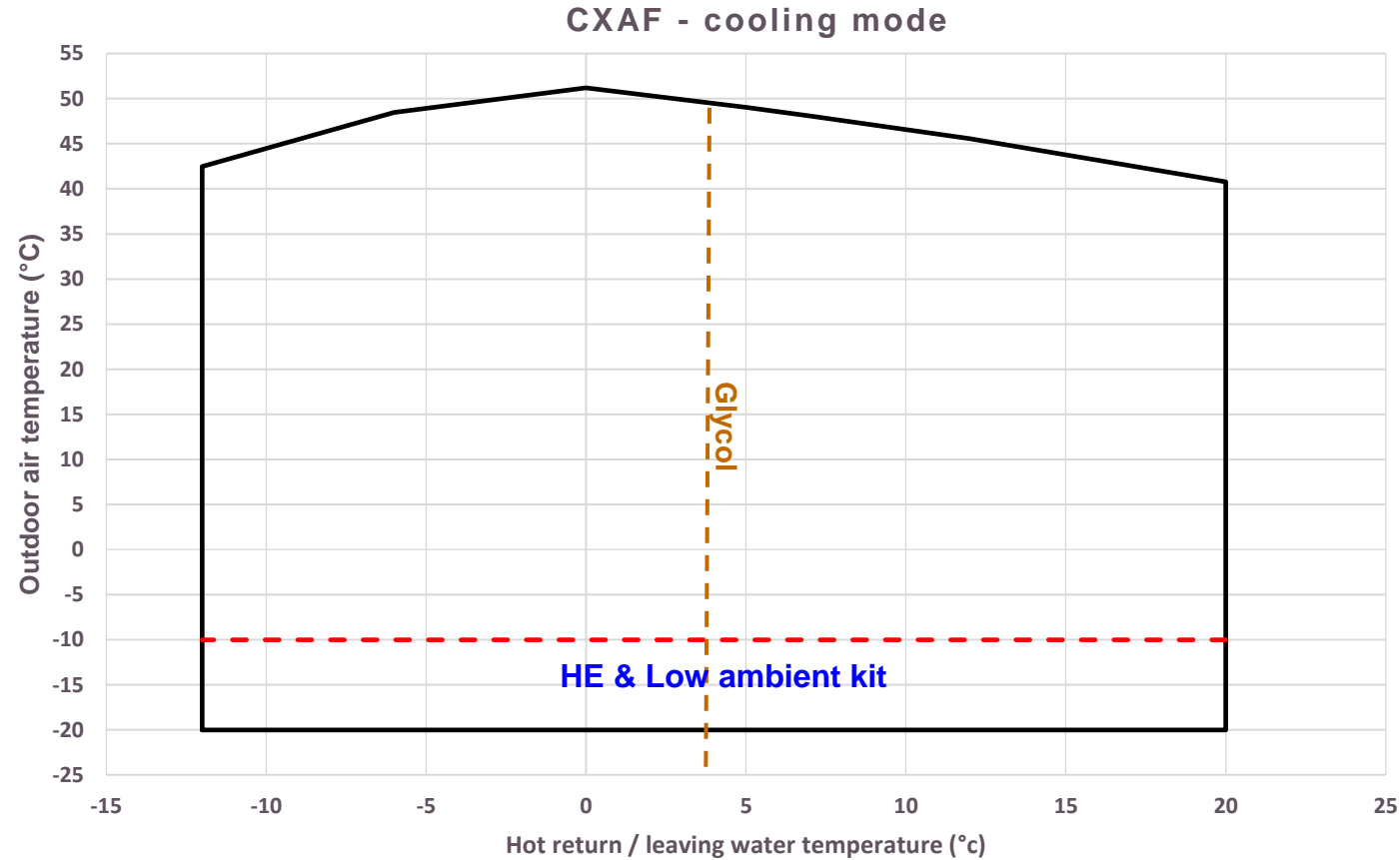

— EC Fans (High Efficiency)

- - - AC Fans (Standard Efficiency)



Down to -12°C
LWT

Working limits – CXAF



A certain amount of glycol may be requested according to working temperatures. Check IOM for deeper details.



**down to
-15°C**

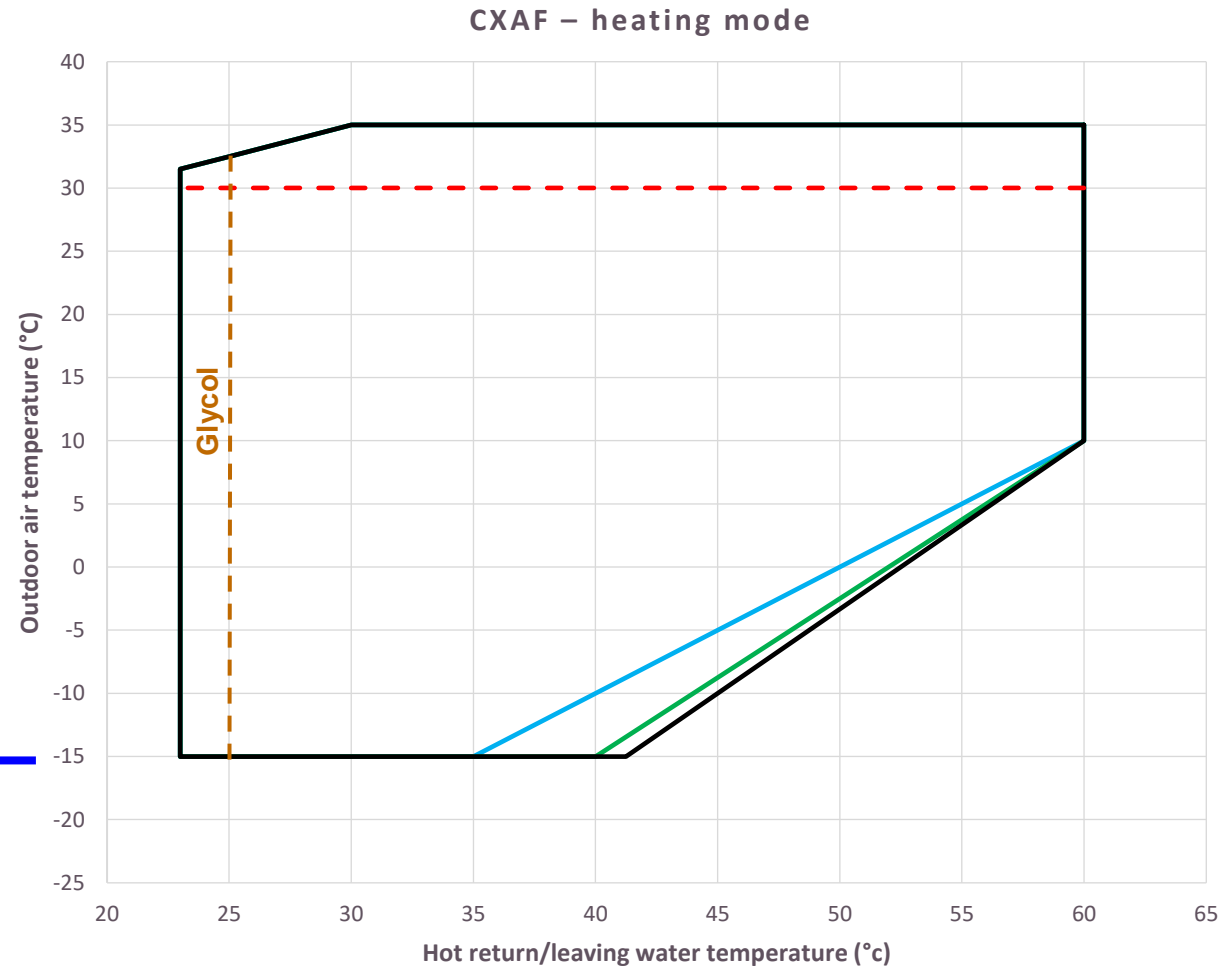

up to
60°C



— Sizes 042-050-055-060 — Sizes 061-070-074 — Sizes 075-085-095 - - - Ac fans

Working limits – CGAF



Only HE units with EC fans allow to go down from -10°C up to -20°C outdoor air temperature (OAT).

A certain amount of glycol may be requested according to working temperatures. Check IOM for deeper details.

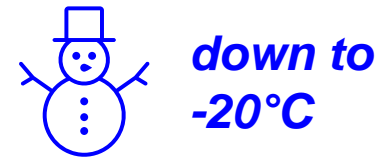
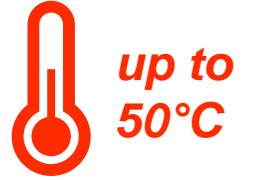
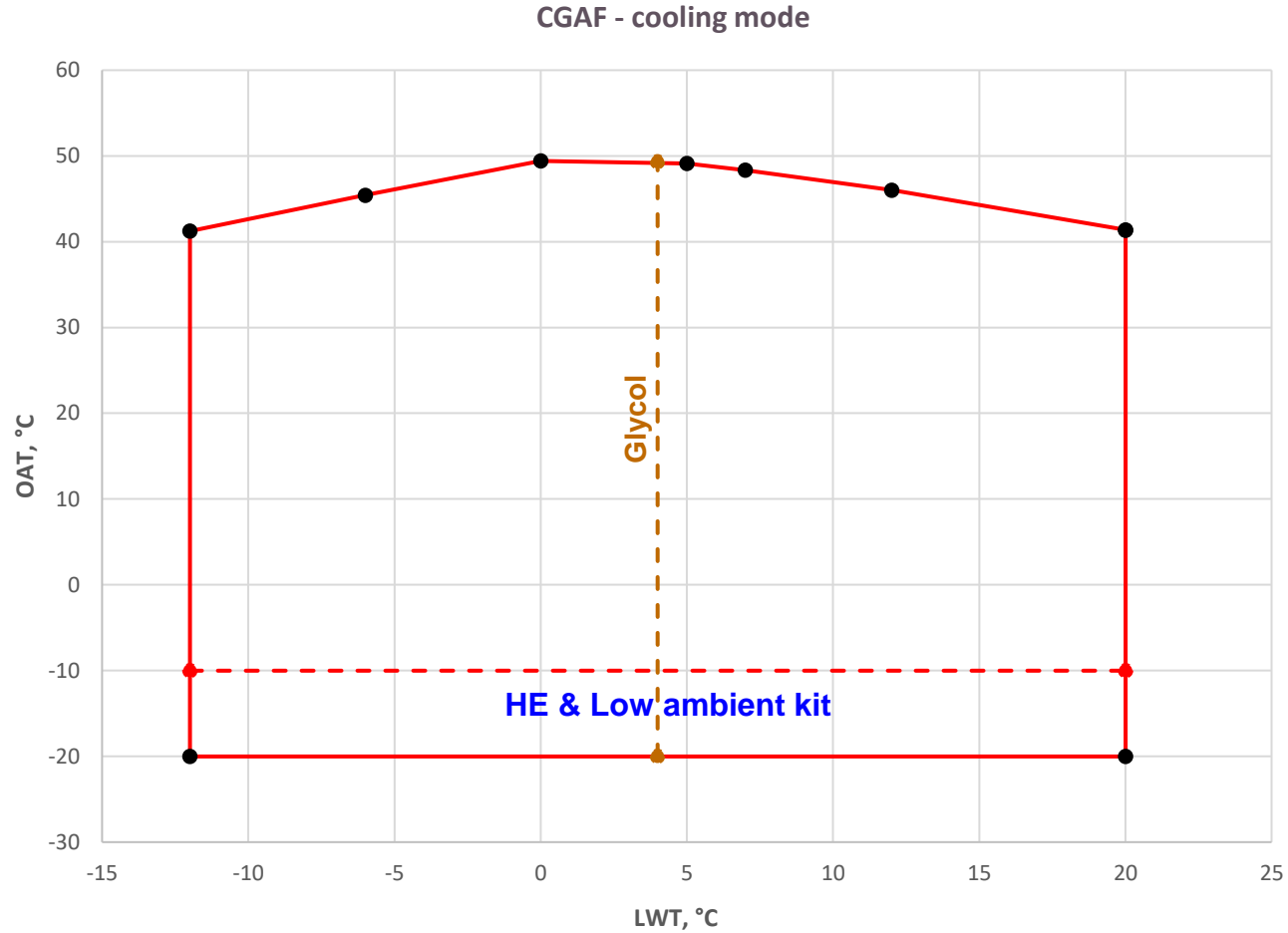

Down to **-12°C**
LWT

● CGAF HE ● CGAF SE ● Glycol

Controllers

Symbio 800 controller

- Replacing UC800 controller, well known for its legendary reliability and advanced control logic
- New functionalities added:
 - New open standard protocol support incl. BACnet IP and Modbus TCP
 - Better serviceability and access
 - Secure remote connectivity
 - Expandable I/O
 - Optional customer programming
 - Integrated Time/Day scheduling + email alarming
 - SD card backup/restore



Symbio™ 800



Service Tools



Web Based Interface



SD support

User interface TD7

- Large touch screen
- Full-color interface for simple, intuitive operation
- Main processor in the control panel



Proven, Very Reliable Unit Controller

Simple and intuitive user interface

Main options

Digit 8 = Unit voltage

Option D: As standard the power supply is 400 V, 50 Hz, 3 phase.

Option G: 400 Volt 50 Hz 3 Phase Compatible With IT Neutral.

This option is selected when the neutral point connection is requested IT. The voltage remains 400V $\pm 10\%$ / 3 phases / 50Hz

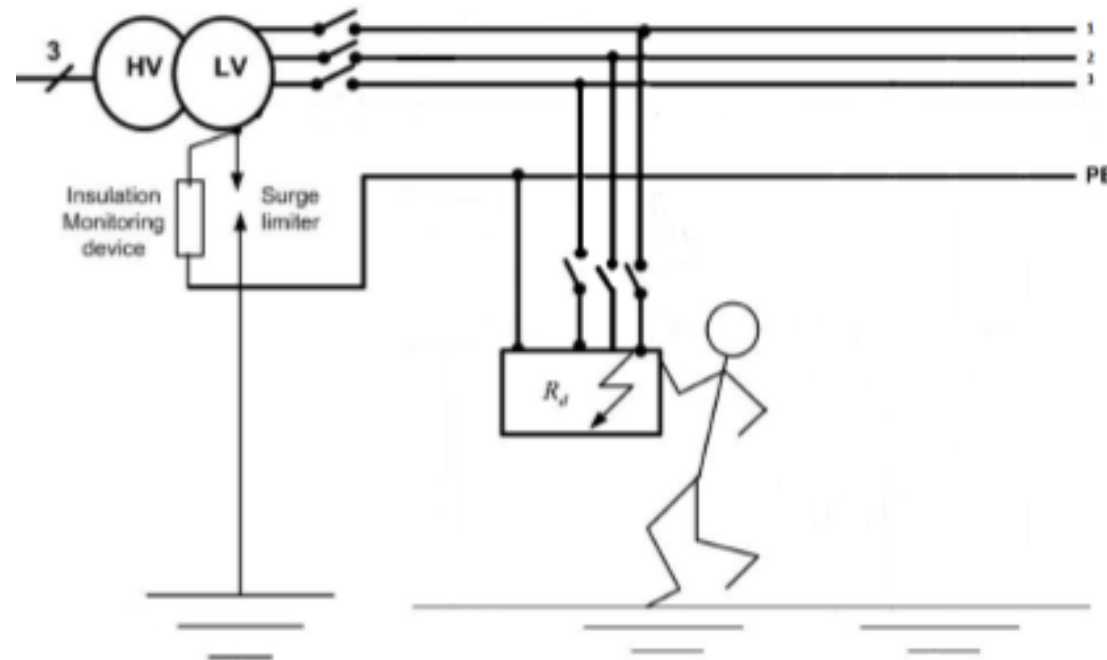

Main options

Digit 15 = L: Low noise version

Basic unit is provided with compressors jacket to reduce noise produced. This solution led to an overall noise reduction by **2 dB(A)**.

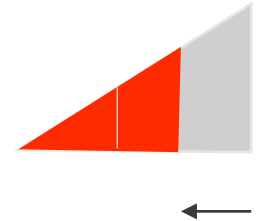
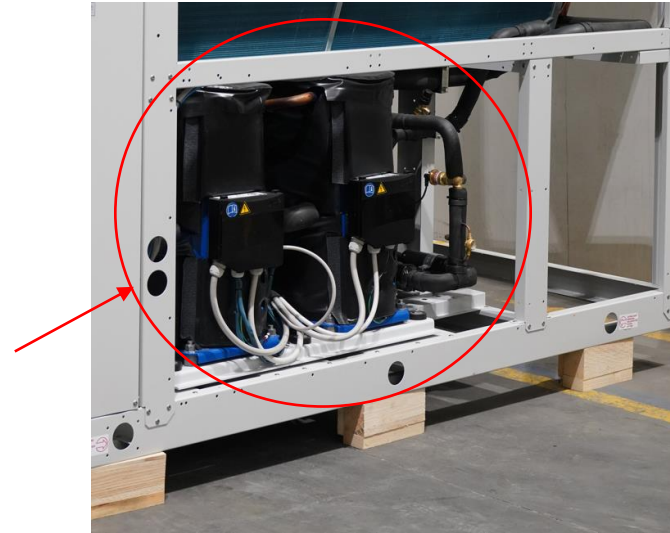

Digit 15 = E: Extra low noise version

Basic unit is provided with enhanced compressors jacket, with higher density foam. This solution led to an overall noise reduction by **3 dB(A)**.

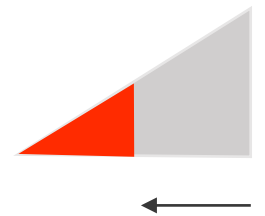
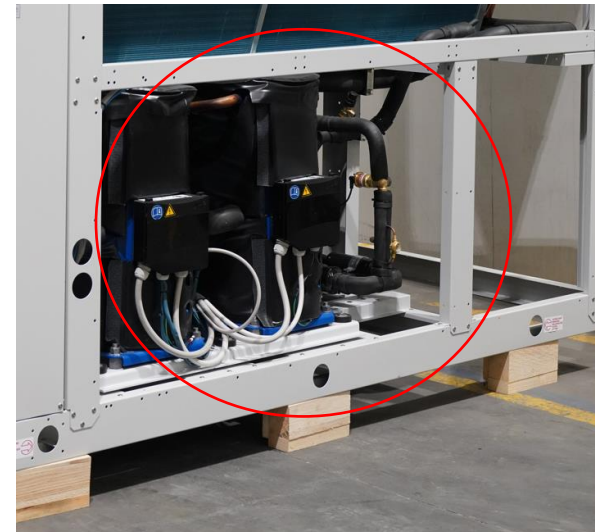

Main options

Digit 16 : Unit application

(CGAF) Digit 16 = X – Standard Ambient

The unit operates in Cooling Mode at ambient temperatures between -10°C to max °C.

Version...

→ SE

(CGAF) Digit 16 = L – Low Ambient

The unit operates in Cooling Mode at ambient temperatures between -20°C to max °C.

→ HE

(CXAF) Digit 16 = 1 – Comfort application

The unit operates in Cooling Mode at ambient temperatures between -10°C to max °C.
It operates in Heating Mode, in ambient temperatures between min °C to 30°C.

→ SE

(CXAF) Digit 16 = 3 – Process application

The unit operates in Cooling Mode at ambient temperatures between -20°C to max °C.
It operates in Heating Mode, in ambient temperatures between min °C to 35°C.

→ HE



Main options

Digit 18 : Grooved pipe with coupling

For **standard units (digit 18 = X)**, Trane supplies grooved pipe connection without Victaulic coupling. This option is used to connect the CGAF/CXAF to the water circuit.

- Connection pipes are grooved
- No Victaulic coupling on the water connection

Grooved pipe with Weld couplings (digit 18= W) :

This option is used to connect the CGAF/CXAF to the water circuit by pipe stub and couplings. It includes pipe stub and Victaulic couplings on water connection (**supplied loose**)
Used when tubes are welded.

Benefits: Victaulic piping system are safe, efficient and cost-effective, eliminating hazardous welding and lowering risk during installation.



Example of Victaulic kit

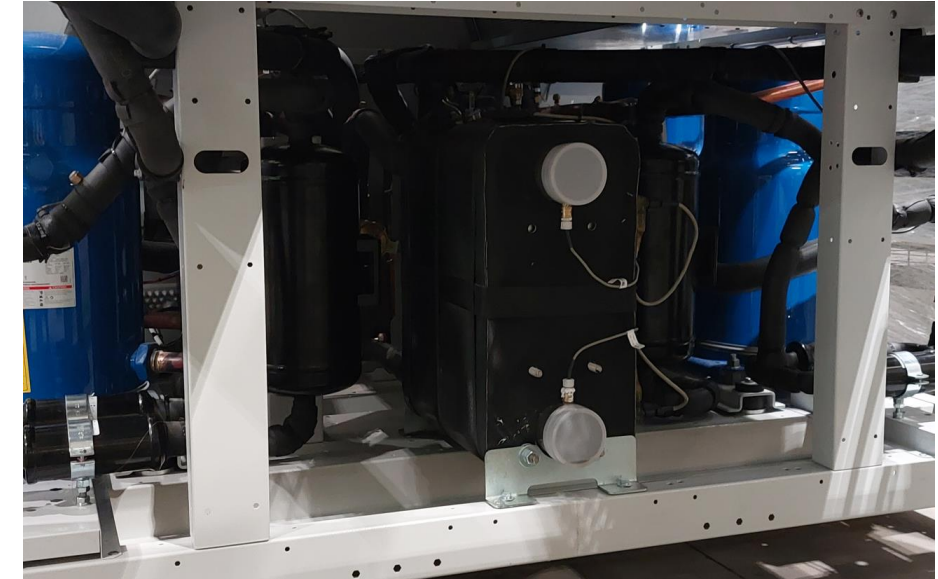

Standard unit connections: Plate heat exchanger connections are closed with a plastic cap for transport

Main options

Digit 19 : Low water temperature

Standard Cooling (digit 19= N) :

In standard the evaporator is provided with standard cooling application which the evaporator leaving temperature is in a range of **+4°C to 20°C**.

Low Water Temperature (digit 19 = P)

Unit is optimized in terms of EXV and refrigerant charge to operate **from +4°C down to -12°C** leaving water temperature.

Ice-Making (digit 19= C) :

The other option for evaporator is ice-making with a wide range of leaving water temperature between -7°C and 20°C.

The unit will run at full load until it reached the desired leaving water temperature. This option can be applied when the chiller is used to make ice at night.

The frozen water (ice) serves as thermal storage that can be melted to produce cooling. 2 set points enable the customer to control the chiller for this option: one set point used for the day time and the other one used during the night time. At night, unit generates ice when utility rates are low (off-peak period) and uses ice for cooling during the day when utility rates are high (on-peak period).



Unit without hydraulic module

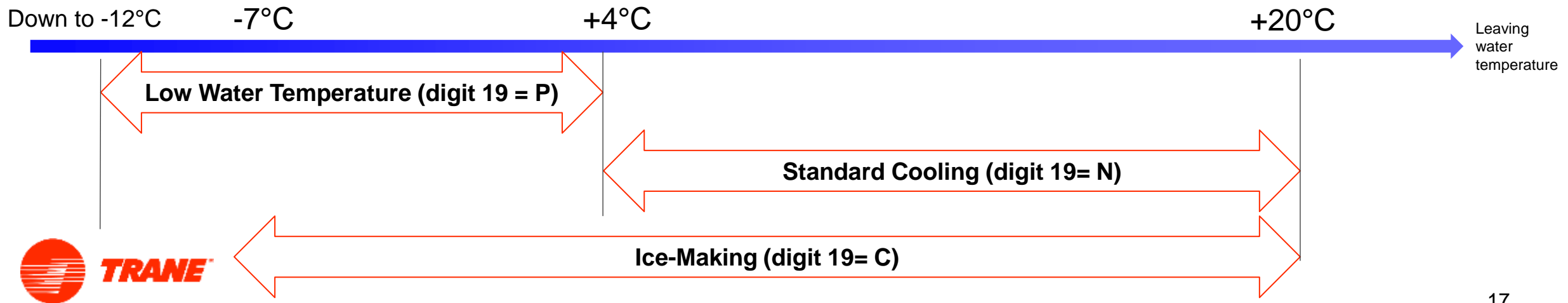

Main options

Digit 21 : Insulation

Plate heat exchanger and cold parts of the refrigerant circuit are covered by a factory-installed foam insulation, to prevent condensation on cold parts.

Insulated parts are:

- Brazed plate heat exchanger

As standard (**digit 21=N**) the insulation thickness is 10 mm, while for higher performance option (**digit 21 = H**), the insulation is 20 mm thick.

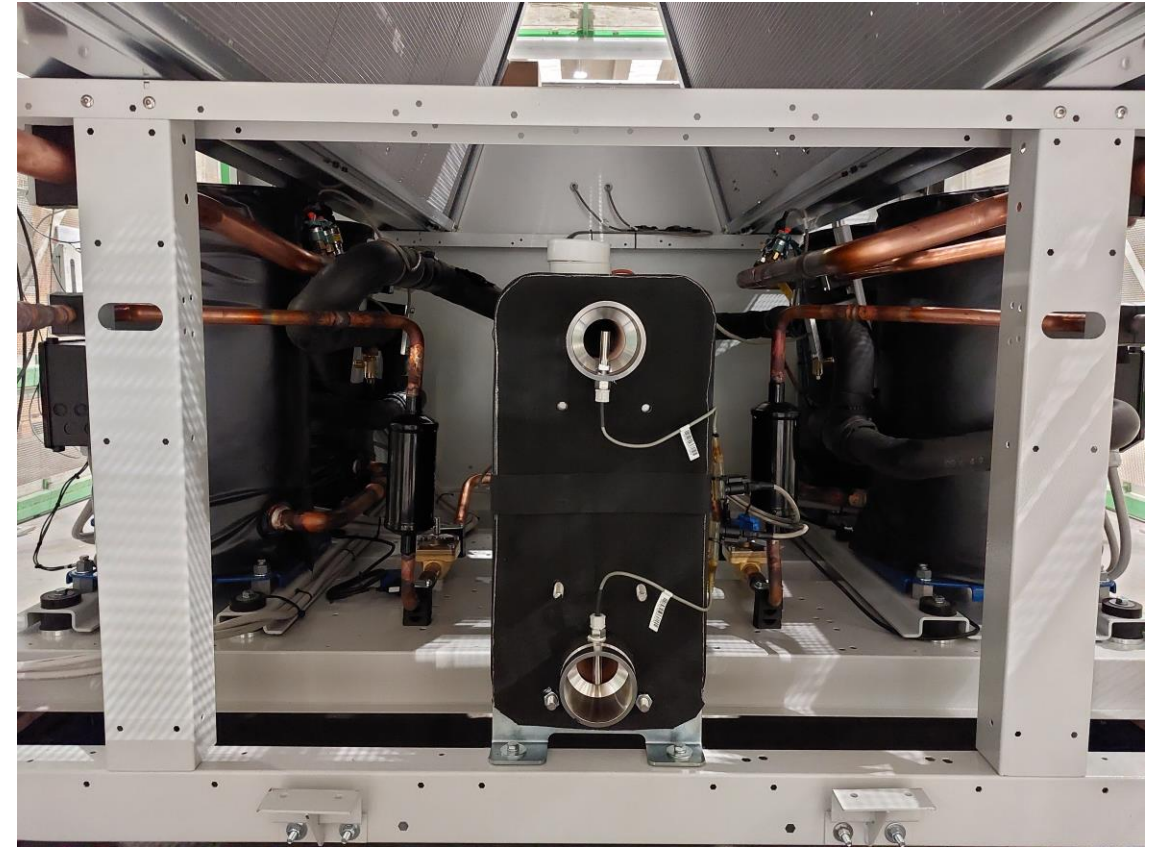

Brazed plate heat exchanger.

Main options

Digit 22 : Condenser coating

(CGAF) Micro channel (digit 22 = N) :

To use when the chiller is installed in a non-polluted area. (standard)

(CGAF) E-coated MCHE (digit 22 = C) :

An option to supply MCHE condenser coils with e-coating is available.

This e-coating withstand the exposure to typical corrosive atmospheres, in shore or industrial locations, without sensible impact on coil performances in what heat transfer and air pressure drop is a concern.



CGAF with E-coated coils

Main options

Digit 22 : Condenser coating

(CXAF) Aluminum fins (digit 22 = B) :

When the chiller is installed in **standard ambient**.

Coils are made of copper tubes and aluminum fins.

Fins are recovered with hydrophilic blue coating in order to evacuate easily water particularly during defrost.

Due to Hydrophilic treatment, water droplets easily slide off the surface of the fins to prevent ice formation.

The aluminum fins increase the capacity of heat exchange between the refrigerant and the ambient airflow.

(CXAF) Epoxy coated aluminum fins (digit 22 = E) :

Suitable for:

- When the heat pump is requested for coastal or salt mist environments.
- When the aluminum fins are exposed to hard weather conditions (acid rain, moisture, pollution, salt ...).

Fins are made out of aluminum with epoxy treatment: epoxy slows down the corrosion process on the aluminum. Epoxy layer is between 2 to 3 µm thick per surface



Blue fins



Gold epoxy aluminum fins

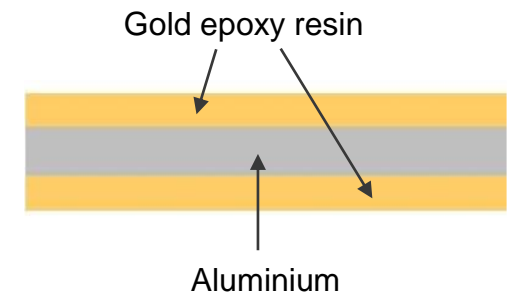

Main options

Digit 23 : Heat Recovery

Partial Heat Recovery (digit 23 = P) :

To be used when there is a need for some heating and the customer wants to save energy consumption on the heating side: pre-heating for service water for example. The chiller will allow **heat recovery by producing 20-30% of the cooling.**

Heat recovery is only possible when the chiller is ON meaning when there is a need for cooling. If there is no cooling, there is no heat recovery. Partial heat recovery is usually a complement to an existing heating system.

This option is made with two Braze Plate Heat Exchangers (BPHEs) installed on discharge lines of circuit 1 and circuit 2.

BPHE are in serial with the condenser. Water loop shall be provided by the customer.

Condenser waters temperature probes must be installed at customer care. *Probes are shipped into the electric cabinet.*

The heat exchanger benefits from the discharge gas superheat as well as a part of the condensing gas heat to be transferred to hot water system.

The Partial Heat Recovery operates without heating temperature management, nor fan speed management.

Benefits :

- Offer a “free” heating solution
- Solution integrated to the chiller

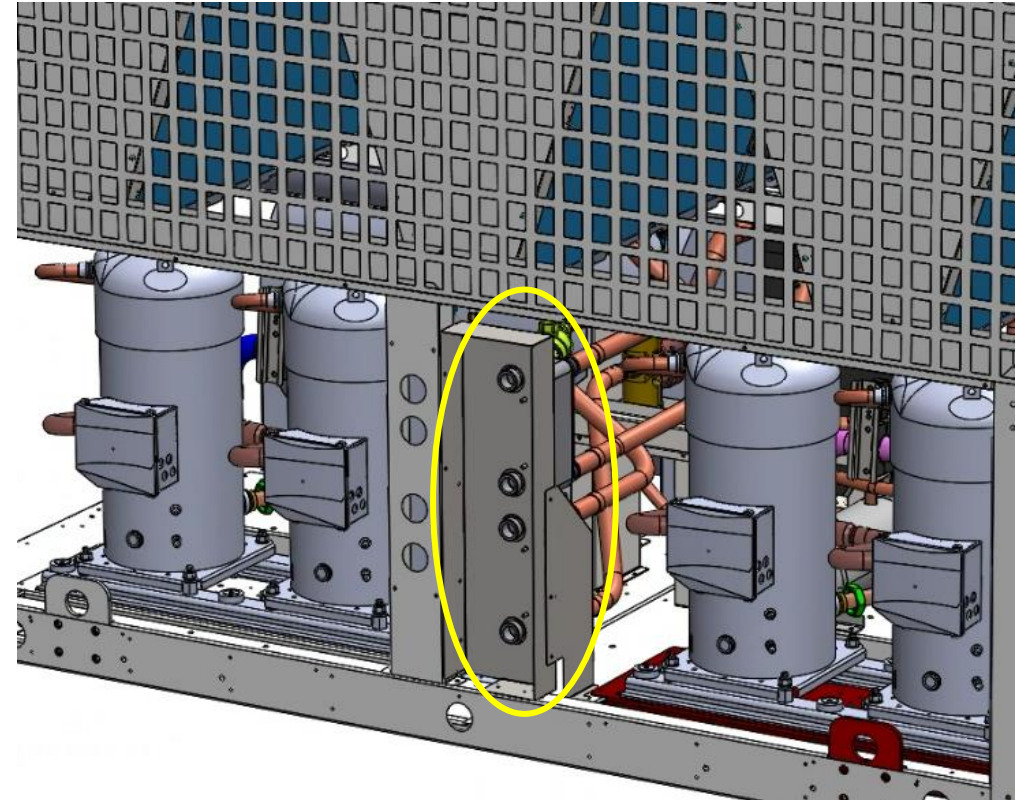

Water connection for PHR heat exchangers (one per circuit)

Main options

Digit 23 : Heat Recovery available from January 2024

Total Heat Recovery (digit 23 = T) :

To be used when there is a need for a fair amount of heating and the customer wants to save energy consumption on the heating side. The chiller is equipped with an additional heat exchanger to reclaim waste heat from the refrigeration cycle, producing 50-85% of heating capacity in relation to the cooling load.

Heat recovery is only possible when the chiller is on, meaning when there is a need for cooling. With no cooling, there is no heat recovery.

A Brazed plate heat Exchanger is installed on discharge lines of circuit 1 and circuit 2, in serial to the condenser. A 3-way-valve and 2 temperature sensors are installed on the water loop. 2 additional temperature sensors are installed on discharge lines, for internal control purposes.

Total heat recovery option:

- One BPHE, installed on discharge line, in series with the air-cooled condenser, for both refrigerant circuits
- 3-way valve and 2 water temperature sensors
- Freeze protection heater for ambient air temperatures down to 4°C (Digit 49=2)
- Heat recovery mode is activated, via dry contact, by the customer

Benefits

- Offer a “free” heating solution
- Solution integrated to the chiller

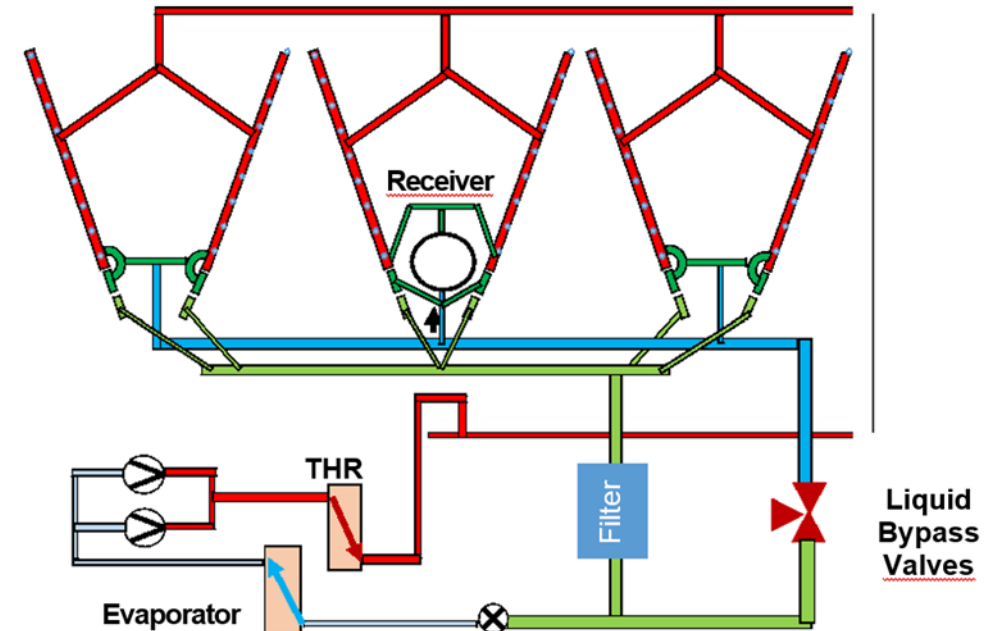

Main options

Digit 24 : Hydraulic pump(s)

Possible combinations for leaving water temperature down to -5°C

- Dual pump standard pressure (digit 24 =1)
- Single pump standard pressure (digit 24 =2)
- Dual pump high pressure (digit 24 =3)
- Single pump high pressure (digit 24 =4)

Pump model list is available in Litweb.

Selection is possible using mobile TOPSS application (TSA)

Possible combinations for leaving water temperature below -5°C down to -12°C

To overcome higher density fluid density, **pumps are fitted with enhanced motors** compared to the previous ones.

Pump curves are the same as in options 1,2,3,4

- Dual pump standard pressure with LWT < -5°C (digit 24 =A)
- Single pump standard pressure with LWT < -5°C (digit 24 =B)
- Dual pump high pressure with LWT < -5°C (digit 24 =C)
- Single pump high pressure with LWT < -5°C (digit 24 =D)

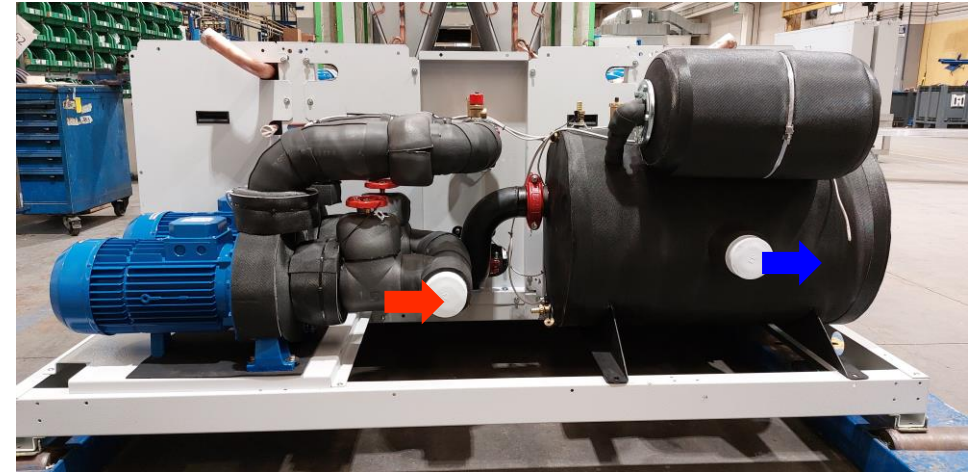

Double pumps unit with tank (digit 50)

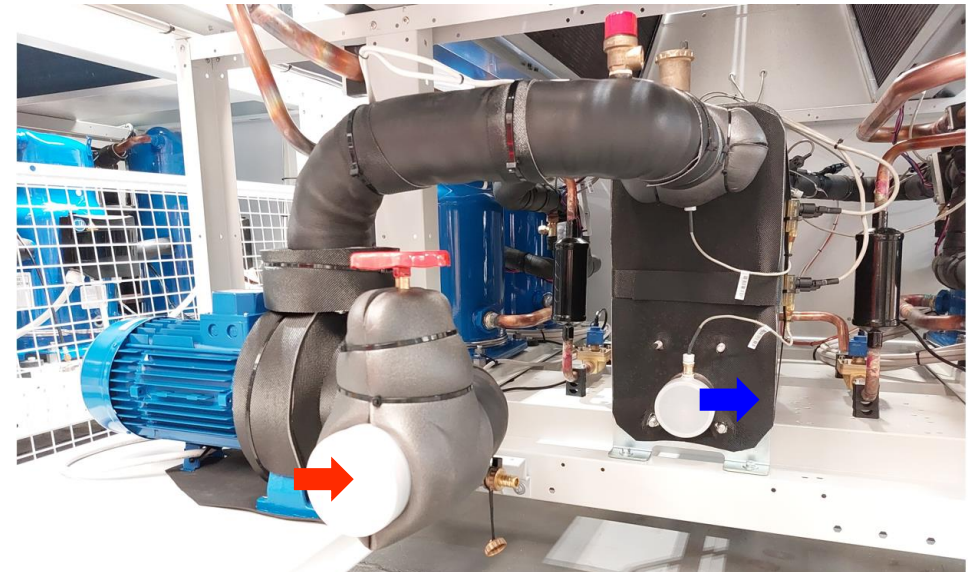

Single pump unit

Main options

Digit 26 : Disconnect switch (standard)

it's main switch to power on and off the unit
List of the main switches used is reported in the unit IOM

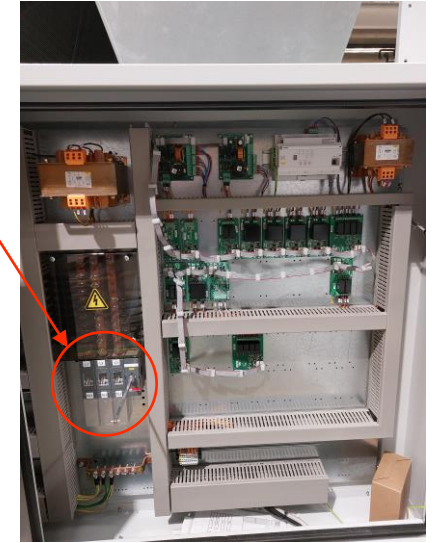

Digit 27 : Under/Over Voltage Protection

Under/Over Voltage Protection (digit 27= 1)

The unit is designed to be powered with 400V +/- 10%. In case of voltages out of tolerance, the motor lifetime will reduce dramatically with the increase or decrease of voltage. This option is used to protect the unit against under/over voltage. **It controls also the phase reversal.**

The unit is protected against network voltage variation that could reduce the lifetime of the motors when exceeding the given values.

Under/Over Voltage Protection and ground fault protection (digit 27=2)

IN addition to digit 27=1, The unit has the ground protection, to protect the electrical distribution system from ground faults.



Main options

Digit 29 : Remote interface

The Building Automation and Control Network protocol is a standard that allows building automation systems or components from different manufacturers to share information and control functions.

CGAF and CXAF controller, Symbio 800 is factory-mounted and located in the control panel box.

Different remote interfaces are available:

- BACnet interface RS485 (MSTP) (digit 29 = B) :
- BACnet interface TCP-IP (digit 29 = C) :
- ModBus interface RS485 (RTU) (digit 29 = M) :
- ModBus interface TCP (digit 29 = T) :
- LonTalk interface (digit 29 = L) LonTalk communication is made with an U60 interface.

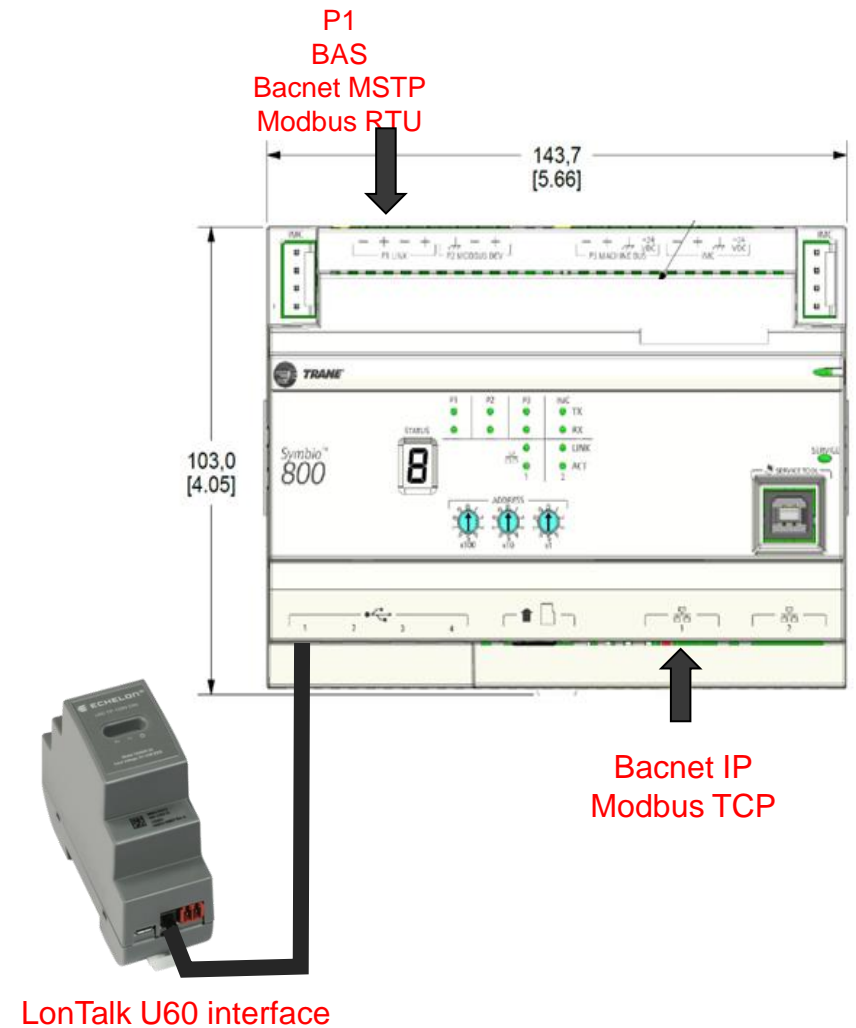

Main options

Digit 30 : External Set points & Capacity outputs

When to use it?

1. (EXTERNAL SET POINT) When the chilled water set point needs to be set by sending an external signal (E3)
2. (DEMAND LIMIT) When the number of compressors allowed to start needs to be limited in order to control chiller power consumption by sending an external signal (E4)

How is made?

- There is one input to set the Chilled Water set point and one input according to the limit set point
- Symbio 800 accepts dual analog input suitable for customer connection to set the unit external chilled water set point (ECWS) and the external demand limit set point (EDLS).

Which are the Benefits ?

- Energy savings.
- Provides the possibility to set the chilled water and the demand limit set point from an external signal from remote location.
- Adaptation to customer power supply

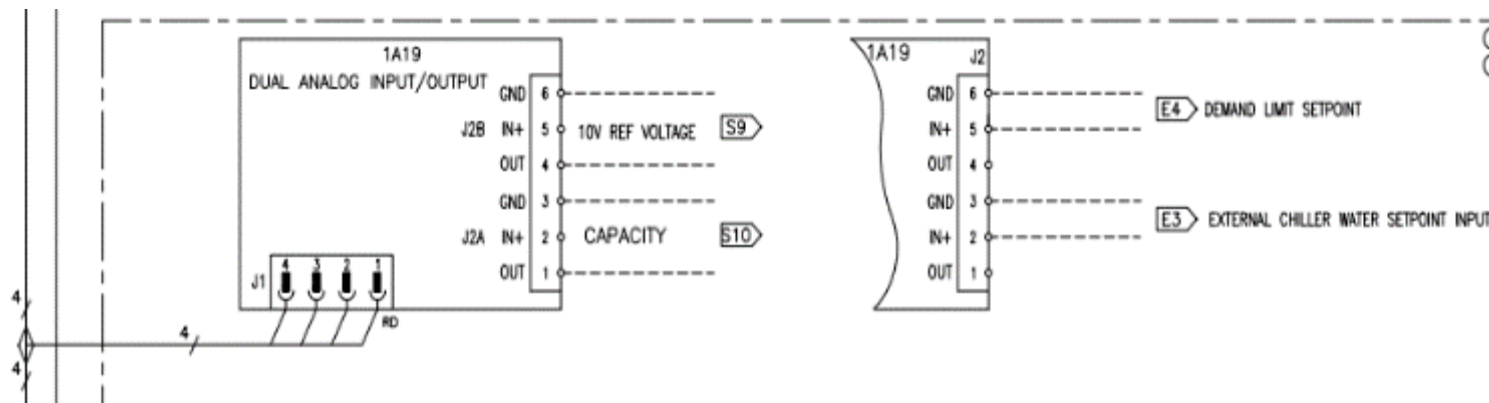

Main options

Digit 31 : Flow switch

To detect if water is flowing into the unit.

It is mandatory to use a flow switch with liquid chillers to stop the unit in case of water flow loss to avoid any water freezing in the evaporator. The flow switch (with paddle type) is not mounted into the unit and it must be placed on the evaporator water piping (see installation detail in the IOM).

In litweb you can find also Flow switch datasheet.



An example of Flow switch

Main options



Digit 33 : Master salve

Simple hard wired solution to enable operation of slave unit when master unit reach maximum capacity.

When the master is at his full capacity, there is activation of the slave like that the master can decompress and they regulate together.

It must be noted that this method does not allow alternating or intelligent switching of which chiller is the lead or lag, nor will it provide the same level of efficiency or optimization as a dedicated chiller plant controller, since it does not take into account part load efficiencies or the design tonnages of the chillers.

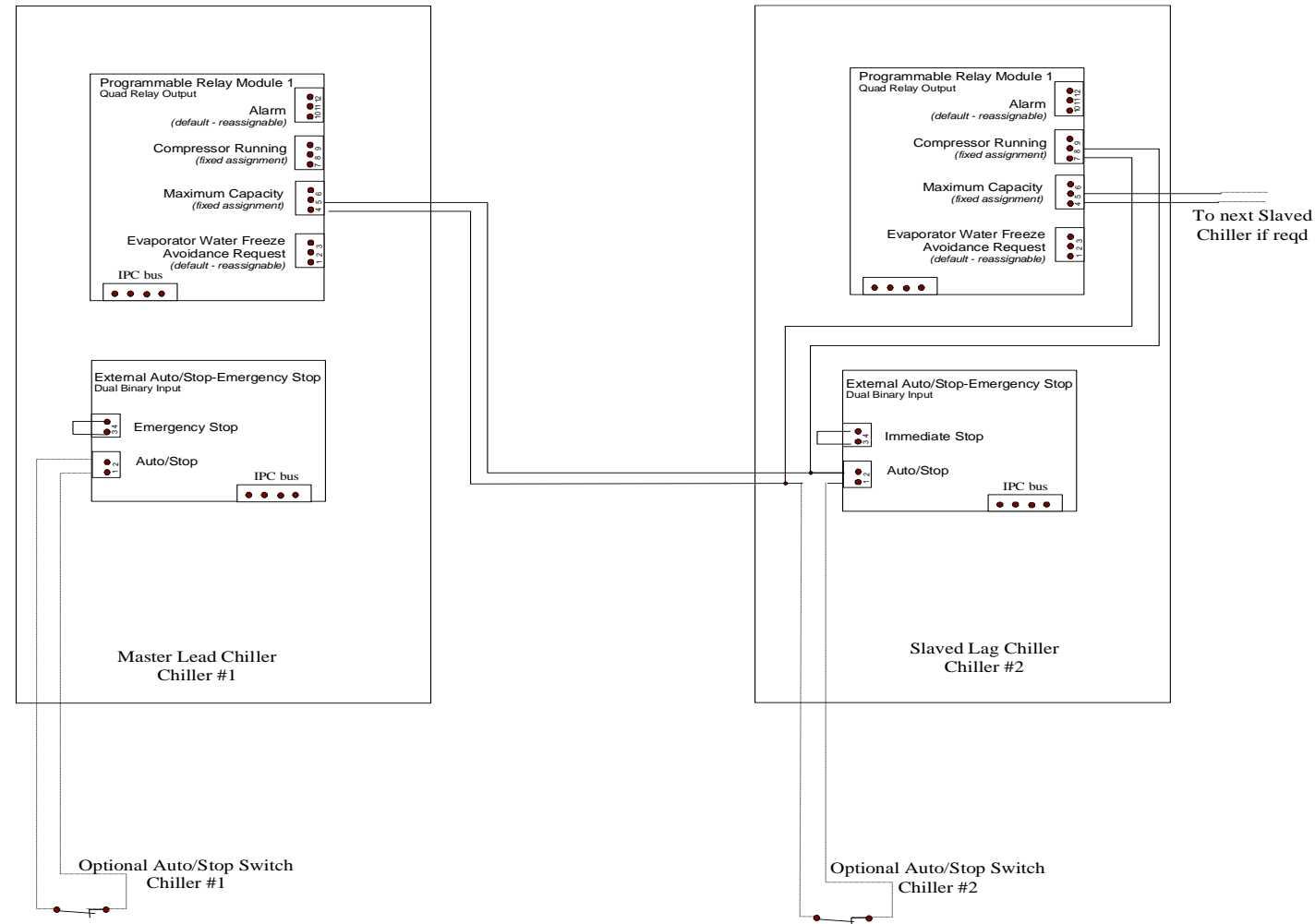

Main options

Digit 35 : Energy meter

The supplier is SOCOMEC.

The energy meter is installed in the electrical panel. It communicates a pulse outlet to the Symbio 800.

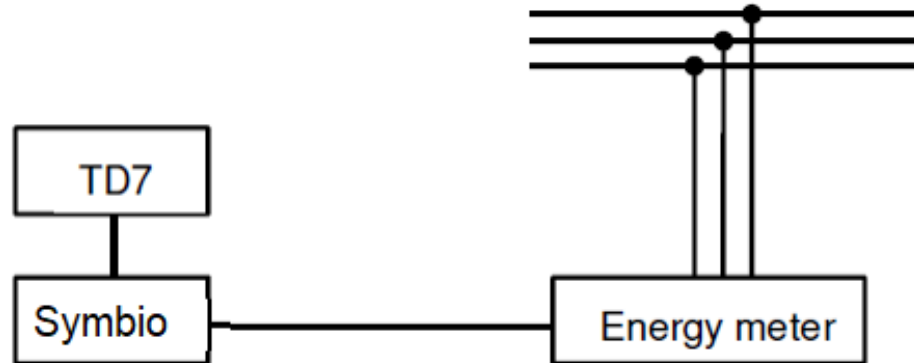

Main options

Digit 37 : Variable primary flow

Constant speed pump_No VFD (digit 37 = X) :

Used as standard on **CGAF/CXAF** units.

No Variable Frequency Drive (VFD) on the unit.

Constant speed pump_VFD Adjustment (digit 37 = F) :

When the water flow must be adjusted by a constant speed pump, no VPF application is possible with a chiller control, but with external control you can change pump's VFD speed.

Used to save energy on the pump consumption

Variable Frequency Drive (VFD) fitted on the unit. For dual pump, there is only one VFD provided.

Constant speed drive

Benefits :

Control of the water flow & Energy saving on the pump consumption



Housing of inverters device for pumps (digit 37)

Main options

Digit 38 : Refrigerant leak detector (only for R454B units)

Why and when to use

To detect a refrigerant leak, which **avoids the risk of the flammability**.

To ensure **safety** for the customer by taking appropriate actions in the case of the leak.

Refrigerant leak detector is available only on **R454B units**. A refrigerant detector is placed in the middle of the unit, close to the compressors

Customer must take appropriate action when leak taction contact closes; Unit control is not taking any action (to avoid risk of sparks inside control panel)



Example of refrigerant leak detector

Main options

Digit 40 : Power Socket

P: Included (230V-100W)

A convenience plug is provided within unit electric box.

The model is M1170 by ABB, able to be directly connected with “Schuko” type or 10/16A – P11/P17 plugs.



Illustration 230V-100W convenience outlet

Digit 41 : Unit inspections

B: Visual Inspection With Customer

The customer will be able to see the unit to check the quality of the construction, the documentation provided with the unit and to check that the unit is in accordance with the order write up.

Main options

Digit 42 : Unit isolators

To avoid direct contact of the unit and the ground or frame.
They are installed at customer care under the unit to reduce vibrations .
Two possible isolators are available: made of neoprene or spring type.
Warning: Isolators are supplied loose in a box. Check Litweb for isolators features.

Neoprene Isolators (Digit 42= 1)



Spring antivibration (Digit 42=6)



Main options

Digit 44 : Shipping package

Standard (Digit 44= X) :

In standard, units are provided with wood skid, a treated wood located under the base frame.



Unit containerization Package (Digit 44= A) :

When the chiller is shipped in a container, Trane adds yellow spacers and hooks to facilitate the transport

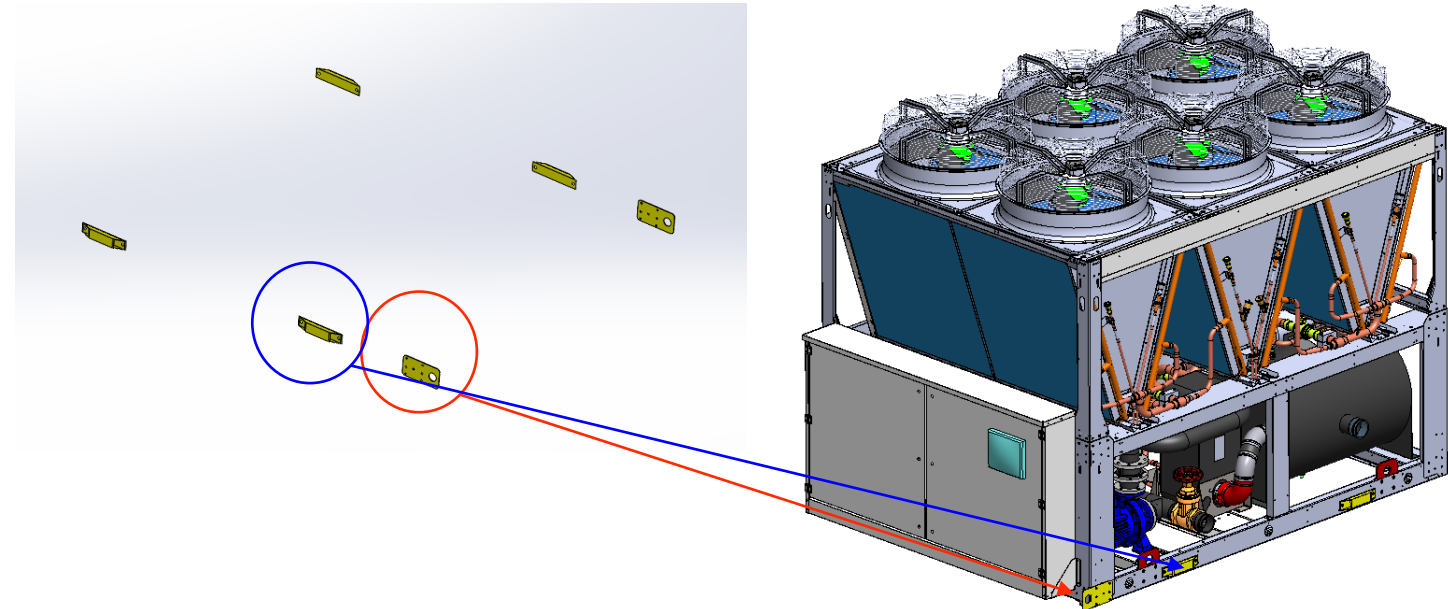

Main options

Digit 46 : Isolator Valve Per Manifold Compressor

Allow to isolate the refrigerant in the condenser of the unit, for each circuit.
This valve allows to isolate the compressor, evaporator, EXV and filter drier from the condenser, for each circuit.
It can simplify maintenance operations.

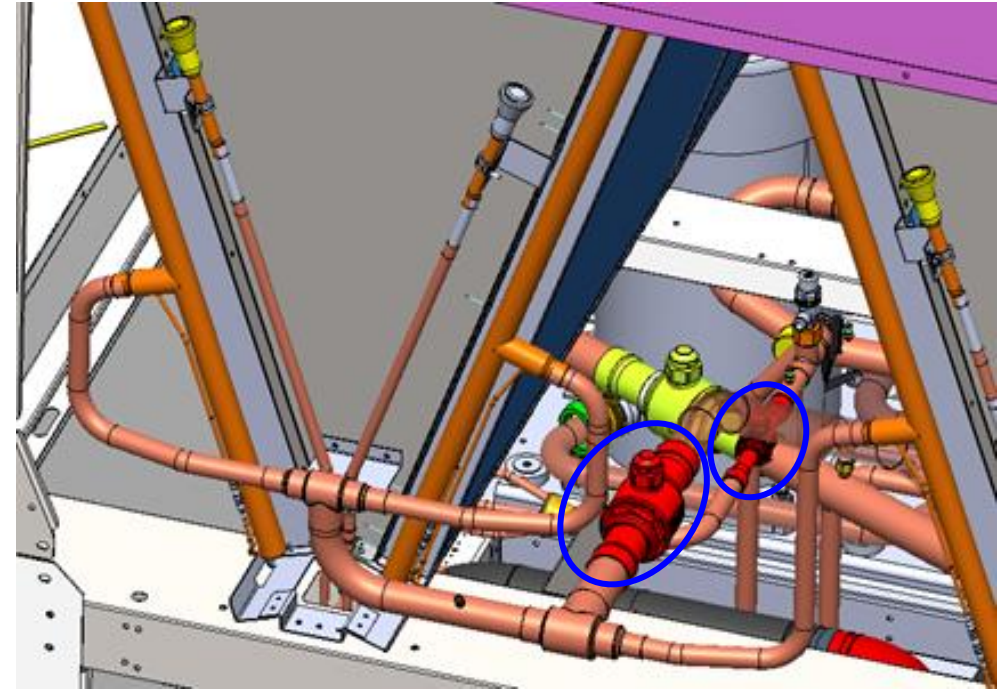

Main options

Digit 47 : Power factor correction capacitors

To reduce the reactive power and therefore the electrical current.
Units have in average a $\cos\phi = 0,87$; thanks to this accessory it moves to ≥ 0.91



Digit 48 : Staged auxiliary heaters command (Only for CXAF)

For CXAF units, it give the possibility to switch on auxiliary hot resources, when needed.
The supplemental heater stages ON / OFF based on Hot water capacity control logic when all available mechanical heating stages are already ON.

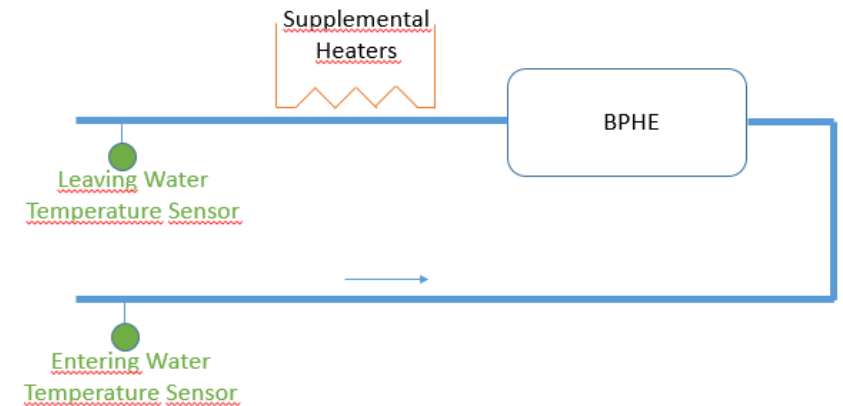

Main options

Digit 49 : Freeze Protection

Thanks to Symbio 800 controller, the anti-freeze protection is possible with the pump activation using external temperature sensor.

Freeze protection for hydraulic modules (Digit 49 = 2)

These kits, aimed at avoiding the freezing of all the components of the hydraulic circuit inside the unit (pumps, pipes and tank) are optional and are coupled to the unit hydraulic versions.

The heating cable type used for the kits mentioned above is featured in the figure below (230 V version):

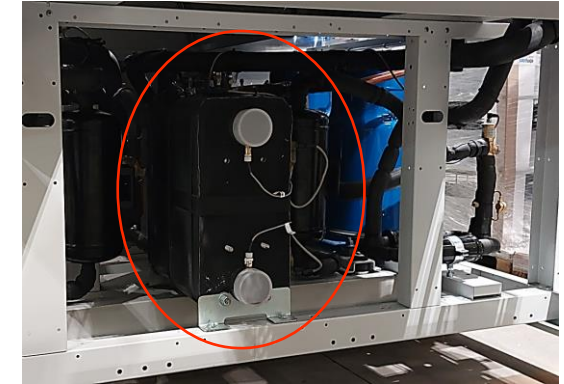
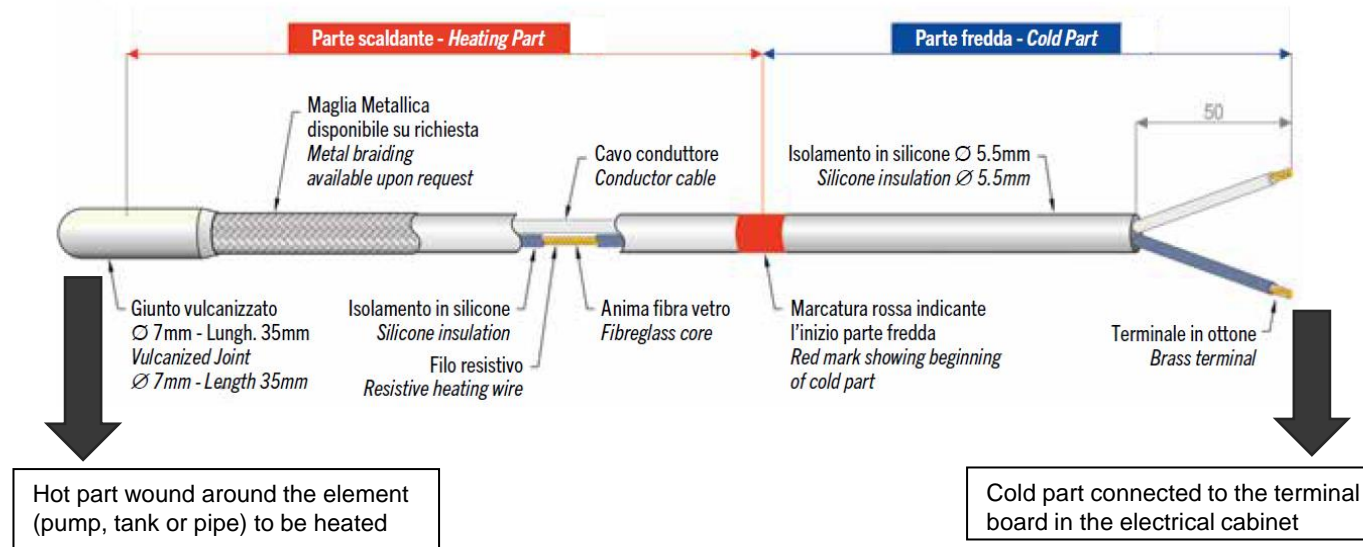

Main options

Digit 50 : Buffer tank

When to use it?

- Used to increase the chilled water circuit inertia.
- Allows to meet the two minutes water loop circulation

How it is made?

- Buffer tank is factory-installed, located on the supply of water loop.
- It is installed after the water pump
- Water tank capacity is
 - **200 liters for sizes on 2V platform**
 - **500 liters for sizes in 2.5 and 3V platform**

Why?

- Ease of installation at the building site
- Increases the compressor life span
- Allows more accurate water temperature

	Water Differential Pressure Switch
	Temperature Probe
	Relief Valve
	Expansion Vessel
	Gauges
	Safety Valve (6 bar)
	Shut Off Valve
	Pump
	Water Charge
	Water Discharge
	Check Valve
	Water Tank
	Antivibration System
	Flow Switch
	Filter

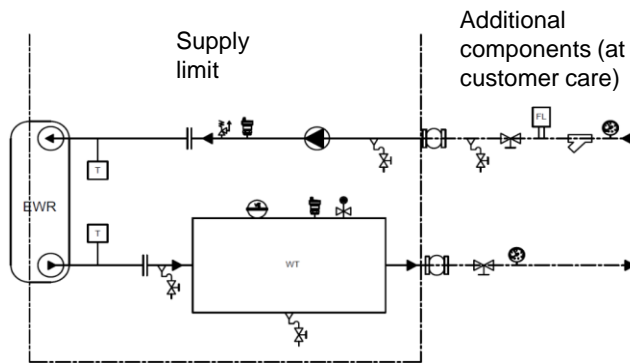

Example of unit with single pump and tank option drawing.

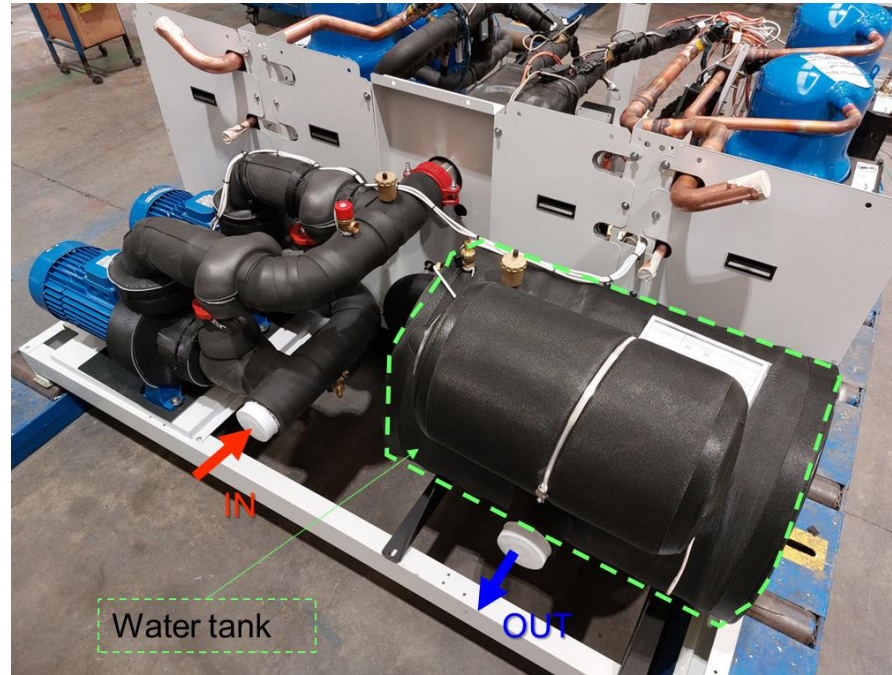

SINTECIS™
ADVANTAGE

Hydraulic module with double pumps and tank on a 2V unit

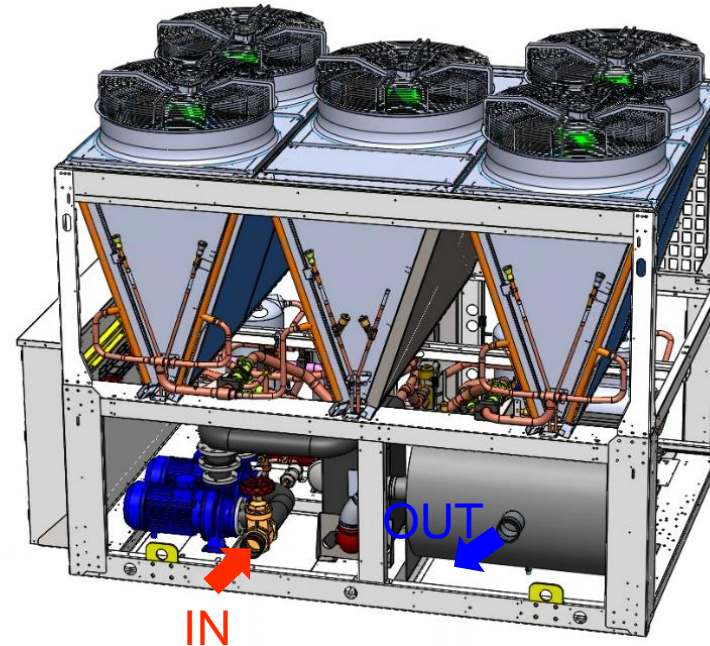

Hydraulic module with double pumps and tank on a 2.5V unit

Main options

Digit 51 : Water strainer

Why?

To filter big impurities into the water, thus it prevents accumulation of the foreign particles in the restricted area as the isolation valves and the brazed plate heat exchange.

How is it made?

“Y” water strainer consists of a body and stainless-steel mesh with meshes not over 0.5mm, with replaceable filter through the inspection cap. Loose accessory, to be installed by customer. The filter is connectable via Victaulic clamps not provided with the kit.

Benefits:

- Increases the life of heat exchanger and isolation valves.
- Heat exchanger and isolation valves are protected.
- Avoid the abrasive effect of flowing particles.
- The customer do not have to dismount completely the strainer for cleaning or changing the filter.



Main options

Digit 52 : Unit appearance

Complete anti-intrusion grilles (Digit 52= B)

Full unit protection grids: To protect the unit and components there installed (upper+ bottom part of the unit is covered by grills)

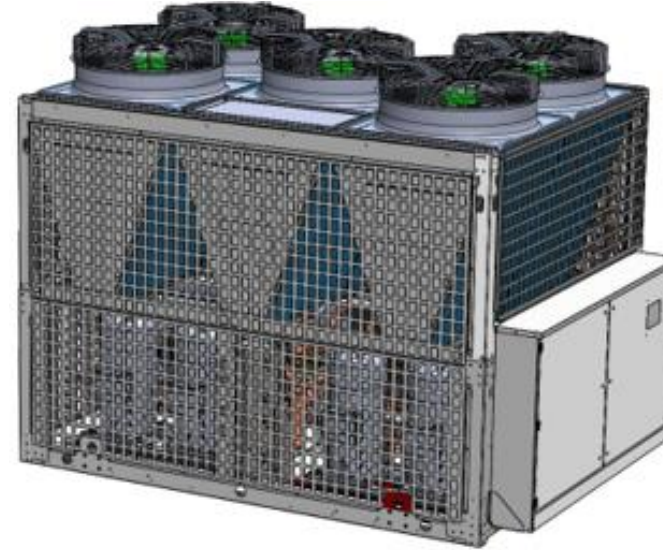

Condensing coil protection grills (Digit 52= C)

To protect just the unit coils (upper part of the unit is covered by grills)

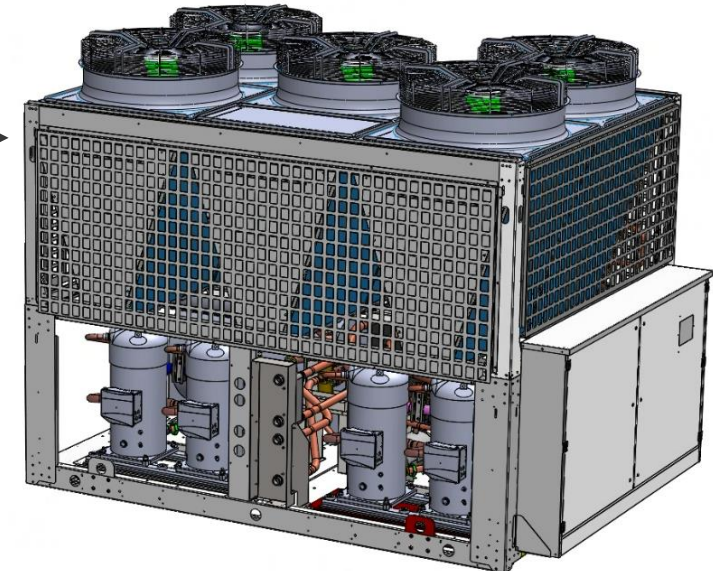

Main options

Digit 52 : Unit appearance

V panels painted (Digit 52= D) available from October 2023

V - shape panels are painted with an epoxy material that provides high corrosion resistance

Complete anti-intrusion grilles with V panels painted (Digit 52= E) available from October 2023

Full unit protection grilles: To protect the unit and components there installed (upper+ bottom part of the unit is covered by grilles) with V - shape panels painted with an epoxy material that provides high corrosion resistance

Condensig coil protection grilles with V panels painted (Digit 52= F) available from October 2023

To protect just the unit coils (upper part of the unit is covered by grilles) with V - shape panels painted with an epoxy material that provides high corrosion resistance

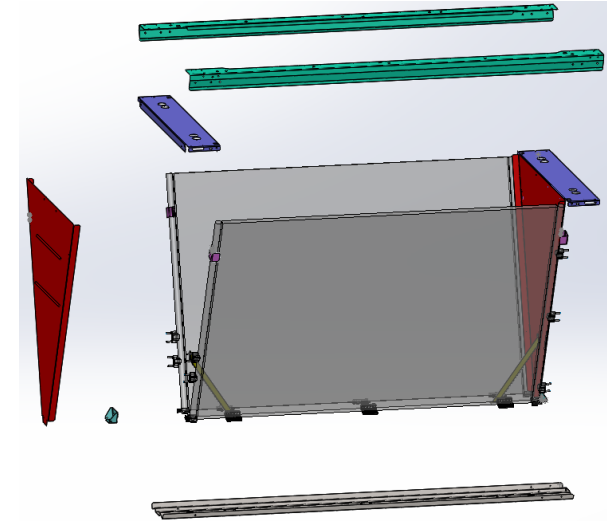
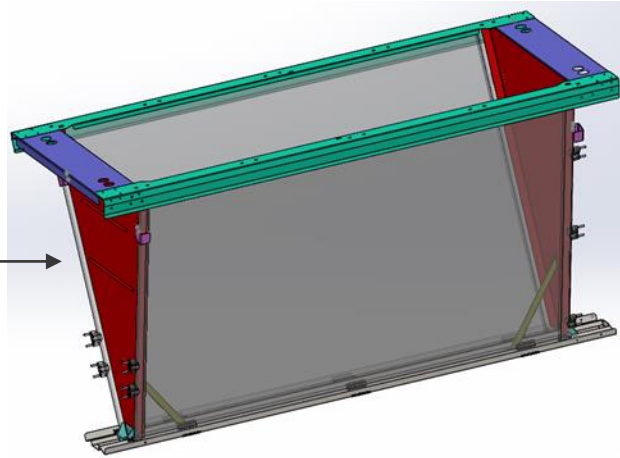

Main options

Digit 54 : Soft starter (Digit 54 = B)

To reduce inrush current when the compressors start.

- In this circuit, the soft starter replaces the direct online starter.
- It controls the current flow which will generate the compressors to start gradually.

Benefits:

- The compressor can start smoothly as the starting current is reduced.
- Smooth starting reduces motor and compressor wear.
- Less stress on the power supply.
- Reduce cable size.



Main options

Digit 55 : Annunciation Relays

When to use it?

When certain events or states of the chiller need to be remotely controlled.

How is it made?

The 4 programmable relays will be energized when the event or state occurs.

Works with Symbio 800.

Available outputs are :

- Alarm - Latching
- Alarm - NonLatching
- Alarm
- Alarm Ckt 1
- Alarm Ckt 2
- Warning
- Chiller Limit Mode
- Compressor Running
- Circuit 1 Running
- Circuit 2 Running
- Maximum Capacity
- Ice Making Status
- Hot Water Control Status
- Defrost Status
- Evaporator Water Freeze Avoidance Request
- Service request (for Unit, Compressor(s) or water pump)



Illustration Relay output card

Main options

Digit 56 : Fan option

AC fan (Digit 56= 1) :

- CGAF SE /CXAF SE are equipped with AC fans. Variable speed control

EC fan (Digit 56= 2) :

- CGAF HE /CXAF HEat are equipped with EC fans always.

EC fan motors are very high efficiency and maintain a high efficiency level at low speed. This means that in most cases they use from less than one third to one half of the electricity used by the traditional "shaded pole" induction motors used in the ventilation and refrigeration industries.

EC fans are class F, IP55 and built-in accordance with EN 61800-5-1.

Benefits :

- Improved capacity modulation
- Reduced power consumption
- Reduced energy costs

HESP fan (Digit 56= 3) : (Only for HE units, both CXAF and CGAF)

The same EC fan as Digit 52=2 are set at higher max. speed, in order to grant up to 80 Pa ESP without affecting unit performances meaningfully.

→ use TOPSS to evaluate new performances with pressure drop on axial fans!

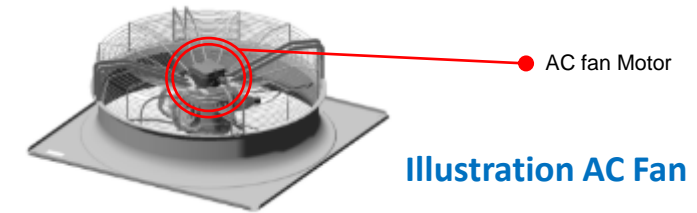

Same grid design as AC fan
With EC motor (5 blades)

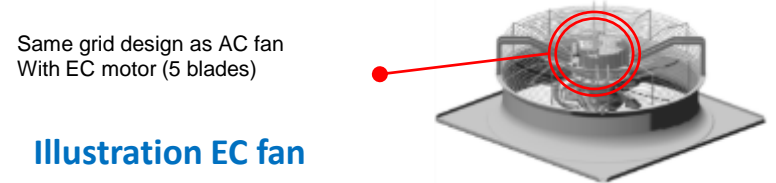

Illustration EC fan motor

Main options

Digit 57 : Night Noise Set Back NNSB (digit 57 = 1)

Useful when fans speed need to be reduced at night.

When NNSB feature is activated via a digital input, fans run at lower speed.

As default, max rpm are reduced by 20% at factory, but it is possible to adjust it.

This option is designed for night operation and ensures exceptional acoustic comfort without compromising efficiency when loads are increased.



In a nutshell



SCROLL



PHE



Cu/Al COIL



MICROCHANNEL



REVERSIBLE



COOLING ONLY



R454B



ErP
Compliant



up to
60°C

SINTECIS™
ADVANTAGE

RANGE

Heating (CXAF) : 127 – 338 kW
Cooling (CGAF) : 137 – 420 kW

WORKING LIMITS

Cooling



-12 ↔ 20°C



-20 ↔ 50°C

Heating



25 ↔ 60°C



-15 ↔ 35°C

CONTROLLER



Symbio 800 and **TD7** touch color display

MAIN ACCESSORIES

- Low noise version down to -3 dB
- Water pump(s) with or without inverter and tank
- PHR
- Phase inversion, anti-freeze kits...
- External card with input and outputs to best fit plant needs
- Master/slave, ice making option, NNSB, ...

APPLICATIONS

COMFORT



Hospitality



Healthcare



Entertainment



Office buildings



Education

INDUSTRY

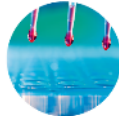

Pharmaceutical industry



Plastic industry



Food and beverage industry

IT COOLING



Data Centers

SELLING POINTS

- **Compact footprint**, including **tank and pumps!**
- **Low weight**, ideal for retrofit in old structures
- Axial fans with variable speed as standard.
- **SCOP** up to **3,74**
- **SEER** up to **5,14**
- **SEPR HT** up to **5.95**



TRANE®