



Product Catalogue

ARIES N - Air-cooled liquid chillers

Refrigerant R290

Model iASN 075 - 150 (170 to 320 kW)



May 2024

CG-PRC060D-GB

TRANE
TECHNOLOGIES



Table of Contents

Technical specifications	4
Selection guide	9
Performances and technical data	10
Pressure drops and available head pressure	12
Working limits & Correction factors.....	14
Overall dimensions.....	15
Installation guide	17

TECHNICAL SPECIFICATIONS

- 1 General
- 2 Acoustic versions
- 3 Configurations
- 4 Nameplate
- 5 Compressors
- 6 Evaporator
- 7 Condensing coils
- 8 Fans
- 9 Refrigerant circuit
- 10 Integrated hydronic module (optional)
- 11 Structure and casing
- 12 Electrical panel
- 13 Control
- 14 Partial heat recovery (optional)
- 15 Options and kits
- 16 Construction configurator

1. General

The iASN water chillers are air-cooled units designed for outdoor installation (IP54 protection rating). All models are configured with independent refrigerant circuits, each with a reciprocating compressor. The condensing section includes micro-channel aluminum coils and EC brushless fans. The evaporator is a brazed plate heat exchanger. As an option, is possible to complete the unit with a hydraulic module, configured with single or double pump and with or without an inertial accumulation tank, to obtain a plug-in system. The units are equipped with a micro-processor electronic controller for the fully independent management of all the main functions, including regulation, alarms and interface with external systems. The targeted design of this range allows to reach high levels of seasonal efficiency compliant with the limits imposed by the ErP EcoDesign Regulation. Advanced technologies and the application of natural refrigerant R290, with zero environmental impact, are combined in iASN

chillers, offering a long-term sustainable solution. The iASN chillers are designed built and tested in compliance with ISO 9001 and are fitted with components made by premium manufacturers. The standard product, destined for EU and EFTA countries, is subject to the following directives:

- ErP Directive 2009/125/CE;
- Machinery Directive 2006/42/EC;
- Electromagnetic Compatibility Directive 2014/30/UE;
- Pressure Equipment Directive 2014/68/UE.

The electrical equipment is designed in compliance with EN 60204-1. All data in this catalogue refers to standard units without accessories/options which require an electrical feeding source and in nominal working conditions (unless otherwise specified).

2. Acoustic versions

The iASN are available with the following acoustic versions:
"HE" – Basic acoustic version for low noise operation: standard integral enclosure with soundproofing panels;
"SHE" - Silent acoustic version, optimized for very low noise operation: standard integral enclosure with soundproofing

panels configured; EC brushless fans with reduced operating ramp to further optimize the noise emissions compared to the HE acoustic version.

3. Configurations

The iASN are available with the following configurations:
"STD" – Standard configuration: suitable to operate with outlet cooling fluid temperatures from +20 °C to 0 °C;
"MWT" - Configuration for low water temperature at the evaporator outlet (down to -10 °C): compared to the STD, the MWT configuration is designed to operate with low evaporation value

and the increased thermal insulation of the hydraulic prevents the creation of condensation. This configuration is suitable to operate with outlet cooling fluid temperatures from 0 °C to -10 °C. It's mandatory to protect the hydraulic circuit with anti-freeze additives in suitable concentration. This configuration is available for HE acoustic version only.

4. Nameplate

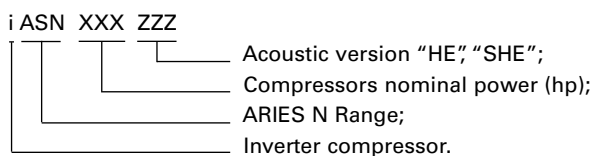

5. Compressors

All iASN models are equipped with two reciprocating semi-hermetic compressors featuring 4, 6 and 8 cylinders, connected in two independent refrigerant circuits. The compressors configuration is 1+i for each refrigerant circuit with one compressor regulated by inverter and one compressor with on/off control. This configuration and capacity control deliver high efficiency at both full load (EER) and partial load for process applications (SEPR HT for STD configuration and SEPR MT for MWT configuration). The use of variable frequency drive technology on a compressor improves efficiency in any load condition to meet the latest efficiency threshold, set by EcoDesing regulation, for comfort applications (SEER). The semi-hermetic reciprocating compressors fitted on the iASN range are ATEX certified in 3G category (high protection level - Zone 2) and are designed for ensuring maximum reliability. The standard equipment con-

sists of IP65 electric terminal box, oil level sight glass and shut-off valves on suction and discharge line. The compressors are supplied with a discharge temperature cut-off device that stops the compressor if the discharge temperature exceeds the safety limit. An electronic pressure switch on the oil pump monitors the differential pressure in the compressor lubrication system and protect the compressors in the case of unexpected measurements. A chain of sensors connected to the electronic control module monitor the compressor operation to reduce the risk of damage in the event of thermal overload due to electric motor or mechanical issues. The compressors ensure further benefits like reduced pressure drops on the suction side, high compression efficiency, long working life with zero maintenance requirements, and very low levels of vibrations and noise emissions.

SEER

The Seasonal Energy Efficiency Ratio (SEER), used in the European design context, expresses the ratio between the cooling demand and the total absorbed power of the unit during the entire year of operation, considering the maximum operating load point (Tw 12/7 °C - external air temperature 35 °C) and the three partial load point with lower ambient temperature projected on the average annual temperature in Strasbourg. The higher SEER value is, the more energy efficient of the unit will be, considering the annual air conditioning context with outlet water temperature 7 °C.

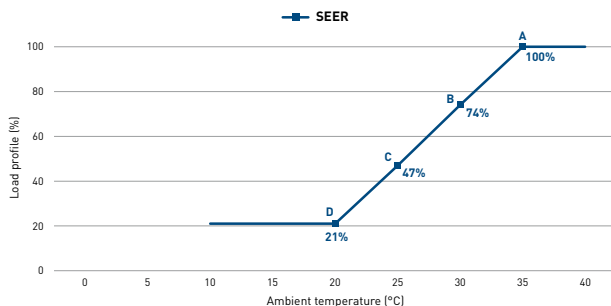

SEPR HT

The Seasonal Energy Performance Ratio High Temperature (SEPR HT), used in the European design context, expresses the ratio between the cooling demand and the total absorbed power of the unit during the entire year of operation, considering the maximum operating load point (Tw 12/7 °C - external air temperature 35 °C) and the three partial load point with lower ambient temperature projected on the average annual temperature in Strasbourg. The higher the SEPR HT value is, the more energy efficient of the unit will be, considering the annual process cooling context with outlet water temperature 7 °C.

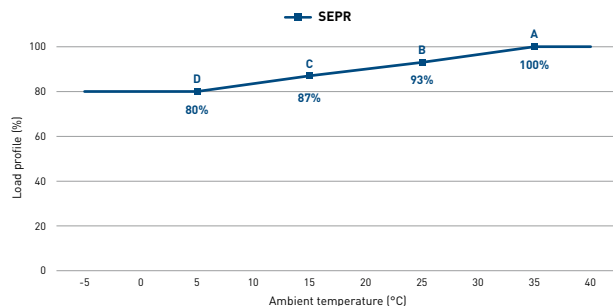

SEPR MT

The Seasonal Energy Performance Ratio Medium Temperature (SEPR MT), used in the European design context, expresses the ratio between the cooling demand and the total absorbed power of the unit during the entire year of operation, considering the maximum operating load point (Tw -2/-8 °C - external air temperature 35 °C) and the three partial load point with lower ambient temperature projected on the average annual temperature in Strasbourg. The higher the SEPR MT value is, the more energy efficient of the unit will be, considering the annual process cooling context with outlet water temperature -8 °C.

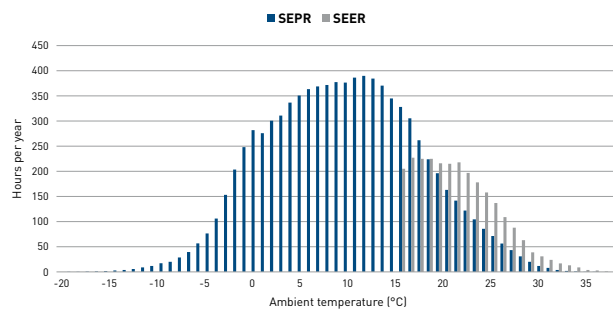

6. Evaporator

The evaporator is brazed plate heat exchanger (BPHE); a package of corrugated 316/316L stainless steel plates and copper brazing. It combines low water pressure drops with high performance in a single water circuit and a double refrigerant circuit configuration delivering high efficiency at both full and partial load. The evaporator is externally insulated with thermal and anti-condensation cladding in closed cell elastomer foam. The protection from freezing risk, potentially caused by low evaporation temperatures, is managed by the anti-freeze function integrated in the programmable electronic control, which monitors the water outlet temperature. In addition,

each evaporator is equipped with a flow switch to avoid operations with low water flow rate values. The installation of a water filter on the unit evaporator inlet is compulsory to intercept any debris in the water supply that may otherwise deposit in the evaporator or on a storage tank for configuration with integrated hydraulic module. All evaporators are compliant with the "EC" pressure vessels directive and can handle anti-freeze solutions and, in general, all other liquids that are compatible with the hydraulic circuit materials. BPHE evaporators are approved by European Pressure Equipment Directive (PED), III category.

7. Condensing coils

The condensing coils are micro-channel heat exchangers made of highly resistant and durable aluminum alloy, delivering reduced air pressure drops and a decrease of the amount of refrigerant used up to 30%, maintaining high energy efficiency. The coils are arranged modular transverse "V" formation, to optimize the ratio between the thermal exchange surface area and the footprint. These exchangers are calculated, sized, and designed utilising the latest technology and allow the use of reduced speed fans ensuring a further improvement in the noise emissions features of the unit. As an option the protective paint treatment is availa-

ble. The surface is protected by an epoxy-acrylic resin based organic coating, then the whole condenser is coated with a reticulated polyester resin thermosetting powder coating. The condensing coils can be protected through metal mesh filters available as factory fitted or as separately kit with installation at customer care.

8. Fans

The fans, complete with protective grills, are EC brushless type with sickle-shaped blades in die-cast aluminum. The aerodynamics of the blades, developed based on bionic principles, achieves high performances with reduced of sound levels. The electric motor forms a single unit with the fan wheel and integrates an overload protection device. The protection rating is IP54 with insulation class F to ensure outdoor operation in all ambient conditions. The EC electronic switching technology, thanks to the continuous adjustment of fans speed and efficiently at partial

loads, allows a high noise reduction in the main operating conditions and an accuracy control of the condensing pressure, allowing to the units the functioning even at low ambient temperatures. In the SHE acoustic version the EC brushless fans are configured with reduced regulation ramp for a lower noise emission compared to the HE acoustic version.

9. Refrigerant circuit

Each refrigerant circuit, in the base configuration of the iASN units, is configured as follows:

- semi-hermetic reciprocating compressors;
- pressure switches to control the maximum condensation pressure as prescribed by EN378 standards;
- high pressure transducer: read and display the condensing pressure, alarms management, unloading function, adjustment of condensing pressure through the regulation of EC brushless fans;
- relief valve in the high pressure side (according to EN378 standards);
- relief valve in the low pressure side (according to EN378 standards);
- condensing coils;
- refrigerant shut-off valve on the liquid line;
- refrigerant filter with removable cartridge;
- liquid flow sight glass;
- electronic expansion valve that allows the improvement of cooling performances in a context that is much wider compared to the mechanical thermostatic valve. The outlet water

temperature fluctuation reduction and a great precision during operation at partial loads are the main benefits of this device;

- BPHE evaporator;
- low pressure transducer: for alarm management, read and display the evaporating pressure;
- refrigerant/refrigerant heat exchanger for MWT version;
- non-freezing oil and refrigerant charge.

The whole brazing for connection of the various components is made with silver alloy and low pressure side refrigerant pipes are coated with heat-insulation material to prevent the creation of condensation.

All the components included in the refrigerant circuit compartment are ATEX certified.

10. Integrated hydronic module (optional)

The iASN units can be configured with a hydronic module composed by:

- Single or double pump (stand-by operation and automatic commutation) equipped with motors compliance with European Regulation N.640/2009, available with standard (2 barg - P2) or increased pressure head (3 barg - P3), installed down-line from the storage tank and equipped with shut-off valves on the inlet. The double pump configuration is composed by twin in-line version type.
- Storage tank, installed on the evaporator outlet line, made of carbon steel with external thermal insulation material and

anti-condensation cladding. All storage tanks are delivered with an automatic air bleed valve, manual air bleed valve, expansion vessel, 3 barg pressure relief valve, water level sensor and drain valve.

- Water pressure gauge on the pump pressure line, to show the pressure in the hydraulic circuit (with chiller off) or pump delivery pressure (with chiller on). The water pressure gauge is included in the configurations with built-in pump only.

11. Structure and casing

The base and outer panels are made of galvanized carbon steel sheet subjected to a phosphor degreasing treatment and painted with a polyester powder coating baked-on at 180 °C to provide a durable weatherproof finish. The base is finished in orange-peel blue RAL 5013P, while the remaining parts of the frame and panels are finished in orange-peel light grey RAL 7035P. The standard unit is equipped with integral enclosure. All the main components of the refrigerant circuit (e.g. compressors, EEV), ATEX zone 2 certified, are housed in a dedicated compartment that is mechanically ventilated. The compartment is equipped with a leak detector, which cuts the power supply to the main compo-

12. Electrical panel

The unit and electrical panel are manufactured in conformity with EN 60204-1 (Safety of machinery – Electrical equipment of machines – Part 1: General rules) protection against the weather is ensured such as to allow outdoor installation of chillers (IP54 protection rating). The electrical panel, with forced ventilation, is equipped with a main circuit breaker with door-lock device and contains the automatic thermal-magnetic cut-outs to protect the compressors and pumps, and magnetic-only automatic cut-outs for fans (the thermal protection is integrat-

13. Control

Control and management of the unit are provided by the electronic controller connected to the touch screen user terminal with a 480x272 pixel screen. Thanks to the touch icons, with dynamic description and moving images, the displays and information are easy to interpret, by both trained personnel and the system operator even if not specifically trained on the use of the controller. The terminal is located on the door of the electrical cabinet and is protected by an openable polycarbonate cover.

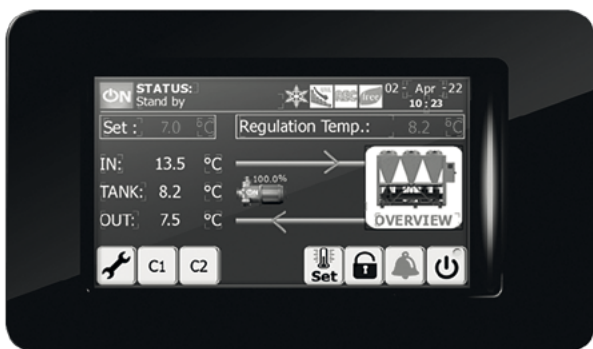

The controller manages the following main functions independently:

- Temperature control of water at the evaporator outlet;
- Compressors start cycles, timing, run times equalization;
- Unloading function that allows system starting and unit operation with parameters that differ significantly from nominal conditions;
- Management of electronic expansion valves;
- Set-point management:
 - “fixed” (standard);
 - “compensated” in accordance with external air temperature;

ments and activates the fan at maximum speed to perform the complete air change. The hydraulic components (optional pumps and storage tank) are housed in a separate compartment. The unit frame is designed to ensure easy access to all components. The hydraulic connections of the iASN units are directly accessible from the external of the unit; connections are “Victaulic” type with stub pipe and coupling (Victaulic hydraulic connections kit supplied as standard with each unit). The units are equipped with eyebolts for lifting and handling using belts.

ed in the fan). The control section includes a transformer for the auxiliaries’ circuits and the microprocessor board. In iASN units, the inverter coupled to the compressor is installed inside the electrical panel. To ensure the protection against phase loss or wrong phase reversal is provided as standard the phase monitor device. All cables and connectors are marked and simply identifiable for easier maintenance.

- “dual” set by a digital signal;
- “variable by analogue signal” 4÷20 mA or 0-10V;
- On/off by daily and/or weekly time bands;
- EC brushless fans speed control in accordance with condensing pressure;
- Management of fans with “low-noise” function that makes it possible to reduce fan noise levels in accordance with programmable time band;
- Visualization of energy data (for unit configured with energy meter option);
- Anti-freeze control in accordance with the water temperature at the evaporator outlet;
- Pumps timing and management of the 2nd pump in stand-by, with automatic change-over in the case of a fault on the main pump and for equalization of run times on the basis of:
 - number of operating hours (standard);
 - on-off (at the time of unit start-up the pump that was previously stopped is started);
- Count of operating hours of the unit, compressors and pumps with notification when the programmed operating hours before maintenance is exceeded;
- Management of alarm messages, including:
 - low evaporation pressure alarm;
 - high condensing pressure alarm;
 - compressor thermal protections trip alarm;
 - fans thermal protection trip and fans absorption power (through ModBus);
 - pump thermal protections trip alarm (optional);
 - flow switch trip alarm due to reduced water flow to the evaporator;
 - high and low temperature water inlet and outlet alarms, anti-freeze alarm;
- Alarm device for minimum/maximum voltage (tolerance +/-10%) and phase sequence error.

In addition to alarms, the display can also present the following main information:

- Condensing and evaporation pressure values of each circuit;
- Inlet and outlet water temperature and external air;
- Status of digital inputs and outputs of the electronic controller;
- Alarms history;
- Language selection (Italian, English, French, German, Spanish and Russian).

14. Partial heat recovery (optional)

By means of an additional plates heat exchanger in series with the condenser is possible to recover about 20% of rejection heat to produce hot water. The recovery exchanger is externally clad with thermal insulation to avoid heat dispersion; in addition to this features a manual air bleed valve located on the top and a drain valve at the bottom. The connections on the water side are easily accessible from the external. This option is not available combined with integrated hydronic module including storage tank.

15. Options and kits

Options (the options must be specified at the time of the order because they are installed in the factory):

Low ambient air temperature

- Low ambient air temperature option (down to -20 °C): this option is composed by a heating element controlled by a thermostat installed in the electrical panel. Is recommended to match this option with anti-freeze additives mixture in appropriate concentration in the hydraulic circuit.

Refrigerant and hydraulic circuit

- Partial heat recovery (see chapter 14);
- Nitrogen refrigerant charge: if for safety reasons regarding transport and handle the unit must be supplied without refrigerant is possible to provide a nitrogen charge. For units configured with this feature the final R290 refrigerant charge on installation site will be at customer/installer care; if the unit will be shipped by container, it is always mandatory to select and order the unit with nitrogen charge only;
- Protective paint treatment for condensing coils (see chapter 7);
- Protective metal mesh filters for condensing coils (see chapter 7);
- Integrated hydronic module (see chapter 10);
- Anti-freeze protection heaters: adhesive heating elements installed in the evaporator and all components composed the hydraulic module if configured. Controlled by the on-board electronic controller in accordance with ambient air temperature. These heaters protect the equipment when ambient air temperature value is below 0 °C and higher or equal to -10 °C. For ambient temperatures below -10 °C and above -20 °C you must provide an adequate quantity of anti-freeze mixture solutions;

Electrical equipment

- Energy meter: the energy meter provides a solution for measuring energy data. This device, installed inside the electrical panel and connected to the electronic controller, allows to monitor the energy data directly from the on-board display.

In addition, the unit features a remote general alarm. The controller is equipped with RS485 serial output with ModBus communication protocol for the connection to applications developed by third party System Integrators, for local and remote control and an Ethernet port for connecting to a LAN network through which you can access the controller display emulator to display/modify the operating parameters of the unit.

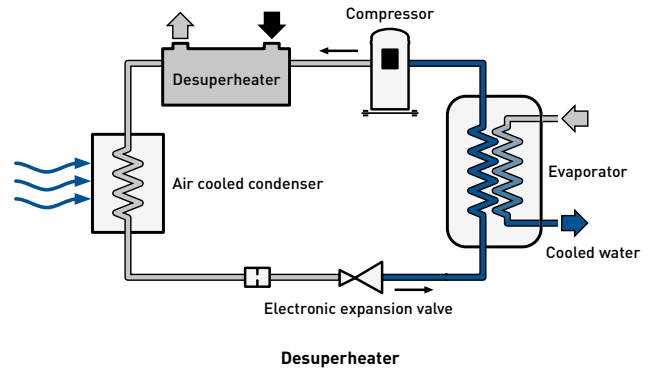

Kits (the kits are supplied separately, generally at the same time of the unit, and installed by the user. They can be supplied later as spare parts, modification kits, completion kits, etc.):

- “Victaulic” hydraulic connections kit: this kit is delivered as standard with each unit;
- Protective metal mesh filters for condensing coils (see chapter 7);
- Anti-vibration mounts;
- Modularity kit: allows the connection of multiple units in parallel by means Ethernet connection to create a modular system (from 3 to 4 units). The kit’s control system manages the units and compressors on/off to guarantee the same operating hours between the different loads. The modularity between 2 units can be managed without using the kit through direct connection with a crossed RJ-45 Ethernet cable (not supplied).

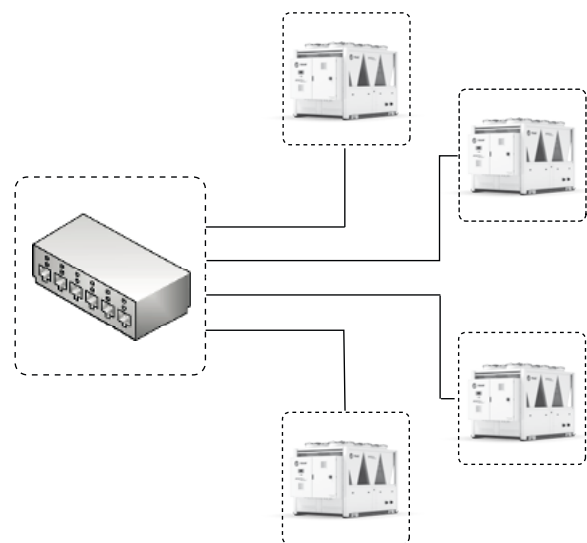

16. Construction configurator

By combining the versions, configurations and options described above the units can be customized to meet a very broad range of plant requirements.

WARNING: when configuring the unit it should be remembered that not all combinations are possible.

	FEATURES	AVAILABLE OPTIONS	NOTE
1	ACOUSTIC VERSION	HE	
		SHE	
2	CONFIGURATION	STD	
		MWT	available for HE version only
3	ENERGY METER	STANDARD (not included)	
		INCLUDED	
4	EXTERNAL AIR TEMPERATURE	STD (-10 °C)	
		LOW AMBIENT TEMPERATURE OPTION (-20 °C)	
5	INTEGRATED HYDRONIC MODULE	WITHOUT	
		SINGLE P2 PUMP	
		SINGLE P3 PUMP	
		DOUBLE P2 PUMP	
		DOUBLE P3 PUMP	
		STORAGE TANK + P2 PUMP	not combinable with partial heat recovery
		STORAGE TANK + P3 PUMP	
STORAGE TANK + DOUBLE P2 PUMP			
6	HEAT RECOVERY	STANDARD (not included)	
		PARTIAL HEAT RECOVERY	not combinable with integrated hydronic module configured with storage tank
7	REFRIGERANT CHARGE	STANDARD (R290)	
		NITROGEN	mandatory with container packing
8	HYDRAULIC ANTI-FREEZE PROTECTION	STANDARD (not included)	
		ANTI-FREEZE PROTECTION HEATERS	
9	CONDENSING COILS TREATMENT	STANDARD (not included)	
		PROTECTIVE PAINT TREATMENT	
10	CONDENSING COILS PROTECTION	STANDARD (not included)	
		PROTECTIVE METAL MESH FILTERS	

SELECTION GUIDE

For a proper chiller selection is necessary to:

- 1) Observe the operational limits as indicated in the chart "WORKING LIMITS";
- 2) To verify that the water flow rates are within the min and max limits which are described in the "GENERAL DATA" table. A very low flow can cause laminar flow and thus danger of ice formation and poor unit control. A very high flow can cause great pressure drops and the possibility of tube failure inside the evaporator;
- 3) For working temperatures below 6 °C outlet water is necessary to add ethylene glycol or any other antifreeze additives. Consult the "SOLUTIONS OF WATER AND ETHYLENE GLYCOL" table to determine the necessary quantity of ethylene glycol, the reduction of cooling capacity, the increase of power absorbed by the compressors, the increase of evaporator pressure drop due to the presence of the ethylene glycol;
- 4) If the unit is to be installed at an altitude higher than 500 meters, you must calculate the cooling capacity reduction and the increase of absorbed power by the compressor through the coefficients pointed out in the chart "CONDENSER CORRECTION FACTORS";
- 5) When the difference in terms of temperature between water inlet and outlet is different from 5 °C, the cooling capacity and the absorbed power must be corrected using the " $\Delta T \neq 5$ °C CORRECTION FACTORS" table.

PERFORMANCE AND TECHNICAL DATA

GENERAL DATA

		075		100		110		150	
		HE	SHE	HE	SHE	HE	SHE	HE	SHE
Cooling capacity (1)	kW	170,2	166,2	215,5	211,1	259,8	252,5	318,9	309,5
Total absorbed power (1)	kW	61,2	60,2	76,6	74,3	95,6	94,0	112,5	109,3
EER (1)	-	2,78	2,76	2,81	2,84	2,72	2,69	2,84	2,83
SEER (2)	-	4,10	4,11	4,15	4,14	4,12	4,10	4,10	4,11
SEPR HT (3)	-	5,34	5,36	5,58	5,75	5,02	5,04	5,10	5,13
SEPR MT (4)	-	3,85	-	3,94	-	3,68	-	3,58	-
Compressors									
Cooling circuits	N°	2							
Refrigerant charge C1 / C2	kg	4 / 5		6 / 6		7 / 7		8 / 8	
Compressors	N°	1 on/off + 1 inverter							
Capacity control	%	25 - 100							
Electrical power supply									
Power	V/Ph/Hz	400 ± 10% / 3 - PE / 50							
Auxiliary	V/Ph/Hz	24 - 230 ± 10% / 1 / 50							
Protection class	-	IP54							
Condenser coils									
Coils	N°	4	4	6	6	6	6	8	8
Total frontal surface	m ²	8,4	8,4	12,6	12,6	12,6	12,6	16,8	16,8
Fans									
Fans	N°	4	4	6	6	6	6	8	8
Total airflow	m ³ /h	80000	60800	120000	91200	120000	91200	160000	121600
Nominal power (each)	kW	1,35	0,6	1,35	0,6	1,35	0,6	1,35	0,6
Plate evaporator									
Min/max evaporator flow rate	m ³ /h	10/60		10/60		15/108		15/108	
Evaporator water volume	l	22		22		39		48	
Sound levels									
Sound power (5)	dB (A)	93,2	85,9	95,1	87,6	95,2	87,9	96,6	89,3
Sound pressure (6)	dB (A)	65,2	57,9	67,1	59,6	67,2	59,9	68,6	61,3
Dimensions and weights (7)									
Width	mm	2238		2241		2241		2241	
Length	mm	3541		3541		3541		4531	
Height	mm	2475		2475		2475		2475	
Installed weight	kg	2242		2368		2631		3341	

Data declared according to UNI EN 14511:2018.

- (1) Evaporator water temperature IN/OUT 12/7 °C and external air temperature 35 °C;
- (2) Data declared in compliance with the European Regulation (EU) 2016/2281 for cooling products (air conditioning applications);
- (3) Data declared in compliance with the European Regulation (EU) 2016/2281 and high temperature process chillers;
- (4) Data declared in compliance with the European Regulation (UE) 2015/1095 for medium temperature process chillers;
- (5) Determined on the basis of measurements taken in accordance with the standard ISO 3744.
- (6) Average value obtained in free field on a reflective surface at a distance of 10 m from the external side of the electrical panel of the unit and at height of 1.6 m by the unit foothold. Considered tolerances ± 2 dB. The sound levels are referred to the full load operations in nominal working conditions;
- (7) Dimensions and weights are referred to iASN without options and with water content. According to the chosen configuration the weights could vary up to +20%.

ELECTRICAL DATA

Model	Version	Without pump			With P2 pump/s			With P3 pump/s		
		FLI (kW)	FLA (A)	ICF1 (A)	FLI (kW)	FLA (A)	ICF1 (A)	FLI (kW)	FLA (A)	ICF1 (A)
075	HE	66	115	313	70	122	320	74	129	327
	SHE	64	107	305	69	115	313	73	121	319
100	HE	86	152	377	92	163	388	95	166	391
	SHE	84	140	365	90	151	376	93	155	380
110	HE	106	191	391	112	201	402	116	208	409
	SHE	104	179	380	111	190	390	114	196	397
150	HE	129	231	505	137	245	519	139	248	522
	SHE	126	215	490	135	229	504	136	232	507

FLI = max absorbed power at working limit conditions;

FLA = max absorbed current at working limit conditions;

ICF1 = start-up current at the start of the last compressor at working limit conditions.

SOUND LEVELS

Model	Version	Octave bands (Hz)								Power	Pressure
		63	125	250	500	1000	2000	4000	8000		
		Sound power level Lw dB (A)								dB (A)	dB (A)10m
075	HE	57,3	79,3	80,9	83,7	89,9	86,4	82,7	77,2	93,2	65,2
	SHE	58,4	67,8	73,9	78,2	82,3	78,0	76,6	70,0	85,9	57,9
100	HE	59,2	81,1	82,8	85,6	91,7	88,3	84,4	78,9	95,1	67,1
	SHE	60,2	69,6	75,7	80,0	84,0	79,7	78,2	71,5	87,6	59,6
110	HE	59,2	81,1	82,8	85,6	91,9	88,4	84,9	79,3	95,2	67,2
	SHE	60,2	69,6	75,8	80,1	84,3	80,1	78,9	72,4	87,9	59,9
150	HE	60,5	82,5	84,1	87,0	93,2	89,7	86,3	80,8	96,6	68,6
	SHE	61,5	71,0	77,1	81,4	85,7	81,5	80,4	73,9	89,3	61,3

Sound power: determined on the basis of measurements taken in accordance with the standard ISO 3744.

Sound pressure: average value obtained in free field on a reflective surface at a distance of 10 m from the external side of the electrical panel of the unit and at height of 1.6 m by the unit foothold. Considered tolerances ± 2 dB. The sound levels are referred to the full load operations in nominal working conditions.

Distance (1) L (m)	Sound pressure increase in dB(A)
1	15
3	10
5	6
10	0

(1) To calculate a different distance of the sound pressure level, use the formula: sound pressure level dB(A)L=sound pressure level dB(A)10m+sound pressure increase dB(A) corresponding to the new required distance.

PRESSURE DROPS AND AVAILABLE HEAD PRESSURES

EVAPORATOR PRESSURE DROPS

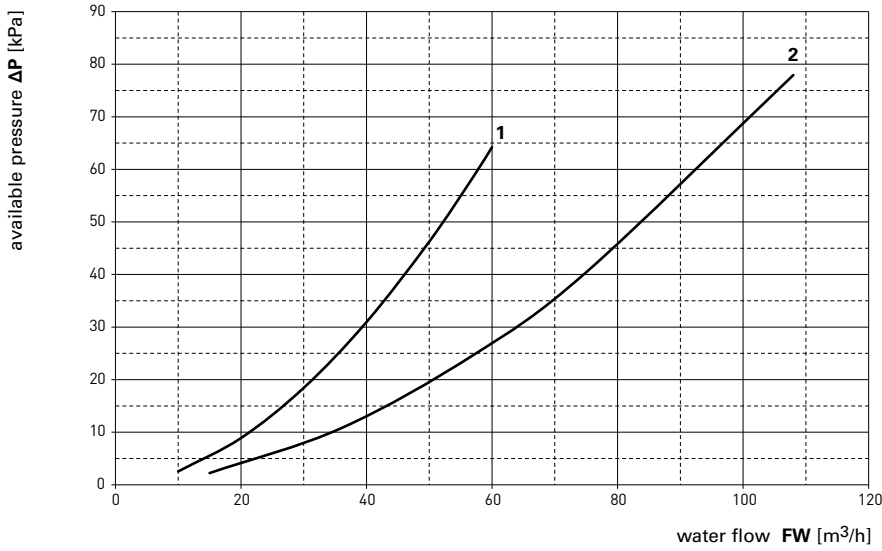

1: iASN 075- 100
2: iASN 110- 150

AVAILABLE PRESSURE AT CHILLER CONNECTIONS WITH PUMP P2

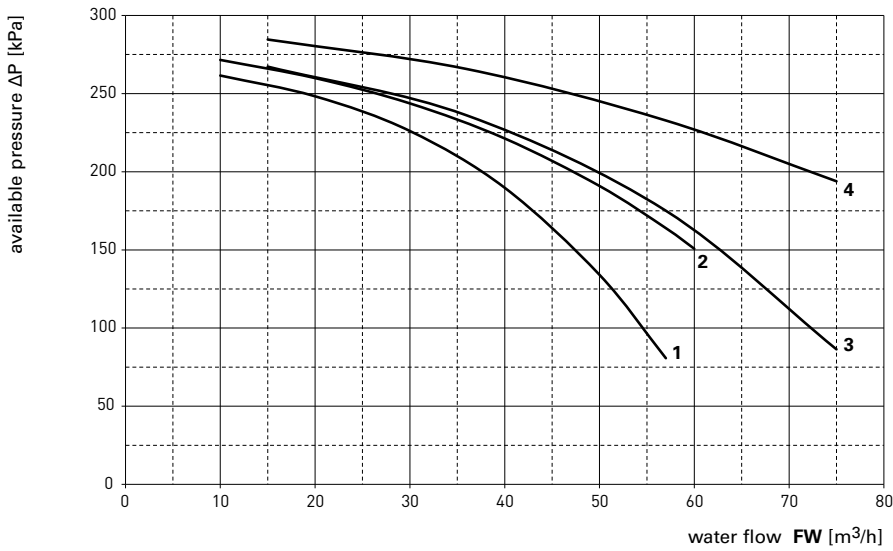

1: iASN 075
2: iASN 100
3: iASN 110
4: iASN 150

AVAILABLE PRESSURE AT CHILLER CONNECTIONS WITH PUMP P3

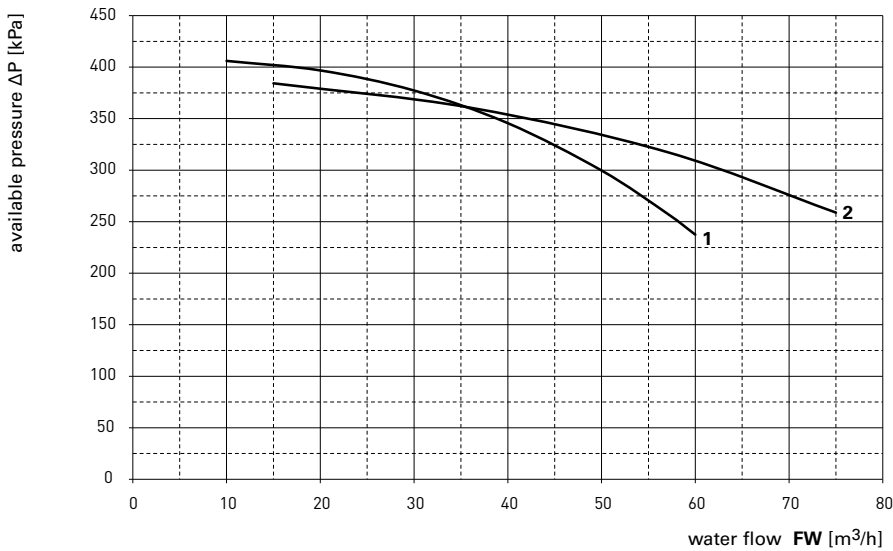

1: iASN 075- 100
2: iASN 110- 150

EVAPORATOR PRESSURE DROPS (MWT)

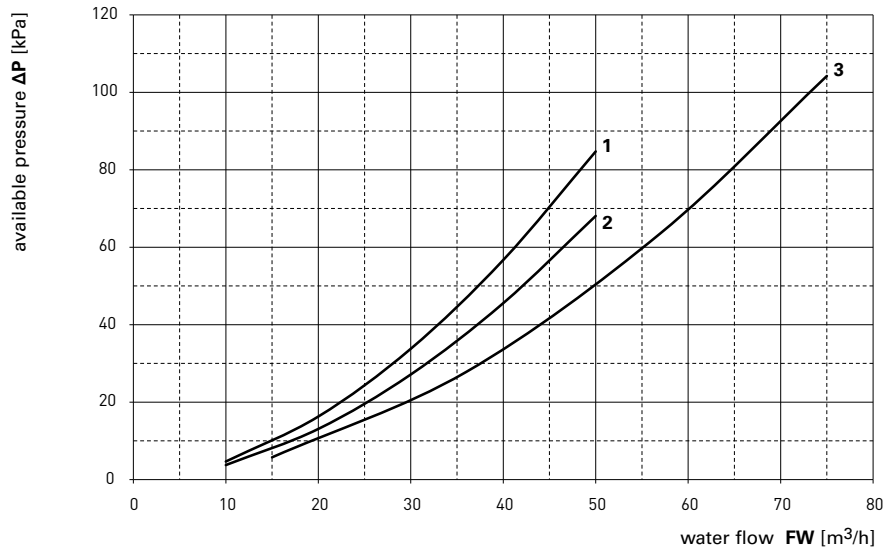

- 1: iASN 075
- 2: iASN 100
- 3: iASN 110-150

AVAILABLE PRESSURE AT CHILLER CONNECTIONS WITH PUMP P2 (MWT)

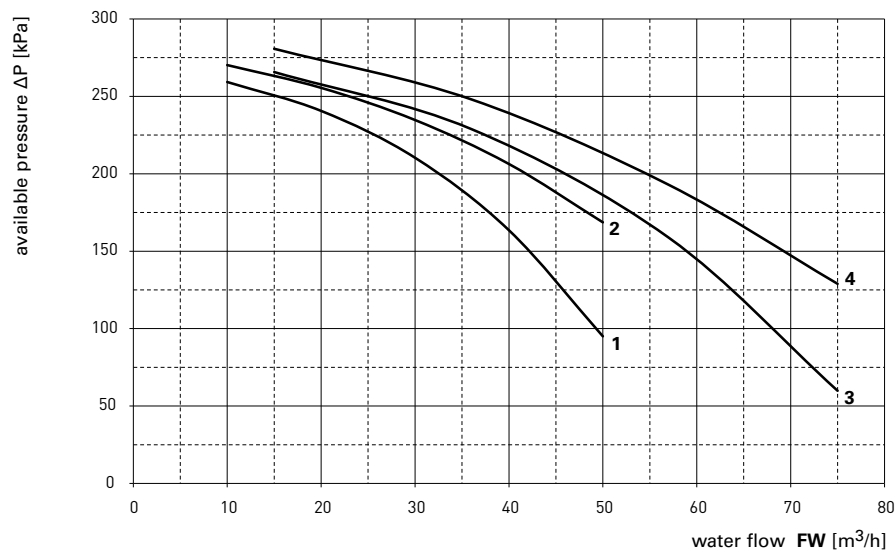

- 1: iASN 075
- 2: iASN 100
- 3: iASN 110
- 4: iASN 150

AVAILABLE PRESSURE AT CHILLER CONNECTIONS WITH PUMP P3 (MWT)

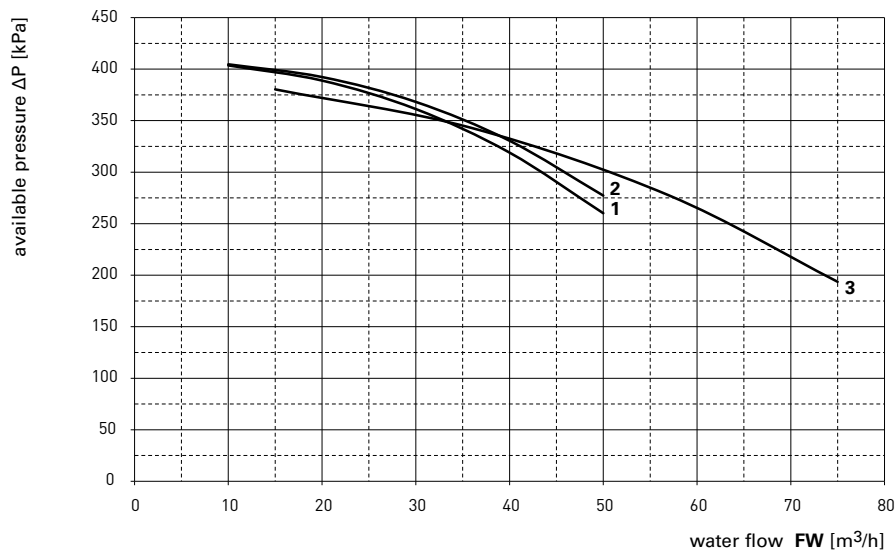

- 1: iASN 075
- 2: iASN 100
- 3: iASN 110-150

WORKING LIMITS AND CORRECTION FACTORS

WORKING LIMITS

		Min	Max
		HE/SHE	HE/SHE
External air temperature	STD	-10 (1)	45
	Low ambient temperature option	-20	45
Evaporator inlet water temperature (2)	°C	4 (*) / -6 (**)	25 (*) / 4 (*)
Evaporator outlet water temperature	°C	0 (*) / -10 (**)	20 (*) / 0 (*)
Water delta T	°C	4	10
Pressure in the hydraulic circuit without integrated hydronic module	barg	0	6
Pressure in the hydraulic circuit with pump/s (no storage tank)	barg	0	6
Pressure in the hydraulic circuit with storage tank and pump/s	barg	0	3

(1) See performance data table.

(2) Comply with the exchangers minimum and maximum flow rate values.

(*) For water outlet temperatures lower than 6 °C you must add a suitable quantity of anti-freeze additives.

(**) MWT configuration.

SOLUTIONS OF WATER AND ETHYLENE GLYCOL

		% Ethylene glycol by weight					
		0	10	20	30	40	50
Freezing temperature	(°C)	0	-3,7	-8,7	-15,3	-23,5	-35,6
Cooling capacity correction factor (kW)	K1	1	0,988	0,972	0,954	0,933	0,908
Absorbed power correction factor (kW)	Kp1	1	0,999	0,998	0,996	0,994	0,991
Water flow correction factor ⁽¹⁾ (m ³ /h)	K _{FWE1}	1	1,020	1,042	1,064	1,087	1,111
Pressure drop correction factor (kPa)	Kdp1	1	1,128	1,267	1,417	1,580	1,755

Multiply the unit performances by the correction factors given in the table. (es. Pf (new) = Pf x K1).

(1) K_{FWE1} = Correction factor (referred to the cooling capacity corrected by K1) to obtain the water flow with a ΔT of 5 °C.

FOULING FACTORS

		Evaporator fouling factor (m ² °C/W)				
		0	0,000043	0,000086	0,000172	0,000344
Cooling capacity correction factor	K2	1	0,988	0,977	0,955	0,914
Absorbed power correction factor	Kp2	1	0,996	0,993	0,986	0,974

To determine the effect of fouling on the evaporator or in the partial heat recovery, multiply the Pf by K2 and the absorbed power Pa by Kp2.

(es. Pf(new) = Pf x K2, Pa(new) = Pa x Kp2).

CONDENSER CORRECTION FACTORS

		Altitude (m)				
		0	500	1000	1500	2000
Cooling capacity correction factor	K3	1	0,990	0,980	0,977	0,972
Absorbed power correction factor	Kp3	1	1,005	1,012	1,018	1,027
Reduction of the max. / min. external air temperature (*)	Kt3 (°C)	0	0,6	1,1	1,8	2,5

Multiply the unit performances by the correction factors given in the table. (Pf(new) = Pf x K3, Pa(new) = Pa x Kp3. (*) To obtain the maximum (minimum) external air temperature, subtract (add) the values indicated from (to) the maximum (minimum) external air temperature in the performance data table (Ta (new) = Ta - (+) Kt3).

ΔT ≠ 5 °C CORRECTION FACTORS

		ΔT						
		4	5	6	7	8	9	10
Cooling capacity correction factor	K4	0,992	1	1,007	1,013	1,019	1,025	1,031
Absorbed power correction factor	Kp4	1,005	1	0,999	0,998	0,999	0,999	1,000

Multiply the unit performance by the correction factors given in table (P* = P₋ x K4, Pa* = Pa x Kp4 dove P₋ = Pf). The new water flow to the evaporator is calculated by means of the following equation Fw (l/h) = P* (kW) x 860 / ΔT where ΔT is the delta T of the water through the evaporator (°C).

OVERALL DIMENSIONS (Basic version without hydronic module and without buffer tank)

iASN - 075

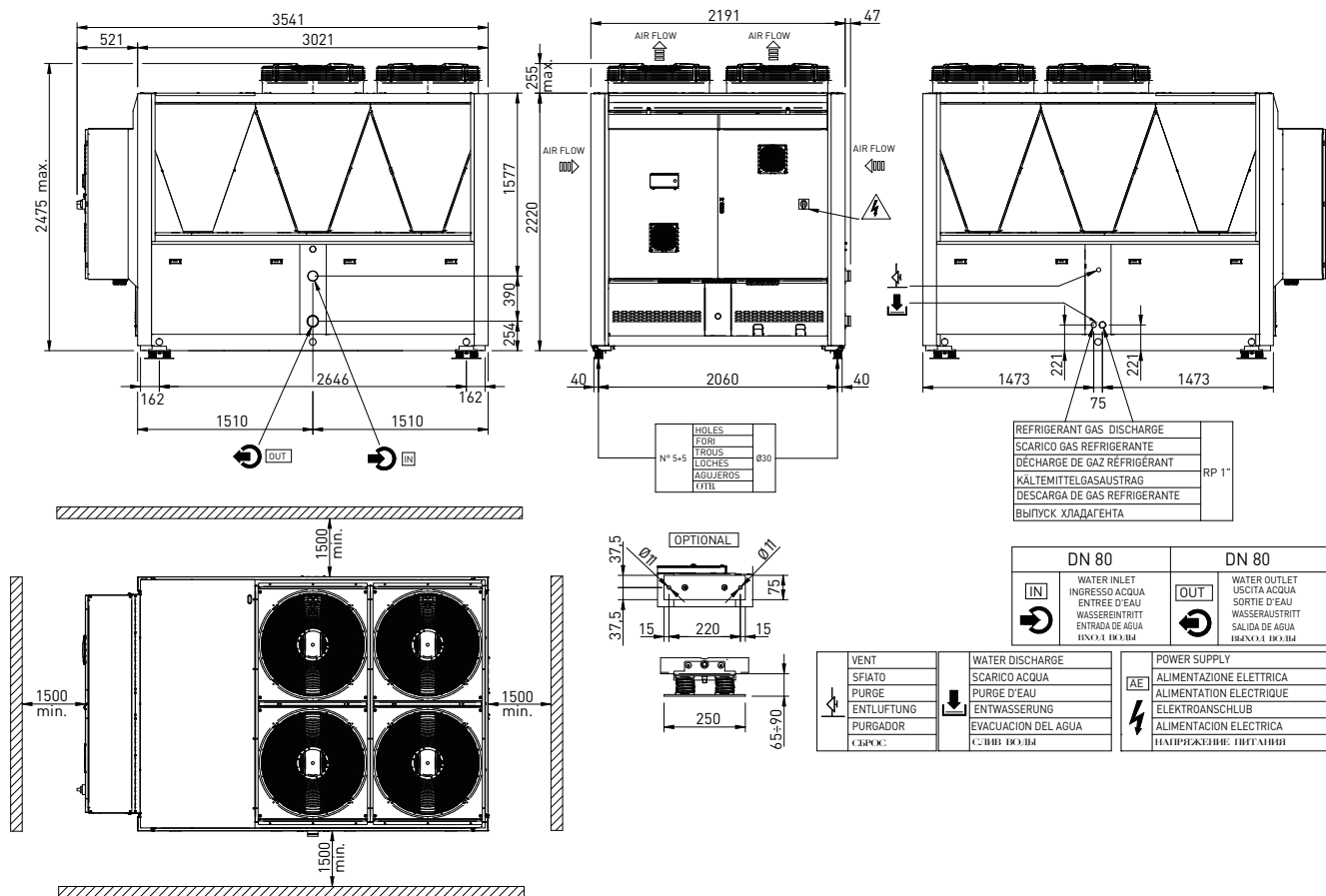

iASN - 100

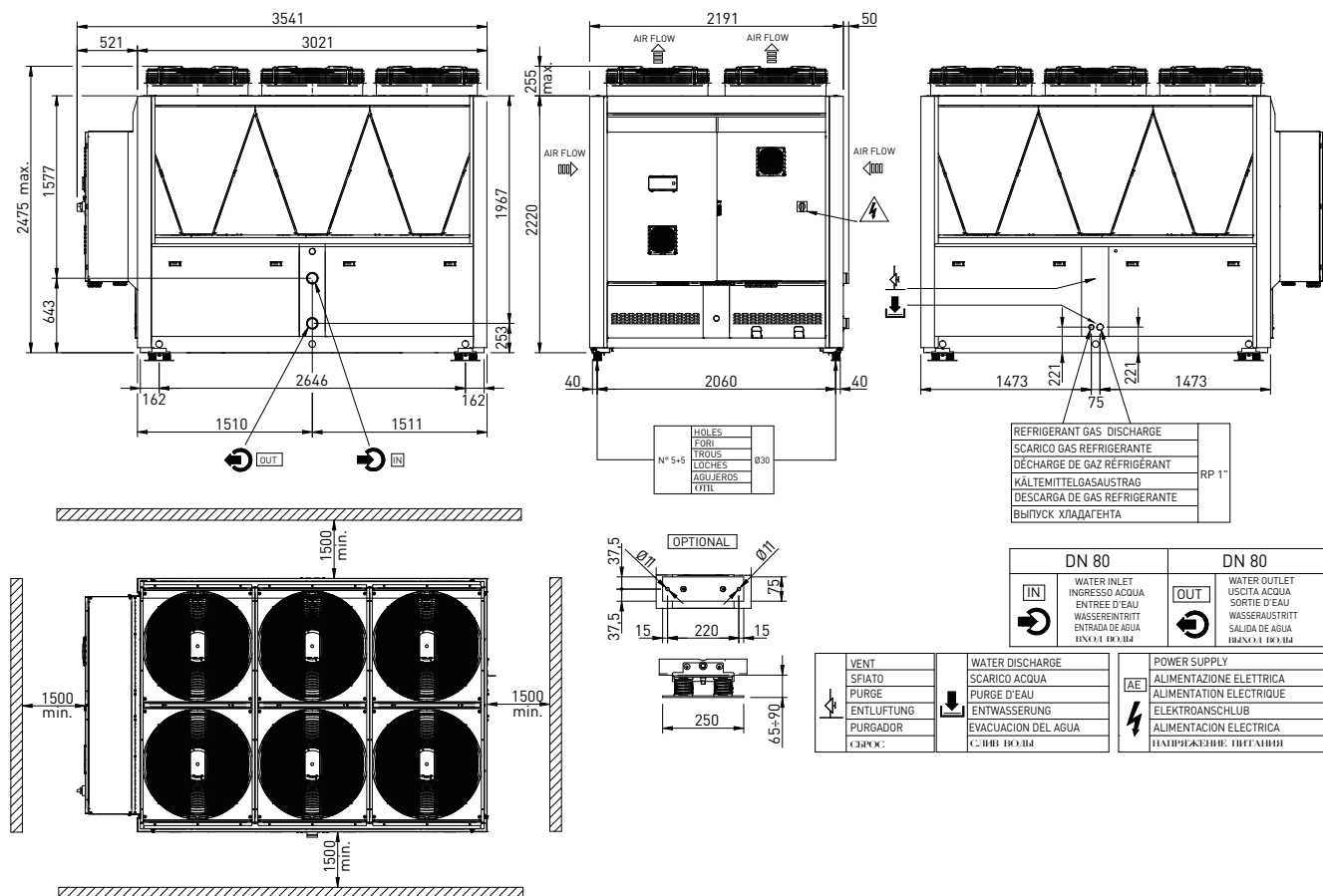

iASN - 110

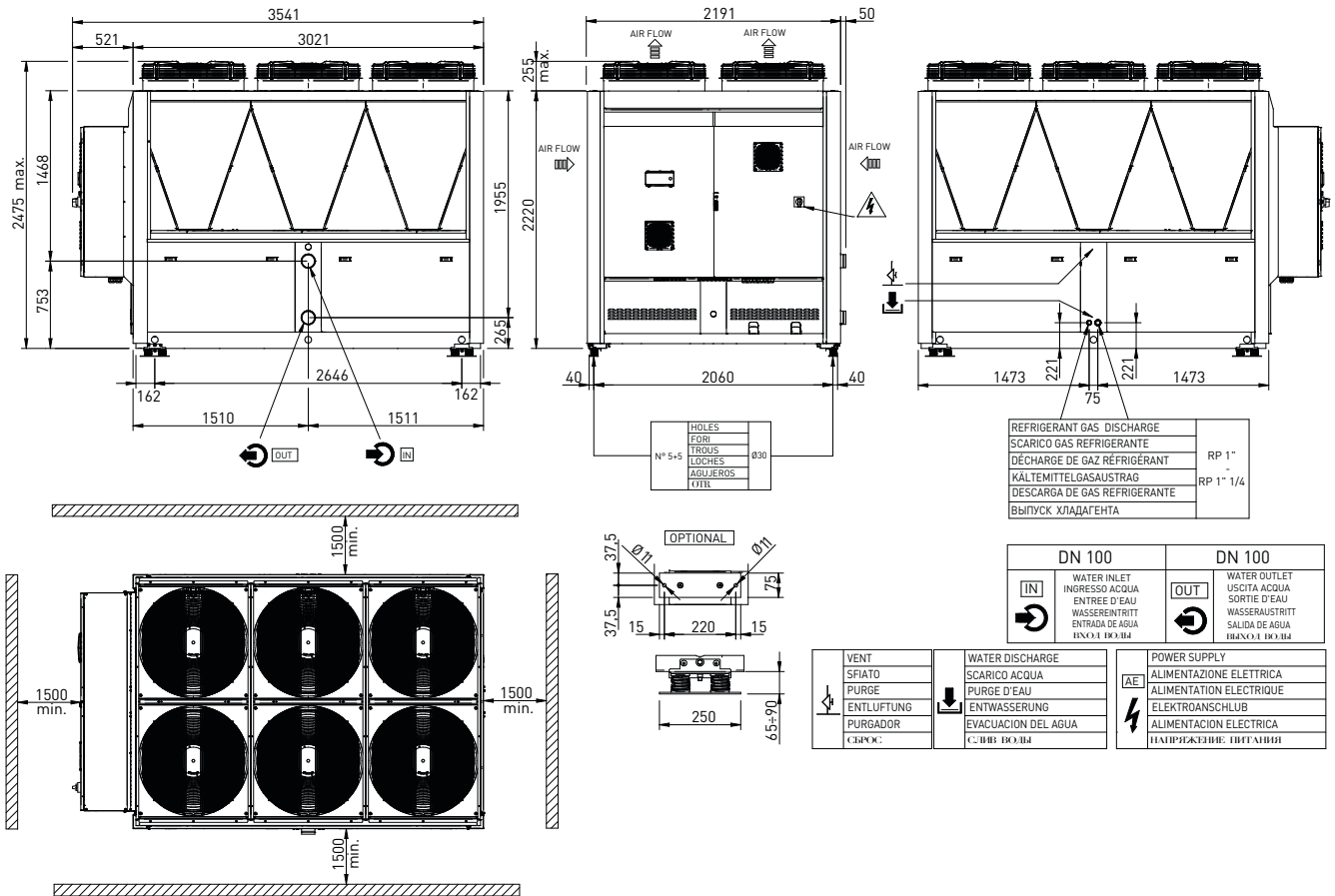

iASN - 150

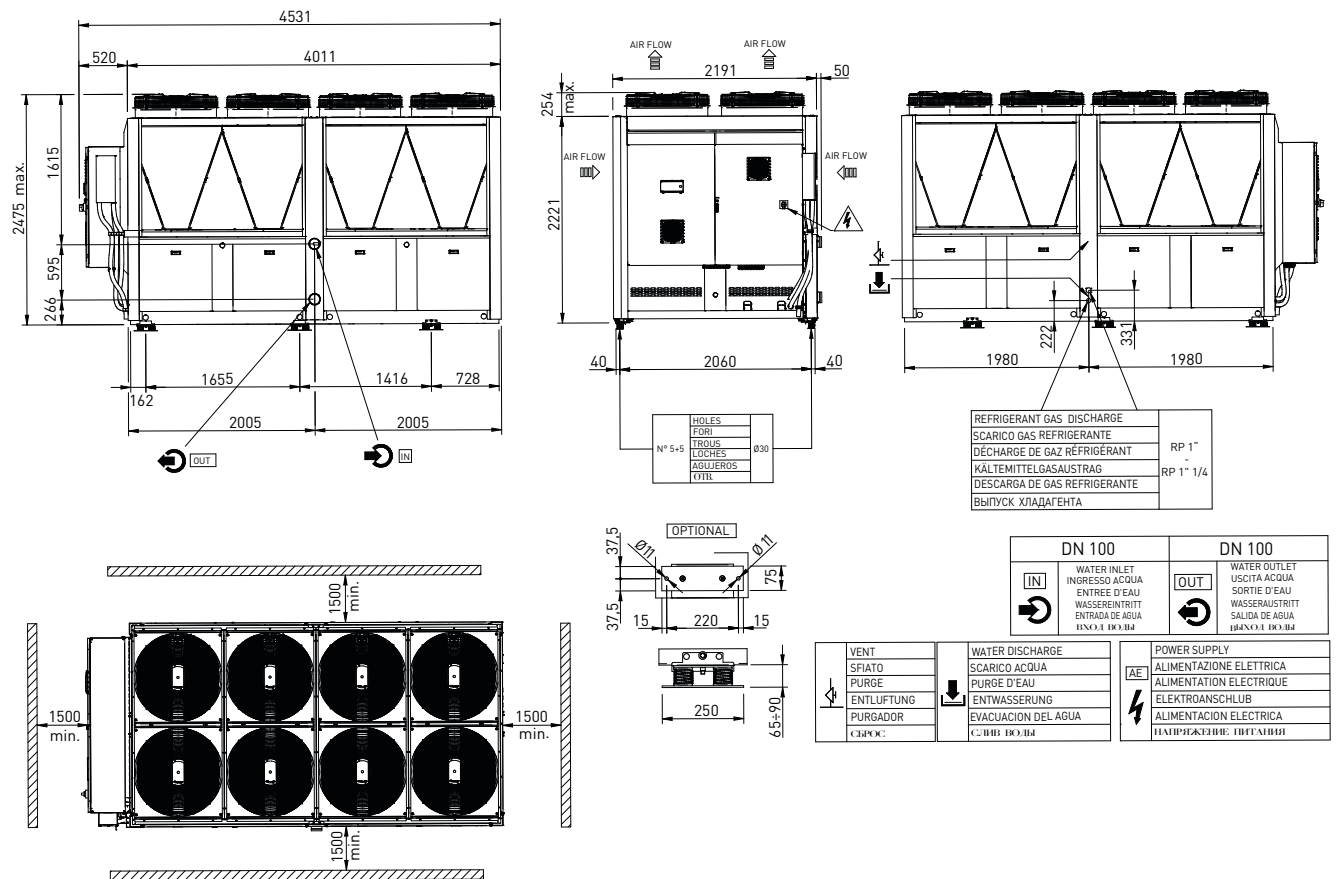

INSTALLATION GUIDE

The installation of the ARIES N units must comply with the following:

- a) Install the unit in a proper horizontal position to ensure a correct oil return to the compressors.
- b) Maintain the specified clearances around the unit as indicated in the overall dimensions.
- c) Where possible, install the units in a way to minimise the effects of noise, vibration, etc. Don't install the unit in areas where the noise can cause a discomfort. The vibrations transmitted to the ground must be reduced by using anti-vibration mounts, flexible joints on the water pipelines and on the conduit containing the cable of electrical supply.
- d) Electrical installation procedures must be carried out by a specialist in accordance with the wiring diagrams and in compliance with the current regulations in force in the country where the unit is installed.
- e) Typical hydraulic connection system:
 1. "Victaulic" connections
 2. Temperature probe
 3. Pressure gauge
 4. Air bleed valve
 5. Discharge valve
 6. Anti-vibration coupling
 7. Shut-off valve
 8. Filter with removable filter basket

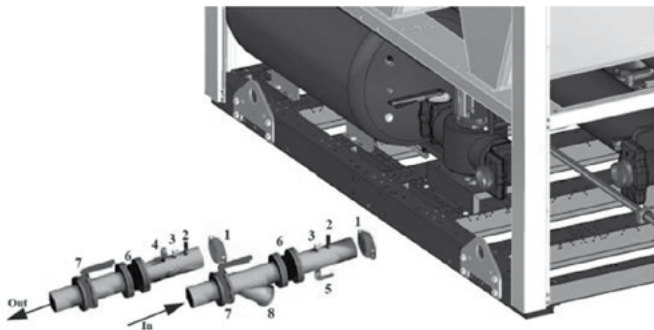

- f) Install a metal filter with a mesh of 0,4 mm at least on the water inlet pipeline to the evaporator and condenser. Failure to observe this prescription can result in irreparable damage to the evaporator or condenser.
- g) In case of cooling capacity greater than the maximum available with a single unit, the unit hydraulic system can be connected in parallel. To avoid water flow imbalance, it's recommended to select the same unit model.
- h) In case of water flow greater or lesser than the maximum or minimum allowable by the chiller, it's necessary to fit a by-pass between the inlet and outlet hydraulic connections.
- i) It's recommended to vent properly all air in the hydraulic system. A small quantity of air can cause freezing phenomena in the evaporator.

j) Install suitable wind screens protecting the condensing coils if the chiller is required to operate with ambient temperatures below 0 °C and if it is envisaged that the unit could be subject to wind velocities more than 2 m/s.

k) Install a water storage tank if necessary; the storage tank reduce the fluctuations extent of chilled water temperature (delta T) while simultaneously optimising the energy efficiency of the unit. The total volume of the hydraulic inertia depends on the maximum acceptable value in terms of chilled water delta T. The values shown in the following table are referred to the minimum volume necessary to ensure the correct unit operation:

	iASN 075	iASN 100	iASN 110	iASN 150
Minimum volume [m ³]	0,80	0,80	0,80	1,10

l) When the installation involves two or more units positioned close together on the long side it's necessary to ensure a minimum distance between the condensing coils. In this case the minimum distances to be assumed is twice as much as indicated in the clearances (see the overall dimensions).

m) During shutdown in winter, the hydraulic system must be discharged, or anti-freeze additives must be considered alternatively.

n) The fluids used in the evaporators and condensers must comply with the following features and limits:

Water component for corrosion limit on Copper	
Element/compound/property	Value/Unit
pH	7.5 – 9.0
Conductivity	< 500 µS/cm
Total Hardness	4.5 – 8.5 dH°
Free Chlorine	< 1,0 ppm
Ammonia (NH ₃)	< 0.5 ppm
Sulphate (SO ₄ ²⁻)	< 100 ppm
Hydrogen carbonate (HCO ₃ ⁻)	60 – 200 ppm
(HCO ₃ ⁻) / (SO ₄ ²⁻)	> 1.5
(Ca + Mg) / (HCO ₃ ⁻)	> 0.5
Chloride (Cl ⁻)	<50 ppm
PO ₄ ³⁻	<2.0 ppm
Fe ³⁺	<0.5 ppm
Mn ⁺⁺	<0.05 ppm
CO ₂	<50 ppm
H ₂ S	<50 ppb
Temperature	<65 °C
Oxygen content	<0.1 ppm

o) The hydraulic pump/s operation must be avoided in the absence of water even at start-up.

p) The unit must be install outdoors taking care to prevent any refrigerant leak can flowing inside the buildings or in any case endangering people and property. In case of a leak, the refrigerant tends to stratify with downwards accumulation. It's important to place the unit so that the refrigerant doesn't flow inside any ventilation duct, entrance doors, hatches, manholes or similar openings.

q) In case of a heat exchanger failure, any refrigerant leakage may contaminate the hydraulic circuit of the unit and to be released inside the building. For this reason, is important to pay attention during the hydraulic circuit design. In particular, the safety valves and automatic air vents must be installed outside the building. If not possible, is necessary to convey the discharges of safety valves and automatic air vents to the external environment. The unit must be installed in a place exclusively accessible to authorized personnel only.

r) During the installation procedures, the end user will need to conduct a risk assessment in collaboration with a local notified body in compliance with the local rules and regulations in force. The responsibility of the completed risk assessment required for the proper installation and the correct functioning of the unit-plant assembly is at end user care.

Specifically:

- the unit must be installed outdoor and in areas that don't affect to the natural ventilation, in full compliance with the EN378 standards and in accordance with all indications contained within the user manual (also called IOM);
- the end user (operator) is responsible for the system on the installation site;
- the ordinary and extraordinary maintenance operations must be carried out by qualified personnel who have been specifically certified and authorized to handle A3 refrigerants.

s) The chiller(s) must be installed in safe places, free of areas with potentially explosive atmospheres. The chiller(s) must be connected to electrical systems designed according to current standards, in areas compliant with the standards imposed by the Fire Brigade and in environments compliant with local building standards. Within the potentially explosive areas generated by the machine, also taking into account the national regulations of the country of use, it is necessary to:

- Do not install equipment that is unsuitable for use in these potentially explosive zones (the minimum requirements of the equipment are: 3G IIB T4);
- Avoid naked flames, sparks and hot works;
- Avoid the presence of sources of ignition due to processes that may generate remote triggers (ionising and non-ionising radiation);
- Avoid the direct and indirect effects of lightning;
- Avoid electrostatic charges;
- Avoid interference with potentially hazardous elements such as drains, openings in the earth, basements, power lines, stores of flammable substances, railways, motorways etc.

As the refrigerant gas used is heavier than air, even a small gas leak, which in itself is not dangerous, can cause a build-up of gas if it infiltrates into underground areas, forming pockets.

A suitable "safety" distance should be assured also for chilling systems installed outdoors, in order to minimise the risk that flammable concentrations enter premises occupied by humans (e.g. through windows, ventilation openings, where people meet outdoors, etc.). However, external wind speeds tend to be quite high (compared to indoor environments) even when the air seems "still", so also the amount of flammable mixture should be adjusted to consider the additional dispersion caused by the surrounding air.

NOTE: A more comprehensive Installation Guidance can be found in the available iASN/ASN 075-150 Installation, Operating and Maintenance (IOM) manual. For the latest IOM please visit our iASN product page at www.trane.eu or contact our local Sales Office.

Trane - by Trane Technologies (NYSE:TT), a global innovator - creates comfortable, energy efficient indoor environments for commercial and residential applications.
For more information please visit www.trane.eu or www.tranetechnologies.com

Trane has a policy of continuous product and product data improvements and reserves the right to change design and specifications without notice.
We are committed to using environmentally conscious print practices.

CG-PRC060D-GB May 2024
Supersedes CG-PRC060C-GB April 2024

©2024 Trane

Confidential and proprietary Trane information