



Installation Operation Maintenance

CCUF

Indoor condenserless chillers with scroll compressors and
R410A refrigerant

Cooling capacity 45 - 620 kW

October 2023

CG-SVX050E-GB

Original instructions

TRANE
TECHNOLOGIES



INDEX

| | | |
|----|--------------------------------------------------------------|----|
| 1 | OVERVIEW..... | 3 |
| 2 | SAFETY REGULATIONS | 3 |
| 3 | OPERATING LIMITS | 8 |
| 4 | INSTALLATION..... | 10 |
| 5 | ACOUSTIC PROTECTION | 15 |
| 6 | ELECTRICAL POWER SUPPLY | 15 |
| 7 | WATER CONNECTIONS..... | 17 |
| 8 | REFRIGERANT SCHEME | 32 |
| 9 | CONNECTION TO THE REMOTE CONDENSER..... | 33 |
| 10 | ELECTRICAL PANEL AND ELECTRICAL DATA..... | 34 |
| 11 | OPERATOR RESPONSABILITIES | 37 |
| 12 | START-UP PRELIMINARY PROCEDURES | 37 |
| 13 | CHECK LIST – MANDATORY OPERATION CONTROL BEFORE START-UP ... | 38 |
| 14 | START-UP..... | 44 |
| 15 | MAINTENANCE..... | 45 |
| 16 | RECOMMENDED SPARE PARTS..... | 49 |
| 17 | TROUBLESHOOTING..... | 50 |
| 18 | IMPROPER USES..... | 53 |

1 OVERVIEW

FOREWARD

These instructions are given as a guide to good practice in the installation, start-up, operation, and maintenance by the contractor or end-user of CCUF units. It does not contain full service procedures necessary for the continued successful operation of this equipment. The services of a qualified technician should be employed through the medium of a maintenance contract with a reputable service company. Read this manual thoroughly before unit start-up.

1.1 WARRANTY

Warranty is based on the general terms and conditions of the manufacturer. The warranty is void if the equipment is repaired or modified without the written approval of the manufacturer, if the operating limits are exceeded or if the control system or the electrical wiring is modified. Damage due to misuse, lack of maintenance or failure to comply with the manufacturer's instructions or recommendations is not covered by the warranty obligation. If the user does not conform to the rules of this manual, it may entail cancellation of warranty and liabilities by the manufacturer.

1.3 RECEPTION OF THE UNIT

On arrival, inspect the unit before signing the delivery note. Specify any visible damage on the delivery note and send a registered letter of protest to the last carrier of the goods within 7 days of delivery. Notify the local TRANE Sales office at the same time. The delivery note must be clearly signed and countersigned by the driver.

Any concealed damage shall be notified by a registered letter of protest to the last carrier of the goods within 7 days of delivery. Notify the local TRANE sales office at the same time.

Important notice: No shipping claims will be accepted by TRANE if the above-mentioned procedure is not respected. For more information, refer to the general sales conditions of your local TRANE sales office.

2 SAFETY REGULATIONS

All units are designed, built and inspected in compliance with Pressure Equipment Directive (PED97/23/EC or 2014/68/EU and EU Directive 2006/42/EC).

To avoid death, injury, equipment or property damages the following recommendations should be respected during maintenance and the service visits:

1. The maximum allowable pressures for system leak testing on low and high pressure side are given in the chapter "Installation".

Insure to do not exceed test pressure by using appropriate device

2. Disconnect all power supplies before any servicing on the unit

3. Service work on the refrigeration system and electrical system should be carried out by qualified and experienced personnel

4. To avoid any risk, place the unit in an area or technical room with restricted access

2.1 DEFINITIONS

Owner:

The legal representative of the company, body or natural person who owns the plant in which the Trane CCUF unit is installed is responsible for the control and respect of all the safety regulations indicated in this manual as well as the national ones in force.

Installer:

The legal representative of the company appointed by the owner to position and hydraulically, electrically etc. connect the Trane unit to the plant is responsible for moving and the correct installation of the unit in accordance with the indications in this manual and with the national regulations in force.

Operator:

A person authorized by the owner to carry out all the operations of regulation and control on the Trane unit which are specifically mentioned in this manual. He or she should keep to actions described in the manual and limit his or her action to what is explicitly allowed.

Technician:

A person who is directly authorized by Trane or, secondarily, for all EU countries except for Italy, by the distributor of the Trane product, under their own responsibility, to carry out all ordinary or extraordinary maintenance operations, as well as regulations, controls, repairs and parts replacement which may be necessary during the lifetime of the unit.

2.2 ACCESS TO DANGEROUS AREA

The access to the unit dangerous areas is usually obstructed through protection panels, which are removable, by using a tool.

For all the units which allow access to the cooling piping without security gratings (optional) or closing panelling, the following precautions must be taken:

-mark the areas with contact risks.

-apply warning signs.

The danger zone must be of a suitable size to avoid any contact, even accidental contact.

Trane declines any responsibility for damage to things and unauthorized personnel in case of absence of clear and static limiting systems of the risk areas and of the relevant warning and danger signs.

2.3 GENERAL PRECAUTIONS

The operator must only intervene on the unit commands; he or she must not open any panels except for the one which gives access to the command module.

The installer must only intervene on the connections between the plant and the machine; he or she must not open any machine panels nor carry out any commands.

The following precautions should be made when approaching or working on the unit:

- Do not wear jewelry, baggy clothes or any other accessory which can get caught up.
- Use appropriate protection (gloves, glasses etc.) when using an open flame (welding) or compressed air.
- If the unit is located in a closed environment, wear hearing protection.
- Before disconnecting, removing tubes, filters, joints or other line parts intercept the connection tubes, empty them until the pressure reaches that of the atmosphere.
- Do not use your hands to check for possible pressure losses.
- Always use tools which are in good condition; make sure the instructions are fully understood before using them.
- Make sure that any tools, electrical cables or other loose objects are removed before closing the unit and starting it up again.

2.4 PRECAUTIONS AGAINST RISKS DUE TO THE REFRIGERANT

| Safety data | |
|-------------------------------------------------------------------|--------------------------------------------------------------------------------------------------------------------------------------------------------------------------------------------------------------------------------------------------------------------------------------------------------------------------------------------------------------------------------------------------------------------------------------------------------------------------------------------------------------------------------------------------------------------------------------------------------------------------------|
| Toxicity | Not important |
| Risks for skin touching | Splashes or sprinkles can cause chill burns. The risk of absorptions through the skin is not relevant. The R410a refrigerant could take some lightly irritating effects and in liquid stage it has a strong skinning effect. In this case it is necessary to rinse with fresh water the contaminated parts of the skin The refrigerant in liquid stage in contact with wet fabrics cause freezing and adherence to the skin. In this case it is necessary to put off the contaminated clothes to avoid freezing. Please contact a doctor in case of irritation of the contaminated parts. |
| Risks for contact with the eyes | chargeors don't take any effect. Splashes or sprinklers can cause chill burns. In those cases it is necessary to rinse the eyes with water or with solution for ocular washings for 10 minutes. The intervention of a doctor is needed. |
| Risks for ingestion | Should it happen, it causes chill burns. It does not cause vomiting. The person must be kept awake. It is needed to rinse the mouth with fresh water and to drink almost 0.25 liters. The intervention of a doctor is needed. |
| Risks for inhalation | High concentration of vapors in air can lead to anesthetic effects up to a loss of conscience. Long exposures could give rise to cardiac arrhythmia and sometimes even to death. High concentrations can create a reduction of oxygen in air, with consequent possibility of suffocation. Should it happen the person must be taken to the open air and let him take a rest. Administer oxygen if needed. In case the breathing has interrupted or become irregular, it is necessary to apply the artificial breathing. In case of cardiac arrest a heart massage must be applied. Contact a doctor immediately. |
| Conditions to avoid | Use in presence of exposed flames, and of high levels of humidity. |
| Dangerous reactions | Possibility of violent reactions with the sodium, the potassium, the barium and with other alkaline substances, incompatible materials and all the alloys containing more than 2% of magnesium. |
| Protection wearing - Behavior in case of losses or escapes | Wear protection apparel and self-rescuer respirators. Insulate the source of the loss, if this operation can be done in safety conditions. Small quantitative of refrigerant escaped at liquid state can be allowed to evaporate only if the room is well ventilated. In case of great losses ventilate the room immediately. Plug the loss with sand, soil or other absorbent material; avoid that the liquid refrigerant can enter in water-drainages or losing pools. |

**po
Dismantlement**

The best procedure is the recovery and the recycle. If this is not possible the refrigerant must be conferred to an accredited system for its destruction in order to neutralize acid and toxic by-products.

2.5 PRECAUTIONS AGAINST RESIDUAL RISKS

Prevention from risks due to the command system

- make sure the instructions for use have been understood before carrying out any work on the control panel.
- always keep the instruction manual close at hand when working on the control panel.
- start up the unit only after having certified that it is correctly connected to the plant.
- inform the technician promptly of any alarms which appear on the unit.
- do not reset the alarms to manual restart without having first identified the cause and removed it.

2.6 PREVENTION AGAINST RESIDUAL MECHANICAL RISKS

- install the unit in accordance with the provisions of the following manual.
- carry out all the maintenance operations provided for by this manual regularly.
- wear a protective helmet before entering inside the unit.
- before opening a machine panel make sure that it is firmly connected by means of a hinge.
- do not touch the air condensation batteries without having first put on protective gloves.
- do not remove the protections to the moving parts while the unit is running.
- before restarting the unit make sure that the moving part protections are in the correct position.

2.7 PREVENTION AGAINST RESIDUAL ELECTRICAL RISKS

- connect the unit to the mains in accordance with the provisions of this manual.
 - carry out all maintenance operations regularly.
 - before opening the control panel disconnect the unit from the mains by means of the external knife switch.
- before opening the control panel disconnect the unit from the mains by means of the external knife switch.

It must be taken into account especially that when soft starters instead of contactors are installed as compressors drives, one phase of any compressor remains live when the compressor is off but the main switch is closed. Do not access the compressor electrical box.

- check that the unit has been earthen correctly before starting it up.
- control all the electrical connections and the connection cables paying particular attention to the state of isolation; replace the cables which are clearly worn or damaged.
- carry out periodic checks of the wiring inside the panel.
- do not use cables with an inappropriate section or flying connections not even for a limited period or in an emergency.

2.8 PREVENTION AGAINST RESIDUAL RISKS OF A DIFFERENT NATURE

- the residual risks due to pressure are mainly coming from a failure of the safety devices. To prevent them it is necessary to check and replace them when required
- carry out the plant connections to the unit by following the indications reported on the following manual and on the panels of the unit itself.
- if a part is disassembled, make sure that it is correctly reassembled before restarting the unit.
- do not touch the discharge line of the compressor, the compressor itself or any other tube or component which is inside the machine without putting on protective gloves.
- keep a fire extinguisher which is able to put out fires on electrical equipment near the machine.
- in the event of fire either if it originates on the unit or near it make sure the power supply to the unit is promptly cut and that any person who might be near the unit at that moment is moved to a secure location.
- on units installed inside, connect the refrigerant circuit shut off valve to a network of tubes which are able to lead the possible spillage of refrigerating fluid outside.
- eliminate any fluid loss inside or outside the unit.
- collect the discharge liquid and clean up any possible oil leakage.
- periodically clean the compressor casing of the accumulated dirt deposits.
- do not keep inflammable liquids near the unit.
- do not dispose of the refrigerant fluid and the lubricating oil in the environment.
- welding should only be carried out on empty tubes; do not approach the tubes containing refrigerant fluid with flames or other sources of heat.
- do not bend or strike tubes containing pressurized fluids.

2.9 PRECAUTIONS TO BE OBSERVED DURING MAINTENANCE OPERATIONS

Only authorized technicians may carry out maintenance operations. Before carrying out any maintenance the following must be performed:

- isolate the unit from the mains electricity by using the external knife switch.
- place a notice on the external knife switch which says “do not use - maintenance in progress”.
- make sure that any possible on-off commands are disabled.
- use appropriate safety equipment (helmet, isolating gloves, protective glasses, safety shoes etc.).

If measurements or controls must be carried out which require the machine to be running the following observations must be followed:

- operate with the electrical panel open for as short a time as is possible.
- close the electrical panel as soon as the individual measurement or control has been carried out.
- for units which are located outside, do not carry out interventions in dangerous atmospheric conditions such as rain, snow, fog etc.

The following precautions should also be taken at all times:

- never dispose of fluids contained in the refrigerant circuit into the environment.
- when replacing the electronic card always use appropriate equipment (extractor, anti-static bracelet, etc.).
- if a compressor, the evaporator, or any other heavy part is to be replaced, make sure that the lifting equipment matches the weight to be lifted.
- if the unit has an independent compressor compartment, do not open the ventilator compartment without having first isolated the machine using the knife switch on the side of the panel and only after having placed a sign which says “do not use - maintenance in progress”.
- if modifications must be carried out to the cooling, hydraulic or electrical circuit of the unit, as well as to its command logic, contact Trane.
- if particularly complicated assembly or disassembly operations are to be carried out contact Trane.
- always use original spare parts bought directly from Trane or from official dealers of the companies reported in the list of recommended spare parts.
- if the unit is to be moved after a year of being in the site or if it has to be dismantled contact Trane.

IMPORTANT: No high pressure safety valve is installed on the unit by Trane. The unit fail safe is assured by cut-out of the electrical power supply to the coils of the compressors contactors. The cut-out action is carried out by the electrical contact of the high pressure switch installed on the relevant refrigerant circuit. No Schraeder valve is installed in the service socket the circuit high pressure switch is screwed into. This implies that the replacement of the high pressure switch requires that the relevant refrigerant circuit has been discharged of all the refrigerant inside it.



Figure 1 – Indicative position of the signs warning about the necessity of replacing the high pressure switches with the unit void of refrigerant related to the lack of high pressure safety valves

DO NOT PULL OUT THE HIGH PRESSURE SWITCHES (Nr. 1 PER REFRIGERANT CIRCUIT) IF THE UNIT IS NOT COMPLETELY VOID OF REFRIGERANT. FAILURE TO FOLLOW THIS INSTRUCTION COULD RESULT IN DEATH OR SERIOUS INJURY

2.10 MANUAL ALARM RESET

If there is an alarm the unit must not be manually reset before having located and eliminated the cause of the fault. Repeated manual resets may cause the warranty to be annulled.

3 OPERATING LIMITS

3.1 STORAGE

The units can be stored within the following environmental conditions:

| | | |
|-------------------------|---|---------------------|
| Min ambient temperature | : | -10°C |
| Max ambient temperature | : | 53°C |
| Max relative humidity | : | 95% not condensable |

CAUTION: The storage in a very high humidity space (condensation) can damage electronic components.

CAUTION: CCUF units are intended only for indoor usage and storage.

If they are installed in a machinery room they must be installed within the meaning of the EN 378-3 Standard.

Should the unit be stored outdoor it is customer's duty to implement any device aimed to protect the unit from the harsh weather effects.

3.2 OPERATING LIMITS

CCUF condenser-less units operation is permitted within the limits indicated in the operating map provided in 3.3

CAUTION: The operation outside the limits specified may cause the activation of the protections and disrupt the operation of the unit and, in extreme cases, damage the unit. In case of doubt, consult the factory. The operating limits apply to the unit operating at full load.

3.3 OPERATING RANGE

CCUF

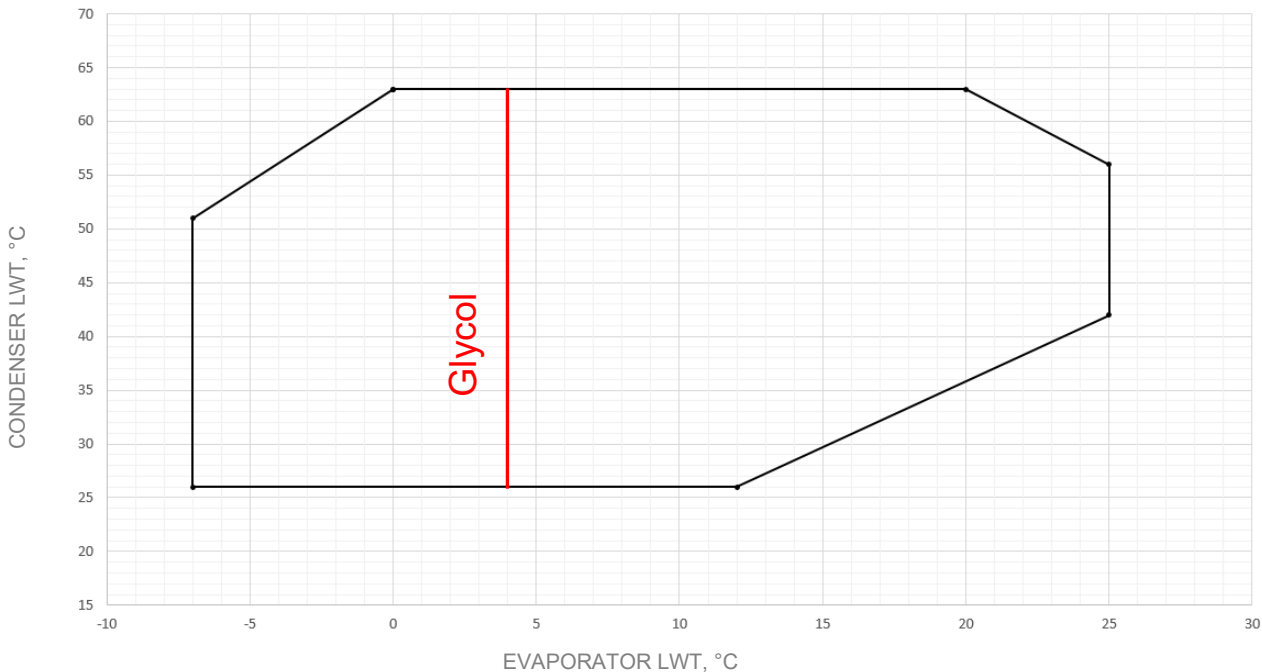

IMPORTANT: A pressure switch cutting directly the power supply to the coils of the compressors contactors prevent refrigerant from reaching dangerously high pressure values. No safety valve is installed on the unit.

ETHYLENE GLYCOL CORRECTION TABLE

| % Ethylene glycol weight | | 10% | 15% | 20% | 25% | 30% | 35% |
|--------------------------------------------------------------|----|------------|------------|------------|------------|------------|------------|
| Lowest outlet water temperature | °C | 4 | 2 | 0 | -2,8 | -6 | -10 |
| Suggested security limit Cooling capacity coefficient | °C | 1 | -1 | -4 | -6 | -10 | -14 |
| Power input coefficient | - | 0,99 | 0,985 | 0,981 | 0,977 | 0,974 | 0,971 |
| Flow rate coefficient | - | 0,993 | 0,99 | 0,988 | 0,986 | 0,984 | 0,982 |
| Pressure drop coefficient | - | 1,04 | 1,05 | 1,07 | 1,08 | 1,09 | 1,11 |
| | - | 1,11 | 1,17 | 1,23 | 1,31 | 1,39 | 1,47 |

In order to calculate performance with glycol solutions multiply main sizes by respective coefficients.

GLYCOL PERCENTAGE DEPENDING ON FREEZINGTEMPERATURE

| Freezing temperature | % glycol according to the freezing temperature | | | | | |
|------------------------------|-------------------------------------------------------|-------------|--------------|--------------|--------------|--------------|
| | 0°C | -5°C | -10°C | -15°C | -20°C | -25°C |
| % Ethylene glycol | 5% | 12% | 20% | 28% | 35% | 40% |
| Flow rate coefficient | 1,02 | 1,04 | 1,07 | 1,09 | 1,11 | 1,13 |

In order to calculate performance with glycol solutions multiply main sizes by respective coefficients.

IMPORTANT:

**An oversized water pump as on board unit pump is required for operation with glycol >25%.
If any doubt please contact your Trane Sales Office**

4 INSTALLATION

4.1 MOVING AND POSITIONING THE UNIT

The units have been designed to be lifted from above by means of eyebolts and holes in the base members. Use retractor bars to keep the lifting wires or chains away from the unit.

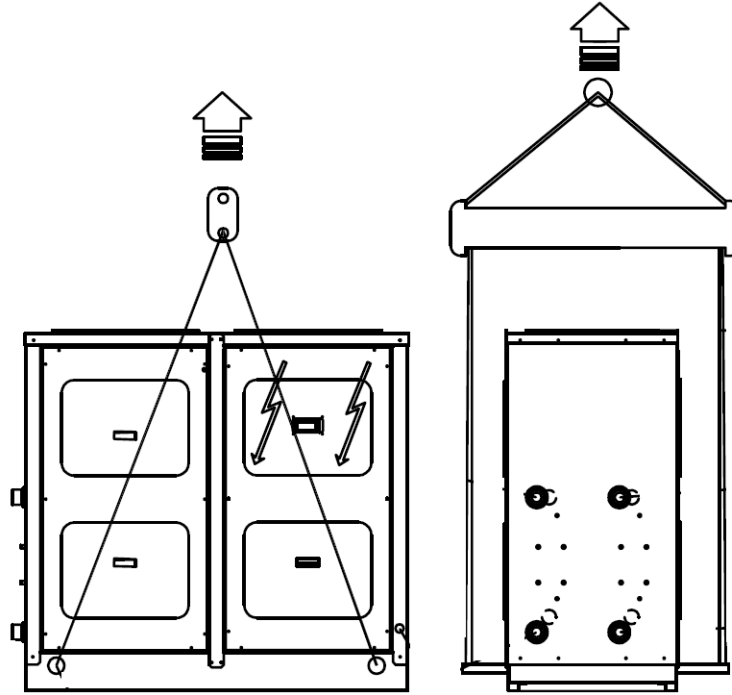

Figure 2 - Correct lifting procedure for platform 1 units (sizes from 013 to 025)

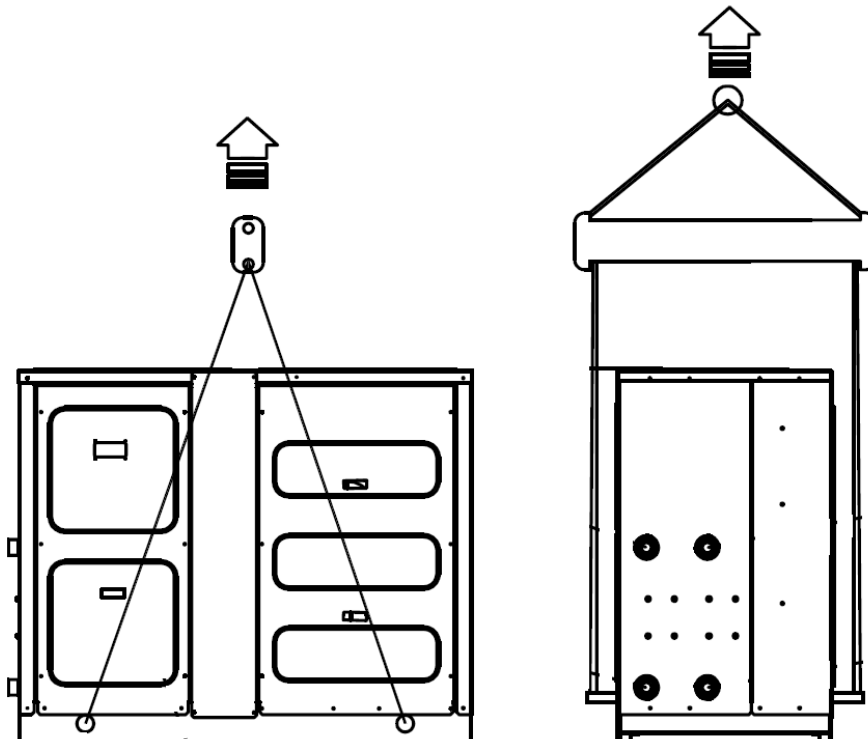

Figure 3 - Correct lifting procedure for platform 2 units (sizes from 029 to 041)

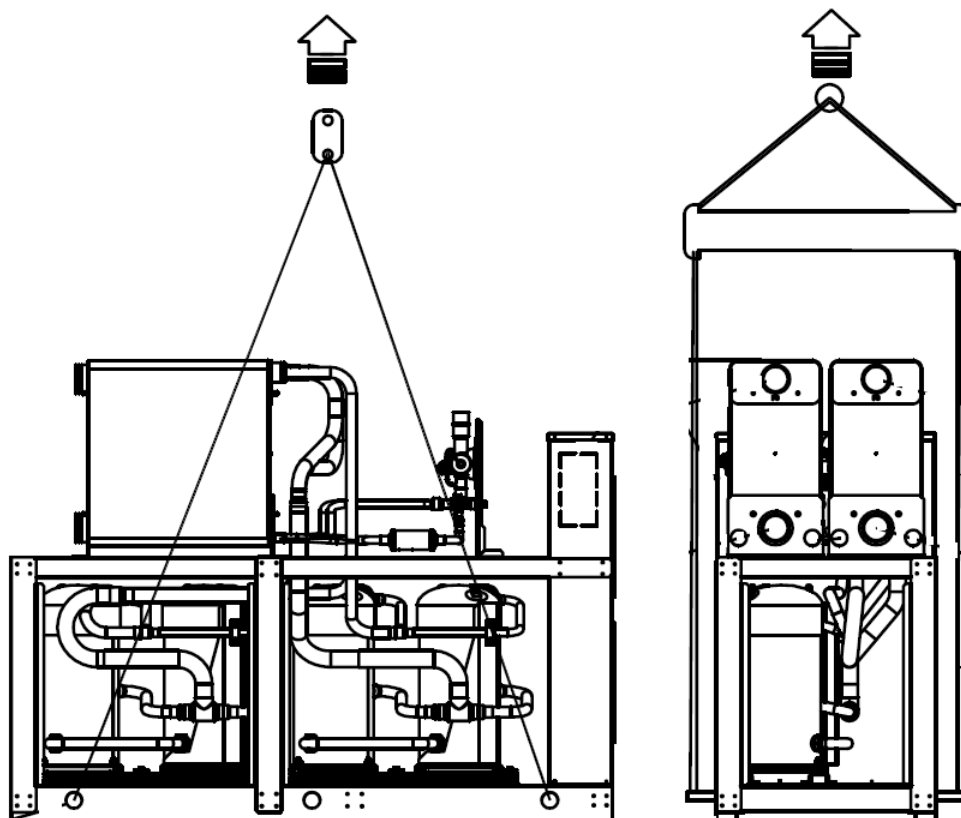

Figure 4 - Correct lifting procedure for platform 3 units (sizes with two refrigerant circuits from 042 to 128)

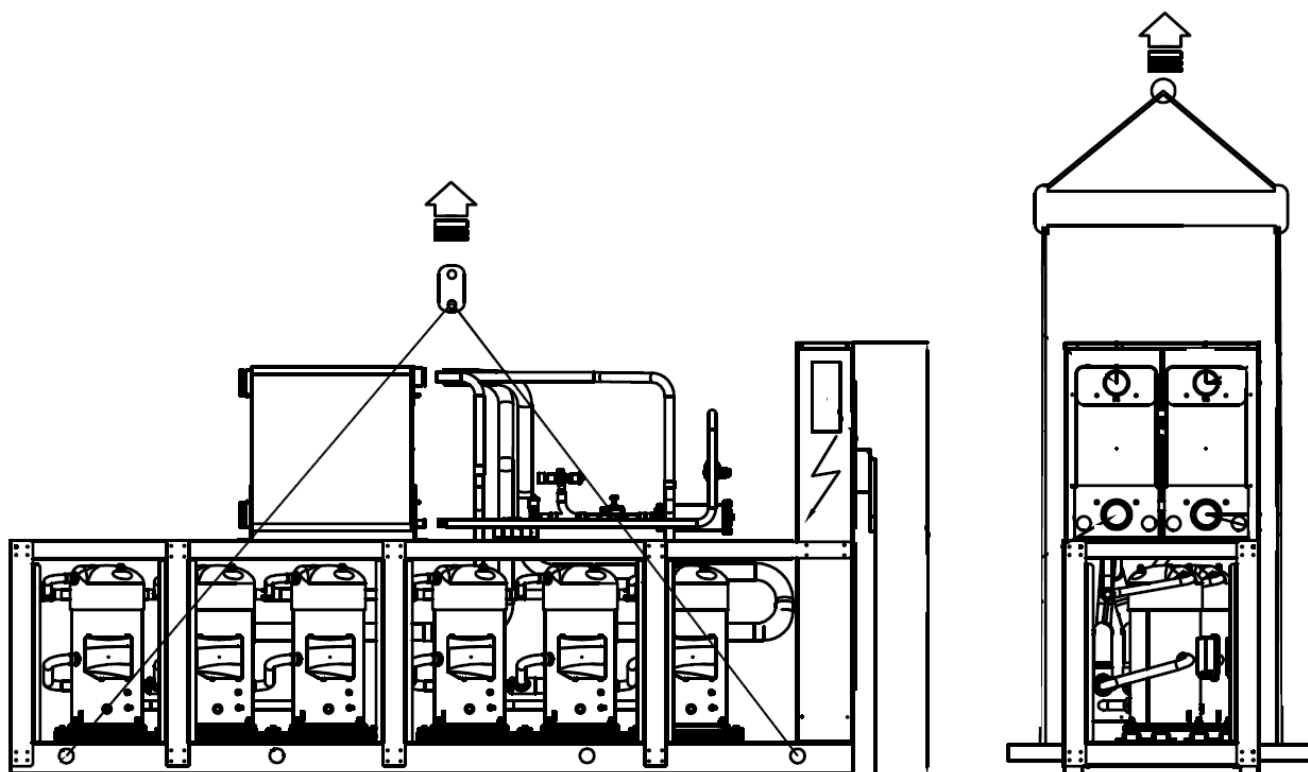

Figure 5 - Correct lifting procedure for platform 4 units (sizes with two refrigerant circuits from 144 to 192)



Lifting procedures provided with the unit have to be respected.

CAUTION

Do not use forklift trucks to lift the unit from below.

If equipment for lifting from above is not available, using rollers may move the unit.

The surface on which the unit is placed must be flat and strong enough to withstand the weight of the unit while running. In order to reduce the transmission of vibrations to the supporting structures, fit shock absorbers in every fastening point. Rubber shock absorbers are recommended for units installed on the ground, spring shock absorbers for units installed on roofs. Open spaces around the unit must be provided for in order to allow normal maintenance to be carried out (as shown on general catalogues).

IMPORTANT: Make sure that during transport the **CCUF** unit ALWAYS remains in the correct position!

For example horizontal positioning of the unit can lead to irreversible damage to the compressors.

Damage arising from incorrect transport will not be under warranty by the manufacturer.

Immediately report an incorrect receipt of goods.

An arrow positioned upward indicates the vertical position of the unit.

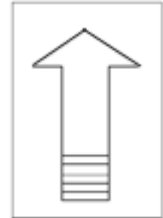

4.2 MINIMUM SPACE REQUIREMENTS

Dimensional drawing shall be respected to avoid:

Difficult maintenance or inaccessibility to components

Limited installation space could reduce the normal air flow, thus significantly reducing the unit performance and considerably increasing consumption of electrical energy.

The following drawings are views from under the units:

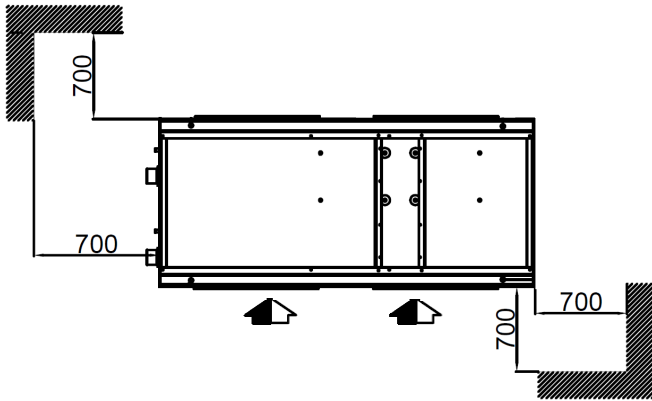

Figure 6 - minimum space requirements [mm] for platform 1 units (sizes from 013 to 025)

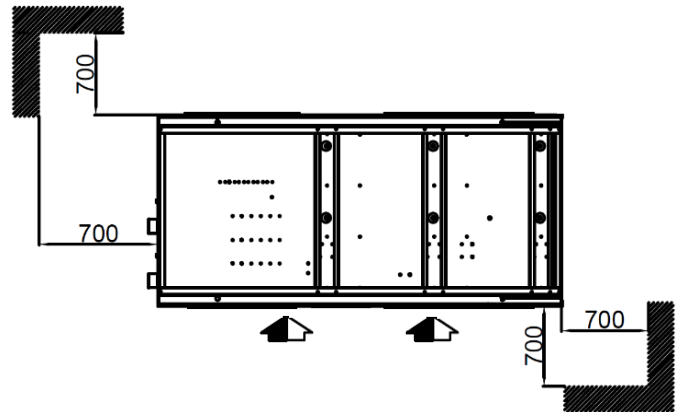

Figure 7 - minimum space requirements [mm] for platform 2 units (sizes from 029 to 041)

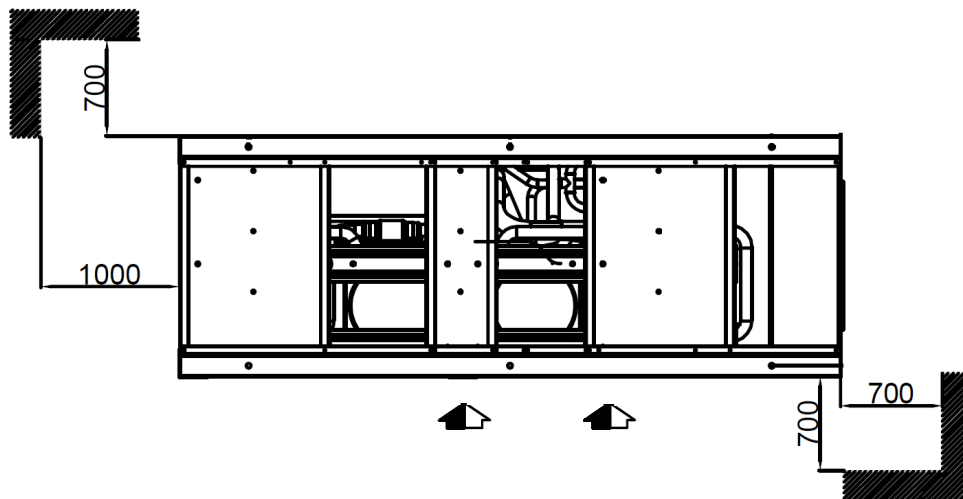

Figure 8 - minimum space requirements [mm] for platform 3 units (sizes from 042 to 128)

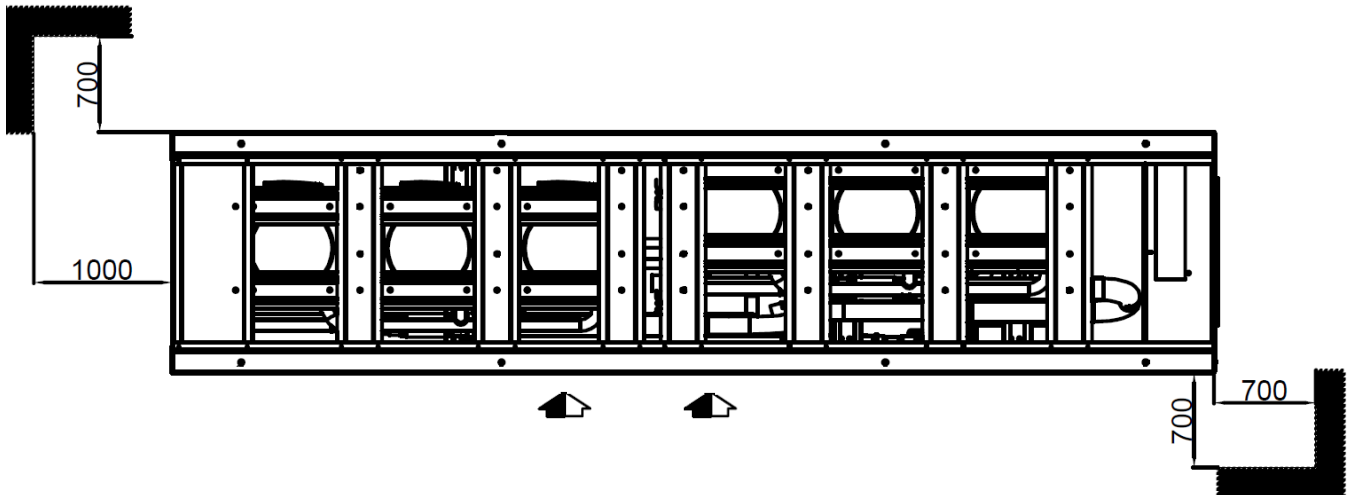

Figure 9 - minimum space requirements
[mm] for platform 4 units (sizes form 144 to
192)



Side of the unit that can be placed next to the wall. This means that with the unit at a distance less than the optimal one of 700 mm the accessibility to some components is worse but in any case is ensured even if the unit is leaning against the wall.

CAUTION: in case two units have to be installed side by side, the distance of respect must be doubled. After the unit has reached the final position, fix the anti-vibration bolts.

4.3 CONTROL OF COMPRESSOR FASTENING

The scroll compressors are fitted on shock absorbers. For fixing through spring anti-vibration mounts, it is necessary to remove blockages put to fasten the compressors, as indicated on the label on compressors body.

5 ACOUSTIC PROTECTION

For maximum isolation effect, water lines and electrical conduit should also be isolated. Wall sleeves and rubber isolated piping hangers can be used to reduce the sound transmitted through water piping. To reduce the sound transmitted through electrical conduit, use flexible electrical conduit. EU and Local codes on sound emissions should always be considered. Since the environment in which a sound source is located affects sound pressure, unit placement must be carefully evaluated. Consult an acoustical engineer for critical connections.

6 ELECTRICAL POWER SUPPLY

The mains power supply characteristics have to match the unit's absorption. The mains power supply tension must correspond to the nominal value $\pm 10\%$, with a maximum difference between the phases of 2%. All power supply wiring must be sized and selected accordingly by the project engineer in accordance with standard IEC 60364. All wiring must comply with local code.

6.1 POWER CONNECTIONS

Protect the unit electric box power supply circuit with protection devices (not included in the supplied equipment). Connect the line terminals with a three-core cable of a section which is appropriate to the machine absorption. The switch and the fuses like all the power connections must comply with the regulations in force.

6.2 IMBALANCE BETWEEN THE SUPPLY TENSION PHASES

Do not run the electrical motors when the voltage unbalance between the phases is more than 2%. Use the following formula to check:

$$\% \text{ Imbalance} = [(V_x - V_{ave}) \times 100 / V_{ave}]$$

$$V_{ave} = (V_1 + V_2 + V_3) / 3$$

V_x = phase with greatest difference from V_{ave} (without regard to the sign)

IMPORTANT: If the mains voltage has an imbalance of above 2%, contact the company, which distributes the electrical energy. If the unit functions with a **unit voltage imbalance between the phases of above 2% the warranty is invalid.**

6.3 UNIT VOLTAGE PHASING

It is important that proper rotation of the compressors be established before the unit is started. Proper motor rotation requires confirmation of the electrical phase sequence of the power supply. The motor is internally connected for clockwise rotation with the incoming power supply phases A-B-C.



6.4 MAIN SWITCHES FEATURES

| <i>Unit size - CCUF</i> | Poli | Ampere | Type |
|-------------------------|-------------|---------------|-------------|
| 013 | 3P | 80 A | OT80F3 |
| 015 | 3P | 80 A | OT80F3 |
| 019 | 3P | 80 A | OT80F3 |
| 023 | 3P | 100 A | OT100F3 |
| 025 | 3P | 100 A | OT100F3 |
| 029 | 3P | 100 A | OT100F3 |
| 033 | 3P | 100 A | OT100F3 |
| 037 | 3P | 125 A | OT125F3 |
| 041 | 3P | 125 A | OT125F3 |
| 042 | 3P | 160 A | OT160G03 |
| 048 | 3P | 160 A | OT160G03 |
| 056 | 3P | 200 A | OT200E03 |
| 064 | 3P | 200 A | OT200E03 |
| 072 | 3P | 250 A | OT250E03 |
| 078 | 3P | 250 A | OT250E03 |
| 088 | 3P | 250 A | OT250E03 |
| 096 | 3P | 315 A | OT315E03 |
| 112 | 3P | 400 A | OT400E03 |
| 128 | 3P | 400 A | OT400E03 |
| 144 | 3P | 630 A | OT630E03 |
| 162 | 3P | 630 A | OT630E03 |
| 176 | 3P | 630 A | OT630E03 |
| 192 | 3P | 630 A | OT630E03 |

7 WATER CONNECTIONS

7.1 EVAPORATOR

The connections schemes relating to evaporator are featured in the paragraph 7.4 HYDRAULIC VERSIONS

The connection tubes have to be supported adequately in order that their weight does not damage the plant.

It is necessary that the water flow rate to the unit is compatible with the evaporator one. It is also necessary that the water flow rate is kept uniform while the unit is running: it is suggested to use always a pump system dedicated to the unit and independent from the remaining part of the plant.

Before stalling units with temperature around 0°C please evacuate the exchanger with compressed air in order to avoid breakings due to ice.

If the unit is installed in order to replace another, the entire hydraulic system must be emptied and cleaned before the new unit is installed. Regular tests and proper chemical treatment of water are recommended before starting up the new unit.

In the event that glycol is added to the hydraulic system as anti-freeze protection, pay attention to the fact that intake pressure will be lower, the unit's performance will be lower and water pressure drops will be greater. All unit-protection methods, such as anti-freeze, and low-pressure protection will need to be reset. Before insulating water piping, check that there are no leaks.

Evaporator **nominal pressure (PN)** = 16 bar.

CAUTION: Install a mechanical water filter at the **water inlet** of each heat exchanger as featured in the par. 7.4 HYDRAULIC VERSIONS. Failure to install the filter allows access of solid particles and / or welding slag inside the heat exchanger. We recommend the installation of a filter having a filtering net with holes not exceeding 0.5 mm in diameter.

Trane cannot be held responsible for any damage to heat exchangers due to the lack of good quality water filters.

7.1.1 Calculation of total minimum water content, total optimal water content and flow rates

The chiller needs values of total minimum and total optimal water content according to the following tables:

| CCUF | | Plant side cold water heat exchanger | | | | |
|--------------------------------|------|--------------------------------------|--------------|-------|-----------------|-----------------|
| | | Vopt [m3] | Vmin [m3] | K | Q min [m3/h] | Q max [m3/h] |
| One refrigerant circuit | 013 | 0,45 | 0,26 | 242,5 | 4,5 | 14,9 |
| | 015 | 0,51 | 0,29 | 241,5 | 5,1 | 17,1 |
| | 019 | 0,58 | 0,33 | 240,8 | 5,8 | 19,2 |
| | 023 | 0,68 | 0,39 | 239,8 | 6,8 | 22,8 |
| | 025 | 0,79 | 0,45 | 102,8 | 7,9 | 26,3 |
| | 029 | 0,93 | 0,53 | 102,4 | 9,3 | 30,8 |
| | 033 | 1,09 | 0,62 | 55,9 | 10,9 | 36,2 |
| | 037 | 1,20 | 0,69 | 55,8 | 12,0 | 40,0 |
| | 041 | 1,31 | 0,75 | 55,7 | 13,1 | 43,6 |
| | 042 | 1,31 | 0,75 | 54,2 | 13,1 | 43,5 |
| Two refrigerant circuits sizes | 048 | 1,51 | 0,86 | 54,1 | 15,1 | 50,3 |
| | 056 | 1,79 | 1,02 | 53,9 | 17,9 | 59,7 |
| | 064 | 2,12 | 1,21 | 22,8 | 21,2 | 70,5 |
| | 072 | 2,34 | 1,34 | 22,7 | 23,4 | 78,2 |
| | 078 | 2,55 | 1,46 | 22,7 | 25,5 | 85,0 |
| | 088 | 2,84 | 1,62 | 16,3 | 28,4 | 94,8 |
| | 096 | 3,08 | 1,76 | 16,1 | 30,8 | 102,7 |
| | 112 | 3,50 | 2,00 | 15,7 | 35,0 | 116,6 |
| | 128 | 4,03 | 2,30 | 8,8 | 40,3 | 134,2 |
| | 144 | 4,59 | 2,63 | 8,6 | 45,9 | 153,2 |
| | 162 | 5,15 | 2,94 | 5,1 | 51,5 | 171,7 |
| | 176 | 5,58 | 3,19 | 5,0 | 55,8 | 186,1 |
| 192 | 5,98 | 3,41 | 4,9 | 59,8 | 199,2 | |

LEGEND:

- V:** minimum/optimal water content of the plant
- Q min:** minimum water flow to the heat exchanger
- Q max:** maximum water flow to the heat exchanger
- $\Delta T_{\text{max chiller}} = 10^{\circ}\text{C}$
- $\Delta T_{\text{min chiller}} = 3^{\circ}\text{C}$
- $\text{dpw} = K \cdot Q^2 / 1000 \quad Q = 0,86 P / \Delta T$

IMPORTANT: If pump driven by an inverter (either unit onboard pump or external pump) in every working condition the variation of the water flow rate must be as low as possible. Variation must be less than 10% of the nominal flow rate per minute

7.2 WATER TREATMENT

Before putting the unit into operation, clean the hydraulic circuit. Dirt, scales, corrosion residue and other extraneous material can accumulate inside the heat exchanger and reduce its heat exchanging capacity. Pressure drops can increase, as well, thus reducing water flow. Proper water treatment therefore reduces the risk of corrosion, erosion, scaling, etc. The most appropriate water treatment must be determined locally, according to the type of system and to the local characteristics of the process water.

Trane is not responsible for damage to or malfunctioning of the equipment caused by failure to treat water or by improperly treated water

Table - Acceptable water quality limits

| | | | |
|--------------------------------------------------------|---------|-------------------------------------------------------|-------|
| PH (25°C) | 6,8÷8,0 | Total Hardness (mg CaCO ₃ / l) | < 200 |
| Electrical conductivity S/cm (25°C) | < 800 | Iron (mg Fe / l) | < 1.0 |
| Chloride ion (mg Cl ⁻ / l) | < 200 | Sulfur ion (mg S ₂ ⁻ / l) | None |
| Sulphate ion (mg SO ₂₄ ⁻ / l) | < 200 | Ammonium ion (mg NH ₄ ⁺ / l) | < 1.0 |
| Alkalinity (mg CaCO ₃ / l) | < 100 | Silica (mg SiO ₂ / l) | < 50 |

7.3 WINTER FREEZE PROTECTION ON THE EVAPORATOR EXCHANGER

Two or more protection methods should be foreseen when designing the system as a whole:

1. Continuous water flow circulation inside piping and exchanger when ambient air temperature is holding below 5 °C. This implies what follows:

- if the water flow inside piping and exchanger of the unit is due to an external pump installed by the customer, the on/off command of this pump must always be the one provided by the unit controller through the relevant free potential contact in the electrical cabinet.
- as long as the ambient air temperature is holding below 5 °C the unit must always be electrically supplied. Moreover the customer pump, if present, must always be electrically supplied alike and functioning properly.

2. Addition of an appropriate amount of glycol inside the water circuit.

3. Additional heat insulation and sufficient heating of exposed piping.

IMPORTANT: Trane can provide various optional kits called for the protection of all the components of the hydraulic circuit inside the unit (pumps, pipes and tank). If you want to buy any please contact Trane .

4. Emptying and cleaning of the heat exchanger during the winter season.

It is the responsibility of the installer and/or of local maintenance personnel to ensure two or more of the described antifreeze methods. Continuously verify, through routine checks, that appropriate anti-freeze protection is maintained.

Failure to follow the instructions above could result in damage to some of the unit's components. Damage from freezing is not covered by the warranty.

CAUTION: The unit water pipes are not protected against the risk of water freeze-up when the unit is not electrically powered and when the power and control of the external water pump is not managed by the CCUF unit controller. The owner or local maintenance personnel must provide appropriate solutions to prevent freezing.

CAUTION: A power loss of 15 minutes during freezing can damage the evaporator.

7.4 HYDRAULIC VERSIONS

CCUF units are available in combination with various **external hydraulic kits** which are supplied separately from the unit and supplied directly by manufacturer.

The available modules are the following ones:

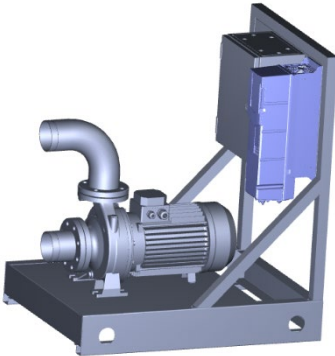

Single pump hydraulic kit with or without inverter

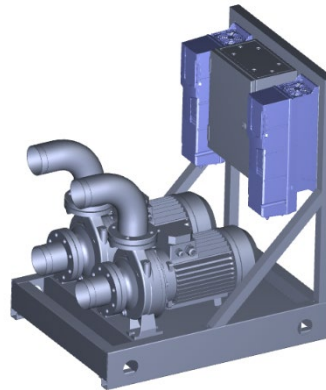

2 x single pumps hydraulic kit with or without inverter



Tank kit

Example of a possible configuration:

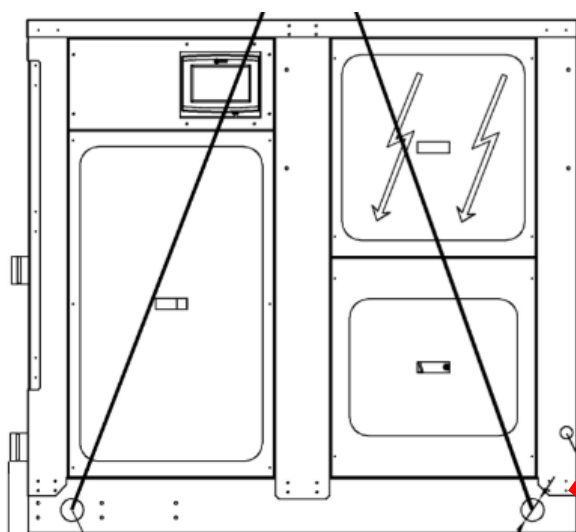

CCUF
without hydraulic kit

IMPORTANT:
Hydraulic and electrical connections between hydraulic kit(s) and the unit are at customer care.

Please consult the electrical drawing of the unit and the electrical drawing of the hydraulic kit to implement the electrical connections between them.

Terminals to be connected have the same labels on the electrical drawing of the unit and on the electrical drawing of the hydraulic kit. For further support please contact Trane.

The hydraulic kit requires a power supply line of its own.

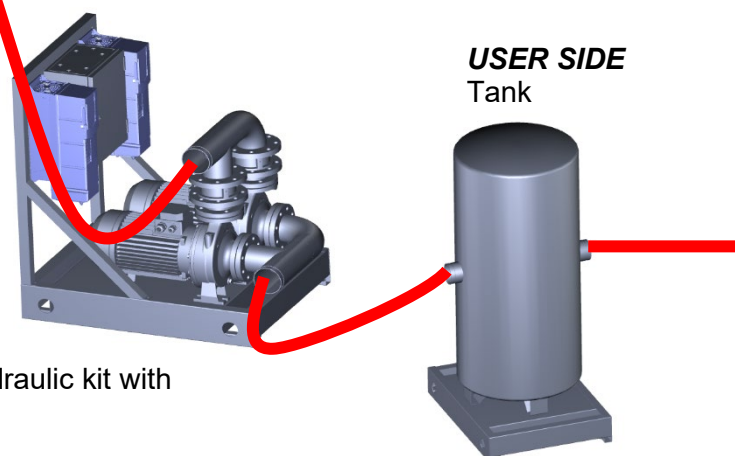

USER SIDE
Double pump hydraulic kit with inverter

USER SIDE
Tank

IMPORTANT: No hydraulic kits are provided for the biggest 4 sizes of CCUF (144 ÷ 192)

Optional Hydraulic accessories on the price list

- "Y" water strainer (sold separately), consists of body and stainless steel mesh (*), with replaceable filter through the inspection cap.
- Automatic water filling (sold separately).
- Water gauges kit
- Victaulic kit (**)

IMPORTANT: water strainer and flow switch must be installed on water circuit (user side) in order to keep the warranty. Since no water flow control device is installed on the unit, the flow switch is always provided as a loose accessory (optional) and must be installed by the customer.

(*) Water strainer with meshes not over 0.5mm

(**) A Victaulic kit must be provided for each component to be connected.

In case of selection of external hydraulic kit, it is necessary to provide **1 kit for the unit and 1 kit for the external hydraulic kit module.**

E.g. : CCUF + pump hydraulic kit + water tank + Victaulic kit

→ **Select nr. 3 Victaulic kits (1 kit for unit + 1 kit for pump hydraulic kit + 1 kit for water tank)**

7.4.1 Hydraulic diagram for CCUF units with no pump no tank

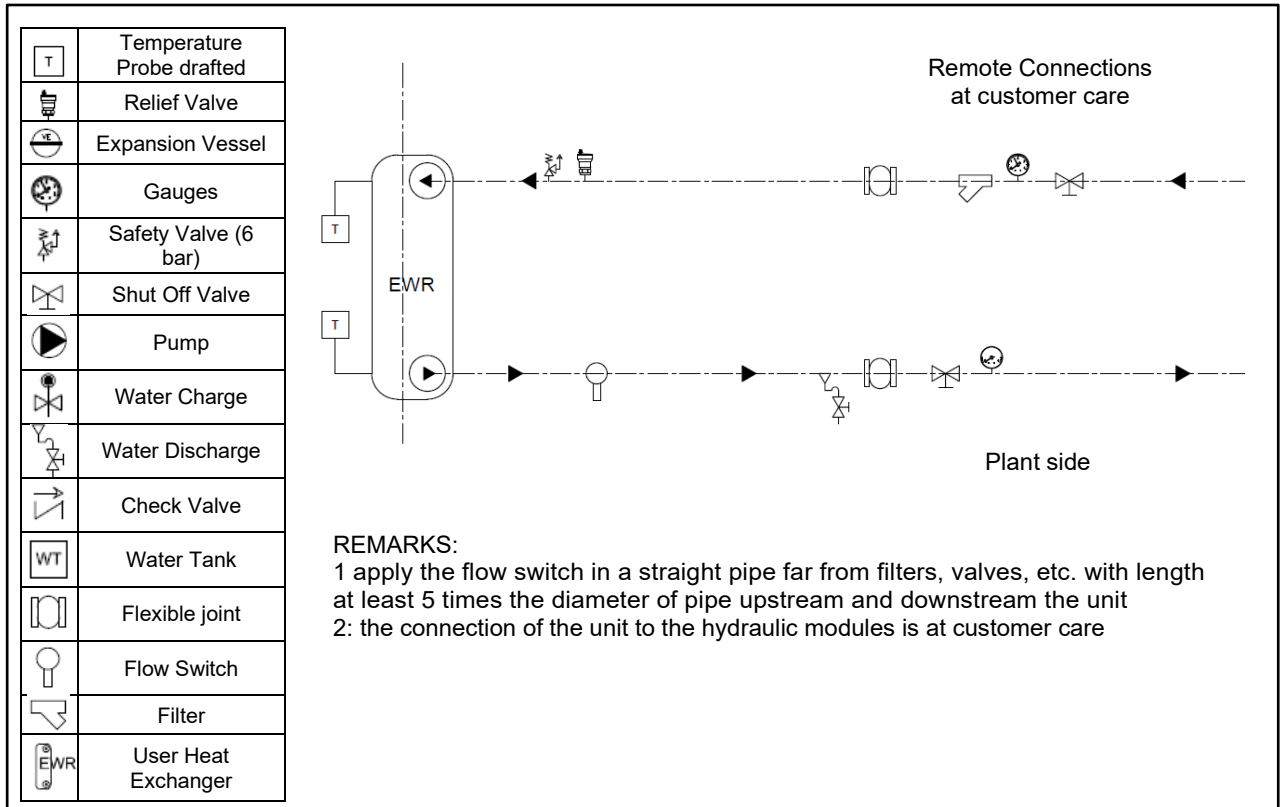

Figure 11

7.4.2 Hydraulic diagram for CCUF units and hydraulic module with 1 pump without tank

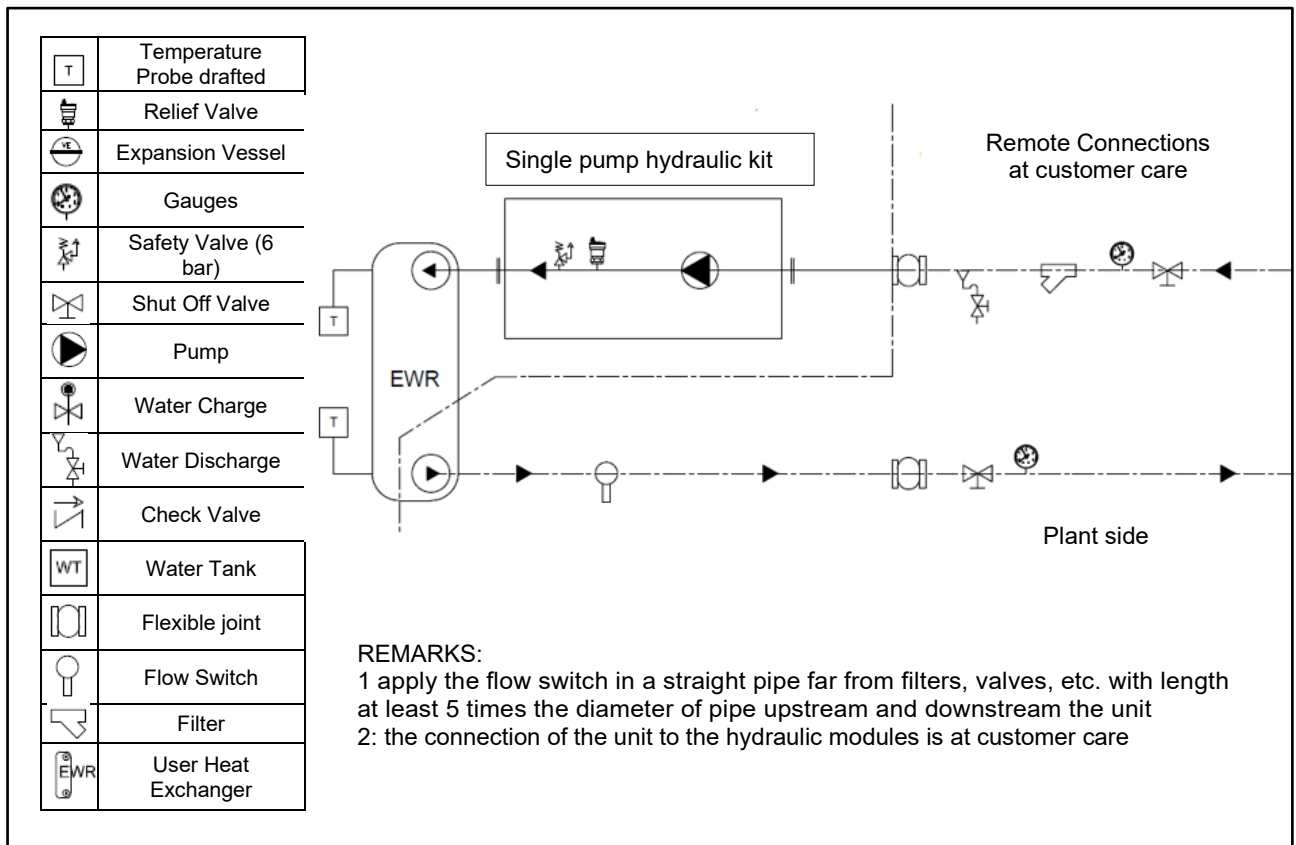

Figure 12

7.4.3 Hydraulic diagram for CCUF units and hydraulic module with 1 pump and tank

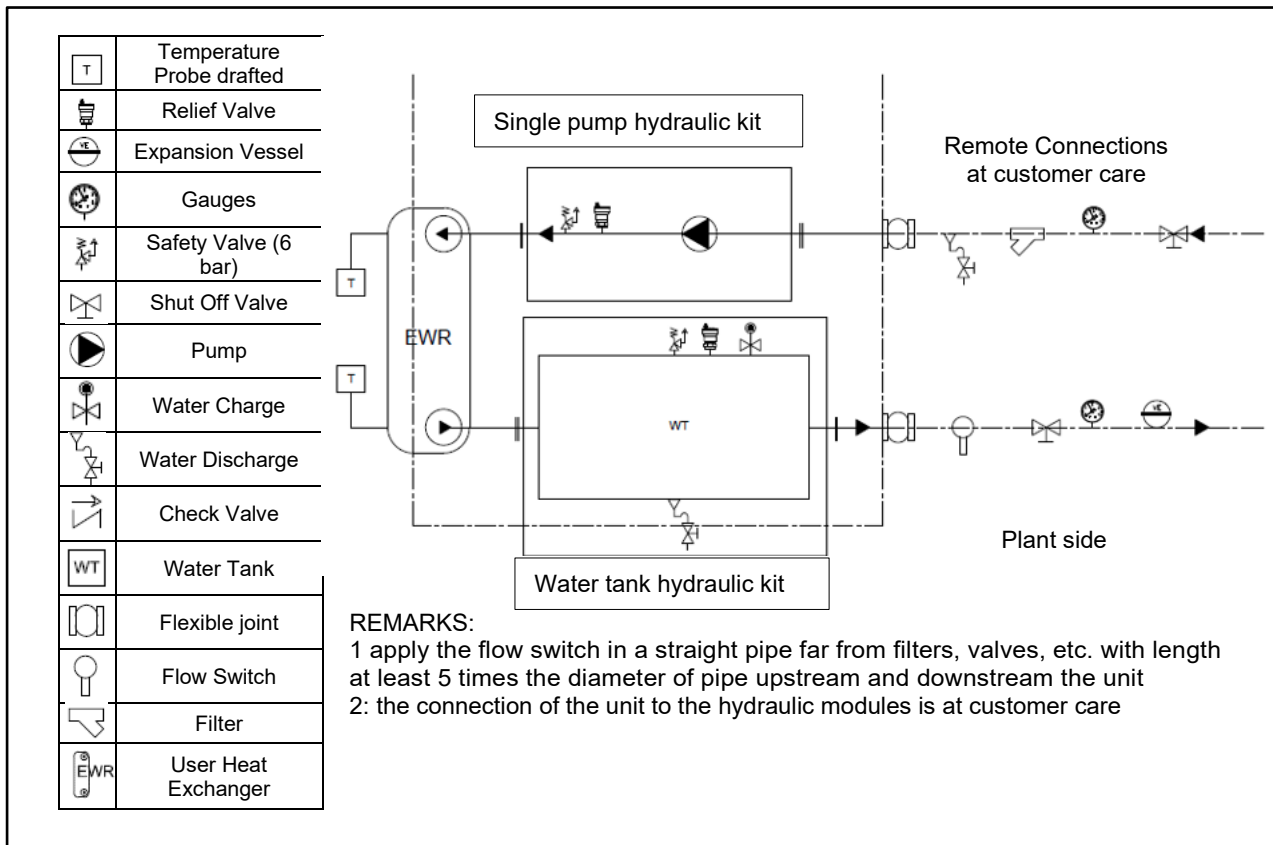

Figure 13

7.4.4 Hydraulic diagram for CCUF units and hydraulic module with 2 pumps without tank

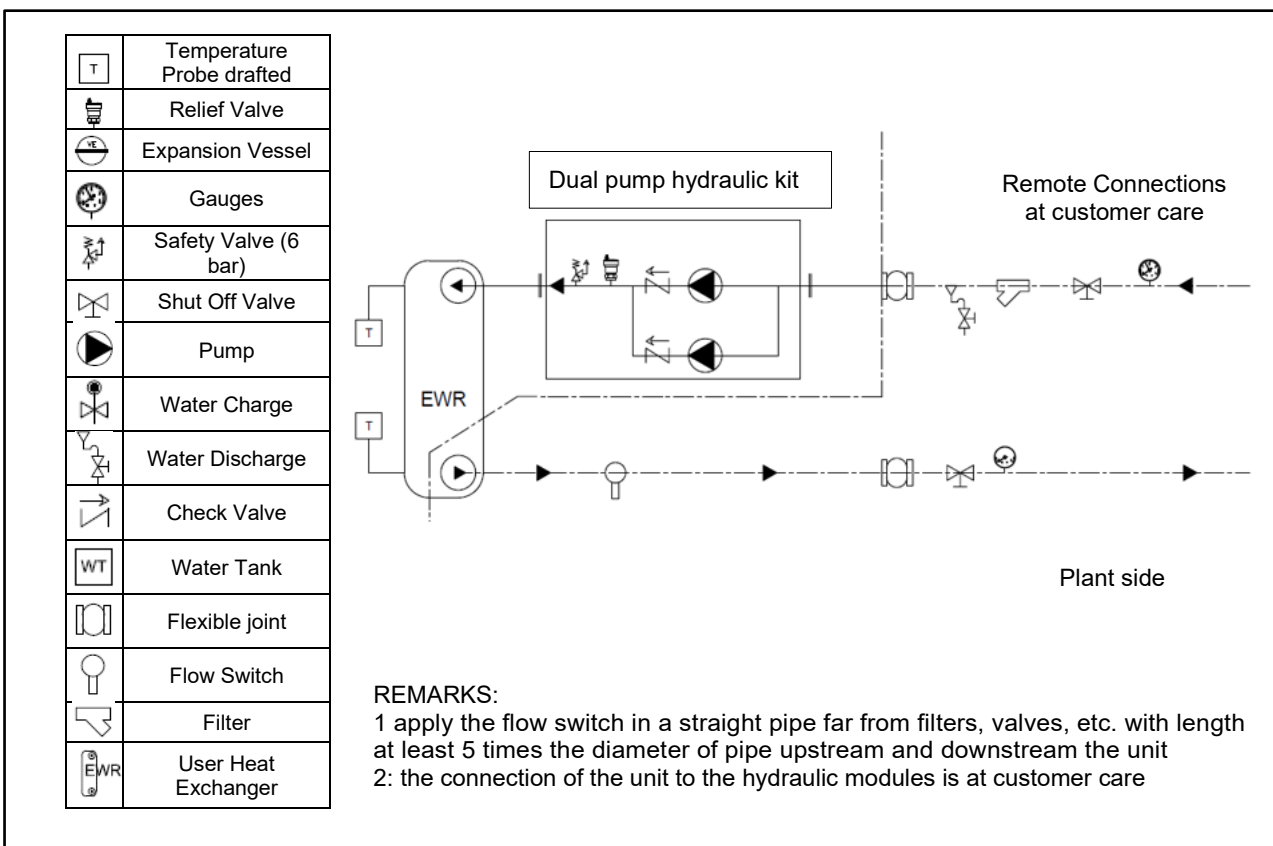

Figure 14

7.4.5 Hydraulic diagram for CCUF units and hydraulic module with 2 pumps and tank

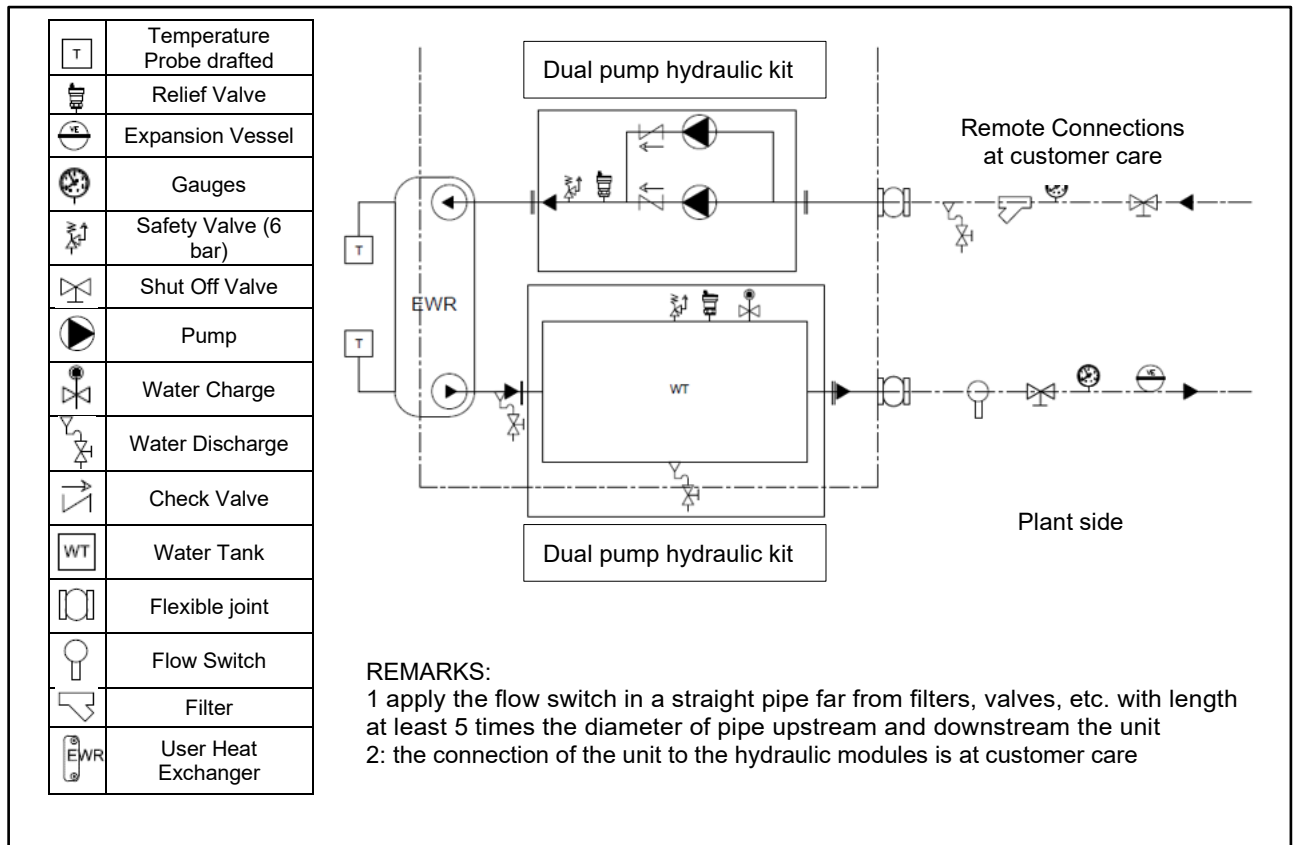

Figure 15

7.5 PUMPS CHARACTERISTICS

7.5.1 CCUF low head pressure pumps characteristics

USER SIDE

| | Mod. | Pf [kW] | qw [m ³ /h] | dpw [kPa] | Ref. Curve | F.L.I. [kW] | F.L.A. [A] | Hp [kPa] | Hu [kPa] |
|--------------------------------|------|------------|---------------------------|--------------|------------|----------------|---------------|-------------|-------------|
| One refrigerant circuit sizes | 013 | 52 | 9 | 19 | A | 1,72 | 3,8 | 216 | 196 |
| | 015 | 60 | 10 | 25 | A | 1,72 | 3,8 | 209 | 184 |
| | 019 | 67 | 12 | 32 | A | 1,72 | 3,8 | 203 | 171 |
| | 023 | 79 | 14 | 45 | B | 2,55 | 5,1 | 226 | 181 |
| | 025 | 92 | 16 | 25 | B | 2,55 | 5,1 | 220 | 195 |
| | 029 | 108 | 19 | 35 | B | 2,55 | 5,1 | 212 | 177 |
| | 033 | 126 | 22 | 26 | B | 2,55 | 5,1 | 202 | 176 |
| | 037 | 140 | 24 | 32 | B | 2,55 | 5,1 | 195 | 163 |
| | 041 | 152 | 26 | 38 | B | 2,55 | 5,1 | 187 | 149 |
| Two refrigerant circuits sizes | 042 | 152 | 26 | 37 | D | 4,52 | 8,7 | 256 | 219 |
| | 048 | 176 | 30 | 49 | D | 4,52 | 8,7 | 251 | 202 |
| | 056 | 208 | 36 | 69 | D | 4,52 | 8,7 | 243 | 174 |
| | 064 | 246 | 42 | 41 | D | 4,52 | 8,7 | 231 | 190 |
| | 072 | 273 | 47 | 50 | E | 6,09 | 10,6 | 244 | 194 |
| | 078 | 297 | 51 | 59 | E | 6,09 | 10,6 | 238 | 179 |
| | 088 | 329 | 57 | 53 | E | 6,09 | 10,6 | 230 | 177 |
| | 096 | 357 | 61 | 61 | E | 6,09 | 10,6 | 223 | 162 |
| | 112 | 405 | 70 | 77 | F | 8,26 | 13,6 | 259 | 182 |
| | 128 | 466 | 80 | 57 | F | 8,26 | 13,6 | 243 | 186 |

Pf = cooling capacity (kW)
qw = water flow (m³/h)
dpw = pressure drop (kPa)
F.L.I. = full load electrical power
F.L.A. = full load operating current
Hp = water pump head pressure
Hu = water pump available pressure

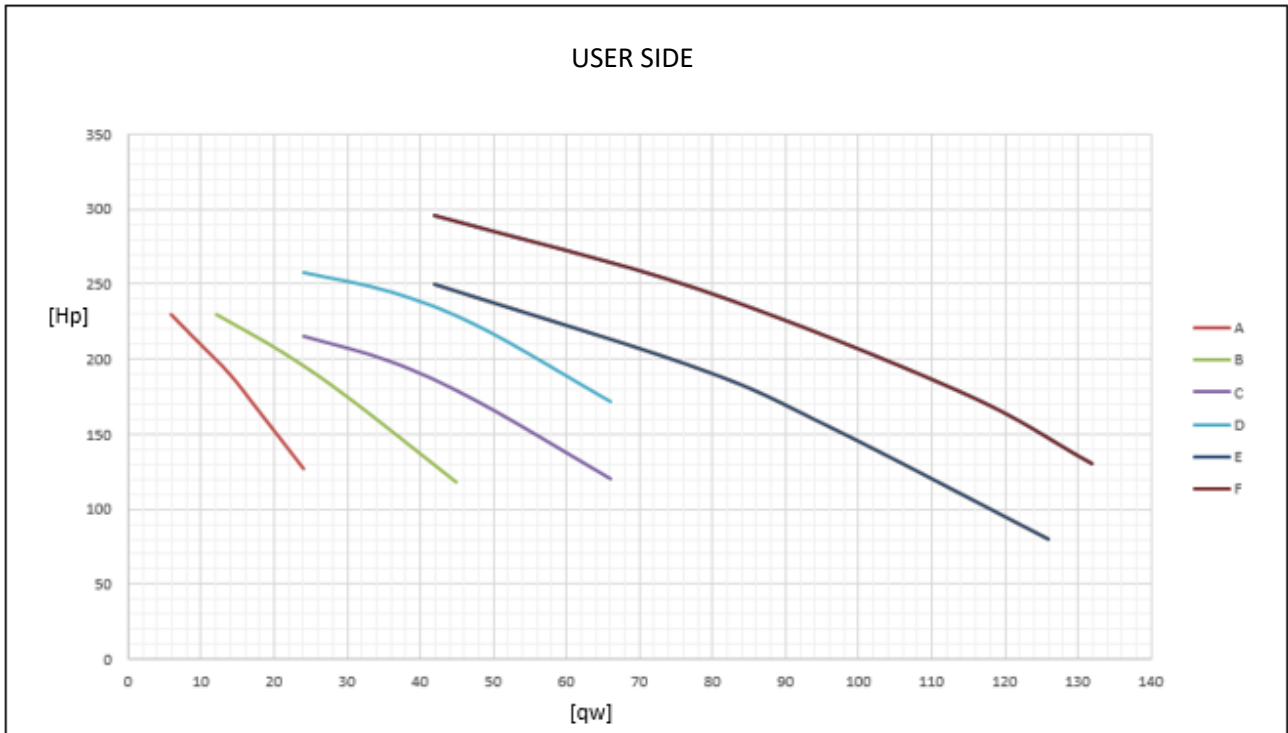

7.5.2 CCUF high head pressure pumps characteristics

USER SIDE

| | Mod. | Pf [kW] | qw [m ³ /h] | dpw [kPa] | Ref. Curve | F.L.I. [kW] | F.L.A. [A] | Hp [kPa] | Hu [kPa] |
|-----------------------------------|------|------------|---------------------------|--------------|------------|----------------|---------------|-------------|-------------|
| One refrigerant circuit sizes | 013 | 52 | 9 | 19 | A | 2,55 | 4,7 | 341 | 322 |
| | 015 | 60 | 10 | 25 | A | 2,55 | 4,7 | 333 | 308 |
| | 019 | 67 | 12 | 32 | A | 2,55 | 4,7 | 325 | 293 |
| | 023 | 79 | 14 | 45 | B | 3,44 | 6,4 | 376 | 331 |
| | 025 | 92 | 16 | 25 | B | 3,44 | 6,4 | 356 | 331 |
| | 029 | 108 | 19 | 35 | C | 4,52 | 8,7 | 353 | 318 |
| | 033 | 126 | 22 | 26 | C | 4,52 | 8,7 | 342 | 315 |
| | 037 | 140 | 24 | 32 | C | 4,52 | 8,7 | 333 | 301 |
| | 041 | 152 | 26 | 38 | C | 4,52 | 8,7 | 325 | 287 |
| | 042 | 152 | 26 | 37 | D | 8,26 | 13,6 | 381 | 344 |
| Two refrigerant circuits sizes | 048 | 176 | 30 | 49 | D | 8,26 | 13,6 | 377 | 327 |
| | 056 | 208 | 36 | 69 | D | 8,26 | 13,6 | 369 | 300 |
| | 064 | 246 | 42 | 41 | D | 8,26 | 13,6 | 358 | 317 |
| | 072 | 273 | 47 | 50 | D | 8,26 | 13,6 | 347 | 297 |
| | 078 | 297 | 51 | 59 | D | 8,26 | 13,6 | 337 | 278 |
| | 088 | 329 | 57 | 53 | D | 8,26 | 13,6 | 321 | 268 |
| | 096 | 357 | 61 | 61 | E | 10,12 | 17,2 | 229 | 168 |
| | 112 | 405 | 70 | 77 | F | 11,98 | 21,3 | 355 | 279 |
| | 128 | 466 | 80 | 57 | F | 11,98 | 21,3 | 339 | 282 |

Pf = cooling capacity (kW)
qw = water flow (m³/h)
dpw = pressure drop (kPa)
F.L.I. = full load electrical power
F.L.A. = full load operating current
Hp = water pump head pressure
Hu = water pump available pressure

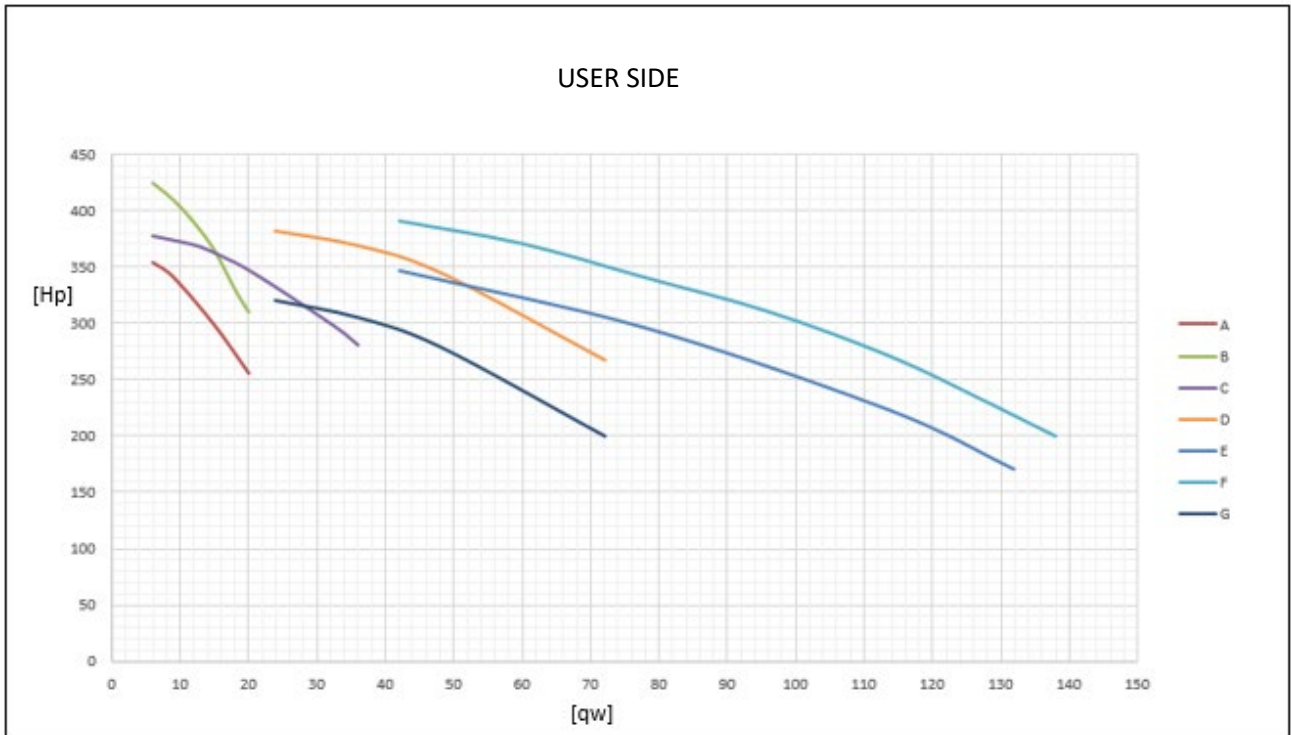

7.6 CUSTOMER PLANT SKETCHES

7.6.1 Customer plant sketch on the evaporator side of CCUF units with no on board unit pump

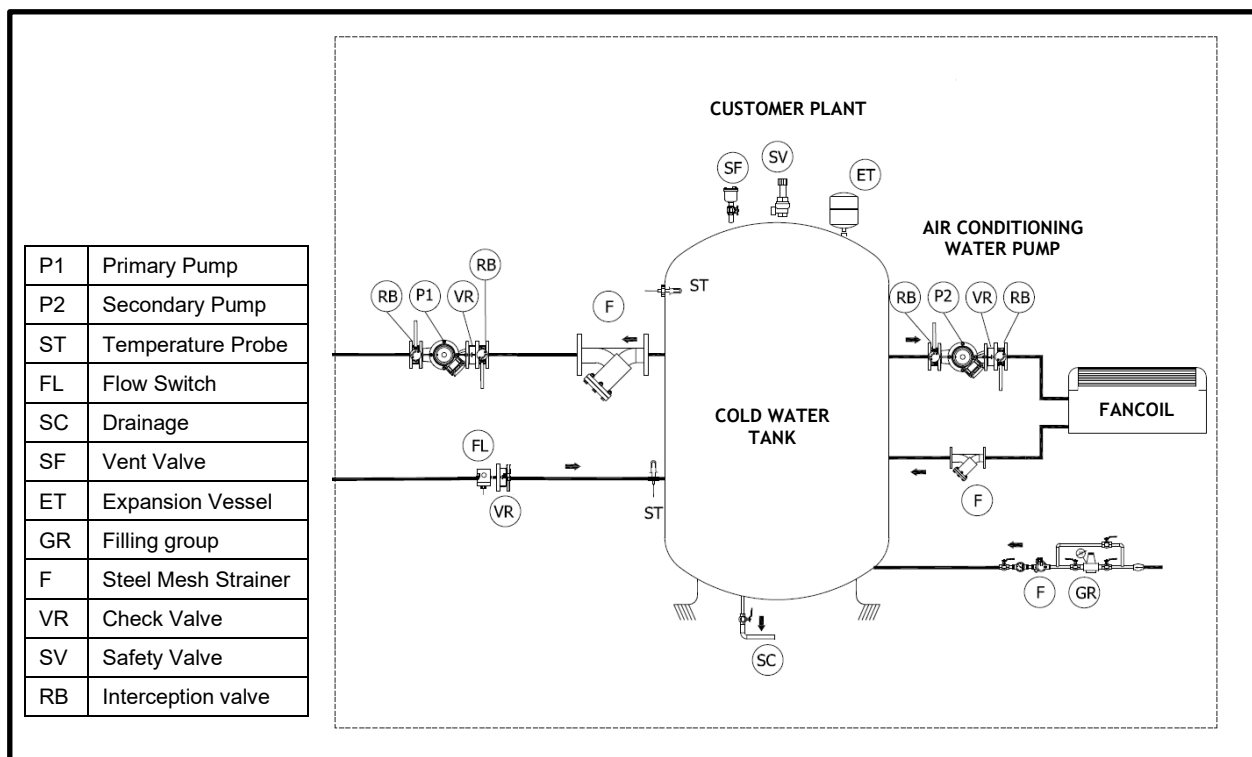

Figure 15

IMPORTANT: the flow switch and the steel mesh strainer in the customer plant are obligatory in order to keep the warranty

7.7 CUSTOMER PLANT SKETCHES

7.7.1 Customer plant sketch on the evaporator side

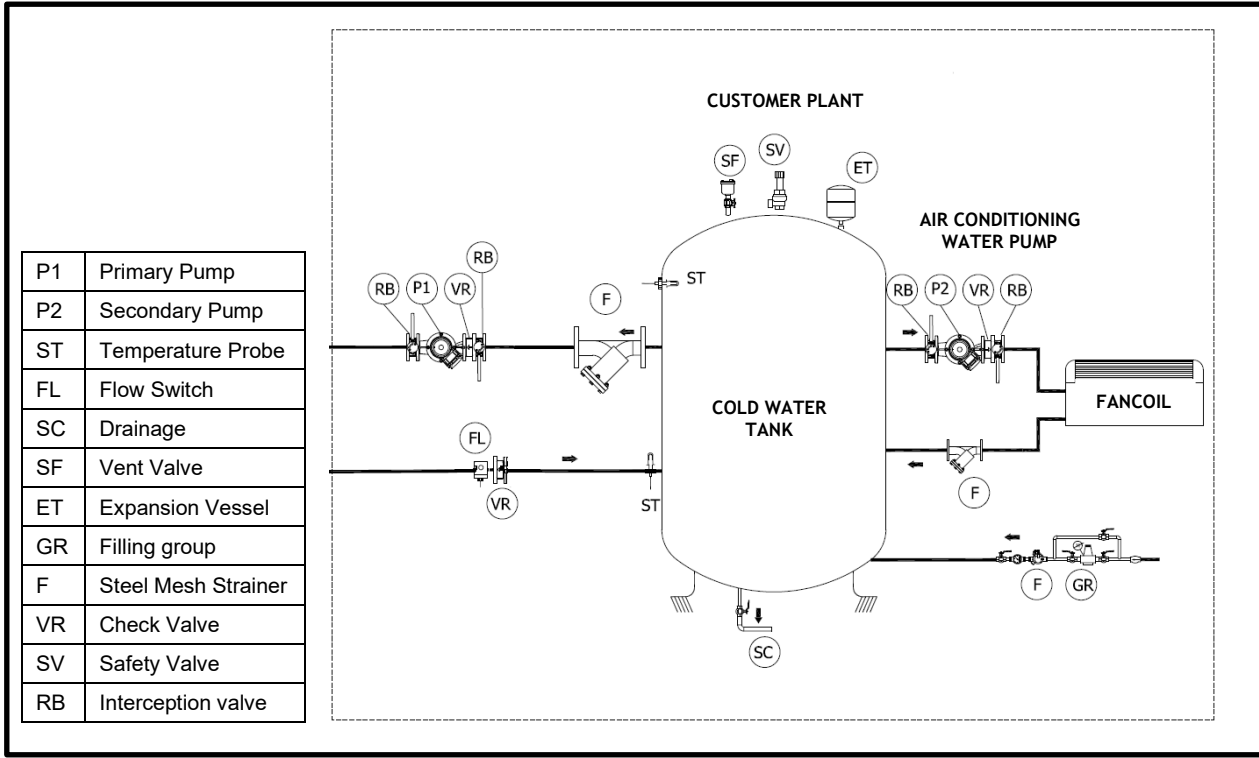

Figure 16

IMPORTANT: the flow switch and the steel mesh strainer in the customer plant are obligatory in order to keep the warranty

7.7.2 Flow switch installation

To ensure adequate water flow through the evaporator, it is essential to install a flow switch on the water circuit. The flow switch must be installed according to the relevant hydraulic diagram among those reported in the par 7.4 HYDRAULIC VERSIONS . The purpose of the flow switch is to stop the unit in case of an interruption of the water flow while protecting the evaporator from freezing. Since no water flow control is installed on board the unit, the installation of the flow switch, always provided as a loose accessory by Trane , in the customer's plant is mandatory.

The flow switch installation can be horizontal and vertical, screw-in thread, RP 1" (ISO7/1). It should be installed far from elbows or throttling with an arrow on flow direction. If pipe is vertical reclibrate range to balance paddle weight. If the device is downwards mounted take care to slugs, and apply it in a straight pipe far from filters, valves, etc with length at least 5 times the diameter of pipe upstream and downstream the unit. The paddles must be installed starting from the shortest.

Blade type flow switches are available as loose accessories and are suitable for harsh environments and for pipes with diameters from 1" to 8". The flow switch has a contact which must be wired, by the contractor, on the jobsite. Check the unit wiring diagram for more information. See the instruction sheet inside the flow switch box for information about positioning and settings.

Dimensions (mm)

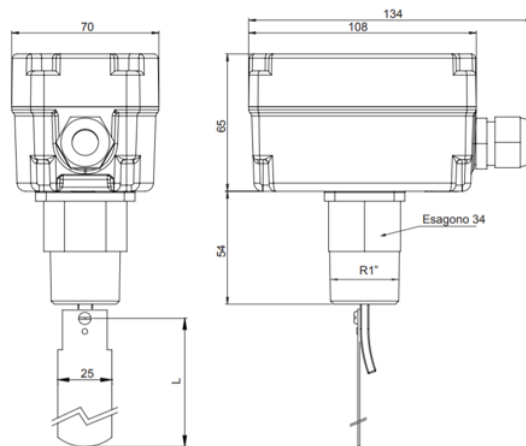

Figure 17

Paddle

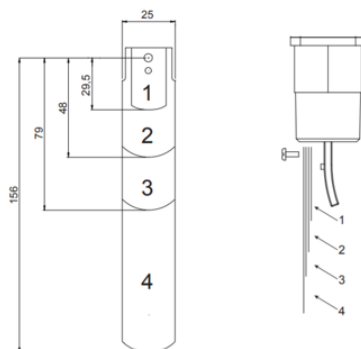
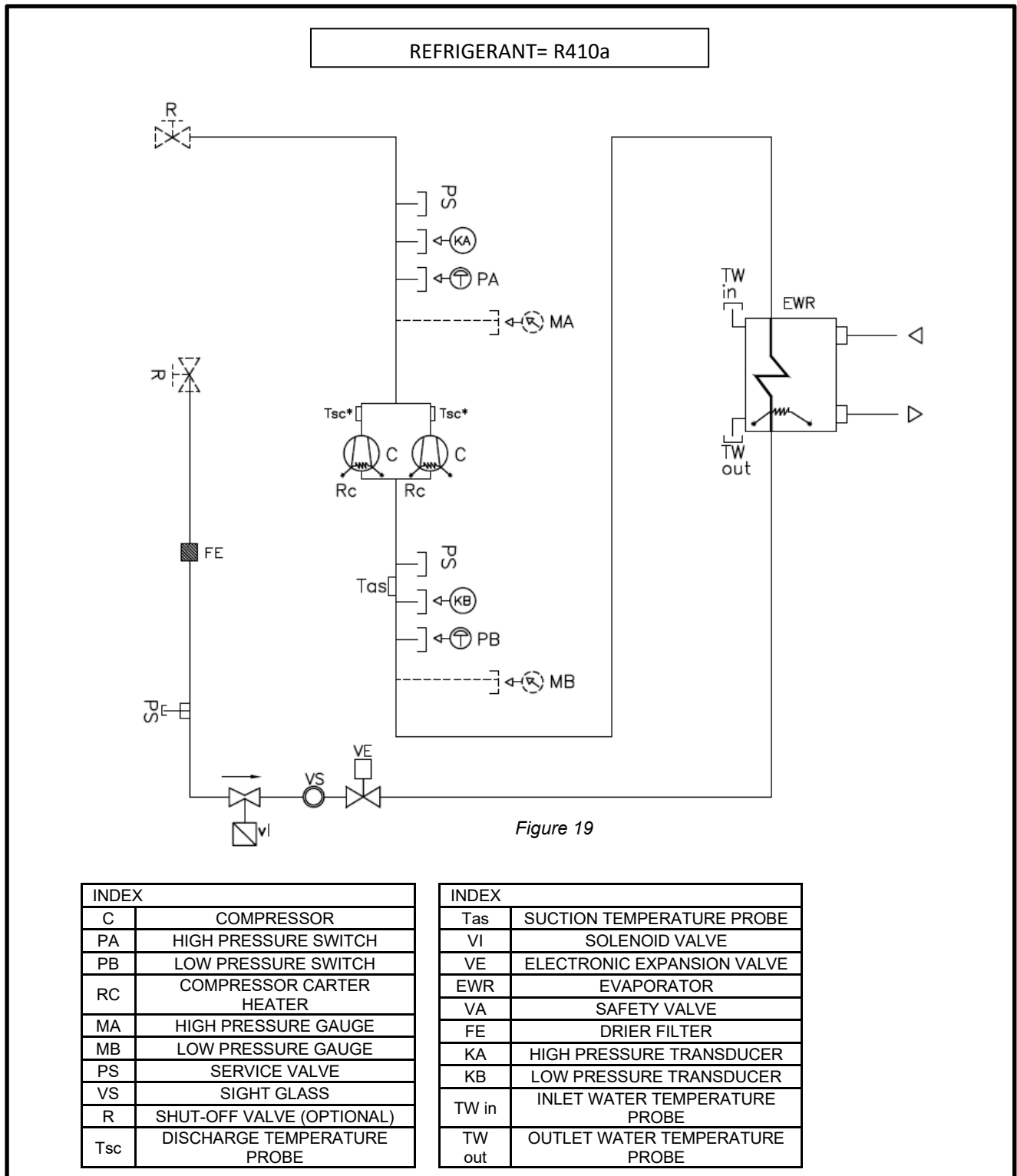

Figure 18

| PIPES | TABLES |
|--------|------------|
| 1" | 1 |
| 1 1/4" | 1 |
| 1 1/2" | 1, 2 |
| 2" | 1, 2 |
| 2 1/2" | 1, 2, 3 |
| 3" | 1, 2, 3 |
| 4" | 1, 2, 3 |
| 5" | 1, 2, 3 |
| 6" | 1, 2, 3, 4 |
| | 1, 2, 3 |
| 8" | 1, 2, 3, 4 |
| | 1, 2, 3 |

8 REFRIGERANT SCHEME



IMPORTANT:

Shut-off valves (aiming to avoid the refrigerant in the liquid line reaching dangerous pressure values due to direct sun irradiation) featured in the refrigerant scheme above are optional.

If they are installed remotely by the customer the above scheme must be complied with concerning their position

9 CONNECTION TO THE REMOTE CONDENSER

| CCUF | | CONNECTION LINES RECOMMENDED DIAMETERS | |
|--------------------------------|-----|----------------------------------------|--------------------|
| | | Discharge line Ø [mm] | Liquid line Ø [mm] |
| One refrigerant circuit sizes | 013 | 28 | 16 |
| | 015 | 28 | 16 |
| | 019 | 28 | 16 |
| | 023 | 28 | 16 |
| | 025 | 28 | 16 |
| | 029 | 35 | 28 |
| | 033 | 35 | 28 |
| | 037 | 35 | 28 |
| | 041 | 35 | 28 |
| Two refrigerant circuits sizes | 042 | 28 | 22 |
| | 048 | 28 | 22 |
| | 056 | 35 | 28 |
| | 064 | 35 | 28 |
| | 072 | 35 | 28 |
| | 078 | 35 | 28 |
| | 088 | 42 | 28 |
| | 096 | 42 | 28 |
| | 112 | 42 | 28 |
| | 128 | 42 | 28 |
| | 144 | 42 | 35 |
| | 162 | 42 | 35 |
| | 176 | 42 | 35 |
| 192 | 42 | 35 | |

IMPORTANT:

The party in charge of the supply of the condenser and of its refrigerant piping is responsible of implementing all the required protections to comply with the PED requirements for the design pressure of the condenser installed.

IMPORTANT:

The only electrical signals that the Trane CCUF unit provides to the remote condenser are:

- Enabling signal
- 0-10 V modulating signal

VERY IMPORTANT:

- Maximum **total length** between CCUF unit and the refrigerant condenser is **20 equivalent meters**. This means:
 - One piping bend corresponds to 1 equivalent meter
 - One-way valve corresponds to 4 equivalent meter
- In case the CCUF condenser-less unit will be placed at a lower level and the refrigerant condenser will be placed at a higher level (for example on the roof) the maximum vertical length must not exceed 10 meters (with "siphons")
- In case the CCUF condenser-less unit will be placed at a higher level and the refrigerant condenser at a lower level the maximum vertical length must not exceed 5 meters

During the commissioning, the correct oil return and sub-cooling have to be checked to avoid compressors damages. The sight glass should not show any gas bubbles during the start-up of the system. Sub-cooling is required.

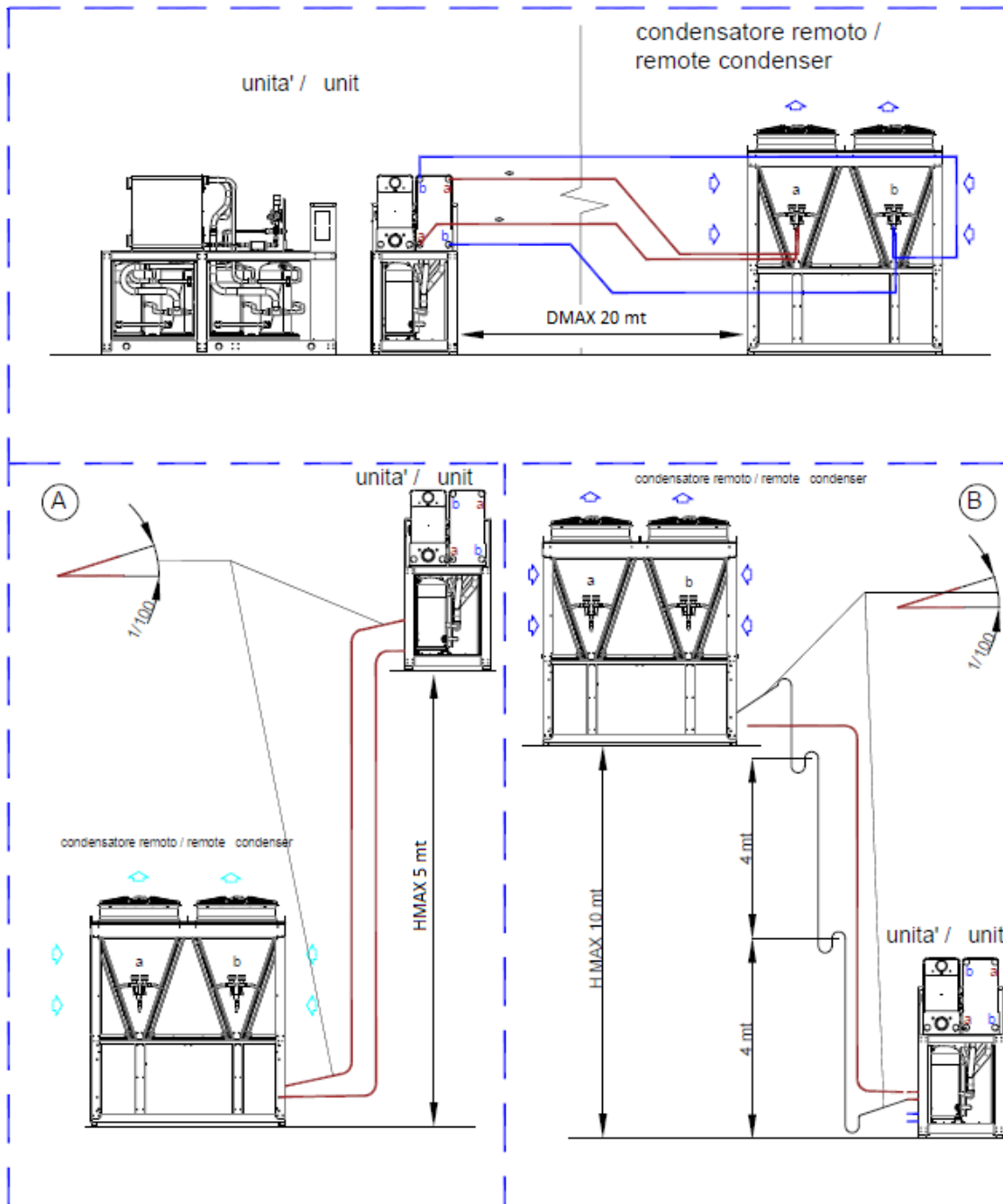

Diagrams showing the connection and maximum distances between CCUF unit and remote condenser

10 ELECTRICAL PANEL AND ELECTRICAL DATA

When reviewing this manual keep in mind.

- All field-installed wiring must be in accordance with local regulations, CE directives and guidelines. Be sure to satisfy proper equipment grounding requirements according CE
- The standardized values - Maximum Amps –Maximum kWatts are displayed on unit nameplate.
- All field-installed wiring must be checked for proper terminations, and for possible shorts or grounds.

Ensure total protection against the possible penetration of water into the connection point.

All the cables and the terminals are univocally numbered according to the electrical scheme in order to avoid possible misinterpretation. The identification system of the cables connected to the components allow also an easy and intuitive recognition of the component. Each component of the electrical panel is provided with an identification plate according to what is shown on the electrical scheme. All the connections to the electrical panel are made from the bottom and are equipped with cover preventing from break. The electrical panel supply is 400V/3ph+n/50Hz suitable for TN-S system and no additional power supply is necessary. If the unit is powered by a TN-C, TT or IT power supply system the Trane catalogue option “power supply without neutral 400V/3ph/50Hz” must have been ordered and implemented in the unit’s electrical cabinet. The entrance for the power cables is provided on the bottom of the box where a dismountable flange suitable for the purpose is provided.

The control circuit is powered with 24 VAC. Each unit is provided with auxiliary transformer control circuit 230/24V. It requires no additional power cable for the control equipment.

The unit has an antifreeze heater installed directly into the evaporator. The circuit also has an electric resistance installed in the compressor in order to keep warm the oil and thus avoid the transmigration of the refrigerant in its interior. Obviously the operation of the electrical resistors is ensured as long as the unit is power supplied. The unit is equipped with an alarm relay, which changes state every time an alarm occurs in one of the cooling circuits. Connect the terminals as per the wiring diagram on the unit - terminal “X” - a visual or audible alarm or any external supervision system.

BMS to monitor its operation is allowed. See the wiring diagram of the unit for wiring.

WARNING To avoid corrosion, overheating or general damage, at terminal connections, unit is designed for copper conductors only. In case of aluminum conductors an intermediate connection box must be added. In case of aluminum cable bi material connecting device is mandatory. Cable routing inside control panel should be made case by case by installer.

WARNING Hazardous Voltage with Capacitor! Disconnect all electric power, including remote disconnects and discharge all motor start/run and capacitors before servicing. Follow proper lock out/tag out procedures to ensure the power cannot be inadvertently energized.

For variable frequency drives or other energy storing components provided by Trane or others, refer to the appropriate manufacturer’s literature for allowable waiting periods for discharges capacitors. Verify with an appropriate voltmeter that all capacitors have discharged.

After disconnecting input power, wait five (5) minutes for units which are equipped with variable frequency drive (0V DC) before touching any internal components. Failure to follow these instructions could result in death or serious injury.

IMPORTANT if the unit is powered by a TT power supply system a differential protection should be suited for industrial machinery with current leak than can be higher than 500 mA (several motors and frequency drives)

VERY IMPORTANT due to the fact that the unit doesn’t mount a refrigerant high pressure safety valve and therefore the safety device for a high pressure event is the high pressure switch, shunt trip coils are installed on compressors automatic circuit breakers in order to ensure the compressors stop in case a high pressure event should occur and in the same moment the electronic control shouldn’t work properly. **This implies that if a high pressure event should occur a manual reset of the compressors automatic circuit breakers is needed.**

Electrical data

| | NOMINAL VALUES | | | | | | | | MAXIMUM VALUES | | | | |
|-------------------------------|----------------------------------------------------------------------------------------|-------------|--------|--------|--------|--------|-------|------------------------|----------------|--------|-------|--------------------------|------------------------|
| | condenser water temperature in/out 30/35°C, evaporator water temperature in/out 12/7°C | | | | | | | | | | | | |
| | CCUF | Compressors | | | TOTAL | | | | TOTAL | | | | |
| | | F.L.I. | F.L.A. | L.R.A. | F.L.I. | F.L.A. | S.A. | S.A. with soft starter | F.L.I. | F.L.A. | S.A. | L.R.A. with soft starter | S.A. with soft starter |
| kW | | A | A | kW | A | A | A | kW | A | A | A | A | |
| One refrigerant circuit sizes | 013 | 11,0 | 19,2 | 142,0 | 11,0 | 19,2 | 151,6 | 80,6 | 18,5 | 32,4 | 156,9 | 71,0 | 100,1 |
| | 015 | 12,9 | 22,5 | 147,0 | 12,9 | 22,5 | 158,3 | 84,8 | 21,5 | 36,6 | 161,9 | 73,5 | 103,1 |
| | 019 | 14,6 | 25,6 | 147,0 | 14,6 | 25,6 | 159,8 | 86,3 | 24,1 | 41,2 | 166,5 | 73,5 | 107,7 |
| | 023 | 17,4 | 30,4 | 197,0 | 17,4 | 30,4 | 212,2 | 113,7 | 29,2 | 49,9 | 218,7 | 98,5 | 139,9 |
| | 025 | 19,5 | 34,1 | 197,0 | 19,5 | 34,1 | 214,0 | 115,5 | 32,8 | 56,3 | 225,2 | 98,5 | 146,4 |
| | 029 | 22,7 | 39,8 | 197,0 | 22,7 | 39,8 | 216,9 | 118,4 | 38,4 | 64,1 | 255,2 | 98,5 | 164,4 |
| | 033 | 26,4 | 46,1 | 227,0 | 26,4 | 46,1 | 250,1 | 136,6 | 43,9 | 71,8 | 262,9 | 107,5 | 172,1 |
| | 037 | 28,8 | 50,4 | 260,0 | 28,8 | 50,4 | 285,2 | 155,2 | 48,6 | 80,1 | 295,9 | 130,0 | 191,9 |
| | 041 | 31,8 | 55,6 | 260,0 | 31,8 | 55,6 | 287,8 | 157,8 | 53,3 | 88,4 | 304,2 | 130,0 | 200,2 |
| Two refrigerant circuit sizes | 042 | 33,3 | 58,3 | 344,0 | 33,3 | 58,3 | 387,7 | 215,7 | 54,7 | 92,1 | 225,8 | 172,0 | 162,6 |
| | 048 | 40,7 | 71,2 | 197,0 | 40,7 | 71,2 | 250,4 | 151,9 | 65,6 | 112,6 | 281,5 | 98,5 | 202,7 |
| | 056 | 46,1 | 80,7 | 227,0 | 46,1 | 80,7 | 287,5 | 174,0 | 76,8 | 128,1 | 334,7 | 107,5 | 243,9 |
| | 064 | 53,6 | 93,7 | 227,0 | 53,6 | 93,7 | 297,3 | 183,8 | 87,9 | 143,6 | 334,7 | 107,5 | 243,9 |
| | 072 | 58,2 | 101,8 | 260,0 | 58,2 | 101,8 | 336,4 | 206,4 | 97,3 | 160,2 | 351,3 | 130,0 | 260,5 |
| | 078 | 64,4 | 112,8 | 260,0 | 64,4 | 112,8 | 344,6 | 214,6 | 106,7 | 176,8 | 392,6 | 130,0 | 288,6 |
| | 088 | 71,6 | 125,3 | 320,0 | 71,6 | 125,3 | 414,0 | 254,0 | 122,3 | 199,9 | 438,2 | 160,0 | 320,6 |
| | 096 | 81,1 | 141,9 | 320,0 | 81,1 | 141,9 | 426,4 | 266,4 | 137,9 | 223,0 | 222,3 | 160,0 | 183,1 |
| | 112 | 90,2 | 157,9 | 344,0 | 90,2 | 157,9 | 462,4 | 290,4 | 153,1 | 252,2 | 525,9 | 172,0 | 388,3 |
| | 128 | 101,5 | 177,6 | 344,0 | 101,5 | 177,6 | 477,2 | 305,2 | 168,3 | 281,5 | 555,1 | 172,0 | 417,5 |
| | 144 | 119,1 | 208,4 | 320,0 | 119,1 | 208,4 | 493,7 | 333,7 | 206,9 | 334,5 | 572,8 | 160,0 | 455,2 |
| 162 | 130,1 | 227,7 | 344,0 | 130,1 | 227,7 | 533,8 | 361,8 | 222,1 | 363,7 | 637,4 | 172,0 | 499,8 | |
| 176 | 138,9 | 243,1 | 344,0 | 138,9 | 243,1 | 546,6 | 374,6 | 237,3 | 393,0 | 666,6 | 172,0 | 529,0 | |
| 192 | 150,6 | 263,6 | 344,0 | 150,6 | 263,6 | 563,6 | 391,6 | 252,5 | 422,2 | 695,9 | 172,0 | 558,3 | |

Electrical data referred to 400V - 3Phases+N - 50Hz

Maximum operating admitted conditions: 10%

Maximum phase unbalance: 2%

F.L.I. = Full load electrical power

F.L.A. = Full load operating current

S.A. = Sum of compressor motor locked rotor current (**L.R.A.**) of most powerful compressor plus F.L.A. of other compressor(s)

11 OPERATOR RESPONSIBILITIES

It is important that the operator is properly trained and familiar with the equipment before working on the unit. In addition to reading this manual, the operator must study the manual operation of the microprocessor and the wiring diagram to understand the sequence of start-up, operation, shutdown sequences, and the criterion of operation of all safety devices. During the initial start-up of the unit an authorized technician is available to answer any questions and educate on the proper functioning. We recommend the operator to maintain a record of the operating data for each unit installed and all maintenance activities and periodic service. If the operator observes abnormal or unusual operating conditions, consult the authorized service technician.

12 START-UP PRELIMINARY PROCEDURES

12.1 STARTING CHECK

Before starting the unit, even only momentarily, all the machinery supplied by the chilled water, like the air handling units, pumps, etc. have to be checked. The pump auxiliary contacts and the flow switch have to be connected to the control panel as indicated in the electrical diagram. Before carrying out interventions on the valve regulations, loosen the relevant valve gland. Open the discharge valve of the compressor. Open the liquid shutoff valve placed on the liquid line. Measure the suction pressure. If it is lower than 0.42 MPa pry open the solenoid valve on the liquid line by means of an electrical bridge. Bring the suction pressure to 0.45 MPa, then remove the jumper. Charge all the water circuit progressively. Starts up the water pump of the evaporator with the calibration valve shut and then slowly open it.

Discharge the air from the high points of the water circuit and check the direction of the water flow. Carry out calibration of the flow by using a measurer (if present or available) or by means of a combination of the readings of the manometers and the thermometers. In the starting phase calibrate the valve on the pressure difference read on the manometers, carry out drainage of the tubes and then carry out fine calibration on the temperature difference between the water in and the water out. The regulation is calibrated in the factory for water in to the evaporator at 12°C and water out at 7°C. With the general switch open, check that the electrical connections are tightly clamped. Check for any possible refrigerant leaks. Check that the electrical data on the label correspond to those of the mains supply. Check that the thermal charge available is appropriate for starting.

12.2 REFRIGERANT CHARGE

Trane CCUF units are shipped without any refrigerant charge

Danger: Do not use the compressor to vacuum the system.



13 CHECK LIST – MANDATORY OPERATION CONTROL BEFORE START-UP

| | | | |
|------|--|----|--|
| DATE | | N. | |
| UNIT | | | |

| | |
|------------------|-----------|
| CUSTOMER: | SITE: |
| | ADDRESS: |
| | POSTCODE: |
| | COUNTRY: |

THE INTENDED PURPOSE OF CCUF UNITS IS NOT FOR INDUSTRIAL PROCESS APPLICATION. PLEASE CONTACT TRANE TECHNICAL DEPARTMENT IN CASE OF INDUSTRIAL PROCESS APPLICATION.

GENERAL

| | | COMPLIANCE | |
|----|------------------------------------------------------------------------------------------------------------------------------------------------------------------------------------------------------------------------------------------------------------------------------------------------------------------------------------------------------------------------------------------------------------------------------------------------------------------------------------------------------------------------------------------------------------------------------------------------------------------------------------------------------------------------|------------|----|
| | | YES | NO |
| 1 | <p>THE HYDRAULIC CIRCUIT IS COMPLETE AND READY TO BE USED AND THE THERMAL LOAD IS AVAILABLE.</p> <p>PLEASE NOTE THAT THE FIRST START-UP SHALL NOT BE CARRIED OUT UNLESS THE PLANT IS READY AND THE WATER LOAD IS AVAILABLE.</p> | | |
| 2 | <p>THE UNIT DISPLAYS DENTS OR DAMAGES ON THE EXTERNAL CASING OCCURRED DURING THE TRANSPORTATION OR POSITIONING.</p> <p>IF ANY, SPECIFY BELOW:</p> <p>WARNING: PLEASE BE AWARE THAT RELEVANT DAMAGES CAUSED BY THE QUOTED CIRCUMSTANCES MAY RESULT IN THE CALL-OFF OF THE WARRANTY.</p> | | |
| 3 | <p>THE UNIT HAS BEEN INSTALLED IN ACCORDANCE WITH THE MINIMUM DISTANCE PROVIDED IN THE DIMENSIONAL DRAWING AND TECHNICAL DOCUMENTATION PROVIDED.</p> | | |
| 4 | <p>THE UNIT IS INSTALLED NEXT TO THE: PHOTOVOLTAIC SYSTEM, ELECTRONIC TRANSMITTERS ANTENNAS OR SIMILAR DEVICES.</p> | | |
| 5 | <p>THE UNIT IS POSITIONED ON A PERFECTLY FLAT (NOT INCLINED) SURFACE.</p> | | |
| 6 | <p>ANTI-VIBRATIONS DAMPERS HAVE BEEN INSTALLED BETWEEN THE UNIT AND THE FLOOR.</p> | | |
| 7 | <p>THE UNIT DISPLAYS DEFECTS OR DAMAGES RESULTING FROM MODIFICATIONS OR CHANGES (UNIT TAMPERING / UNAUTHORIZED MODIFICATIONS TO THE REFRIGERANT CIRCUIT OR THE HYDRAULIC CIRCUIT OR THE ELECTRICAL PANEL OR CHANGES TO THE UNIT OPERATING PARAMETERS) MADE BY A THIRD PERSON WITHOUT A WRITTEN AUTHORIZATION ISSUED BY TRANE.. THE UNIT SHALL BE CONFORM TO TRANE WIRING DIAGRAMS AND TECHNICAL DOCUMENTATION) IN CASE OF RELEVANT DIFFERENCE BETWEEN THE UNIT AND TRANE STANDARD CONFIGURATION PLEASE CONTACT TRANE .</p> <p>WARNING: PLEASE BE AWARE THAT RELEVANT DAMAGES CAUSED BY THE QUOTED CIRCUMSTANCES MAY RESULT IN THE CALL-OFF OF THE WARRANTY.</p> | | |
| 8 | <p>THE UNIT HAS BEEN INSTALLED VERY CLOSE TO A MARINE ENVIRONMENT OR AN AGGRESSIVE INSTALLATION ENVIRONMENT (HIGHLY CORROSIVE CHEMICAL AGENT).</p> <p>WARNING: PLEASE BE AWARE THAT RELEVANT DAMAGES CAUSED BY THE QUOTED CIRCUMSTANCES MAY RESULT IN THE CALL-OFF OF THE WARRANTY.</p> | | |
| 9 | <p>SPOTTED PRESENCE OF MOLD, MUSHROOMS, BACTERIA, MICROBIAL OF ANY TYPE.</p> | | |
| 10 | <p>THE UNIT DISPLAYS DAMAGES CAUSED BY: FLOODS, LIGHTNING, FIRE, ANY ACCIDENT BEYOND TRANE CONTROL.</p> | | |

ELECTRIC AND ELECTRONIC

| | | COMPLIANCE | |
|----|-----------------------------------------------------------------------------------------------------------------------------------------------------------------------------------------------------------------------------------------------------------------------------------------------------------------------------------------------|------------|----|
| | | YES | NO |
| 11 | THE UNIT IS ELECTRICALLY POWERED AND ALL THE RELEVANT ELECTRICAL WIRES ARE PROPERLY CONNECTED. | | |
| 12 | ELECTRICAL SUPPLY HAS BEEN INSTALLED IN ACCORDANCE WITH THE INSTRUCTIONS PROVIDED AT THE NAME PLATE AND IN THE TECHNICAL DOCUMENTATION. (ELECTRICAL POWER SUPPLY: 230V/400V +/- 10% - MAXIMUM "% OF PHASE IMBALANCE: +/- 2%). IT IS RECOMMENDABLE TO CHECK BY USING A TESTER THE VOLTAGE VALUE (BETWEEN PHASES AND BETWEEN PHASE AND NEUTRAL) | | |
| 13 | PHASES ARE CONNECTED IN THE PROPER SEQUENCE. | | |
| 14 | ELECTRICAL CABLES SIZE ARE CONFORM TO FLA MAX VALUE. | | |
| 15 | BOTH EXTERNAL AND INTERNAL ELECTRICAL WIRES ARE WELL TIGHTENED. | | |
| 16 | THE COMPRESSOR CRANCKCASE HEATERS HAVE BEEN POWERED AND HEATED AT LEAST 8 HOURS BEFORE THE START-UP | | |
| 17 | AN ELECTRONIC SUPERVISOR (OR ANY ADDITIONAL CONTROLLER) HAS BEEN INSTALLED. | | |
| 18 | THE CONNECTION WIRES ARE SHIELDED. | | |
| 19 | REMOTE CONTROL DEVICES OR INTERFACES ARE CONNECTED TO THE ELECTRICAL PANEL IN CONFORMITY WITH TRANE WIRING DIAGRAMS | | |
| 20 | ELECTRONIC DEVICES ARE INTACT AND DON'T DISPLAY ANY DAMAGE. | | |
| 21 | AN EXTERNAL WATER PUMP IS ELECTRICALLY CONNECTED TO THE ELECTRICAL PANEL IN ACCORDANCE WITH THE WIRING DIAGRAMS PROVIDED BY TRANE | | |
| 22 | THE ELECTRICAL ABSORPTION AND THE WATER PUMP OVERHEATING ARE STANDARD. | | |

REFRIGERANT CIRCUIT

| | | COMPLIANCE | |
|----|------------------------------------------------------------------------------------------------------------------------------------------------------------------------------------------|------------|----|
| | | YES | NO |
| 23 | ALL CONNECTIONS ON THE REFRIGERANT CIRCUITS ARE WELL TIGHTENED. | | |
| 24 | THE ELECTRONIC LEAKAGE DETECTOR OR THE PRESSURE GAUGE LEVEL INSTALLED ON THE REFRIGERANT CIRCUIT HAVE DETECTED ANY LEAKAGE. IF ANY, SPECIFY BELOW: | | |
| 25 | THE COMPRESSOR OIL INDICATOR LIGHT POINTS THE MAXIMUM LEVEL. | | |
| 26 | THE FILTER INDICATOR LIGHT ON THE LIQUID LINE IS GREEN. WARNING: THE YELLOW INDICATOR LIGHT INDICATES PRESENCE OF MOISTURE IN THE CIRCUIT. IN THIS CASE PLEASE CONTACT TRANE . | | |

WATER CIRCUIT

| | | COMPLIANCE | |
|----|--------------------------------------------------------------------------------------------------------------------------------------------------------------------------------------------------------------------------------------------------------------------------------------------------------------------------------------------------------------------------------------------------------------------------------------------------------------------------------------------|------------|----|
| | | YES | NO |
| 27 | <p>THE FILTER IS INSTALLED ON THE HEAT EXCHANGER INLET WATER PIPES, WITH A MAXIMUM DISTANCE OF 2 METERS FROM THE UNIT.</p> <p>PLEASE NOTE THAT THE FILTER INSTALLATION IS MANDATORY. FOR FURTHER TECHNICAL INFORMATION RELATING THE FILTER PLEASE REFER TO THE TECHNICAL DOCUMENTATIONS.</p> | | |
| 28 | <p>THE FLOW SWITCH HAS BEEN INSTALLED AND ELECTRICALLY CONNECTED. PLEASE NOTE THAT FLOW SWITCH INSTALLATION IS MANDATORY.</p> | | |
| 29 | <p>THE VALVES ON THE WATER PLANT MUST BE OPENED. PLEASE BE AWARE THAT IF THE MACHINE IS POWERED (OR IN STAND-BY MODE) PUMPS WILL START IF THE WATER TEMPERATURE IS EQUAL OR BELOW 4°C. CLOSING THE VALVES MAY THEREFORE CAUSE SEVERE DAMAGES.</p> | | |
| 30 | <p>DRAINAGE VALVES ARE INSTALLED. THE DRAINAGE VALVES ARE INSTALLED ON THE LOWEST POINT. THE UTILIZATION OF AUTOMATIC DRAINAGE VALVES IS RECOMMENDED.</p> | | |
| 31 | <p>AUTOMATIC OR MANUAL PURGE VALVES ARE INSTALLED.</p> <p>AUTOMATIC OR MANUAL PURGE VALVES ARE INSTALLED ON THE HIGHEST POINT.</p> | | |
| 32 | <p>THE HYDRAULIC CIRCUIT HAS BEEN FILLED AND PURGED.</p> <p>THE PLANT SHALL BE PURGED SEVERAL TIMES BEFORE STARTING UP THE UNIT. THE FILTER INSTALLED NEXT TO THE HEAT EXCHANGER SHALL BE CLEANED SEVERAL TIMES BEFORE STARTING UP THE UNIT, UNTIL THE CORRECT DELTA T IS ASSURED AND THE HYDRAULIC PRESSURE IS CONFORM TO THE PLANT AND TO THE WATER PRESSURE DROPS. FOR FURTHER TECHICAL INFORMATIONS PLEASE REFER TO TRANE DOCUMENTATIONS AND PROCEDURE FOR THE FIRST START UP.</p> | | |
| 33 | <p>HYDRAULIC CONNECTIONS TO THE UNIT ARE COMPLIANT WITH THE UNIT NAME PLATE AND DIMENSIONAL DRAWINGS (HOT WATER INLET, HOT WATER OUTLET, COLD WATER INLET, COLD WATER OUTLET, EXT.).</p> | | |
| 34 | <p>RUBBER JOINTS ARE INSTALLED ON THE HYDRAULIC CONNECTIONS, IN ORDER TO MINIMIZE VIBRATIONS BETWEEN THE UNIT AND WATER PIPES.</p> | | |
| 35 | <p>SHUTOFF VALVES ARE INSTALLED ON THE HYDRAULIC CIRCUIT.</p> | | |
| 36 | <p>THE EXPANSION TANK IS INSTALLED ON THE HYDRAULIC CIRCUIT. EXPANSION TANK CAPACITY CONCURS WITH THE WATER PLANT CAPACITY.</p> | | |
| 37 | <p>TEMPERATURE PROBES AND PRESSURE GAUGES ARE INSTALLED ON THE HYDRAULIC CIRCUIT, BOTH INLET AND OUTLET SIDE.</p> | | |
| 38 | <p>THE HYDRAULIC CIRCUIT IS FREE FROM OBSTRUCTION OR ANY KIND OF CONSTRAINT.</p> | | |
| 39 | <p>BUFFER TANKS ARE INSTALLED IN THE HYDRAULIC CIRCUIT. THE BUFFER TANKS INSTALLATION IS STRONGLY RECOMMENDED IN ORDER TO WARRANTY THE OPTIMAL UNIT OPERATION.</p> <p>SPECIFY BUFFER TANK CAPACITY:LT</p> | | |
| 40 | <p>THE PRESSURE RELIEF VALVE IS INSTALLED BETWEEN DELIVERY AND RETURN PIPES.</p> <p>WARNING: IN ORDER TO AVOID <u>WATER-HAMMER</u>, THE RELIEF VALVE PRESSURE SHALL BE SET UP IN ACCORDANCE WITH THE STANDARD OPERATING PRESSURE OF THE WATER CIRCUIT.</p> | | |

| | | | |
|----|-------------------------------------------------------------------------------------------------------------------------------------------------------------------------------------------------------------------------------------------------------------------------------------------------------------------------------------------------------------------------------|--|--|
| 41 | <p>THE AUXILIARY HEATING SYSTEM IS INSTALLED IN THE WATER CIRCUIT IN ORDER TO AVOID THE START-UP OF THE UNIT WITH WATER TEMPERATURE BELOW 18°C. BEFORE STARTING UP THE UNIT THE INLET WATER TEMPERATURE MUST BE EQUAL OR HIGHER THAN 18°C.</p> <p>WARNING: THE UNIT SHALL NEVER WORK (NOT EVEN FOR SHORT PERIODS) WITH AN INLET WATER TEMPERATURE LOWER THAN 18°C.</p> | | |
| 42 | <p>ANTIFREEZE PROTECTIONS ARE INSTALLED IN THE WATER CIRCUIT (ELECTRICAL HEATERS ARE INSTALLED ON WATER PIPES AND TANKS).</p> <p>FOR FURTHER TECHNICAL INFORMATION PLEASE REFER TO TECHNICAL DOCUMENTATION PROVIDED. PLEASE NOTE THAT ANTIFREEZE PROTECTIONS ARE MANDATORY FOR OUTDOOR AIR TEMPERATURE LOWER THAN 3°C.</p> | | |
| 43 | <p>THE WATER CIRCUIT IS FILLED WITH ETHYLENE GLYCOL. ETHYLENE GLYCOL “%” SHALL CONFORM TO THE DATA PROVIDED IN THE TECHNICAL DOCUMENTATION.</p> | | |
| 44 | <p>ALL WATER PIPES ARE GROUND CONNECTED (IN ORDER TO AVOID ABNORMAL VOLTAGES THAT CAN CAUSE DANGEROUS CORROSIONS).</p> | | |
| 45 | <p>THE EVAPORATOR WATER FLOW IS COMPLIANT TO THE TECHNICAL DOCUMENTATION PROVIDED BY TRANE</p> | | |
| 46 | <p>THE WATER PUMPS ARE CORRECTLY SET UP IN ACCORDANCE WITH THE PLANT WATER FLOW, AVAILABLE HEAD PRESSURE AND PRESSURE DROP.</p> | | |
| 47 | <p>THE PUMP IMPELLERS ARE MECHANICALLY UNBLOCKED AND UNCLOGGED (FREE FROM ANY KIND OF CONSTRAINTS.)</p> | | |

| | | |
|--------------|-----------------------------------------------------------------------|-------------------------------------------------------------|
| DATE: | <u>AUTHORIZED SERVICE:</u> <u>NAME AND SIGNATURE</u> | <u>CUSTOMER:</u> <u>NAME AND SIGNATURE</u> |
|--------------|-----------------------------------------------------------------------|-------------------------------------------------------------|

13.1 REFRIGERANT CHARGE

13.1.1 Refrigerant replacement procedure with unit stopped and in vacuum (refrigerant charge in the liquid phase)

Open the shut off valve as far as possible so that it closes the service coupling. Connect the refrigerant cylinder to the service coupling without tightening the coupling. Half close the liquid shut off valve. If the circuit has been dehydrated and is in vacuum, charge the liquid by turning the cylinder upside down. Weigh and charge the appropriate quantity. Open the valve completely. Start up the unit and leave it running at full charge for some minutes. Check that the indicator is clear with no bubbles. Make sure that the transparency condition without bubbles is due to the liquid and not to the vapour. Correct functioning of the unit allows for overheating of 4 - 7° C and sub-cooling of 4 - 8°C. Values of overheating which are too high may be caused by a lack of refrigerant, whereas high sub-cooling values may mean an excess of charge. After intervention on the charge, it is appropriate to check that the unit runs within the declared values: with unit steadily running on a full charge, measure the temperature of the suction line downstream of the thermostatic valve bulb; read the balance pressure to the evaporator on the low pressure manometer and the corresponding saturation temperature. Overheating is equal to the difference between the temperatures measured in this way. Then measure the temperature of the liquid line coming out of the remote condenser and read the balance pressure to the remote condenser on the high -pressure manometer and the corresponding saturation temperature. The sub-cooling is the difference between these temperatures.

Danger While refrigerant is being added do not exclude any control system and let the water circulate in the evaporator to avoid the formation of ice.

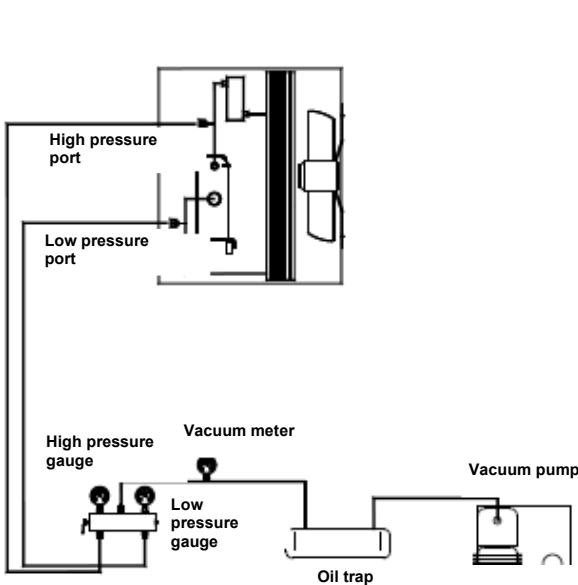

Figure 20

Refrigerant circuit diagram connection to vacuum pump

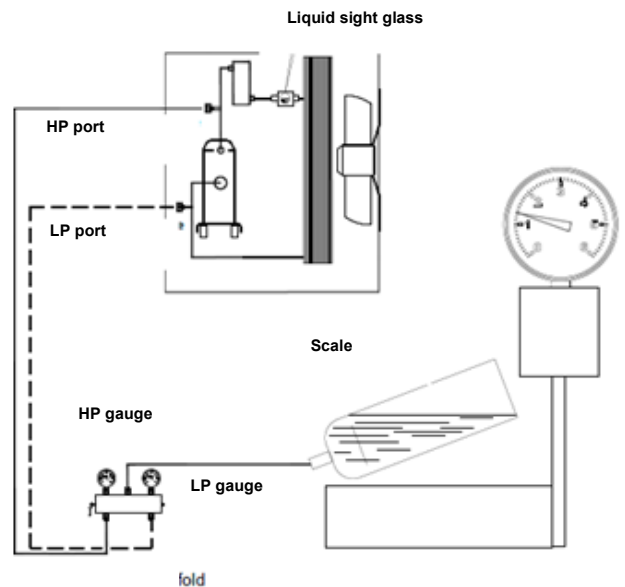

Figure 21

Refrigerant charge in the liquid phase

13.1.2 Refrigerant replacement procedure with unit running (refrigerant charge in the vapour phase)

Caution: charge vapour only. Do not charge liquid because it may damage the compressor.

Connect the refrigerant cylinder to the service valve without tightening the coupling. Drain the connection piping and tighten the coupling. Charge the circuit until the indicator indicates liquid without bubbles. Now the unit has the required charge. Make sure to not over-charge the circuit. Charging more than necessary leads to a higher delivery pressure, greater power consumption and possible damage to the compressor.

The symptoms of a low refrigerant charge are:

- o Low evaporation pressure
- o High value of superheating
- o Low value of sub-cooling

In this case, add refrigerant R410A. The system is provided with a charging port between the expansion valve and the evaporator. Charge refrigerant until conditions return to work normal. Remember to replace the cap closing the valve at the end.

IMPORTANT

If the unit has not been provided with integrated pump on board, do not turn off the external pump before 3 minutes have elapsed after turning off the last compressor. The early shutdown of the pump causes a water flow alarm failure.

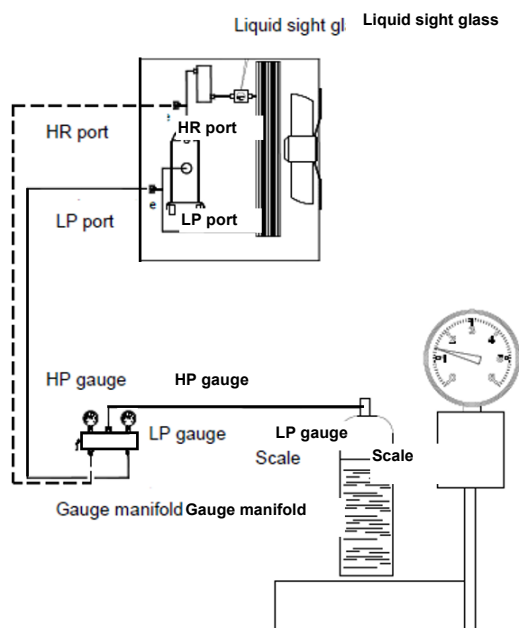

Figure 22

Refrigerant charge in the vapour phase

14 START-UP

14.1 PRELIMINARY CONTROLS

Before starting up the equipment it is very important to check that all the operations described in the paragraph "CHECK LIST – MANDATORY OPERATION CONTROL BEFORE START UP" have been carried out correctly.

Moreover check that all the mechanical and electric equipment has been tightened perfectly. Particular attention should be paid to the main components (compressor, exchangers, ventilators, electrical motors, and pump) if loose fastenings are found, tighten them well before starting up the machine.

The oil heaters have to be inserted at least 8 hours before starting up. Ensure that the compressors' carter is hot. Open the compressor valve and the cooling circuit one, which may have been shut for charging. Control all the machinery connected to the unit.

DANGER: The chilled water circuit may be under pressure. Bring down this pressure before opening up the system to rinse out or fill up the water circuit. Failure to comply with this instruction may cause accidental injury to maintenance personnel. If a cleaning solution is used in the chilled water circuit, the chiller must be isolated from the water circuit to avoid all the damage risks of the chiller and evaporator water pipes.

14.2 STARTING UP

Start up the unit by pressing the ON/OFF button. About 20 seconds pass from the moment in which the start-up request of the unit is given to the moment in which the (first) compressor starts. Three hundred and sixty seconds will pass from the last shut down to the next start-up of the same compressor.

Check the rotation direction of the compressors. If it is not the right one, invert two supply phases. Ensure that all the safety and control equipment is functioning correctly. Control the temperature of the water coming out of the evaporator and regulate the control setting if necessary. Control the oil level.

The oil type is POE.

14.3 WARM UP OF THE PLANT

In order to keep all the machine components in good condition and to optimise their use, during the warm up it is necessary to bring the circuit to the right temperature before releasing cooling or heating energy to the utilities.

The following steps must be followed for this to be carried out:

- * start up the machine
- * wait for the water temperature to reach the running temperature
- * start up the consumers

Follow the above mentioned procedure every time the plant is stopped long enough for the water temperature contained in it to vary considerably.

14.4 CONTROL OF THE OIL CHARGE

All the compressors mounted on Trane CCUF units are factory charged with oil whose chemical characteristic of stability are very good, so it is not necessary to change frequently the lubricant oil. The scroll compressors are equipped with an oil sight glass from which you can control the level. In tandem or trio performances, pay particular attention to oil level. Not perfectly leveled sight glasses between compressors in parallel, but falling in the upper and lower limits, are considered normal.

In case of burns for the electrical motor or fault of the compressor, it is necessary to make a test to check the acidity of the lubricant oil and, eventually, clean the circuit to reduce the acidity to correct values, mounting for instance an anti-acid filter and changing the oil in the circuit.

14.5 START UP PROCEDURE

- 1) With the switch closed, open the electrical panel and exclude compressor (refer to the wiring diagram on the unit). Close the panel, set switch to "ON" (to give power to the unit).
- 2) Wait for the start of the microprocessor and control. Make sure that the temperature of the oil is hot enough. The oil temperature must be at least 5°C higher than the saturation temperature of the refrigerant inside the compressor.
- 3) Place the unit in the "ON" and wait until the unit is indicated on the display-On.
- 4) Turn on the pumps (at max speed if with inverter).
- 5) Verify that the loss of load of the evaporator is equal to that of the project and correct if necessary. The pressure drop on the evaporator must be read on the service valves installed on the evaporator piping as a standard. Do not measure the load losses in points where any valves and / or filters are interposed.
- 6) Check for air in cleaning filters, and then drain the system.
- 7) Return the pump to the factory setting.
- 8) Turn off the power (into standby mode) and make sure the pumps stop after about 2 minutes.

Verify that the local temperature set point is set to the required value by pressing the Set button.

- 9) Turn the main switch to "OFF". Open the cabinet. Reactivate the compressors. Close the cabinet. Turn the main switch to "ON" (to give power to the unit).
- 10) Wait for the start of the microprocessor and control.
- 11) When the compressor is started, wait about 1 minute for the system begins to stabilize.
- 12) Check the pressure of evaporation and condensation of refrigerant.
- 13) Verify that, after a period of time necessary for the stabilization of the refrigerant circuit, the liquid indicator placed on the inlet pipe to the expansion valve is completely filled (no bubbles), and that the moisture indicator signs 'Dry'. The passage of bubbles within the liquid indicator may indicate a low amount of refrigerant, or an excessive pressure drop through the filter drier, or an expansion valve blocked at the maximum opening position
- 14) In addition to checking the sight glass, check the operating parameters of the circuit controlling:
 - a) Overheating compressor
 - b) Overheating compressor discharge
 - c) Sub-cooling of the liquid exiting the remote condenser
 - d) Evaporation pressure
 - e) Condensing pressure
- 15) Measure the values of pressure and temperature by means of the suitable instrumentation and make comparison by reading the corresponding values directly on the display of the microprocessor on board
- 16) To temporarily turn off the unit put on standby the unit key or open the remote contact (terminals shown in the wiring diagram provided with the unit) of the terminal X (by means of a remote switch installed by the customer) or set time zones. The microprocessor will activate the shutdown procedure that will take a few seconds. The unit water pump will be running on for two minutes after the unit has been switched off. Do not remove the main power to not turn off the electrical resistances of the compressor and the evaporator.

15 MAINTENANCE

Maintenance operations are fundamental in order to keep the units running properly, from both a purely functional and an energetic points of view.

Every Trane CCUF unit comes with a logbook, in which the user or the person delegated to machine maintenance can keep all the required notes, in order to keep a historical log of the Trane CCUF unit.

A lack of notes in the logbook could be considered proof of careless maintenance.

15.1 GENERAL

IMPORTANT

Beyond the cadences of checks recommended in the following, in order to keep the unit at optimum levels of performance and efficiency and prevent incipient failures, we recommend periodic visits of inspection and control of the unit by qualified personnel.

In particular, we recommend:

4 annual visits to units that operate about 365 days / year (quarterly)

2 visits per year for units with seasonal operation about 180 days / year (one at the start of the season and another one at mid-season)

1 annual visit for units with seasonal operation of about 90 days / year (starting seasonal)

It's important that during the initial start-up and periodically during operation routine checks are carried out. Among them you must also check the suction and condensation as well as the sight glass located on the liquid line.

Check through the microprocessor installed on the unit if the unit is working within normal parameters of superheating and sub-cooling. A routine maintenance program recommended is shown at the end of this chapter while a card collection of operating data is at the end of this manual. It is suggested to record on a weekly basis all the operating parameters of the unit. The collection of these data will be very useful to technicians, in case technical assistance is requested

Compressor Maintenance IMPORTANT

This inspection must be performed by qualified and trained personnel.

The analysis of vibration is a great tool for checking the mechanical conditions of the compressor.

It is recommended to check the value of the vibration immediately after starting and periodically on an annual basis.

Compressor Electrical Connections

It is very important that all the compressors are wired correctly for proper rotation. These compressors will not tolerate reverse rotation. Verify correct rotation/phasing using a rotation meter.

If wired incorrectly the compressor will make excessive noise, will not pump and will draw about half the normal current. It will also become very hot if allowed to run for an extended period.

NOTICE: Do not "bump" the compressor to check rotation as incorrect rotation could cause compressor motor failure in as little as 4 to 5 seconds!

Improper rotation of the compressors is indicated by a compressor module trip, noisy operation, no pressure difference on manifold gauges and low amp draw.

Compressor Replacement

If the chiller suffers a failed compressor, use these steps for replacement:

Each compressor has lifting eyes. Both lifting eyes must be used to lift the failed compressor.

After a mechanical failure of a compressor, it is necessary to change the oil in the remaining compressor and also replace the liquid line filter drier. After an electrical failure of a compressor, it will also be necessary to change the oil in the remaining compressor, replace the filters driers and add a suction filter drier with clean-up cores.

Make sure that a heater is correctly installed on the compressor. The heater helps prevent dry starts.

Note: Do not alter the refrigerant piping in any way as this can affect compressor lubrication.

Refrigerant System Open Time

The CCUF units use oil and therefore refrigerant system open time must be kept to a minimum.

The following procedure is recommended:

Leave a new compressor sealed until it is ready to be installed in the unit. Maximum system open time is dependent upon ambient conditions, but do not exceed one hour open time.

Plug the open refrigerant line to minimize moisture absorption. Always change the liquid line filter drier.

Do not leave oil containers open to the atmosphere. Always keep them sealed.

15.2 STANDARD CONTROLS

| Operations description | Recommended basis |
|----------------------------------------------------------------------------------------|-------------------|
| Compressors oil level check | monthly |
| Inlet temperature check (overheating) | monthly |
| Water circuits filling check | monthly |
| Compressors motors electrical input check | monthly |
| Power supply and auxiliary power voltage check | monthly |
| Refrigerant charge check through sight glass | monthly |
| Compressors carter heaters operation check | monthly |
| Tightening all electrical connections | monthly |
| Compressors and liquid circuit solenoid valve check | semiannual |
| Compressors contactors state check | quarterly |
| Evaporator heater operation check | quarterly |
| Pressure vessels conditions check | yearly |
| Check glycol concentration in the chilled water circuit if glycol presence is required | monthly |
| Check and clean the strainer | monthly |
| Check operation of all safety devices | annual |
| Carry out oil analysis and change the oil if necessary | annual |

Temperature and pressure probes – The unit comes factory-equipped with all the sensors listed below. Periodically check that their measurements are correct by means of sample instruments (manometers, thermometers); correct readings if necessary using the microprocessor keyboard. Well- calibrated sensors ensure better efficiency for the unit and a longer lifetime.

Note: refer to the microprocessor use and maintenance manual for a complete description of applications, setting and adjustments.

All sensors are preassembled and connected to the microprocessor. The descriptions of each sensor are listed below:

Outgoing water temperature sensor –This sensor is located on the evaporator outgoing water connection and is used by the microprocessor for antifreeze protection and to control the unit load according to the system thermal load.

IMPORTANT

In case a temperature control based on ingoing water temperature is needed please contact Trane before carrying out any trying to set it autonomously.

Ingoing water temperature sensor –This sensor is located on the evaporator ingoing water connection and is used for monitoring the return water temperature.

External air temperature sensor –This sensor allows to monitor the external air temperature on the microprocessor display and to manage the activation/deactivation of the compressors crankcase heaters

High pressure transducer –This allows to monitor the delivery pressure and to control the ventilators. Should an increase in condensation pressure occur, the microprocessor will control the circuit load in order to allow it to function even if choked. It contributes to complementing the oil control logic.

Low-pressure transducer –This allows to monitor the compressor suction pressure along with low pressure alarms. It contributes to complement the oil control logic and to manage the electronic expansion valve.

Compressor discharge temperature sensor – This allows to monitor compressor discharge temperature and oil temperature. The microprocessor shuts down the compressor in case of alarm in the event that the discharge temperature reaches 120°C

15.3 ORDINARY MAINTENANCE

| Activities list | week | Month (1) | Year (2) |
|------------------------------------------------------------------------|------|-----------|----------|
| General: | | | |
| Data collection operation (Note 3) | X | | |
| Visually inspect the unit for any damage and / or looseness | | X | |
| Verifying the integrity of the thermal insulation | | | X |
| Clean and paint where needed | | | X |
| Water Analysis (4) | | | X |
| Electric: | | | |
| Check the correct operation of the equipment on the unit | | | X |
| Check the wear of contactors - Replace if necessary | | | X |
| Check tightness of all electrical terminals - Tighten if necessary | | | X |
| Clean the inside of the electrical panel | | | X |
| Visual inspection of the components for signs of overheating | | X | |
| Check the operation of the compressor and the electric resistance | | X | |
| Measurement using a Megger insulation of the compressor motor | | | X |
| Refrigerant circuit: | | | |
| Perform a test of refrigerant leaks | | X | |
| Check through the sight glass coolant flow - Full Indicator | X | | |
| Carry out the analysis of the vibrations of the compressor | | | X |
| Carry out the analysis of the acidity of the oil of the compressor (5) | | | X |

Notes:

- 1) The monthly activities include all those weekly.
- 2) The annual activity (or earlier in the season), include all activities weekly and monthly.
- 3) The values of the unit should be recorded each day for a high level of observation.
- 4) Check for dissolved metals.
- 5) TAN (Total Acid Number):

| | |
|--------------------|---------------------------------------------------------------------------------------------------------------------------------------------|
| 0.10: | No action |
| From 0.10 to 0.19: | Repositioning filters antacid and occurs after 1000 hours of operation. Continue to replace the filters until the TAN not falls below 0.10. |
| > 0.19: | Changing the oil, oil filter and the filter drier, Refer to regular intervals. |

16 RECOMMENDED SPARE PARTS

There follows a list of the recommended parts for several years' running. Trane is at your disposal to recommend a personalized list of accessories according to the commissioned order, including the part number of the equipment.

| 1 YEAR | | 2 YEAR | | 5 YEAR | |
|-----------------------------|--------------|-----------------------------|--------------|-----------------------------|--------------|
| COMPONENTS | QUANTITY | COMPONENTS | QUANTITY | COMPONENTS | QUANTITY |
| fuses | (all) | fuses | (all) | fuses | (all) |
| filter dryers | (all) | filter dryers | (all) | filter dryers | (all) |
| solenoid valves | (1 per type) | solenoid valves | (all) | solenoid valves | (all) |
| electronic expansion valves | (1 per type) | electronic expansion valves | (all) | electronic expansion valves | (all) |
| pressure switches | (1 per type) | pressure switches | (all) | pressure switches | (all) |
| gas gauges | (1 per type) | gas gauges | (all) | gas gauges | (all) |
| contactors and relays | (1 per type) | contactors and relays | (all) | contactors and relays | (all) |
| thermal protectors | (1 per type) | thermal protectors | (all) | thermal protectors | (all) |
| carter electric heaters | (1 per type) | carter electric heaters | (all) | carter electric heaters | (all) |
| check valve | (1 per type) | check valve | (1 per type) | check valve | (all) |
| sight glass | (1 per type) | sight glass | (1 per type) | sight glass | (all) |
| | | electrical components | (all) | electrical components | (all) |
| | | compressors | (1 per type) | compressors | (all) |
| | | | | heat exchanger | (1 per type) |

17 TROUBLESHOOTING

| Symptom | Cooling | Heating | Who can take corrective action U = User S = specialised personnel | Probable cause | Possible remedy |
|----------------------------------------------------------------------------------------|---------|---------|-------------------------------------------------------------------------|--------------------------------------------------------------|------------------------------------------------------------------------------------------------------------------------------------------------------------------------------------------------------|
| A The unit does not start | X | X | S | Probe faulty service | Check and replace if necessary. |
| | X | X | S | Lack of consent of the high or low pressure | See points D-E |
| | X | X | S | Defective compressor | See point B. |
| B The compressor does not start | X | X | S | Compressor burnt or seized | Replace the compressor. |
| | X | X | S | Compressor contactor de-energized | Check the voltage across the coil of the compressor contactor and the continuity of the coil. |
| | X | X | S | Power circuit open | Investigate the cause of the protection, and check if there are any short circuits in the wiring or in the windings of the motors of pump, compressor and transformer |
| | X | X | S | Motor thermal protection open | The compressor has operated in critical condition or there is a lack of charge in the circuit: Make sure that working conditions are within the limits of operation. Loss of coolant: see section G. |
| C The compressor starts up and stops repeatedly | X | X | S | Intervention of the minimum | See point E. |
| | X | X | S | Compressor contactor defective | Check and replace if necessary. |
| | X | X | U | Calibration values of the set- point or differential | Modify them as reported in the in the tables. |
| | X | X | S | Lack of coolant | See point G |
| D The compressor does not start because the maximum pressure switch has tripped | X | X | S | Pressure switch out of order | Check and replace. |
| | X | X | S | Overcharge of refrigerant | Download the excess refrigerant |
| | | X | S | Water pump circulation blocked | Unblock the pump. |
| | | X | X | Water circulation pump and defective | Check and replace if necessary. |
| | X | X | S | Presence of non-condensable gases in the refrigerant circuit | Prime the circuit after it has been downloaded and put under vacuum. |
| | X | X | S | Refrigerant filter clogged | Check and replace. |

| Symptom | Cooling | Heating | Who can take corrective action U = User S = specialised personnel | Probable cause | Possible remedy |
|----------------------------------------------------------------------------------------|---------|---------|----------------------------------------------------------------------|-------------------------------------------------|--------------------------------------------------------------------------------------------------------------------------------------|
| E The compressor does not start because the minimum pressure switch has tripped | X | X | S | Pressure switch out of order | Check and replace. |
| | X | X | S | Machine completely void of refrigerant | See point G. |
| | X | | U | Water circulation pump blocked | Unlock the pump |
| | X | | S | Water circulation pump blocked and defective | Check the pump and replace if necessary |
| | | X | S | Presence of frost on the evaporator coil | See point N. |
| | X | X | S | Refrigerant filter clogged | Check and replace. |
| | X | X | S | Expansion device that is not working properly | Check and replace if necessary. |
| | X | X | S | Presence of moisture in the refrigerant circuit | Replace the filter, dry and recharge |
| G Lack of gas | X | X | S | Loss in the refrigerant circuit | Check the cooling circuit using a leak detector after pressurising the circuit to approximately 4 bars. Repair, evacuate and refill. |
| H Frost in the liquid line downstream from a filter | X | X | S | The filter is clogged | Replace the filter |
| I The unit works continuously without ever stopping | X | X | S | Lack of refrigerant gas | See item G. |
| | X | X | U | Incorrect tuning of the operating thermostat | Check and set. |
| | X | X | S | Excessive thermal load | Reduce the thermal load |
| | X | X | S | Compressor does not give the thermal output | Check, change or revise |
| | X | X | S | The liquid filter is clogged | Replace. |
| L The unit works regularly but with an insufficient capacity | X | X | S | Low refrigerant charge | See point G. |
| | X | X | S | 4-way reversing valve defective | Check the power supply and the coil of the valve and replace the valve |
| Symptom | Cooling | Heating | Who can take corrective action U = User S = specialised personnel | Probable cause | Possible remedy |
| M Frost in the compressor intake pipe | X | X | S | Expansion device that is not working properly | Verify and replace. |
| | X | X | S | Water circulation pump blocked | Unlock the pump. |

| | | | | | |
|------------------------------------------------|---|---|---|---------------------------------------|------------------------------------------|
| | X | X | S | Water circulation pump defective | Check the pump and replace if necessary. |
| | X | X | S | Low refrigerant charge | See point G. |
| | X | X | S | The liquid filter is clogged | Replace. |
| N Abnormal noise detected in the system | X | X | S | Compressor noisy | Check and replace if necessary. |
| | X | X | S | The panel vibrate | Fasten properly. |
| P The unit does not start | X | X | S | Phases of the supply network reversed | Invert two phases. |

18 IMPROPER USES

The unit is designed and built up to grant the maximum safety in its proximity.
Residual risks are indicated with warning labels.

SAFETY SYMBOLS



DANGER:
General danger

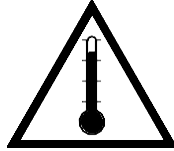

DANGER:
Temperature

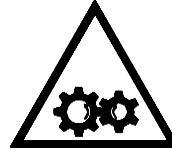

DANGER:
Moving parts



DANGER:
Cutoff voltage

Trane - by Trane Technologies (NYSE: TT), a global climate innovator - creates comfortable, energy efficient indoor environments for commercial and residential applications. For more information, please visit trane.eu or tranetechnologies.com.

Trane has a policy of continuous product and product data improvement and reserves the right to change design and specifications without notice.

Confidential and proprietary Trane information

CG-SVX050E -GB_1023
Supersedes CG-SVX050D-GB_0323

©2023 Trane