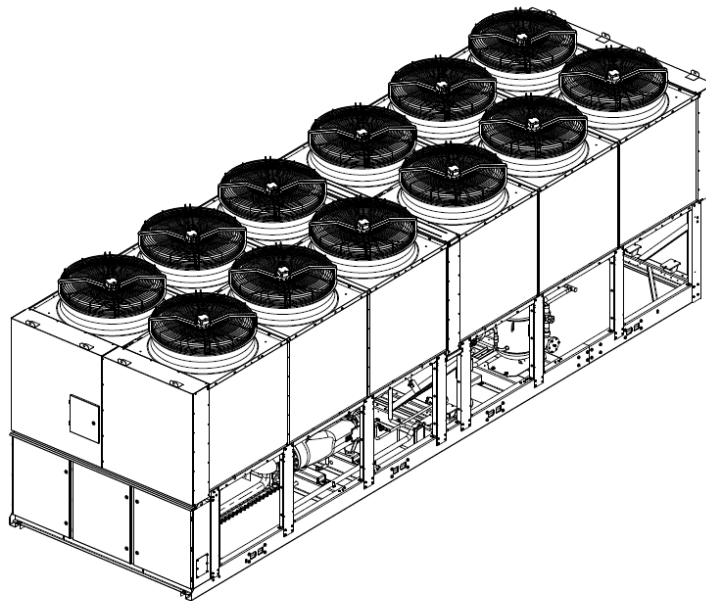




# Installation, Operation and Maintenance

## RTXC-XE series Air-Cooled Screw Chiller Heat Pump



572568050001

### **⚠ SAFETY WARNING**

Only qualified personnel should install and service the equipment. The installation, starting up, and servicing of heating, ventilating, and air-conditioning equipment can be hazardous and requires specific knowledge and training. Improperly installed, adjusted, or altered equipment by an unqualified person could result in death or serious injury. When working on the equipment, observe all precautions in the literature and on the tags, stickers, and labels that are attached to the equipment.

July 2023

RTXC-SVX003D-EN



Confidential and proprietary Trane information



## Warnings, Cautions, and Notices

This document is customer property and is to remain with this unit. Only trained and qualified service personnel should install, repair, or service air-conditioning equipment. Read this manual thoroughly before startup and follow installation and service requirements to assure unit reliable operation. This manual does not contain all service procedures necessary for the continued successful operation of this equipment. For more information, contact your local agent.

Warnings, Cautions, and Notices appear at appropriate sections throughout this literature. Read and follow these carefully.

### **⚠ WARNING**

Indicates a potentially hazardous situation which, if not avoided, could result in death or serious injury.

### **⚠ CAUTION**

Indicates a potentially hazardous situation which, if not avoided, could result in minor or moderate injury. It may also be used to alert against unsafe practices.

### **NOTICE**

Indicates a situation that could result in equipment or property-damage only accidents.

## Important

### Responsible Refrigerant Practices

Trane believes that responsible refrigerant practices are important to the environment, our customers, and the air conditioning industry. All technicians who handle refrigerants must be certified. Know and follow the applicable laws for handling, reclaiming, recovering, and recycling of certain refrigerants and the equipment used in these service procedures.

### **⚠ WARNING**

#### **Contains Refrigerant!**

System contains oil and refrigerant under high pressure. Recover refrigerant to relieve pressure before opening the system. See unit nameplate for refrigerant type. Do not use non-approved refrigerants, refrigerant substitutes, or refrigerant additives. Failure to follow proper procedures or the use of non-approved refrigerants, refrigerant substitutes, or refrigerant additives could result in death or serious injury or equipment damage.

### **⚠ WARNING**

#### **Personal Protective Equipment (PPE) Required!**

Always refer to appropriate guidelines when handling refrigerants. Use proper breathing, eye, and body protection during the handling of refrigerants. Failure to follow proper handling guidelines could result in death or serious injury.

### **⚠ WARNING**

#### **Live Electrical Components!**

During installation, testing, servicing, and troubleshooting of this product, it may be necessary to work with live electrical components. Have a qualified licensed electrician or other individual who has been properly trained in handling live electrical components perform these tasks. Failure to follow all electrical safety precautions when exposed to live electrical components could result in death or serious injury.



## Installation Completion and Request for Trane Service

**Important:** A copy of this completed form must be submitted to the Trane Service Agency that will be responsible for the start-up of the equipment. Start-up will NOT proceed unless applicable items listed in this form have been satisfactorily completed.

TO: \_\_\_\_\_  
Trane SERVICE OFFICE: \_\_\_\_\_  
S.O. NUMBER: \_\_\_\_\_  
SERIAL NUMBERS: \_\_\_\_\_  
JOB/PROJECT NAME: \_\_\_\_\_  
ADDRESS: \_\_\_\_\_

### The following items are being installed and will be completed by:

**Important:** Start-up must be performed by Trane, or an agent of Trane specifically authorized to perform start-up and warranty of Trane® products. Contractor shall provide Trane (or an agent of Trane specifically authorized to perform start-up) with notice of the scheduled start-up **at least two weeks** prior to the scheduled start-up. **Equipment not started by Trane is not warranted by Trane.**

Check box if the task is complete or if the answer is "yes"

#### Unit location

- Provide enough space around unit to allow unobstructed air flow
- Unit mounting placed on a rigid and level foundation
- Isolator installed and fully tightened
- Secure no external vibration transmitted to the unit
- Provide enough space around unit for installation and service personnel unrestricted access

#### Wiring

- Wiring size per all national or local codes and equipped with the remote fused disconnect switches
- Inspect all wiring connections to ensure correct and tight
- Ground all customer supplied power wires as required by applicable codes
- Distance between low voltage line and power wiring meet required
- Check wiring connections corrected and tightened before power on
- Provide separately power for anti-freeze heater of evaporator, PHR BPHE or water pipes

#### Piping

- Water system designed by professional designers, such as piping diameter etc.
- Water pump head match actual water side resistance
- Water strainer installed before inlet of the unit and cleaned prior to connection
- Water pressure gauges installed with shutoff valves to monitor evaporator pressure drop
- Vibration eliminators equipped to prevent vibration transmission through the water pipes
- Air vent, drain and feed valve at the right position of water system
- Meet minimum water loop volume of 9 liter/kW to stable leaving water temperature for comfort cooling
- Thoroughly flush all external water piping before final piping connecting to the unit
- Pass water system pressurization test and no water leakage identified
- Water system filled and air bled from system
- Anti-freeze protection active after water system filled in winter
- Flow switch installed (if not factory-provided)
- External interlocks (flow switch, pumps auxiliary, etc.) per Wiring Schematics of the manual
- Water piping insulated and fixed
- Evaporator bypass valve installed as required (if installed)



## Installation Completion and Request for Trane Service

### Power Supply

- Voltage must be within the utilization range of the unit nameplate and imbalance must not exceed 2%
- Power supply should not be temporarily provided
- Power phase sequence correct
- Owner or representative should participate the commissioning
- Enough equipment support, like ladder, elevating platforms, etc. for the commissioning personnel
- Oil sump heaters operated at least 12 hours before starting
- Measure and check the oil sump level within allowable range before startup (if necessary)

### Test

- Dry nitrogen available for pressure testing (if necessary)

### Refrigerant

- Refrigerant on job site and in close proximity to unit (if shipped separately)

**Note:** After commissioning is complete, it is the installer's responsibility to transport empty refrigerant containers to an easily accessible point of loading to facilitate container return or recycling.

### System

- Systems can be operated under all design selection points to verify proper operation.

**Note:** Additional time required to properly complete the start-up and commissioning, due to any incompleteness of the installation, will be invoiced at prevailing rates.

This is to certify that the Trane equipment has been properly and completely installed, and that the applicable items listed above have been satisfactorily completed.

### Checklist Completed by

(Print Name):

SIGNATURE:

DATE:

In accordance with your quotation and our purchase order number \_\_\_\_\_, we therefore require the presence of Trane service on this site, for the purpose of start-up and commissioning, by \_\_\_\_\_ (date).

**Note:** Minimum of two-week advance notification is required to allow for scheduling of unit start-up.

ADDITIONAL COMMENTS/INSTRUCTIONS

**Note:** A copy of this completed form must be submitted to the Trane Service Agency that will be responsible for start-up of equipment.

# Contents

<b>Warnings, Cautions, and Notices .....</b>	<b>2</b>
Important .....	2
<b>Model Number Descriptions .....</b>	<b>8</b>
<b>General Information.....</b>	<b>9</b>
Warranty.....	9
Unit Description.....	9
Reception .....	9
Storage.....	10
Nameplate.....	10
<b>General Data .....</b>	<b>11</b>
General Data – XE with AC Fan – R134a .....	11
General Data – XE with EC Fan – R134a.....	12
General Data – XE with EC Fan – R513A .....	13
General Data – XE-HSE with EC Fan – R134a .....	14
General Data – XE-HSE with EC Fan – R513A.....	15
<b>Installation Requirements .....</b>	<b>16</b>
Contractor Responsibilities.....	16
Location Requirements .....	16
Rigging .....	18
Neoprene Isolator Installation .....	20
Cover Plate of Assembly Unit Installation .....	23
Water Piping .....	23
Partial Heat Recovery Piping .....	29
Partial Heat Recovery Freeze Avoidance.....	30
<b>Electrical Controls .....</b>	<b>31</b>
General Recommendations .....	31
Starter Panel .....	32
Power Supply Wiring.....	33
Heater Power Supply .....	33
Unit Water Pump Control .....	33
Partial Heat Recovery Heater Power Supply .....	34
Alarm and Status Relay Outputs (Programmable Relays) – Optional.....	35
Emergency Stop .....	35
External Auto/Stop .....	35
Heating/Cooling Mode Setting .....	35
External Current Limit Setpoint .....	36
External Chilled/Hot Water Setpoint.....	36
Building Automation Control System Communication Interface.....	36
Master-Slave Unit Wiring Connection.....	37
<b>Operator Interface Controls .....</b>	<b>38</b>

Symbio800 Overview .....	38
TracerTU .....	39
<b>Operating Principles .....</b>	<b>40</b>
General.....	40
Refrigerant .....	40
Compressor .....	40
Oil Filter.....	41
Air Side Heat Exchanger .....	41
Water Side Heat Exchanger .....	41
Economizer (Only for RTX110/180/220XE, 110/180/220/250/280XE-HSE) .....	41
Expansion Valve.....	41
Oil Separator.....	41
Fan.....	42
Oil Circuit.....	42
Receiver.....	42
Partial Heat Recovery Option.....	42
RTXC-XE/XE-HSE Operating Map .....	43
<b>Pre-Start Checkout.....</b>	<b>44</b>
Prestart procedures .....	44
Unit Voltage Power Supply .....	46
Unit Voltage Imbalance .....	47
Unit Voltage Phasing .....	47
Water System Flow Rates .....	48
Water System Pressure Drop.....	48
<b>Unit Start-up and Shut-down Procedures.....</b>	<b>49</b>
Sequence of Operation .....	49
Unit Startup .....	49
Unit Shutdown.....	50
Seasonal Unit Start-up.....	51
<b>Periodic Maintenance .....</b>	<b>52</b>
<b>Maintenance and Service .....</b>	<b>55</b>
Refrigerant Field Charge Procedure .....	55
Refrigerant Field Charge to an Undercharged Unit .....	55
Refrigerant Recycling .....	55
Refrigerant Filter Replacement Procedure .....	56
Compressor Oil.....	56
Fin-tube Coil Cleaning .....	57
Water Side Heat Exchanger Maintenance .....	57
<b>AC Drive (Only for RTX-XE-HSE) .....</b>	<b>60</b>
AC Drive Programming.....	60
Product Information .....	60
Product Appearance and Dimensions.....	62
Technical Specifications.....	63
Standard Wiring.....	64
Main Circuit Terminals .....	65

Operating Panel Introduction .....	67
Keys on LED Operating Panel .....	67
Function Indicators.....	68
Troubleshooting- Fault Display and Reset .....	68
Troubleshooting- Faults and Diagnostics.....	69
Symptoms and Diagnostics.....	73
Function Code.....	74



# Model Number Descriptions

R T X C 1 1 0 D X A 0 1 C N N A R N 0 D 0 N 0 N D F D  
 1 2 3 4 5 6 7 8 9 10 11 12 13 14 15 16 17 18 19 20 21 22 23 24 25 26 27

Digit 1-4	Model: RTXC Air-cooled Screw Heat Pump	Digit 17	Installation Accessories
Digit 5-7	Nominal Tonnage (Note: * indicate not available now)		N = None
	110 = 110 tons    280 = 280 tons	Digit 18	R = Neoprene Isolators
	130 = 130 tons    *310 = 310 tons		Flow Switch
	140 = 140 tons    *330 = 330 tons		N = None
	160 = 160 tons    *360 = 360 tons	Digit 19	F = Field Installed Flow Switch
	180 = 180 tons    *400 = 400 tons		Additional Options
	200 = 200 tons    *440 = 440 tons		0 = Standard Configuration
	220 = 220 tons    *500 = 500 tons	Digit 20	C = With Protection Panel
	250 = 250 tons    *560 = 560 tons		Relief Valve Option
Digit 8	Unit Power Supply		S = Single Relief Valve
	D = 400V/50Hz/3Ph	Digit 21	D = Dual Relief Valve With 3 Way Valve
Digit 9	Efficiency		Evap Bypass Valve Control
	X = High Efficiency XE		0 = No Evaporator Bypass Control
	H = High Seasonal Efficiency HSE	Digit 22	A = With Evap Bypass Control Function
Digit 10-11	Design Sequence		Heat Recovery
	A0 = Factory Assigned		N = No Heat Recovery
Digit 12	Incoming Power Line	Digit 23	P = Partial Heat Recovery
	1 = Single Point Power Connection		Compressor Sound Box
	2 = Dual Point Power Connection		0 = No Compressor Sound Box
Digit 13	Power Line Connection Type	Digit 24	S = With Compressor Sound Box
	C = Circuit Breaker		Fin Coil Coating
	D = Mechanical Disconnect Switch		N = No Fin Coil Coating
Digit 14	BAS Communication Interface	Digit 25	Factory Charge
	N = No Remote Interface (Default)		D = Nitrogen Charge - R134a Field Supplied
	B = BACnet Communication Interface	Digit 26	F = Nitrogen Charge - R513A Field Supplied
	M = Modbus Communication Interface		Fan Type
	L = LonTalk Communication Interface		F = AC Fixed Speed Fans
Digit 15	External Water & Current Limit Setpoint	Digit 27	E = EC Condenser Fan Motors
	N = No External Setpoint Input		Pump Control
	R = External Leaving WaterTemp Setpoint		N = No Dual-Pump Control
	C = External Current Limit Setpoint		D = Dual-Pump Power Supply
	B = External Leaving WaterTemp & External Current Limit Setpoint		
Digit 16	Programmable Relays		
	N = No Programmable Relays		
	A = With Programmable Relays		





# General Information

## Warranty

Warranty is based on the general terms and conditions of Trane. The warranty is void if the equipment is repaired or modified without the written approval of the manufacturer if the operating limits are exceeded or if the control system or the electrical wiring is modified. Damage due to misuse, lack of maintenance or failure to comply with the manufacturer's instructions or recommendations is not covered by the warranty obligation. If the user does not conform to the rules of this manual, it may entail cancellation of warranty and liabilities by the manufacturer.

## Unit Description

RTXC-XE high efficiency range includes 10 unit sizes 110, 160, 180, 200, 220, 310, 330, 360, 400 and 440XE with partial heat recovery (PHR) option. RTXC-XE-HSE (High Seasonal Efficiency) has 16 sizes, 10 sizes of them are the same as RTXC-XE and adds 6 sizes of 130, 140, 250, 280, 500, 560XE-HSE by rising VFD output frequency. The 110, 130, 140, 160, 180, 200, 220, 250, 280 models are independent units with single water-side heat exchanger, the 310, 330, 360, 400, 440, 500, 560 models are installed by the customer on site.

The 310XE/XE-HSE, 330XE/XE-HSE, 360XE/XE-HSE, 400XE/XE-HSE and 440XE/XE-HSE, 500XE-HSE, 560XE-HSE are formed by a combination of two units as followed:

Unit Name	XE/XE-HSE					XE-HSE	
	310	330	360	400	440	500	560
Unit 1 (Master)	200	220	200	200	220	250	280
Unit 2 (Slave)	110	110	160	200	220	250	280

The unit features twin-rotor screw compressor, high-efficiency fin-tube air-side heat exchanger, Trane patented falling film water-side heat exchanger, BPHE economizer, optional hot water side BPHE for partial heat recovery function and Trane exclusive Symbio 800 control. The 110, 130, 140, 160, 180, 200, 220, 250, 280 models have already completed all the assembly and test work before shipment to ensure each unit providing chilled /heated water efficiently and reliably. The 310, 330, 360, 400, 440, 500, 560 models will be installed by the customer on-site for parallel connection of water pipes, as well as the electric control wiring and setting, refer to "[Master-Slave Unit Wiring Connection](#)" part of this manual.

## Reception

To protect against loss due to damage incurred in transit, complete the following checklist upon receipt of the unit.

- When the unit is delivered, verify that it is the correct unit and that it is properly equipped. Compare the information which appears on the unit nameplate with the ordering and submittal information. Check if the model number of unit nameplate consistent with the order. Refer to "[Nameplate](#)".
- Inspect all exterior components for visible damage. Report any apparent damage or material shortage to the carrier and make a "unit damage" notation on the carrier's delivery receipt. Specify the extent and type of damage found and notify the appropriate Trane Sales Office.
- Inspect the unit for concealed damage as soon as possible after delivery and before it is stored. Concealed damage must be reported within 15 days.
  - If concealed damage is discovered, stop unpacking the shipment. Do not remove damaged material from the receiving location. Take photos of the damage, if possible. The owner must provide reasonable evidence that the damage did not occur after delivery.
  - Notify the carrier's terminal of the damage immediately, by phone and by mail. Request an immediate, joint inspection of the damage with the carrier and the consignee. Notify the Trane sales representative and arrange for repair. Do not repair the unit, however, until damage is inspected by the carrier's representative. Do not proceed with installation of a damaged unit without Trane sales office approval.
- Check all the accessories and loose parts which are shipped with the unit against the original order. Included in these items will be water vessel drain plugs, rigging diagrams, electrical diagrams, and service literature, which are placed inside the control panel for shipment. Also

check for optional components, such as flow switches and isolators. If optional isolators are ordered, they are shipped mounted on the base of the unit. Notify any apparent damage or material shortage to the carrier and Trane local offices.

## Storage

Extended storage of the unit prior to installation requires the following precautions:

Store the unit in a ventilated, dry, and secure area. Allowed environmental temperature to range from -25°C to 60°C.

At least every three months, attach a gauge and manually check the pressure in the refrigerant circuit to verify no refrigerant charge leakage. If the refrigerant leakage occurred, call a qualified service organization and the appropriate Trane sales office.

**Note:** Pressure will be approximately 200kPa gauge (29 psig) if shipped with a refrigerant “waiting charge.”

## Nameplate


The RTX-C-XE/XE-HSE unit nameplates are applied to the exterior surface of the top cover above the control panel door. A compressor nameplate is located on each compressor. The evaporator nameplate is located on the shell. And the insulation over the nameplates is intentionally left unglued, for ease in viewing the nameplate. The receiver and oil separator nameplates are on their shells respectively.

## Unit Nameplate

The unit nameplate provides the following information:

- Unit model number
- Unit serial number
- Unit nominal cooling, heating capacity
- Quantity of compressor, fans
- Unit electrical requirements and input power
- Correct operating charges of refrigerant and oil
- Unit shipping weight
- Unit dimension

**Figure 1. Unit Nameplate**

		AIR-COOLED SCREW CHILLER HEAT PUMP		CE
		RTXC-XE SERIES		
MODEL NO.	<input type="text"/>	EEL MODEL	<input type="text"/>	
CLASSIFICATION	<input type="text"/>	SERIAL No.	<input type="text"/>	
COOLING CAPACITY	<input type="text"/> kW	HEATING CAPACITY	<input type="text"/> kW	
MAXIMUM STARTING CURRENT	<input type="text"/> A			
SHORT CIRCUIT CURRENT RATING	<input type="text"/> kA			
MAXIMUM OPERATING CURRENT	<input type="text"/> A			
MAXIMUM OPERATING POWER	<input type="text"/> kW			
PS LP	<input type="text"/> bar	HP	<input type="text"/> bar	
RATED VOLTAGE	<input type="text"/> V	RATED FREQUENCY	<input type="text"/> Hz	
PHASE	<input type="text"/>	REFRIGERANT CHARGE	<input type="text"/> kg	
REFRIGERANT	<input type="text"/>	REFRIGERANT GWP	<input type="text"/>	
WEIGHT	<input type="text"/> kg	OIL CHARGE	<input type="text"/> L	
DIMENSION	<input type="text"/> mm		ELECTRICAL SCHEMATIC	<input type="text"/>
SERVICE MODEL NO.	<input type="text"/>		MANUFACTURE DATE	<input type="text"/>
<small>TRANE AIR CONDITIONING SYSTEMS (CHINA) CO., LTD. No.88 East Suzhou Road, Taicang, 215400 Jiangsu, P.R. China</small>				
<small>57256804</small>				



# General Data

## General Data – XE with AC Fan – R134a

		110	160	180	200	220
<b>Cooling <sup>(1)</sup></b>						
Total Cooling Capacity	kW	383	583	640	679	753
Energy Efficiency Rating (EER)		3.39	3.51	3.38	3.38	3.34
Energy efficiency class (Eurovent)		A	A	A	A	A
Space Cooling Efficiency $\eta_{s,c}$	%	175	184	184	179	179
SEER		4.46	4.68	4.67	4.55	4.55
Sound Power – STD Noise <sup>(2)</sup>	dB(A)	100	102	103	102	103
Sound Pressure – STD Noise (1m)	dB(A)	80	80	82	80	81
Sound Power – Low Noise <sup>(2)</sup>	dB(A)	98	100	101	100	101
Sound Pressure – Low Noise (1m)	dB(A)	78	78	80	78	79
Water Flow Rate	l/s	18.2	27.8	30.6	32.3	35.9
Pressure Drop	kPa	65	44	45	51	63
Water Pipe Connection	mm	DN100	DN150	DN150	DN150	DN150
<b>Heating <sup>(3)</sup></b>						
Total Heating Capacity	kW	386	552	645	665	766
Coefficient Of Performance (COP)		3.47	3.41	3.50	3.23	3.35
Energy efficiency class (Eurovent)		A	A	A	A	A
P <sub>design, h</sub>	kW	289	362	485	450	532
Space Heating Efficiency $\eta_{s,h}$	%	126	134	132	125	129
SCOP		3.22	3.42	3.38	3.20	3.31
Water Flow Rate	l/s	18.6	26.7	30.8	32.2	37.0
Pressure Drop	kPa	66	38	46	50	66
<b>Compressor</b>						
Type		Semi-Hermetic Twin Screw Compressor				
Number of Compressors		1	2	2	2	2
Number of Circuit		1	2	2	2	2
Minimum Load	%	30	15	15	15	15
<b>Refrigerant</b>						
<b>R134a</b>						
Refrigerant Charge	kg	175	310	310	350	350
Oil Charge	kg	10	20	20	20	20
<b>Electrical</b>						
Max Starting Amps	A	405	585	585	654	654
Max Operating Amps	A	251	425	425	499	499
Max Starting Amps w/ Pump Control	A	417	610	610	679	679
Max Operating Amps w/ Pump Control	A	263	450	450	524	524
<b>Dimensions &amp; Weight (Basic Model Only)</b>						
Length	mm	4300	7700	7700	8700	8700
Width	mm	2250	2250	2250	2250	2250
Height	mm	2500	2500	2500	2500	2500
Operating Weight	kg	4220	7020	7140	7501	7621

(1). According EN 14511:2018 & EN 14825:2018, Outdoor air temperature 35°C – Chilled water temperature 12/7°C.

(2). According ISO 9614:2009. Eurovent conditions, with 1pW reference sound power. STD=Standard Configuration. Low=w/ Compressor Sound Box.

(3). According EN 14511:2018. Outdoor air temperature 7°C with 6°C wet (87% RH) - Hot water temperature 40/45 °C.



## General Data – XE with EC Fan – R134a

		110	160	180	200	220
<b>Cooling <sup>(1)</sup></b>						
Total Cooling Capacity	kW	385	587	643	684	758
Energy Efficiency Rating (EER)		3.49	3.57	3.44	3.44	3.40
Energy efficiency class (Eurovent)		A	A	A	A	A
Space Cooling Efficiency $\eta_{s,c}$	%	180	188	189	185	184
SEER		4.58	4.78	4.81	4.70	4.67
Sound Power – STD Noise <sup>(2)</sup>	dB(A)	101	102	104	102	104
Sound Pressure – STD Noise (1m)	dB(A)	81	81	82	81	82
Sound Power – Low Noise <sup>(2)</sup>	dB(A)	99	101	102	101	102
Sound Pressure – Low Noise (1m)	dB(A)	79	80	80	79	80
Water Flow Rate	l/s	18.4	28.0	30.7	32.7	36.2
Pressure Drop	kPa	66	44	53	52	64
Water Pipe Connection	mm	DN100	DN150	DN150	DN150	DN150
<b>Heating <sup>(3)</sup></b>						
Total Heating Capacity	kW	388	555	648	668	770
Coefficient Of Performance (COP)		3.53	3.45	3.53	3.25	3.37
Energy efficiency class (Eurovent)		A	A	A	A	A
Pdesign, h	kW	269	382	452	467	535
Space Heating Efficiency $\eta_{s,h}$	%	128	136	132	130	128
SCOP		3.29	3.48	3.37	3.33	3.29
Water Flow Rate	l/s	18.5	26.5	31.0	31.9	36.8
Pressure Drop	kPa	67	39	51	51	67
<b>Compressor</b>						
Type		Semi-Hermetic Twin Screw Compressor				
Number of Compressors		1	2	2	2	2
Number of Circuit		1	2	2	2	2
Minimum Load	%	30	15	15	15	15
<b>Refrigerant</b>						
<b>R134a</b>						
Refrigerant Charge	kg	175	310	310	350	350
Oil Charge	kg	10	20	20	20	20
<b>Electrical</b>						
Max Starting Amps	A	404	583	583	652	652
Max Operating Amps	A	250	423	423	497	497
Max Starting Amps w/ Pump Control	A	416	608	608	677	677
Max Operating Amps w/ Pump Control	A	262	448	448	522	522
<b>Dimensions &amp; Weight (Basic Model Only)</b>						
Length	mm	4300	7700	7700	8700	8700
Width	mm	2250	2250	2250	2250	2250
Height	mm	2500	2500	2500	2500	2500
Operating Weight	kg	4220	7020	7140	7501	7621

(1). According EN 14511:2018 & EN 14825:2018, Outdoor air temperature 35°C – Chilled water temperature 12/7°C.

(2). According ISO 9614:2009. Eurovent conditions, with 1pW reference sound power. STD=Standard Configuration. Low=w/ Compressor Sound Box.

(3). According EN 14511:2018. Outdoor air temperature 7°C with 6°C wet (87% RH) - Hot water temperature 40/45 °C.



## General Data – XE with EC Fan – R513A

		110	160	180	200	220
<b>Cooling <sup>(1)</sup></b>						
Total Cooling Capacity	kW	373	550	640	665	736
Energy Efficiency Rating (EER)		3.12	3.18	3.23	3.17	3.09
Energy efficiency class (Eurovent)		A	A	A	A	A
Space Cooling Efficiency $\eta_{s,c}$	%	172	183	179	181	179
SEER		4.36	4.66	4.55	4.60	4.55
Sound Power – STD Noise <sup>(2)</sup>	dB(A)	101	102	104	102	104
Sound Pressure – STD Noise (1m)	dB(A)	81	81	82	81	82
Sound Power – Low Noise <sup>(2)</sup>	dB(A)	99	101	102	101	102
Sound Pressure – Low Noise (1m)	dB(A)	79	80	80	79	80
Water Flow Rate	l/s	17.8	26.3	30.6	31.8	35.2
Pressure Drop	kPa	62	39	53	49	60
Water Pipe Connection	mm	DN100	DN150	DN150	DN150	DN150
<b>Heating <sup>(3)</sup></b>						
Total Heating Capacity	kW	397	549	644	673	798
Coefficient Of Performance (COP)		3.30	3.18	3.24	3.10	3.17
Energy efficiency class (Eurovent)		A	A	A	A	A
Pdesign, h	kW	284	394	459	484	574
Space Heating Efficiency $\eta_{s,h}$	%	132	135	131	135	135
SCOP		3.37	3.46	3.35	3.44	3.44
Water Flow Rate	l/s	18.9	26.2	30.8	32.1	38.1
Pressure Drop	kPa	70	38	50	51	71
<b>Compressor</b>						
Type		Semi-Hermetic Twin Screw Compressor				
Number of Compressors		1	2	2	2	2
Number of Circuit		1	2	2	2	2
Minimum Load	%	30	15	15	15	15
<b>Refrigerant</b>				<b>R513A</b>		
Refrigerant Charge	kg	172	304	304	344	344
Oil Charge	kg	10	20	20	20	20
<b>Electrical</b>						
Max Starting Amps	A	404	583	583	652	652
Max Operating Amps	A	250	423	423	497	497
Max Starting Amps w/ Pump Control	A	416	608	608	677	677
Max Operating Amps w/ Pump Control	A	262	448	448	522	522
<b>Dimensions &amp; Weight (Basic Model Only)</b>						
Length	mm	4300	7700	7700	8700	8700
Width	mm	2250	2250	2250	2250	2250
Height	mm	2500	2500	2500	2500	2500
Operating Weight	kg	4220	7020	7140	7501	7621

(1). According EN 14511:2018 & EN 14825:2018, Outdoor air temperature 35°C – Chilled water temperature 12/7°C.

(2). According ISO 9614:2009. Eurovent conditions, with 1pW reference sound power. STD=Standard Configuration. Low=w/ Compressor Sound Box.

(3). According EN 14511:2018. Outdoor air temperature 7°C with 6°C wet (87% RH) - Hot water temperature 40/45 °C.



## General Data – XE-HSE with EC Fan – R134a

		110	130	140	160	180	200	220	250	280
<b>Cooling <sup>(1)</sup></b>										
Total Cooling Capacity	kW	381	438	481	585	647	692	753	865	948
Energy Efficiency Rating (EER)		3.20	3.06	2.86	3.29	3.24	3.24	3.19	3.04	2.87
Energy efficiency class (Eurovent)		A	A	A	A	A	A	A	A	A
Space Cooling Efficiency $\eta_{s,c}$	%	206	203	199	215	219	219	214	209	204
SEER		5.23	5.15	5.06	5.45	5.54	5.54	5.42	5.30	5.17
Sound Power – STD Noise <sup>(2)</sup>	dB(A)	101	105	102	102	104	102	104	108	105
Sound Pressure – STD Noise (1m)	dB(A)	80	84	82	81	82	81	82	86	83
Sound Power – Low Noise <sup>(2)</sup>	dB(A)	99	102	100	101	102	101	102	105	103
Sound Pressure – Low Noise (1m)	dB(A)	79	82	80	79	80	79	80	83	81
Water Flow Rate	l/s	17.7	20.4	22.3	27.3	26.9	31.5	35.0	40.2	44.0
Pressure Drop	kPa	61	81	98	42	42	48	60	80	96
Water Pipe Connection	mm	DN100	DN100	DN100	DN150	DN150	DN150	DN150	DN150	DN150
<b>Heating <sup>(3)</sup></b>										
Total Heating Capacity	kW	384	439	472	561	634	668	762	876	943
Coefficient Of Performance (COP)		3.33	3.21	3.19	3.34	3.33	3.18	3.19	3.06	3.02
Energy efficiency class (Eurovent)		A	A	A	A	A	A	A	A	A
Pdesign, h	kW	206	237	248	298	337	357	408	471	512
Space Heating Efficiency $\eta_{s,h}$	%	139	138	136	144	149	140	135	134	125
SCOP		3.54	3.53	3.48	3.68	3.81	3.57	3.45	3.43	3.20
Water Flow Rate	l/s	18.1	20.7	22.1	26.4	26.7	31.1	36.0	41.3	43.9
Pressure Drop	kPa	63	81	91	37	39	47	62	81	90
<b>Compressor</b>										
Type		Semi-Hermetic Twin Screw Compressor								
Number of Compressors		1	1	1	2	2	2	2	2	2
Number of Circuit		1	1	1	2	2	2	2	2	2
Minimum Load	%	30	30	30	15	15	15	15	15	15
<b>Refrigerant <span style="float: right;">R134a</span></b>										
Refrigerant Charge	kg	175	175	175	310	310	350	350	350	350
Oil Charge	kg	10	10	10	20	20	20	20	20	20
<b>Electrical</b>										
Max Starting Amps	A	213	255	255	392	392	461	461	553	553
Max Operating Amps	A	252	302	302	425	425	499	499	600	600
Max Starting Amps w/ Pump Control	A	225	267	267	417	417	486	486	578	578
Max Operating Amps w/ Pump Control	A	264	314	314	450	450	524	524	625	625
<b>Dimensions &amp; Weight (Basic Model Only)</b>										
Length	mm	4720	4720	4720	7900	7900	8900	8900	8900	8900
Width	mm	2250	2250	2250	2250	2250	2250	2250	2250	2250
Height	mm	2500	2500	2500	2500	2500	2500	2500	2500	2500
Operating Weight	kg	4344	4396	4396	7251	7371	7759	7879	7965	7965

(1). According EN 14511:2018 & EN 14825:2018, Outdoor air temperature 35°C – Chilled water temperature 12/7°C.

(2). According ISO 9614:2009. Eurovent conditions, with 1pW reference sound power. STD=Standard Configuration. Low=w/ Compressor Sound Box.

(3). According EN 14511:2018. Outdoor air temperature 7°C with 6°C wet (87% RH) - Hot water temperature 40/45 °C.



## General Data – XE-HSE with EC Fan – R513A

		110	130	140	160	180	200	220	250	280
<b>Cooling <sup>(1)</sup></b>										
Total Cooling Capacity	kW	372	429	463	549	607	669	736	817	915
Energy Efficiency Rating (EER)		2.90	2.84	2.36	2.93	2.88	2.97	2.88	2.86	2.35
Energy efficiency class (Eurovent)		A	A	A	A	A	A	A	A	A
Space Cooling Efficiency $\eta_{s,c}$	%	186	182	176	195	199	206	193	188	179
SEER		4.72	4.62	4.47	4.95	5.04	5.21	4.90	4.78	4.55
Sound Power – STD Noise <sup>(2)</sup>	dB(A)	101	105	102	102	104	102	104	108	105
Sound Pressure – STD Noise (1m)	dB(A)	80	84	82	81	82	81	82	86	83
Sound Power – Low Noise <sup>(2)</sup>	dB(A)	99	102	100	101	102	101	102	105	103
Sound Pressure – Low Noise (1m)	dB(A)	79	82	80	79	80	79	80	83	81
Water Flow Rate	l/s	17.3	19.9	21.5	26.0	26.0	30.4	34.2	39.4	42.5
Pressure Drop	kPa	58	78	91	37	37	45	57	77	89
Water Pipe Connection	mm	DN100	DN100	DN100	DN150	DN150	DN150	DN150	DN150	DN150
<b>Heating <sup>(3)</sup></b>										
Total Heating Capacity	kW	400	456	503	549	619	699	803	891	1027
Coefficient Of Performance (COP)		3.17	3.09	2.88	2.98	2.96	3.11	3.06	3.03	2.75
Energy efficiency class (Eurovent)		A	A	A	A	A	A	A	A	A
Pdesign, h	kW	222	248	277	302	341	386	447	493	567
Space Heating Efficiency $\eta_{s,h}$	%	138	139	134	133	135	142	133	135	130
SCOP		3.52	3.55	3.43	3.40	3.46	3.62	3.40	3.44	3.33
Water Flow Rate	l/s	18.7	21.4	23.7	25.6	26.9	32.4	37.7	43.5	48.4
Pressure Drop	kPa	67	86	104	36	38	51	68	89	108
<b>Compressor</b>										
Type		Semi-Hermetic Twin Screw Compressor								
Number of Compressors		1	1	1	2	2	2	2	2	2
Number of Circuit		1	1	1	2	2	2	2	2	2
Minimum Load	%	30	30	30	15	15	15	15	15	15
<b>Refrigerant</b>										
		<b>R513A</b>								
Refrigerant Charge	kg	172	172	172	304	304	344	344	344	344
Oil Charge	kg	10	10	10	20	20	20	20	20	20
<b>Electrical</b>										
Max Starting Amps	A	213	255	255	392	392	461	461	553	553
Max Operating Amps	A	252	302	302	425	425	499	499	600	600
Max Starting Amps w/ Pump Control	A	225	267	267	417	417	486	486	578	578
Max Operating Amps w/ Pump Control	A	264	314	314	450	450	524	524	625	625
<b>Dimensions &amp; Weight (Basic Model Only)</b>										
Length	mm	4720	4720	4720	7900	7900	8900	8900	8900	8900
Width	mm	2250	2250	2250	2250	2250	2250	2250	2250	2250
Height	mm	2500	2500	2500	2500	2500	2500	2500	2500	2500
Operating Weight	kg	4344	4396	4396	7251	7371	7759	7879	7965	7965

(1). According EN 14511:2018 & EN 14825:2018, Outdoor air temperature 35°C – Chilled water temperature 12/7°C.

(2). According ISO 9614:2009. Eurovent conditions, with 1pW reference sound power. STD=Standard Configuration. Low=w/ Compressor Sound Box.

(3). According EN 14511:2018. Outdoor air temperature 7°C with 6°C wet (87% RH) - Hot water temperature 40/45 °C.



# Installation Requirements

## Contractor Responsibilities

Table 1. Contractor Responsibilities

Type of Requirement	Trane Supplied Trane Installed	Trane Supplied Field Installed	Field Supplied Field Installed
Foundation			<ul style="list-style-type: none"> <li>Meet foundation requirements</li> </ul>
Rigging			<ul style="list-style-type: none"> <li>Safety chains, Clevis connectors, Lifting beam</li> </ul>
Isolation		<ul style="list-style-type: none"> <li>Neoprene Isolators (Optional)</li> </ul>	<ul style="list-style-type: none"> <li></li> </ul>
Electrical	<ul style="list-style-type: none"> <li>Mechanical Disconnect Switch or Circuit Breaker</li> <li>Unit-mounted starter</li> </ul>		<ul style="list-style-type: none"> <li>Master-slave communication link wire (310, 330, 360, 400, 440, 500, 560 units applicable)</li> <li>Circuit breakers or fusible disconnects (optional)</li> <li>Electrical wiring to evaporator, BPHE or water pipe heater</li> <li>Wiring sizes per submittal and local codes</li> <li>Terminal lugs</li> <li>Ground connection(s)</li> <li>BAS wiring (optional)</li> <li>Chilled water pump contactor and wiring including interlock</li> <li>Option relays and wiring (optional)</li> <li>Evaporator water bypass valve and wiring (optional)</li> </ul>
Water piping	<ul style="list-style-type: none"> <li>Vents and drain valves on waterbox</li> </ul>	<ul style="list-style-type: none"> <li>Flow switches (Optional)</li> </ul>	<ul style="list-style-type: none"> <li>Taps for thermometers and gauges</li> <li>Thermometers</li> <li>Water pressure gauge</li> <li>Strainers (as required)</li> <li>Vibration Eliminators</li> <li>Isolation and balancing valves in water piping</li> <li>Drain pipe for waterbox and coil drainage</li> <li>Water pipe fix and support</li> </ul>
Relief valve	<ul style="list-style-type: none"> <li>Single or Dual relief valve (Optional)</li> </ul>		<ul style="list-style-type: none"> <li></li> </ul>
Insulation	<ul style="list-style-type: none"> <li>Standard insulation</li> </ul>		<ul style="list-style-type: none"> <li>External water piping insulation</li> </ul>
Partial Heat Recovery Option	<ul style="list-style-type: none"> <li>BPHE with insulation and heater</li> <li>Water pipe heater</li> </ul>		<ul style="list-style-type: none"> <li>Hot water tank</li> <li>Hot water pump</li> <li>Hot water piping</li> <li>Hot water controller and wiring</li> </ul>
Others		<ul style="list-style-type: none"> <li>Cover plate for units (310, 330, 360, 400, 440, 500, 560) units applicable)</li> </ul>	<ul style="list-style-type: none"> <li>Refrigerant (as needed)</li> <li>Dry nitrogen (as needed)</li> </ul>

## Location Requirements

### Noise Considerations

- Locate the unit away from sound-sensitive areas.
- Install the isolation under the unit. Refer to “[Neoprene Isolator Installation](#)”
- Install vibration isolators in all water piping.
- Use soft materials for all electrical hose/wiring to starter/control panel.
- Seal all wall penetrations.

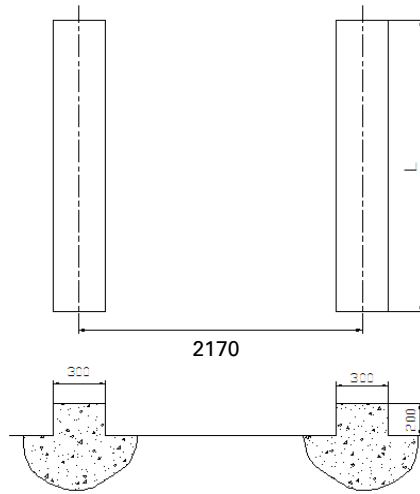
**Note:** Consult an acoustical engineer for critical applications.

### Foundation

Provide a concrete foundation of sufficient strength and mass to support the applicable operating weight (i.e., including completed piping, and full operating charges of refrigerant, oil, and water), as shown in [Figure 2](#) Refer to [Table 2](#) for unit operating weights. Once in place, the unit must be level within 6 mm over its length and width. Trane is not responsible for equipment problems resulting from an improperly designed or constructed foundation.



**Figure 2. Foundation Diagram**



Model	L (mm)
RTXC110XE/XE-HSE	4090
RTXC130/140XE-HSE	4090
RTXC160/180XE/XE-HSE	7480
RTXC200/220XE/XE-HSE	8480
RTXC250/280XE-HSE	8480
RTXC310XE/XE-HSE	13280
RTXC330XE/XE-HSE	13280
RTXC360XE/XE-HSE	16670
RTXC400/440XE/XE-HSE	17670
RTXC500/560XE-HSE	17670

**NOTICE**

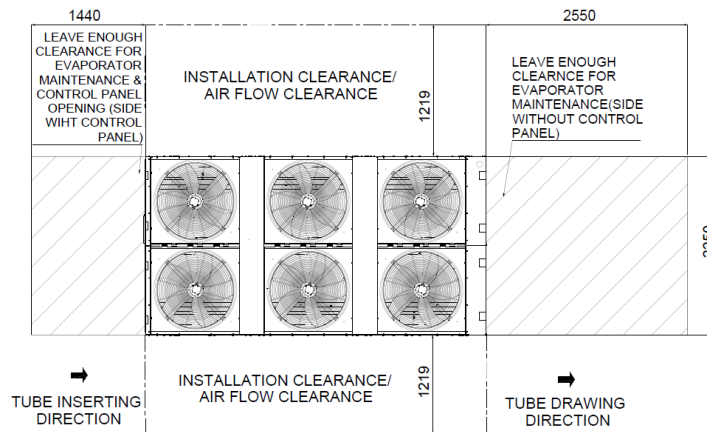
**Foundation is necessary for the convenience of unit service and maintenance.**

## Clearances

Locate the unit so that the condenser airflow is unrestricted both above and on the sides of the unit. Provide enough space around the unit to allow the installation and maintenance personnel and parts unrestricted access to all service points. See Figure 3 for required clearances. Local codes for clearances take precedence over the manufacturer's recommendations when local codes call for greater clearances.

**Figure 3. Acceptable Minimum Clearances**

**Figure 3-1. Installation Clearance – RTXC110XE, 110/130/140XE-HSE**



**Figure 3-2. Installation Clearance – RTXC160XE, 160/180XE-HSE**

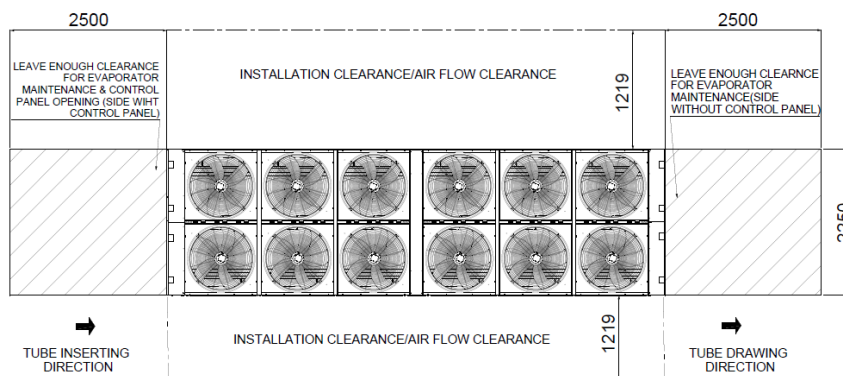


Figure 3-3. Installation Clearance – 200/220XE, 200/220/250/280XE-HSE

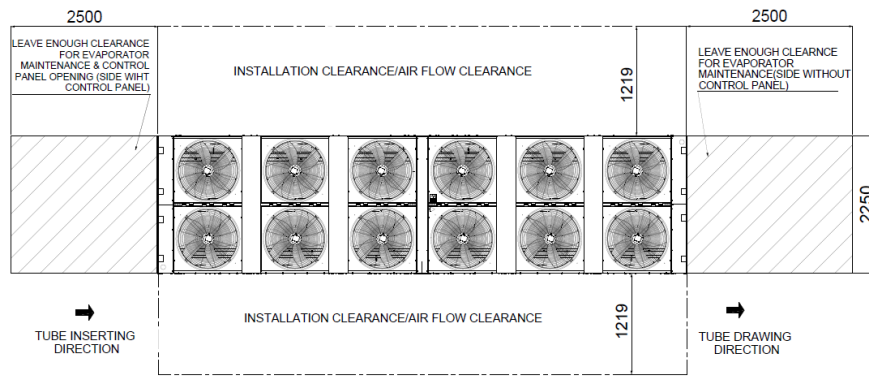
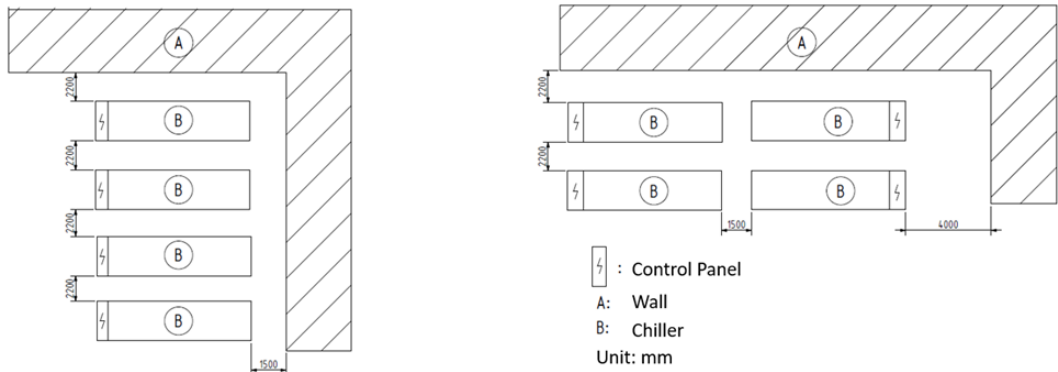


Figure 3-4. Installation Clearance – Multi-Unit



**Note:** In case of the height of enclosure around the unit higher than 1.5m, contact Trane local office.

### NOTICE

**No obstructions to outdoor fan airflow exit, including ductwork.**

If the unit location requires a variance to the clearance dimensions, or any walls or enclosure around the unit, contact your Trane sales office representative.

## Drainage

Locate the unit near a large capacity drain for water drain from evaporator during shutdown or repair, or the condensate water generated by coil during defrost. A drain connection is located at the bottom of the evaporator waterbox. Also, remove the vent plugs at the top of the waterbox to facilitate complete drainage. All local and national codes apply.

### WARNING

#### Hazardous Voltage!

**No stagnant water on the installation site, and the water drainage pipes must be ensured to prevent water from entering the electric control box.**

**Failure to do so may result in equipment damage, electricity leakage, personal injury, or death. On installations where low ambient temperature application is intended and snow accumulations are expected, additional elevation must be provided to ensure electrical safety.**

## Rigging

Refer to lifting instruction label on the unit, a specific lifting method is recommended as follow:

1. The equipment should be moved by lifting. Do not use forklift truck to move or lift the unit.
2. The cables, chains, slings and Lifting beam crossbars must be provided by crane operator and attached on the lifting points. As [Figure 4. RTXC-XE/XE-HSE Rigging, Table 2. Unit lifting weights and center of gravity dimensions.](#)

**NOTICE**

**Fin-tube coil damage!**

Use properly sized lifting beam crossbars to avoid crushing fin-tube coils of the unit with lifting chains.

3. Each of the cables, chains or slings used to lift the unit must be capable of supporting the entire weight of the unit. See [Table 2](#).
4. Keep cables or chains clear of unit sides. As further protection, plywood sheets may be placed against sides of unit, behind cables or chains.
5. After test lift unit at minimal height to verify even level lift, raise and set unit down carefully. Avoid shocks or rolling while handling.
6. Remove the lifting tools after the unit on place.

**NOTICE**

**Alignment and Spacing between Master and Slaver Units!**

Keep units' level and aligned and guarantee 300mm distance on the length direction between Master and slaver unit of 310/330/360/400/440XE, 310/330/360/400/440/500/560XE-HSE.

**Figure 4. RTX-C-XE/XE-HSE Rigging**

Figure 4-1. Rigging – RTX110XE, 110/130/140XE-HSE

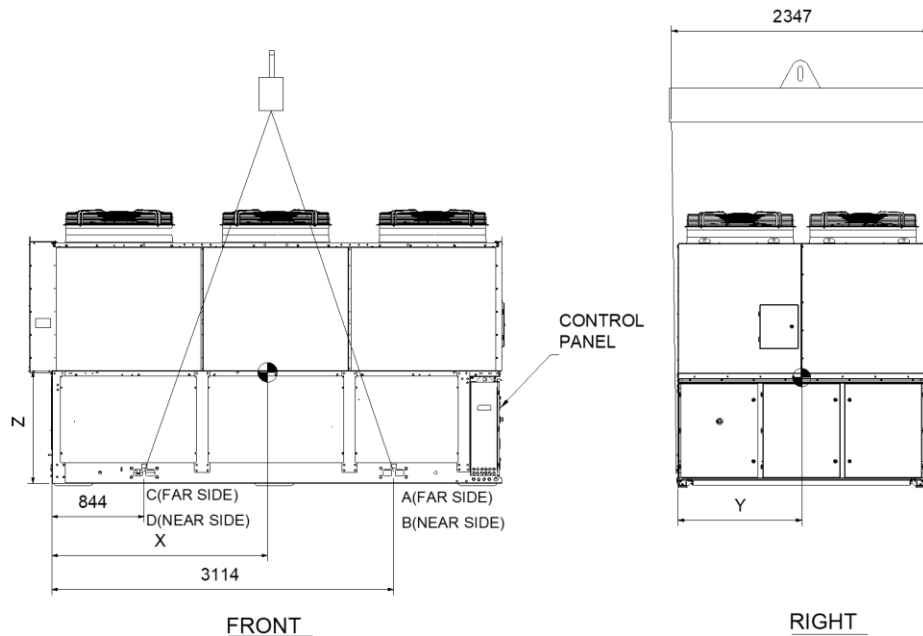


Figure 4-2. Rigging – RTX160/180XE, 160/180XE-HSE

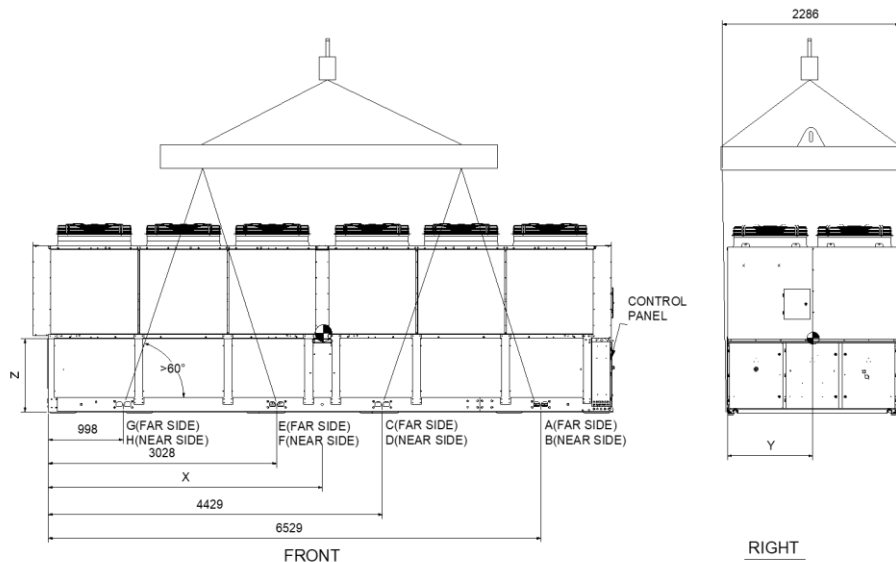


Figure 4-3. Rigging – RTX200/220XE, 200/220/250/280XE-HSE

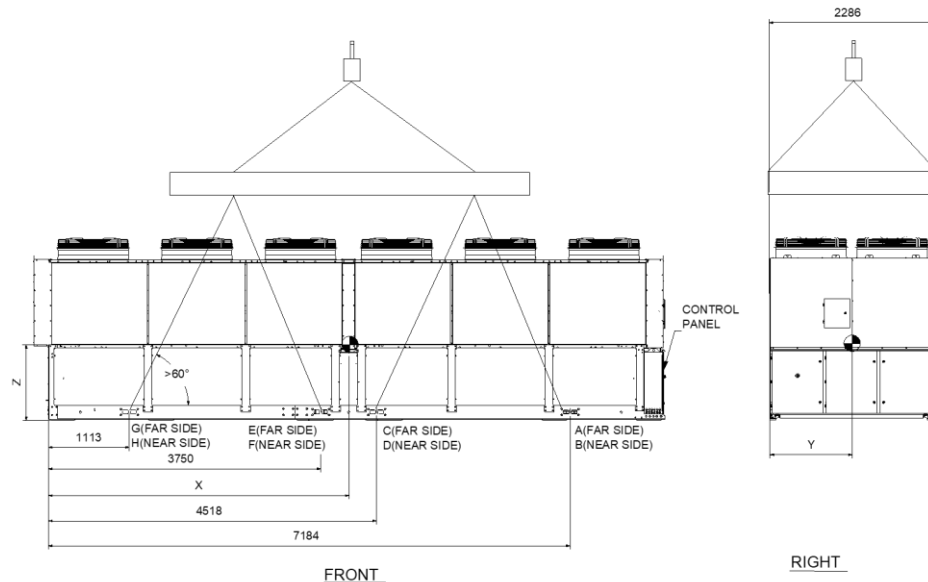


Table 2. Unit lifting weights and center of gravity dimensions

Model	A (kg)	B (kg)	C (kg)	D (kg)	E (kg)	F (kg)	G (kg)	H (kg)	Shipping Weight (kg)	Ckt1 Ref. charge (kg) R134a/R513A	Ckt2 Ref. charge (kg) R134a/R513A	Operating Weight (kg)	Xcg (mm)	Ycg (mm)	Zcg (mm)
RTXC110XE	961	1087	830	1068	-	-	-	-	3945	175/172	-	4220	2075	1120	937
RTXC160XE	762	710	1010	800	784	967	721	800	6550	155/152	155/152	7020	3751	1120	937
RTXC180XE	775	722	1028	814	798	984	734	814	6670	155/152	155/152	7140	3751	1120	937
RTXC200XE	941	841	938	914	898	921	717	819	6991	175/172	175/172	7501	4240	1120	937
RTXC220XE	958	856	955	930	914	938	730	834	7111	175/172	175/172	7621	4240	1120	937
RTXC110XE-HSE	1023	1149	830	1068	-	-	-	-	4069	175/172	-	4344	2125	1120	937
RTXC130XE-HSE	1049	1175	830	1068	-	-	-	-	4121	175/172	-	4396	2125	1120	937
RTXC140XE-HSE	1049	1175	830	1068	-	-	-	-	4121	175/172	-	4396	2125	1120	937
RTXC160XE-HSE	877	825	1010	800	784	967	721	800	6781	155/152	155/152	7251	3851	1120	937
RTXC180XE-HSE	891	838	1028	814	798	984	734	814	6901	155/152	155/152	7371	3851	1120	937
RTXC200XE-HSE	1070	970	938	914	898	921	717	819	7249	175/172	175/172	7759	4340	1120	937
RTXC220XE-HSE	1087	985	955	930	914	938	730	834	7369	175/172	175/172	7879	4340	1120	937
RTXC250XE-HSE	1130	1028	955	930	914	938	730	834	7455	175/172	175/172	7965	4340	1120	937
RTXC280XE-HSE	1130	1028	955	930	914	938	730	834	7455	175/172	175/172	7965	4340	1120	937

## Neoprene Isolator Installation

Isolators are ready to install. Mountings have to be placed on a rigid and level foundation. External equipment should not transmit additional vibration to the unit. The position of neoprene isolator and weight per point are given in the handbook with the unit. Wrong placement along the unit may result in excessive deflection.

1. Refer to [Table 3. Isolator Selection](#), install the optional neoprene isolators at each mounting location as , 200/220/250/280HSE
2. [Figure 5. Isolator Placement](#). Isolators are identified by part number and color.
3. Secure the isolators to the mounting surface, using the mounting slots in the isolator base plate, as shown in [Figure 6. Neoprene Isolator](#). Do not fully tighten the isolator mounting bolts at this time.
4. Align the mounting holes in the base of the unit, with the threaded positioning pins on the top of the isolators.
5. Lower the unit on to the isolators and secure the isolator to the unit with a nut. Maximum isolator deflection should be approximately 6mm.
6. Level the unit carefully. Fully tighten the isolator mounting bolts.

## NOTICE

### Guarantee Alignment and Spacing of Isolators!

RTXC310/330XE/XE-HSE the isolator distance between master 200/220XE/XE-HSE (W7/W8) and slave unit 110XE/XE-HSE (W5/W6) is 3042mm.

RTXC360XE/XE-HSE the isolator distance between master 200XE/XE-HSE (W7/W8) and slave unit 160XE/XE-HSE (W7/W8) is 3462mm.

RTXC400/440XE, 400/440/500/560XE-HSE the isolator distance between master 200/220XE, 200/220/250/280XE-HSE (W7/W8) and slave unit 200/220XE, 200/220/250/280XE-HSE (W7/W8) is 3645mm.

**Figure 5. Isolator Placement**

Figure 5-1. Isolator Placement - RTXC110XE

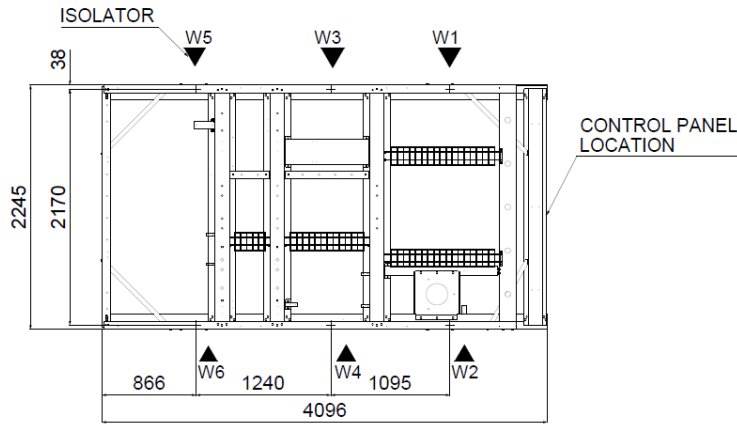


Figure 5-2. Isolator Placement – RTXC110/130/140XE-HSE

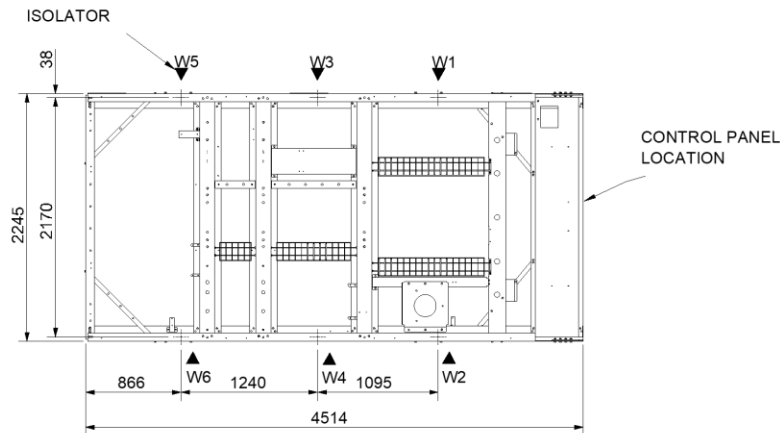


Figure 5-3. Isolator Placement – RTXC160/180XE

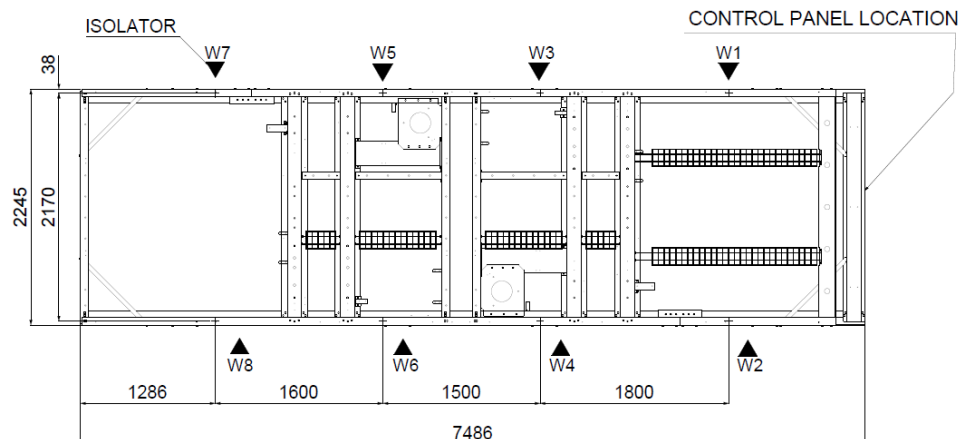


Figure 5-4. Isolator Placement – RTX160/180XE-HSE

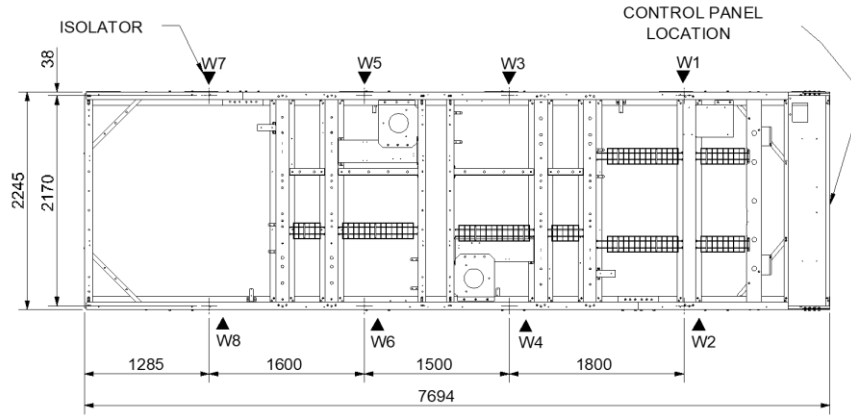


Figure 5-5. Isolator Placement – RTX200/220XE

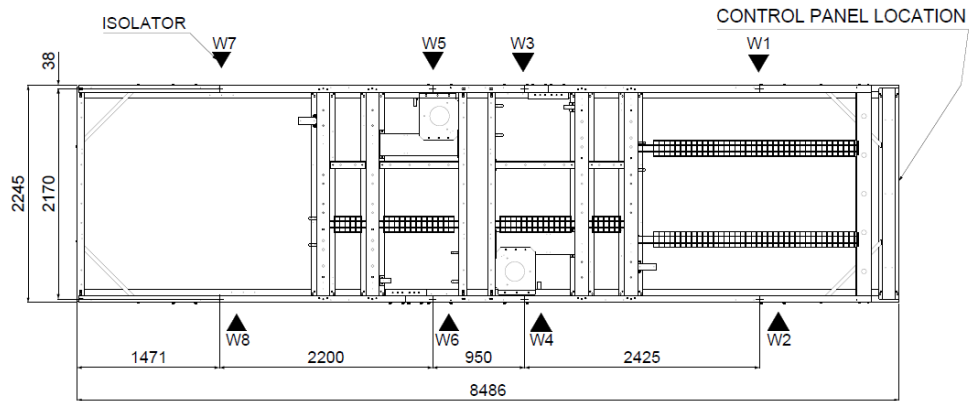


Figure 5-6. Isolator Placement – RTX200/220XE-HSE

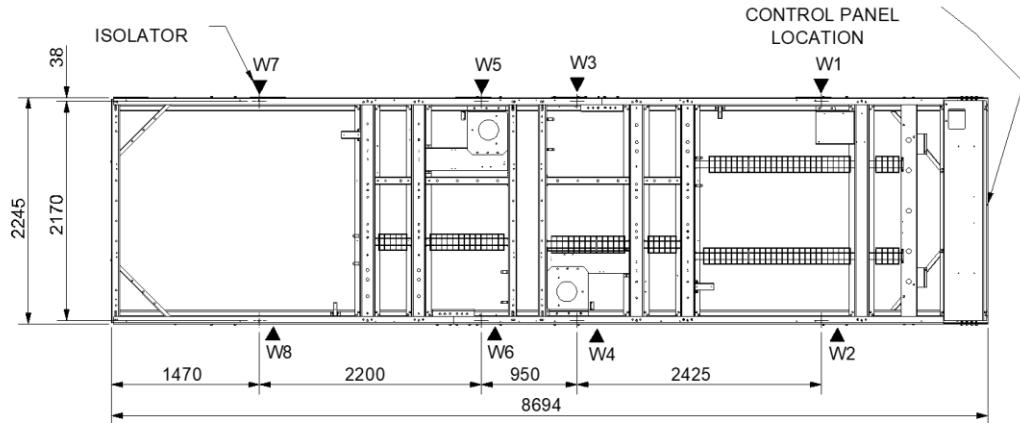
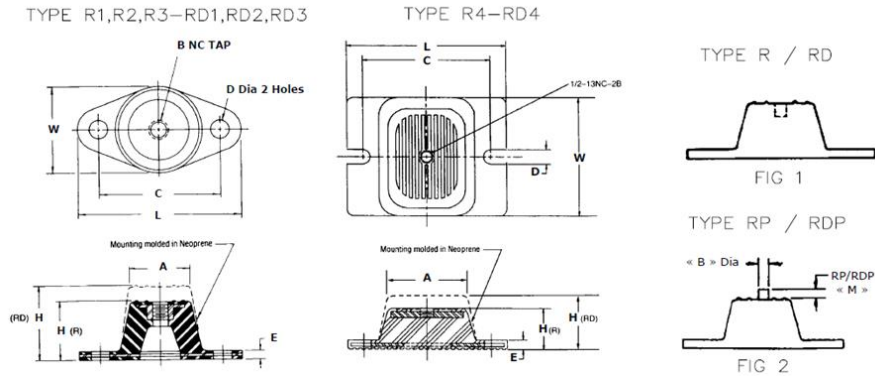


Table 3. Isolator Selection

Unit Model	Neoprene Isolator Part Number	Quantity	Maximum load weight per isolator (kg)
RTXC 110XE, 110/130/140HSE	X10140305630	6	1361
RTXC160XE/XE-HSE	X10140305640	8	1814
RTXC180XE/HSE	X10140305640	8	1814
RTXC200XE/HSE	X10140305630	8	1361
RTXC 220XE, 220/250/280HSE	X10140305630	8	1361
RTXC310XE/HSE	X10140305630	14	1361
RTXC330XE/HSE	X10140305630	14	1361
RTXC360XE/HSE	X10140305640	8	1814
	X10140305630	8	1361
RTXC400XE/HSE	X10140305630	16	1361
RTXC440XE, 440/500/560HSE	X10140305630	16	1361

**Figure 6. Neoprene Isolator**



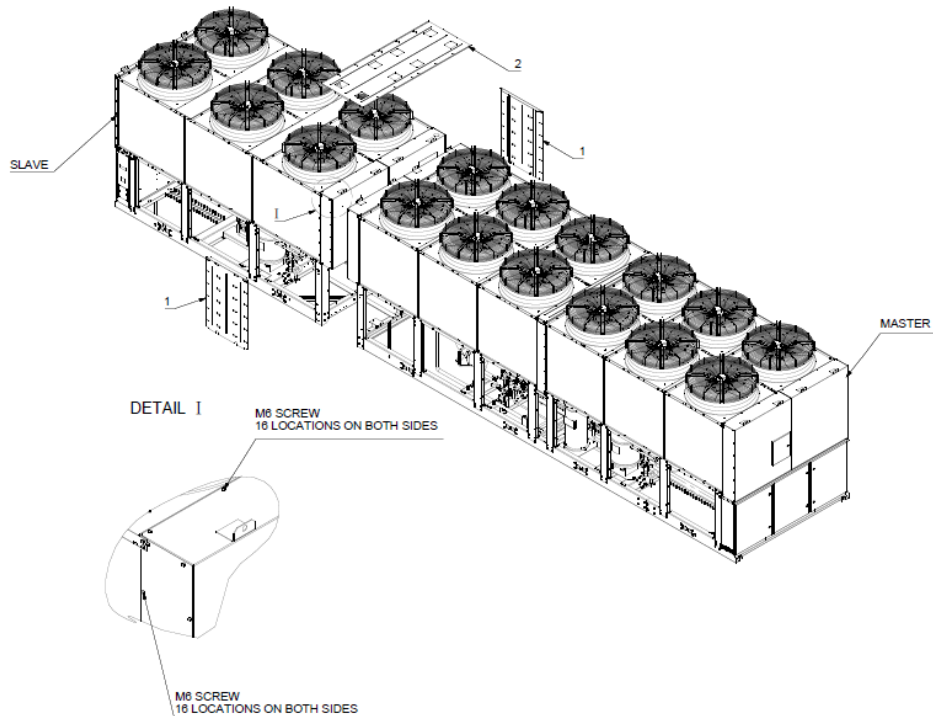
Part Number	Fig	A (mm)	B (mm)	C (mm)	D (mm)	E (mm)	H (mm)	L (mm)	M (mm)	W (mm)	Type	Colour
X10140305630	2	76.2	12.7	127.0	14.2	9.7	69.9	158.8	40.6±6.35	117.6	RDP4-WR	Green-yellow
X10140305640	2	76.2	12.7	127.0	14.2	9.7	69.9	158.8	40.6±6.35	117.6	RDP4-WR	Dark-grey

## Cover Plate of Assembly Unit Installation

1. Keep master and slaver units' level and aligned.
2. Cover plate 1 (10 kg) and plate 2 (21kg) are installed on site.
3. As detailed Detail I of Figure 7, first unscrew the total 32 M6 tapping screws, and install back after the cover plate placed in right position.

*Note: Cover Plate applicable to RTX C310/330/360/400/440XE, 310/330/360/400/440/500/560XE-HSE.*

**Figure 7. Cover Plate Installation**



## Water Piping Piping connection

### ⚠ CAUTION

#### Evaporator Damage!

The water connections to the evaporator are to be flange type. Do not attempt to weld these connections, because the heat generated from welding can cause microscopic and macroscopic fractures on the cast iron water boxes that can lead to premature failure of the water box.

## ⚠ CAUTION

### Water Strainer!

To prevent evaporator damage, pipe strainers must be installed in the water supplies to protect components from water born debris. Trane is not responsible for equipment - only - damage caused by water born debris.

## ⚠ CAUTION

### Equipment Damage!

Thoroughly flush all the water piping before making the final piping connections to the unit after external water piping installation and leakage test. Construct a temporary bypass around the unit for flushing to prevent damage to internal components of the evaporator.

Proper system design and installation procedures should be followed closely. The system must be constructed with pressure tight components and thoroughly tested for installation leaks. Typical chilled water piping system, as [Figure 8](#).

1. Install field-supplied pressure gauges in the water inlet and outlet of the evaporator.  
*Note: for assembly unit, install pressure gauges in the water inlet and outlet of each unit.*
2. Use vibration eliminators to prevent vibration transmission through the water lines.
3. If desired, install thermometers in the lines to monitor entering and leaving water temperatures.
4. A field-supplied water strainer with a minimum size of 20 mesh must be installed close to the evaporator inlet to prevent debris from damaging internal tubes of the evaporator.
5. Install a balancing valve in the leaving water line to control water flow balance. Install shutoff valves on both the entering and leaving water lines so that the evaporator can be isolated for service.
6. Install flow switch in the water outlet of the evaporator with pump interlock to prove system water flow.

## ⚠ CAUTION

### Dual Water Flow Switch!

For assembly unit RTXC 310/330/360/400/440XE, 310/330/360/400/440/500/560XE-HSE, install appropriate water flow switches at the outlet of evaporator for both master and slave units.

7. A vent is provided on the top of the evaporator waterbox. The evaporator can be drained by removing the drain plugs from the bottom of the waterbox. Field- supplied drainage pipe installed should apply to all local and national codes.
8. Be sure to provide additional vents at high points in the piping to bleed air from the water system.
9. Insulate all water piping after leakage test and flushing and provide proper support for the piping.

## ⚠ CAUTION

### Equipment Damage!

To prevent damage to chilled water components, do not allow evaporator pressure to exceed water side maximum working pressure indicated on the evaporator nameplate.

10. The external water piping should be cleaned before the unit is connected to prevent damage to internal components of the evaporator. construct a temporary bypass around the unit during piping clean to prevent damage to internal components of the evaporator.

## ⚠ CAUTION

### Equipment Damage!

After water system clean and leakage test, fully drain the water from evaporator and piping system. Use pressurized air or nitrogen to blow out and ensure that no water stay in the evaporator and piping in winter.

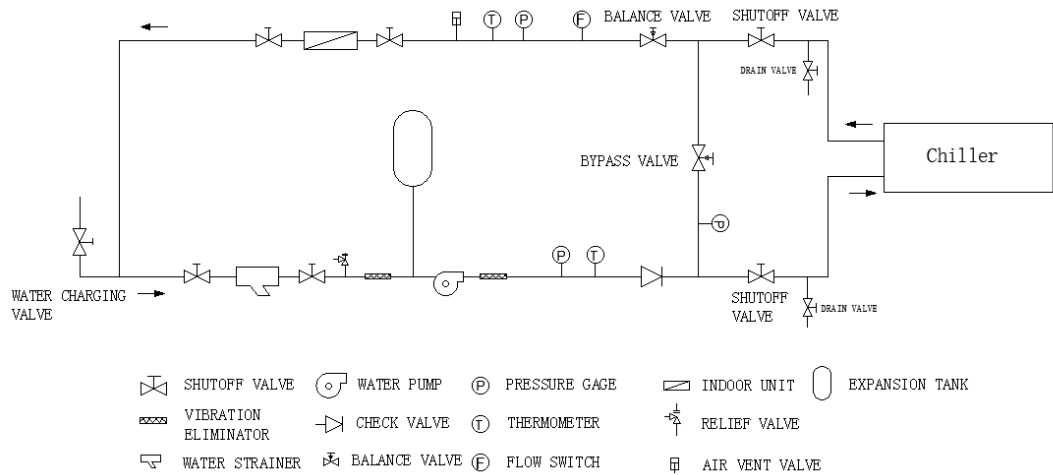


## ⚠ CAUTION

### Equipment Damage!

All inlet and outlet shutoff valves shown in [Figure 8](#) should be always open to enable water circulated by Symbio 800 controlled pump to avoid freezing when the units in operation or standby condition.

**Figure 8. Typical chilled water piping system design**



### Entering Water Piping

- Water strainer
- Vibration eliminators
- Water pressure gauges with shutoff valves
- Thermometers (if desired)
- Shutoff (isolation) valves
- Drain valve

### Leaving Water Piping

- Drain valve
- Shutoff (isolation) valves
- Vibration eliminators
- Balancing valve
- Thermometers (if desired)
- Flow switch
- Water pressure gauges with shutoff valves
- Air vents (to bleed air from system)

### Minimum Water Loop Volume

In order to obtain leaving water temperature stability for comfort cooling applications, a minimum water loop volume of 20 liters per kW for 110, 130, 140 models and 9 liters per kW for 160, 180, 200, 220, 250, 280 is recommended on all unit sizes. If the total water system volume lower than required, including water volume of evaporator, water piping and indoor unit, it may be necessary to add a tank or increase pipe sizes to provide sufficient liquid volume. Any storage tank that is placed in the water loop should have internal baffles to allow thorough mixing of the fluid.

### Flow Switch

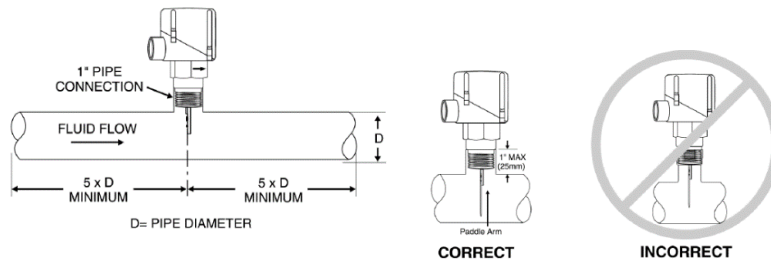
To provide protection, install and wire flow switches in series with the water pump interlocks as required of wiring diagrams. Flow switches must prevent or stop compressor operation if either system water flow drops off below the required minimum shown on [Table 4](#). General guidelines for flow switch installation are outlined below as [Figure 9. Flow Switch Installation](#).

- Mount the flow switch upright, with a minimum of 5 pipe diameters straight, horizontal run on each side. Or install in a vertical pipe if the flow in the upward direction.
- Do not install close to elbows, orifices, or valves.

- Refer to [Table 4. Paddle Size of Water Flow Switch](#), select and trim the paddle to the right length.
- Ensure the paddle arm extends into the main run of the pipe and the arrow on the switch must point in the direction of the water flow after switch tighten to final position.
- To prevent switch fluttering, remove all air from the water system.
- Adjust the switch to open when water flow falls below the required minimum shown on the pressure drop curves as [Figure 10](#). Flow switch contacts are closed on proof of water flow.
- Wire flow switches in series with the water pump interlocks as in Trane wiring diagrams.

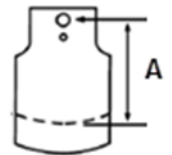
**Note:** Dual flow switch for assembly unit RTXC310/330/360/400/440XE, 310/330/360/400/440/500/560XE-HSE, install appropriate water flow switches at the water outlet of each unit, refer to Section of Master- slave unit.

**Figure 9. Flow Switch Installation**

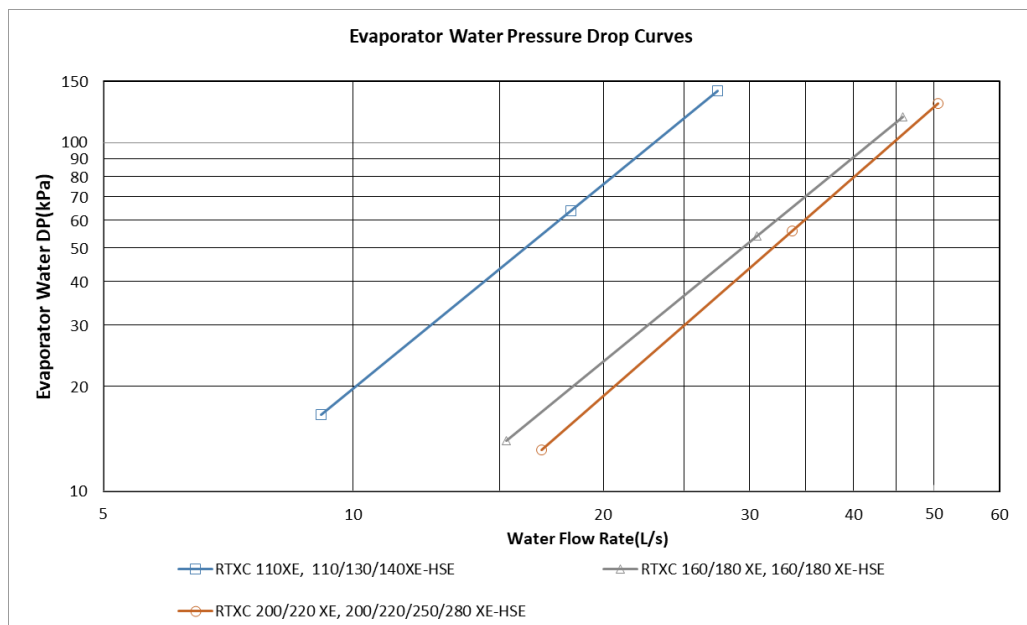


**Table 4. Paddle Size of Water Flow Switch**

Model	Evaporator Water Pipe Size	Recommended Main Water Pipe Size	Trim to Length A (mm)	Rated Water Flow Rate (L/s)	Min Water Flow Rate (L/s)	Max Water Flow Rate (L/s)
RTXC110XE, 110/130/140XE-HSE	DN100	≥ DN100	28	18	9.1	27.3
RTXC160XE, 160XE-HSE	DN150	≥ DN150	70	28	13.9	41.7
RTXC180XE, 180XE-HSE	DN150	≥ DN150	60	31	15.3	45.9
RTXC200XE, 200XE-HSE	DN150	≥ DN150	51	32	16.2	48.5
RTXC220XE, 220/250/280XE-HSE	DN150	≥ DN150	41	36	17.9	53.9



**Figure 10. Evaporator Water Pressure Drop Curves**



**NOTICE**

**Water Flow Protection!**

The Symbio 800 provides a 6-second time delay on the flow switch input before shutting down the unit on a Loss of flow diagnostic. Contact a qualified service organization if nuisance machine shutdowns persist.

## Pump Self-checking

Water pump will be self-checking every time when unit is required to start by leaving water temperature. During the process, the TD7 will display "evaporator water pump self-check." If the water pump self-check fails, the TD7 will alarm water Pump Self-Test Failure.

## Water Pressure Gauges

Install field-supplied pressure gauges (with manifolds, whenever practical) in the water inlet and outlet of the evaporator.

Locate pressure gauges or taps in a straight run of pipe, avoid placement near elbows, etc. Be sure to install the gauges at the same elevation. Provide shutoff valves in lines to the gauges to isolate them from the system when they are not in use.

To read manifolded pressure gauges, open one valve and close the other (depending upon the reading desired). This eliminates errors resulting from differently calibrated gauges installed at unmatched elevations.

## Evaporator Drains

The evaporator can be drained by removing the drain plugs from the bottom of the waterbox. Field-supplied drainage pipe installed should apply to all local and national codes.

## Coil Drains

Field-supplied drainage pipe installed for the condensate water generated by coil during defrost. All local and national codes apply.

## Water Treatment

Using untreated or improperly treated water in these units may result in inefficient operation and possible tube damage. Consult a qualified water treatment specialist to determine whether treatment is needed.

### **⚠ CAUTION**

#### **Proper Water Treatment!**

**The use of untreated or improperly treated water may result in scaling, erosion, corrosion, algae, or slime. It is recommended that the services of a qualified water treatment specialist be engaged to determine what water treatment, if any, is required. Trane assumes no responsibility for equipment failures which result from untreated or improperly treated water, or saline or brackish water.**

## Freeze Protection

For unit operation in a low environment temperature of 0°C or below, multiple measures for freeze protection must be taken against freezing.

1. Heaters are factory installed on water boxes, evaporator shell, partial heat recovery BPHE shell and water pipes as well as insulations to protect the evaporator, PHR BPHE and water pipes from freezing damage in low ambient temperature. Field-supplied 230VAC single-phase power supply for heater should apply to local and national codes.
2. The Symbio 800 control does not check the operation status of electrical heaters. Qualified technicians are required to wire the electric heater power supply, inspect, and confirm the status of electric heaters to avoid catastrophic damage to evaporator or PHR BPHE.
3. Field-supplied heater and insulation are necessary for external water piping, pumps, and other components that may be damaged if exposed to freezing temperatures.
4. Water pumps must be controlled by the Symbio 800 to avoid evaporator tube from freezing by refrigerant migration after unit stop. When no unit operation is possible and the pump is already off, Symbio 800 anti-freeze protection function will command the pump to circulate water to avoid freezing in low ambient temperature condition.
5. Thoroughly drain the water from partial heat recovery water loop in winter.

### **⚠ CAUTION**

#### **Water pump Must be controlled by the Symbio 800!**

**Water pump and heater operation combination can protect the evaporator down to low ambient temperature when the power is available to all of pump, Symbio 800 controller and heater. This**

option will NOT protect the evaporator in the event of power failure to the unit unless backup power is supplied to the necessary components.

### ⚠ CAUTION

#### Equipment Damage!

All inlet and outlet shutoff valves shown in [Figure 8](#) should be always open to enable water circulated by Symbio 800 controlled pump to avoid freezing when the units in operation or standby condition.

### NOTICE

#### Equipment Damage!

The electrical heater of water side should be field-supplied independent 230V single phase AC power source.

### NOTICE

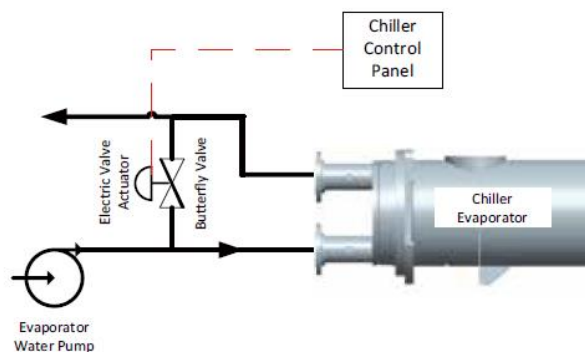
#### Electrical Heater of Water Side Damage!

Failure to connect power after filling water or remove power before draining will result in evaporator immersion heater failure.

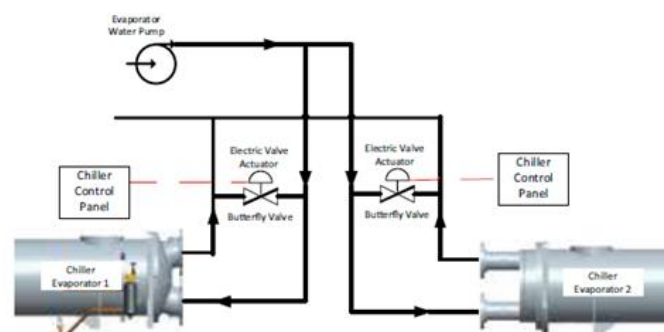
## Evaporator water Bypass Valve Control Options

This option function for field-supplied and installed valve is applicable to low temperature heating condition when the actual leaving water temperature far below the set-point after unit heating for a long time. An electric bypass valve is required to be installed between the inlet and outlet pipes of each evaporator with the maximum bypass water flow rate through the valve at the fully open state no more than 40% of the unit rated water flow. Symbio 800 outputs 0~10VDC signal to adjust the opening of the two-way electric valve to make the leaving water temperature of the unit gradually approach set-point, thereby improving defrosting and heating performance of the unit. The detailed installation is shown in [Figure 11](#) and [Figure 12](#).

**Figure 11. Single Evaporator Water Bypass Valve Setup**



**Figure 12. Dual Evaporator Water Bypass Valve Setup**



# Partial Heat Recovery Piping

## NOTICE

### Proper Water Treatment!

The use of untreated or improperly treated water could result in scaling, erosion, corrosion, algae, or slime. It is recommended that the services of a qualified water treatment specialist be engaged to determine what water treatment, if any, is required. Trane assumes no responsibility for equipment failures which result from untreated or improperly treated water, or saline or brackish water.

## NOTICE

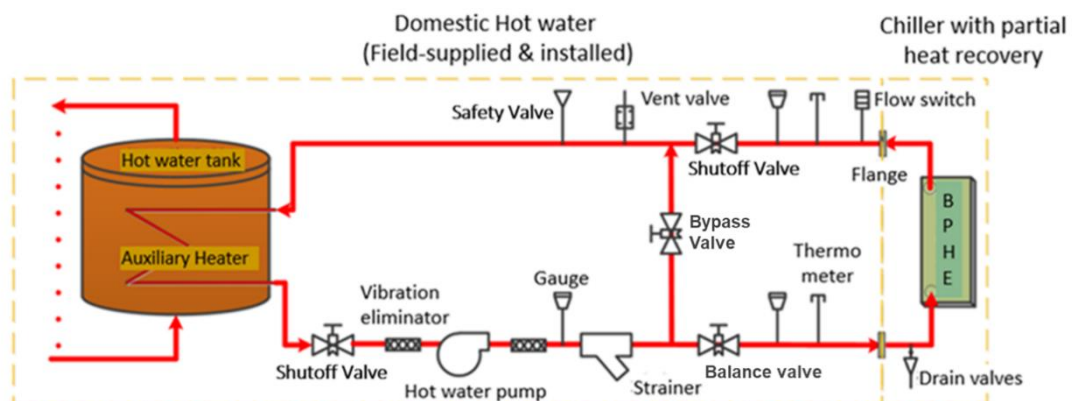
### Equipment Damage!

Do not use untreated or improperly treated water in the heat recovery water loop as it could damage to the unit. It will also cause inefficient operation and potential damage to the unit such as reduced heat transfer between water and refrigerant, increased water pressure drop and reduced water flow.

Water circulating inside the heat recovery heat exchanger should never be used for drinking water, it must be used through an indirect loop to heat or preheat hot water.

**Important:** The installation must comply with the rules and legislation applicable at the jobsite location regarding the use of drinkable water. The use of the water circulating in the heat recovery exchanger as drinkable water is not recommended. An intermediate heat exchanger should be used.

Figure 13. Typical Partial Heat Recovery Piping



For recommended partial heat recovery piping see [Figure 13](#), all the hot water related parts and controller are field supplied and installed by user, including:

- Thermometers
- Water pressure gauges with shutoff valves
- Safety valve
- Hot water pump
- Drain valve (at lowest position)
- Shutoff valves
- Vibration eliminators
- Balancing valve
- Flow switch
- Air vents (to bleed air from system)
- Water strainer
- Insulation

The partial heat recovery water temperature should be controlled via field supplied and installed external device such as a bypass valve or hot water pump, refer to [Table 5](#) for hot water pump selection. In addition, a water tank and additional heater is suggested in the partial heat recovery loop.

A field-supplied water strainer with a minimum size of 16 mesh must be installed close to the BPHE inlet to prevent debris into the heat exchanger. Install shutoff valves on both the entering and leaving water lines so that the BPHE can be isolated for service.

A field installed safety or relief valve on the water side is required for the partial heat recovery to prevent risks resulting from a failure of the thermostat.

Insulate water lines and other portions of the heat recovery water loop to prevent heat loss and potential injury due exposure to a hot surface.

Thoroughly flush all the hot water piping before making the final piping connections to BPHE after external water piping installation and leakage test. Construct a temporary bypass around the unit for flushing to prevent damage to internal components of the BPHE.

**Table 5. PHR BPHE Data**

Unit	PHR BPHE Model	Heat Recovery Capacity (kW)	Water Storage (L)	Rated Hot Water Flow rate (L/s)	Pressure Drop at Rated Flow Rate (kPa)	Connection (mm)
RTXC 110XE, 110/130/140XE-HSE	B60HX28	44.66	3.12	2.14	26.2	DN50
RTXC 160XE, 160XE-HSE	B60HX24	51.64	5.36	2.47	12.9	DN50
RTXC 180XE, 180XE-HSE	B60HX24	72.08	5.36	3.45	23.9	DN50
RTXC 200XE, 200XE-HSE	B60HX24	70.04	5.36	3.35	23.0	DN50
RTXC 220XE, 220/250/280XE-HSE	B60HX24	89.32	6.24	4.27	26.2	DN50

## Partial Heat Recovery Freeze Avoidance

### **NOTICE**

#### **Partial Heat Recovery in Cooling Only!**

The heat recovery water pump should be activated only in cooling mode and stopped in heating mode. Thoroughly drain the water from partial heat recovery water loop in winter.

### **NOTICE**

#### **BPHE Anti-freeze Protection!**

Failure to connect circuit breaker 1Q4 after partial heat recovery BPHE filled with water may result in BPHE freeze failure in winter.

### **NOTICE**

#### **BPHE Heater Damage!**

To prevent partial heat recovery BPHE electrical heater burnout, disconnect the circuit breaker 1Q4 of heater after water drainage.

The partial heat recovery BPHE and the water pipe are equipped with anti-freeze electrical heater, which parallel connected with the evaporator electrical heater and field supplied 230v power by users. ON/OFF of the electrical heater is controlled by the thermostat according to the ambient temperature, which powered on when the ambient temperature lower than 39±6°F, and power off till ambient temperature higher than 49±6°F.

Additional circuit breaker 1Q4 for heat recovery heater is equipped in the control panel which must be disconnected to avoid electrical heater burnout after BPHE water drainage and powered on after BPHE filled with water to prevent from freezing damage in winter.

The partial heat recovery water system should be drained from the lowest point of the hot water piping in winter.



# Electrical Controls

## General Recommendations

In order to ensure the normal operation of the unit electrical components, do not place the unit in dust, corrosive gas or high humidity environment. If these situations exist, corrective measures must be taken.

### ⚠ WARNING

**Hazardous Voltage!**  
**Disconnect all electrical power, including remote disconnects before servicing. Follow proper lockout / tagout (LOTO) procedures to ensure the power cannot be inadvertently energized. Failure to disconnect power before servicing could result in death or serious injury.**

All wiring must comply with local codes. The installation (electrical) contractor must provide and install system interlock wiring and power wiring. Specific electrical wiring diagrams are in Trane wiring diagrams.

### ⚠ CAUTION

**Use Copper Conductors Only!**  
**Unit terminals are not designed to accept other types of conductors. Failure to use copper conductors may result in equipment damage.**

Do not allow conduits, cables, and wires to interfere with other components, structural members, or equipment. All conduits, cables and wires must have sufficient length to fit the location adjustment of compressors and starters. Refer to below table for the recommended wire sizes.

		Unit Size	110	160	180	200	220	310	330	360	400	440
RTXC-XE	Rated Voltage (V/Hz/Ph)		400± 10%/50/3	400± 10%/50/3	400± 10%/50/3	400± 10%/50/3	400± 10%/50/3	400± 10%/50/3	400± 10%/50/3	400± 10%/50/3	400± 10%/50/3	400± 10%/50/3
	Refrigeration Circuit Qty.		1	2	2	2	2	3	3	4	4	4
	Compressor Qty.		1	2	2	2	2	3	3	4	4	4
	Condensing Fan Qty.		6	12	12	12	12	18	18	24	24	24
	Condensing Fan Size (Kw)	EC	1.77	1.77	1.77	1.77	1.77	1.77	1.77	1.77	1.77	1.77
Compressor Motor Data	RLA (Rated Load Amps, A)	AC	1.5	1.5	1.5	1.5	1.5	1.5	1.5	1.5	1.5	1.5
			192	161	161	192	192	192	192	161	192	192
	LRA (Locked Rotor Amps, A)		-	161	161	192	192	192	192	161	192	192
			-	-	-	-	-	-	-	192	192	192
			1161	1089	1089	1161	1161	1161	1161	1089	1161	1161
			-	1089	1089	1161	1161	1161	1161	1089	1161	1161
Condensing Fan Motor Data	FLA (Full Load Amps, A)	EC	2.8	2.8	2.8	2.8	2.8	2.8	2.8	2.8	2.8	2.8
	AC	2.97	2.97	2.97	2.97	2.97	2.97	2.97	2.97	2.97	2.97	2.97
Field Wiring	Single/Dual Point Power		Single	Single	Single	Single	Single	Dual	Dual	Dual	Dual	Dual
	Power Supply Wire Size (Max) mm <sup>2</sup>		1*240	2*300	2*300	2*300	2*300	1*240 / 2*300	1*240 / 2*300	2*300 / 2*300	2*300 / 2*300	2*300 / 2*300
Evaporator Heater Wiring	Recommended Wire Size mm <sup>2</sup>		2.5									

		<b>Unit Size</b>	<b>110</b>	<b>130</b>	<b>140</b>	<b>160</b>	<b>180</b>	<b>200</b>	<b>220</b>	<b>250</b>	<b>280</b>
RTXC-XE-HSE	Rated Voltage (V/Hz/Ph)		400± 10%/50/3	400± 10%/50/3	400± 10%/50/3	400± 10%/50/3	400± 10%/50/3	400± 10%/50/3	400± 10%/50/3	400± 10%/50/3	400± 10%/50/3
	Refrigeration Circuit Qty.		1	1	1	2	2	2	2	2	2
	Compressor Qty.		1	1	1	2	2	2	2	2	2
	Condensing Fan Qty.		6	6	6	12	12	12	12	12	12
	Condensing Fan Size (Kw)	EC	1.77	1.77	1.77	1.77	1.77	1.77	1.77	1.77	1.77
Compressor Motor Data	RLA (Rated Load Amps, A)		192	234	234	161	161	192	192	234	234
	LRA (Locked Rotor Amps, A)		1161	1161	1161	1089	1089	1161	1161	1161	1161
			-	-	-	1089	1089	1161	1161	1161	1161
Condensing Fan Motor Data	FLA (Full Load Amps, A)	EC	2.8	2.8	2.8	2.8	2.8	2.8	2.8	2.8	2.8
Field Wiring	Single/Dual Point Power		Single	Single	Single	Single	Single	Single	Single	Single	Single
	Power Supply Wire Size (Max) mm <sup>2</sup>		1*240	1*240	1*240	2*300	2*300	2*300	2*300	2*300	2*300
Evaporator Heater Wiring	Recommended Wire Size mm <sup>2</sup>		2.5								

		<b>Unit Size</b>	<b>310</b>	<b>330</b>	<b>360</b>	<b>400</b>	<b>440</b>	<b>500</b>	<b>560</b>		
RTXC-XE-HSE	Rated Voltage (V/Hz/Ph)		400± 10%/50/3	400± 10%/50/3	400± 10%/50/3	400± 10%/50/3	400± 10%/50/3	400± 10%/50/3	400± 10%/50/3		
	Refrigeration Circuit Qty.		3	3	4	4	4	4	4		
	Compressor Qty.		3	3	4	4	4	4	4		
	Condensing Fan Qty.		18	18	24	24	24	24	24		
	Condensing Fan Size (Kw)	EC	1.77	1.77	1.77	1.77	1.77	1.77	1.77		
Compressor Motor Data	RLA (Rated Load Amps, A)		192	192	161	192	192	234	234		
			192	192	161	192	192	234	234		
			-	-	192	192	192	234	234		
			1161	1161	1089	1161	1161	1161	1161		
	LRA (Locked Rotor Amps, A)		1161	1161	1089	1161	1161	1161	1161		
			1161	1161	1161	1161	1161	1161	1161		
Condensing Fan Motor Data	FLA (Full Load Amps, A)	EC	2.8	2.8	2.8	2.8	2.8	2.8	2.8		
Field Wiring	Single/Dual Point Power		Dual	Dual	Dual	Dual	Dual	Dual	Dual		
	Power Supply Wire Size (Max) mm <sup>2</sup>		1*240 / 2*300	1*240 / 2*300	2*300 / 2*300	2*300 / 2*300	2*300 / 2*300	2*300 / 2*300	2*300 / 2*300		
Evaporator Heater Wiring	Recommended Wire Size mm <sup>2</sup>		2.5								

### **NOTICE**

#### **Control Fault!**

**To prevent control malfunctions, do not run low voltage wiring (<30V) in conduit with conductors carrying more than 30 volts.**

## Starter Panel

All controls components and motor starts are wired and functional tested in factory. The starter panel enclosure is designed per environmental rating IP54 and be suitable for outdoor use. The starter panel includes the controls for one or two compressors, and a disconnect switch (or a circuit breaker) with handle as the power supply connecting point. The starter panel is divided into the power section for compressors and associated condensing fans, solenoid valve, heater, etc. controls, and the control section of Symbio 800 control system.



For XE unit. power section provides the Wye-Delta starter for each compressor. The Symbio 800 system acquires the compressor motor current of each phase by current transformers, to avoid the damage of running under unbalanced current, under/over current, phase loss or phase reversal. The Symbio 800 system also monitors the line voltage by potential transformer, to avoid the motors are running under abnormal voltage.

HSE power section includes inverter starter for each compressor, Symbio 800 acquired current, power etc. by communicating with inverter.

A control power transformer is offered to provide the 110Vac and 24Vac power supply to the unit control system. The control section includes I/O modules, power supply modules, starter modules and the user interface.

## Power Supply Wiring

All wiring must comply with local codes. Entrance of incoming power for XE wiring is located on the lower right side of the starter panel, for HSE is located on the lower right side of the starter panel or the right-side bottom of starter panel. The wiring is connected to the disconnect switch or circuit breaker.

## Heater Power Supply

The evaporator shell is insulated from ambient air and protected from freezing temperatures by two thermostatically controlled immersion heaters and two strip heaters. Whenever the water temperatures drop to approximately 37°F(2.8°C), the thermostat energized the heaters. The heaters will provide protection from ambient temperatures down to -20°F(-29°C).

It is required to provide an independent power source (230V 50Hz-16amp).

### ⚠ CAUTION

#### Equipment Damage!

**Controller Symbio 800 does not check for loss of power to the heat tape, nor does it verify thermostat operation. A qualified technician must verify power to the heat tape and confirm operation of the heat tape thermostat to avoid catastrophic damage to the evaporator.**

## Unit Water Pump Control

### NOTICE

#### Equipment Damage!

**Trane only allows the customer select either one of the offered schemes for chilled water pump control and evaporator antifreeze protection. Fail to do so may result in equipment damage and the loss of related guaranteed rights without the authorization or approval from Trane.**

## Single Unit Chilled Water Pump Control

For single unit, the Symbio 800 system offers 2 relay contacts of chilled water pump control or integrated dual-pump control, total 3 control schemes are provided.

**Scheme 1**, when the chilled water pump is corresponding with specific unit and controlled by this unit, the relay contact J2-4 and J2-6 of module 1A20 controls the chilled water pump running and stop, when the unit receives the running command, this relay contact will close. In most cases of the unit fault diagnostics appear, this contact will open to shut the chilled water pump, to avoid the pump over thermal.

**Scheme 2**, when the chilled water pump is controlled by customer, the relay contact J2-1 and J2-3 of module 1A20 need to be connected to customer's chilled water pump control circuit, as part of the evaporator antifreeze protection, or when entering the oil return protection, the contact needs to close to activate the pump.

**Scheme 3**, when the unit is configured with integrated dual-pump control, wire the chilled water pumps to unit provided contactors 1K27 and 1K28. Maximum allowable pump motor FLA is 12A for single refrigeration circuit unit, 25A for dual refrigeration circuits unit.

## Master-Slaver Unit Chilled Water Pump Control

For Master-Slave unit, the Master section and Slave section Symbio 800 systems offer 2 relay contacts of chilled water pump control separately, total 3 control schemes are provided.

**Scheme 1**, when the chilled water pump is corresponding with specific unit and controlled by this unit, the relay contact J2-4 and J2-6 of Master section module 1A20 controls the chilled water pump running and stop, when the unit receives the running command, this relay contact will close. In most cases of the unit fault diagnostics appear, this contact will open to shut the chilled water pump, to avoid the pump over thermal. The relay contact J2-1 and J2-3 of Slave section module 1A20 need to be connected to chilled water pump control circuit with Master section water pump control relay 1A20-J2-4 and 1A20-J2-6 in parallel, as part of the evaporator antifreeze protection, or when entering the oil return protection, the contact needs to close to activate the pump.

**Scheme 2**, when the chilled water pump is controlled by customer, the relay contacts J2-1 and J2-3 of Master and Slave section module 1A20 need to be connected to customer's chilled water pump control circuit in parallel, as part of the evaporator antifreeze protection, or when entering the oil return protection, the contact needs to close to activate the pump.

**Scheme 3**, when the unit is configured with integrated dual-pump control, wire the chilled water pumps to unit provided contactors 1K27 and 1K28 for Master and Slave units separately. Maximum allowable pump motor FLA is 12A for single refrigeration circuit section of the unit, 25A for dual refrigeration circuits section of the unit.

## Chilled Water Flow (Pump) Interlock

The Symbio 800 system offers the binary input port for the contact of flow detection device (chilled water flow switch).

For single unit, when the chilled water pump is corresponding with specific unit and controlled by this unit, the customer shall connect the water flow switch and the dry contact of the chilled water pump running feedback in series, then connect to terminal 1X5-39(XE unit)/1X5-33(XE-HSE unit) and 1A6-J3-2. When the chilled water pump is controlled by customer, the water flow switch needs to be connected to terminal 1X5-39(XE unit)/1X5-33(XE-HSE unit) and 1A6-J3-2.

For single unit with integrated dual-pump control, the water flow switch needs to be connect to terminal 1X5-39(XE unit)/1X5-33(XE-HSE unit) and 1A6-J3-2. For Master-Slave unit, when the chilled water pump is corresponding with specific unit and controlled by this unit, the customer shall connect the water flow switch and the dry contact of the chilled water pump running feedback in series, then connect to Master section terminal 1X5-39(XE unit)/1X5-33(XE-HSE unit) and 1A6-J3-2. And connect the water flow switch to slave section terminal 1X5-39(XE unit)/1X5-33(XE-HSE unit) and 1A6-J3-2. When the chilled water pump is controlled by customer, the water flow switch needs to be connected to Master section and Slave section terminal 1X5-39(XE unit)/1X5-33(XE-HSE unit) and 1A6-J3-2 separately.

For Master-Slave unit with integrated dual-pump control, the water flow switches need to be connected to terminal 1X5-39(XE unit)/1X5-33(XE-HSE unit) and 1A6-J3-2 separately.

### **NOTICE**

#### **Important!**

**Do not start/stop the unit by activating/deactivate the chilled water pump, this will lead the compressor(s) to full load then shut. Utilize the External Auto/Stop input for unit start/stop operation.**

## Partial Heat Recovery Heater Power Supply

The partial heat recovery heat exchanger and water piping are insulated from ambient air and protected from freezing temperatures by thermostatically controlled electrical heaters. They are shared with the evaporator electric heating power supply.

**Note:** *The heaters should only be powered on when the heat recovery heat exchanger has water in it. If partial heat recovery heat exchanger is drained, the heaters must be turned off by shutting circuit breaker 1Q4 to avoid heaters burnout.*

## Alarm and Status Relay Outputs (Programmable Relays) – Optional

The Symbio 800 system provides a programmable relay concept for enunciation of certain events or states of the unit. Total four relays are provided (generally with a Quad Relay Output LLED) as part of the Alarm Relay Output Option.

The list of events/states that can be assigned to the programmable relay LLED 121 can be found in below table.

Events/States	Description
Alarm - Latching	This output is true whenever there is any active diagnostic that requires a manual reset to clear, that affects the unit, or the Circuit. This classification does not include informational diagnostics.
Alarm – Auto Reset	This output is true whenever there is any active diagnostic that could automatically clear, that affects the unit, or the Circuit. This classification does not include informational diagnostics.
Alarm	This output is true whenever there is any diagnostic affecting any component, whether latching or automatically clearing. This classification does not include informational diagnostics.
Unit Limit Mode	This output is true whenever the unit has been running in any unloading types of limit modes continuously a certain time period (default is 10 minutes).
Maximum Capacity	This output is true whenever the unit has reached maximum capacity for a certain time period (default is 10 minutes); whenever the unit has quitted the maximum capacity for a certain time period, this output is false.
Compressor Running	This output is true whenever compressor is running on the unit.
Heating/Cooling Mode	This output is true whenever unit is running under heating mode (include warm up, defrost); This output is false whenever chill is running under cooling mode.

Symbio 800 Service Tool (TracerTU) is used to install the Alarm and Status Relay Option package and assign any of the above list of events or status to each of the four relays provided with the option.

The default assignments for the four available relays of the RTXC-XE/RTXC-XE-HSE Alarm and Status Package Option are:

LLID Naming	Assignment	Contact Terminal	Default Setting
Unit Status Programmable Relay	Relay 1	1A21, J2-10,11,12	Maximum Capacity
	Relay 2	1A21, J2-7,8,9	Compressor Running
	Relay 3	1A21, J2-4,5,6	Alarm
	Relay 4	1A21, J2-1,2,3	Unit limit

The relay will be energized when the event/state occurs.

## Emergency Stop

Symbio 800 provides auxiliary control for a customer specified/installed latching trip out. When this customer-furnished remote contact is provided, the unit will run normally when the contact is closed. When the contact opens, the unit will trip on a manually resettable diagnostic. This condition requires manual reset at the TD7 display. When this function is required, remove the jumper W2, which is on terminal 1X5-40 and 1X5-41(XE unit)/ 1X5-50 and 1X5-51(XE-HSE unit), then connect to the emergency stop device contact. Dry contact is acceptable only.

For Master-Slave unit, remove the jumpers W2, which are on Master section and Slave section terminal 1X5-40 and 1X5-41(XE unit)/ 1X5-50 and 1X5-51(XE-HSE unit), then connect to the emergency stop device contacts, the contacts shall derive single emergency stop switch.

## External Auto/Stop

If the unit requires the external Auto/Stop function, the installer must remove the jumper W1 which is on J2-1 and J2-2 of module 1A14, then connect to the remote contact. Dry contact is acceptable only. The unit will run normally when the contacts are closed. When either contact opens, the compressor(s), if operating, will go to the RUN: UNLOAD operating mode and cycle off. Unit operation will be inhibited. Closure of the contacts will permit the unit to return to normal operation. For Master-Slave unit, no action is needed for the Slave section.

## Heating/Cooling Mode Setting

The unit heating/cooling mode can be set by the “Setting” button of the display screen. Symbio 800 also provides auxiliary control for a running mode. Connect a remote device contact to the J2-3 and J2-4 of module 1A19 can realize this function. Closure of the contact activates the “Heating” mode, otherwise activates the “Cooling” mode. Dry contact is acceptable only. For Master-Slave unit, no action is needed for the Slave section.

## External Current Limit Setpoint – Optional

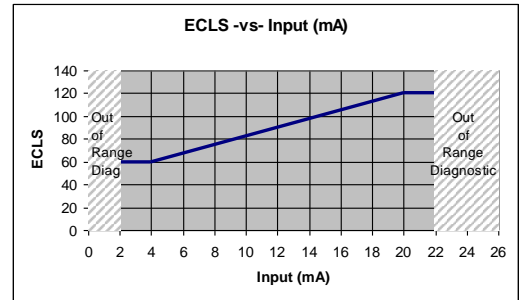
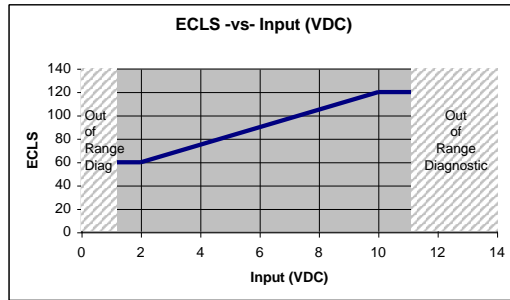
The Symbio 800 provides inputs (J2-2 and J2-3 of module 1A22) that accept either 4-20 mA or 2-10 VDC signals to set the External Current Limit Setpoint. The 4-20 mA or 2-10 VDC signals are corresponding with unit 60%~120%RLA range.

For the 2-10 VDC signal:

$$\text{External current limit setpoint} = 7.5 * \text{Input signal} + 45.0\%$$

For the 4-20 mA signal:

$$\text{External current limit setpoint} = 3.75 * \text{Input signal} + 45.0\%$$



TracerTU ServiceTool is used to set the input signal type from the factory default of 2-10 VDC to that of 4-20 mA. TracerTU is used to install or remove the External Current Limit Setpoint option and adjust the maximum or minimum value setting.

## External Chilled/Hot Water Setpoint

The Symbio 800 provides inputs (J2-5 and J2-6 of module 1A22) that accept either 4-20 mA or 2-10 VDC signals to set the External Chilled/Hot Water Setpoint.

When unit is running under cooling mode, external water setpoint will be set as the chilled water temperature setting. External water temperature setpoint shall have the configuration with maximum and minimum value.

When unit is running under heating mode, external water setpoint will be set as the hot water temperature setting. External water temperature setpoint shall have the configuration with maximum and minimum value.

For the 2-10 VDC signal:

$$\text{External water temperature setpoint} = \text{Minimum Value} + (\text{Maximum Value} - \text{Minimum Value}) * (\text{Input signal} - 2) / 8$$

For the 4-20 mA signal:

$$\text{External water temperature setpoint} = \text{Minimum Value} + (\text{Maximum Value} - \text{Minimum Value}) * (\text{Input signal} - 4) / 16$$

TracerTU ServiceTool is used to set the input signal type from the factory default of 2-10 VDC to that of 4-20 mA. TracerTU is used to install or remove the External Chilled/Hot Water Setpoint option and adjust the maximum or minimum value setting.

## Building Automation Control System Communication Interface

### LonTalk Communications Interface (LCI-C)

Symbio 800 provides an optional LonTalk Communication Interface (LCI-C) between the unit and a Building Automation System (BAS). An LCI-C module shall be used to provide "gateway" functionality between a LonTalk compatible device and the unit.

### Modbus Communications Interface (MODB)

Symbio 800 provides an optional Modbus Communication Interface (MODB) between the unit and a Building Automation System (BAS). This communication is conducted by the RS-485 connection with RTU protocol.

## BACnet Communications Interface (BCI-C)

Symbio 800 provides an optional BACnet Communications Interface (BCI-C) between the unit and a Building Automation System (BAS).

See Trane wiring diagrams for details.

## Master-Slave Unit Wiring Connection

(RTXC 310/330/360/400/440XE, 310/330/360/400/440/500/560XE-HSE units)

RTXC-XE/XE-HSE units have installed the modules of unit status. The Master-Slave unit operation is conducted by the wired connection among Unit Running/Stop Output module 1A26, External Auto/Stop module 1A14 and Heating/Cooling Mode Setting module 1A19.

- Connect the 1A26-J2-6 of Master unit to 1A19-J2-3 of Slave unit.
- Connect the 1A26-J2-4 of Master unit to 1A19-J2-4 of Slave unit.
- Connect the 1A26-J2-3 of Master unit to 1A14-J2-1 of Slave unit.
- Connect the 1A26-J2-1 of Master unit to 1A14-J2-2 of Slave unit.

Remove the jumpers W3 which are on terminal 1X5-44 and 1X5-45(XE unit)/ 1X5-46 and 1X5-47(XE-HSE unit) for both Master and Slave units.

- Connect the terminal 1X5-42 of Master unit to terminal 1X5-44 of Slave unit(XE unit).
- Connect the terminal 1X5-43 of Master unit to terminal 1X5-45 of Slave unit(XE unit).
- Connect the terminal 1X5-48 of Master unit to terminal 1X5-46 of Slave unit(XE-HSE unit).
- Connect the terminal 1X5-49 of Master unit to terminal 1X5-47 of Slave unit(XE-HSE unit).

See Trane wiring diagrams for details.

Master-Slave unit setpoints notes:

1. Configure the same chilled/hot water setpoint for both Master and Slave units.
2. Set the Slave unit as Auto and Cooling mode.

***Important: When set the Master unit as Auto mode, the Slave unit still can operate independently.***

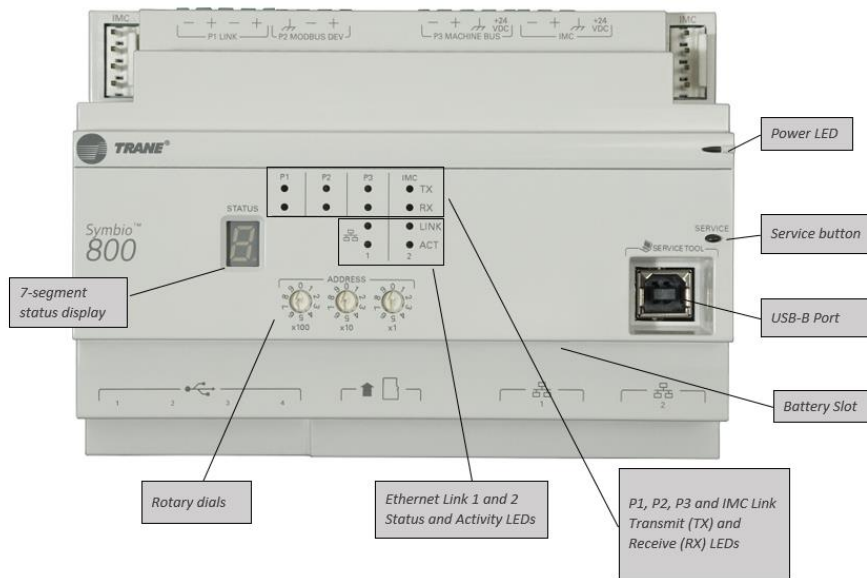
# Operator Interface Controls

## Symbio800 Overview

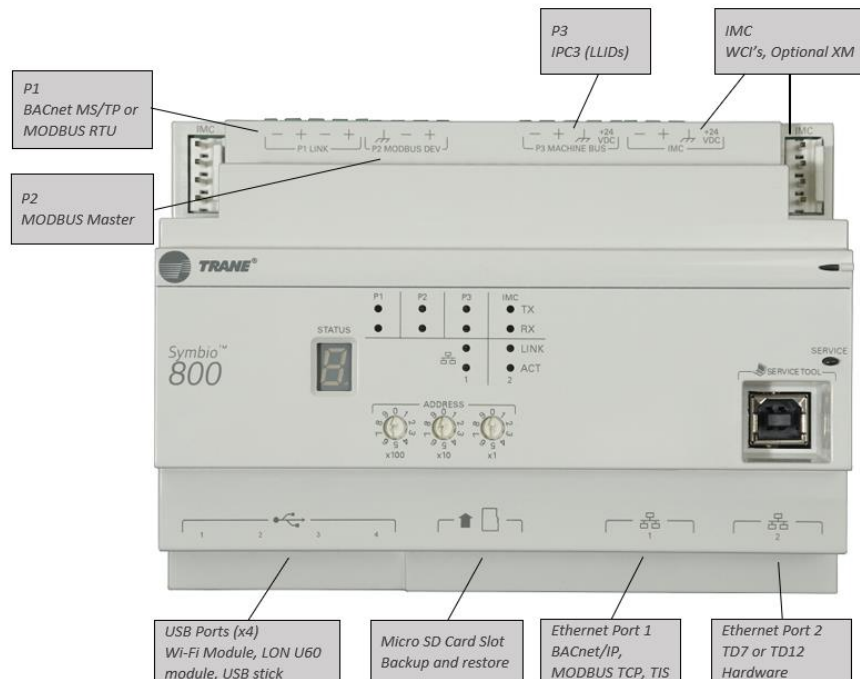
This section covers information pertaining to the Symbio™ 800 controller hardware. The Symbio™ 800 controller is a factory-installed, application specific and programmable controller designed to control chillers and large packaged HVAC equipment. A 7-inch user interface features a touch sensitive color screen that provides facility managers at-a-glance operating status, performance monitoring, scheduling changes, and operating adjustments. Other advanced features include automated controller backup, and optional features such as secure remote connectivity, wireless building communications, mobile device connectivity, and custom programming with expandable I/O.

For more information, see Symbio 800 Installation, Operation, and Maintenance manual BAS-SVX080\*- EN.

**Figure 14. Front View of Symbio 800**



**Figure 15. Wiring Locations and Connection Ports**



# TracerTU

The AdaptiView™ TD7 operator interface allows for daily operational tasks and setpoint changes. However, to adequately service chillers, Tracer® TU service tool is required. (Non-Trane personnel, contact your local Trane office for software purchase information.) TracerTU adds a level of sophistication that improves service technician effectiveness and minimizes chiller downtime. This portable PC-based service-tool software supports service and maintenance tasks, and is required for software upgrades, configuration changes and major service tasks.

TracerTU serves as a common interface to all Trane chillers and will customize itself based on the properties of the chiller with which it is communicating. Thus, the service technician learns only one service interface.

The panel bus is easy to troubleshoot using LED sensor verification. Only the defective device is replaced.

TracerTU can communicate with individual devices or groups of devices.

All chiller status, machine configuration settings, customizable limits, and up to 100 active or historic diagnostics are displayed through the service-tool software interface.

LED and their respective TracerTU indicators visually confirm the availability of each connected sensor, relay, and actuator.

TracerTU is designed to run on a customer's laptop, connected to the Tracer AdaptiView control panel with a USB cable. Your laptop must meet the following hardware and software requirements:

- 1 GB RAM (minimum)
- 1024 x 768 screen resolution
- CD-ROM drive
- Ethernet 10/100 LAN card
- An available USB 2.0 port
- Windows 7 Enterprise or Professional operating system (32-bit or 64-bit)

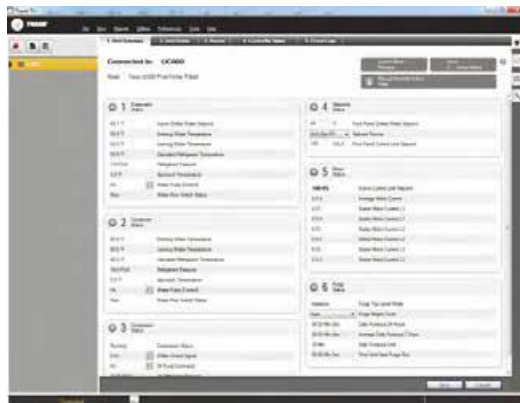
**Note:** Tracer TU versions 8.6 and earlier will also support Microsoft® Windows® XP Professional operation system with Service Pack 3 (SP3) .

- Microsoft .NET Framework 4.0 or later

**Note:**

1. Tracer® TU is designed and validated for this minimum laptop configuration. Any variation from this configuration may have different results. Therefore, support for Tracer TU is limited to only those laptops with the configuration previously specified.
2. For more information, see TTU-SVN01\*-EN Tracer® TU Getting Started Guide.

**Figure 16. TracerTU**

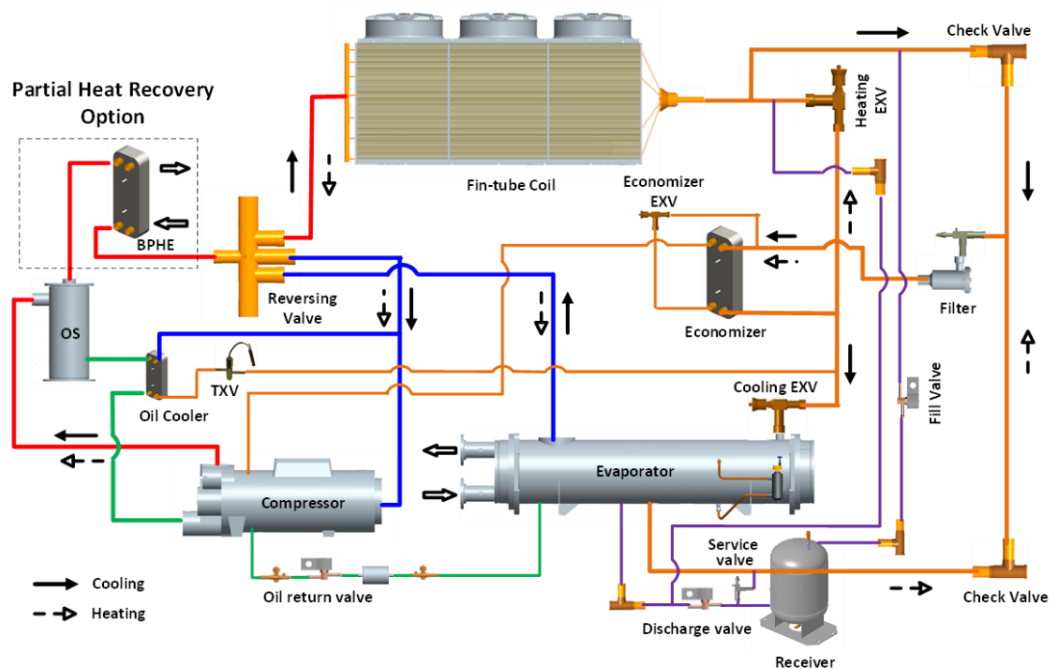


# Operating Principles

## General

The refrigeration cycle of RTX-C-XE/XE-HSE is conceptually similar to that of other Trane air-cooled screw heat pumps, including single refrigerant circuit unit, dual refrigerant circuit unit, and assembly unit with master-slave control system. RTX110XE/XE-HSE apply single refrigerant circuit with one compressor with economizer and one water loop. RTX180/220XE/XE-HSE units use dual refrigerant circuits with two compressors with economizer and one water loop, while RTX160/200XE/XE-HSE are without economizer. RTX310/330/360/400/440XE, 310/330/360/400/440/500/560XE-HSE units are duplex units assembled by customer on site. [Figure 17](#) shows the schematic of a single refrigerant circuit with economizer and partial heat recovery option.

**Figure 17. RTX-C-XE/XE-HSE Single Refrigerant Circuit (Economizer Only for RTX110/180/220XE/XE-HSE)**



## Refrigerant

### **NOTICE**

#### **Equipment Damage!**

Use only refrigerants specified on the unit nameplate and Trane OIL00388.

Failure to do so may cause compressor damage and improper unit operation.

## Compressor

The compressor is of cast iron, semi-hermetic construction, twin screw type. Each compressor has two rotors - "male" and "female" - which provide compression. The male rotor is attached to, and driven by, the motor, and the female rotor is, in turn, driven by the male rotor. Separately housed bearing sets are provided at each end of both rotors. A two-pole, hermetic, induction motor (3000 rpm at 50 Hz, 3600 rpm at 60 Hz) drives the compressor rotors. The motor is cooled by suction refrigerant gas, entering the end of the motor housing through the suction line.

The female side port provides a capacity step from 30% to approximately 60% displacement. The slide piston uncovers a series of radial ports in the top of the male rotor bore area of the housing, providing continuously variable unloading from 60% to approximately 100% of compressor suction flange volume flow rate.



Economizers can be used with the compressor to increase cycle capacity and in some cases improve cycle efficiency, depending on the port machined into the rotor housing for economizer gas injection. The economizer should only be modulated once the compressor is running at 100% load and closed before the compressor shut down.

## Oil Filter

Each compressor is equipped with a replaceable element oil filter. The filter removes any impurities that could foul the solenoid valve orifices and compressor internal oil supply galleries.

## Air Side Heat Exchanger

Air-cooled heat exchangers are wavy aluminum fins mechanically bonded to internal-finned copper tubing and factory proof and leak tested. Direct-drive axial discharge fans are balanced and individually protected. Three-phase fan motors with permanently lubricated ball bearings and external thermal protection are provided. Units will start and operate at ambient range from 32°F (0°C) to 114.8°F (46°C) in cooling mode, and from 14°F (-10°C) to 70°F (21°C) in heating mode, Unit 110,160,180,200,220 ton with R513A can reach 10.4°F (-12°C).

## Water Side Heat Exchanger

RTXC-XE/XE-HSE uses a falling film evaporator to exchange heat of refrigerant in the shell side with water flow in tubes. In cooling mode, liquid refrigerant evenly drops on the external surface of tube bundle and exchange heat with water flow in tube, specified liquid level in falling film maintained by expansion valve to ensure high efficiency of the heat exchange, vaporized refrigerant exit through the suction line, excessive refrigerant and oil left at the bottom of falling film through oil return valve back to compressor. In heating mode, the refrigerant gas discharged by the compressor through the tube bundle to release heat, and the condensed liquid refrigerant drain from the bottom of the shell.

Electrical heaters embedded in both sides of water box and an electrical heat strip twined on the outside surface of the shell beneath the insulation to prevent heat exchanger from freeze in the winter. Additional 230V field provided single phase power connection is required to power the heaters

### **⚠ CAUTION**

#### **Equipment Damage!**

**The electrical heater of water side should be field-supplied an independent 230V single phase AC power source.**

## Economizer (Only for RTXC110/180/220XE, 110/180/220/250/280XE-HSE)

RTXC-XE/XE-HSE adopts brazed plate heat exchanger as economizer. A portion of liquid refrigerant through economizer EXV to vaporize and create the additional sub-cooling to the major liquid refrigerant is injected into the compressor at a midway point of the compression process. The major of liquid flow cooled down goes through the main EXV to the evaporator. Therefore, enhances cycle capacity and in some cases improve cycle efficiency by increasing compressor displacement and degree of sub-cooling of the main refrigerant circuit.

## Expansion Valve

RTXC-XE/XE-HSE main refrigerant loop uses two electrical expansion valves for cooling and heating respectively. In cooling condition, cooling EXV modulate according to the liquid level of the falling film monitoring by liquid level sensor. In heating condition, heating EXV control according to the suction superheat of compressor. The flow of refrigerant into the economizer branch is also controlled by the electronic expansion valve per the superheat of gas injected into compressor. Oil circuit using TXV to maintain the oil temperature by adjust refrigerant flow rate through oil cooler.

## Oil Separator

The compressor discharge refrigerant gas to the tangential entrance at the top of oil separator and rotate along the cylinder, oil droplets throw out from the refrigerant gas by the centrifugal force and fall downward the cylinder into the oil sump at the bottom, then return to compressor. The purified refrigerant gas exit from the top of the oil separator and flow into the condenser through reversing valve.

## Fan

In cooling condition, all fans operate in high speed when ambient temperature is high, automatically adjust fan stage for AC fans or fan speed for EC fans when ambient temperature decreased. In heating condition, all fans run in high speed except warmup and defrost. The fans are propeller-type and not recommended for use with ductwork, filters, or other impediments to airflow in the fan air stream.

## Oil Circuit

The majority of the oil that is mixed with vaped refrigerant discharged from compressor is separated and recollected at the bottom of the oil separator, minority rest oil enters system with refrigerant discharge gas. The majority oil in the sump flows through oil cooler, shut off valve, internal filter, and oil supply check valve back to compressor then divides into two ways: one oil flow injects into rotors from top shell of compressor to lubricate rotors and seal the gaps between rotors and house, another oil flow injects into the bearing chamber to lubricate bearing then return to suction port of rotors through internal oil channel of compressor shell. All the two-oil flow mixed with refrigerant gas through rotors discharge back to oil separator. In cooling mode, the minority oil accumulated in refrigerant liquid of evaporator go back to the bottom cavity of compressor through oil return solenoid valve of oil return pipe; or in heating mode, the oil in the coil returns to the compressor with refrigerant suction gas while the oil return solenoid valve closed.

Oil supply check valve is a pressure activated valve. When the compressor operates, the discharge pressure generated opens the check valve to allow the oil flow. When the compressor stops, the check valve is closed to isolate the oil in oil separator from compressor.

## Receiver

The receiver used to temporally store larger volume of refrigerant liquid in coil before mode switch from defrost back to heating in order to avoid refrigerant liquid slugging to compressor that may cause the compressor damage. Refer to [Table 6](#), the receiver solenoid valve status.

**Table 6. Receiver Solenoid Valve Status**

<b>Compressor Running</b>	<b>Cooling Mode (including warmup, defrost)</b>	<b>Heating Mode</b>
Fill valve (Normal Close)	Close (de-energized)	Close (de-energized)
Discharge valve (Normal Open)	Open (de-energized)	Close (energized)
<b>Compressor Stopped</b>	<b>Cooling Shutdown</b>	<b>Heating Shutdown</b>
Fill valve (Normal Close)	Close (de-energized)	Close (de-energized)
Discharge valve (Normal Open)	Open (de-energized)	Close (energized)

## Partial Heat Recovery Option

The partial heat recovery is comprised of an auxiliary BPHE heat exchanger installed in the discharge line between the oil separator and the reversing valve. The heat exchanger cools compressor discharge gas and rejects the energy to a separate water loop for hot water applications. The unit can simultaneously produce chilled and hot water. The heating capacity is driven by the cooling demand on the unit, the condensing temperature, and the flow rate through the heat exchanger.

The partial heat recovery includes:

- Brazed plate heat exchanger (BPHE)
- Piping between the heat exchanger(s)
- Insulation of the heat exchanger(s) and water pipe
- Heater on partial heat recovery heat exchanger(s) and water pipe

**Note:** *Symbio 800 does not monitor, implement, and display any partial heat recovery mode and status. The partial heat recovery controller should be designed and installed by user on field.*

# RTXC-XE/XE-HSE Operating Map

## Cooling Mode:

<b>Water Side Heat Exchanger (Evaporator)</b>	<b>Min Temperature (°C)</b>	<b>Max Temperature (°C)</b>
Entering Water Temperature (Startup)	-	45
Leaving Water Temperature (Running)	5	18
<b>Air Side Heat Exchanger (Condenser)</b>	<b>Min Temperature (°C)</b>	<b>Max Temperature (°C)</b>
Entering Air Temperature	0	46

## Heating Mode:

<b>Water Side Heat Exchanger (Condenser)</b>	<b>Min Temperature (°C)</b>	<b>Max Temperature (°C)</b>
Entering Water Temperature (Startup)	10	50
Leaving Water Temperature (Running)	20	55
<b>Air Side Heat Exchanger (Evaporator)</b>	<b>Min Temperature (°C)</b>	<b>Max Temperature (°C)</b>
Entering Air Temperature		
All Units with R134a, and Unit 130,140,250,280 ton with R513A	-10	30
Unit 110,160,180,200,220 ton with R513A	-12	30

## Partial Heat Recovery Mode:

<b>Water Side Heat Exchanger (Evaporator)</b>	<b>Min Temperature (°C)</b>	<b>Max Temperature (°C)</b>
Entering Water Temperature (Startup)	-	45
Leaving Water Temperature (Running)	5	18
<b>PHR Heat Exchanger (Hot Water)</b>	<b>Min Temperature (°C)</b>	<b>Max Temperature (°C)</b>
Entering Hot Water Temperature (Startup)	10	50
Entering Hot Water Temperature (Running)	25	60

*Note: altitude up to 1000 m above mean sea level.*

## **NOTICE**

### **Anti-Freeze Protection!**

Failure to follow the anti-freeze protection of the manual when unit operates in an ambient temperature of 0°C or below could result in falling film evaporator or PHR BPHE damage.

# Pre-Start Checkout

## Prestart procedures

### ⚠ WARNING

#### Hazardous Voltage!

Disconnect all electrical power, including remote disconnects before servicing. Follow proper lockout / tagout (LOTO) procedures to ensure the power cannot be inadvertently energized. Failure to disconnect power before servicing could result in death or serious injury.

When installation is complete, but prior to putting the unit into service, the following prestart procedures must be reviewed and verified correct. Fill in [Table 7. RTX-C-XE/XE-HSE Pre-Start Check List](#).

1. Inspect all wiring connections to be correct and tight.

### NOTICE

#### Equipment Damage!

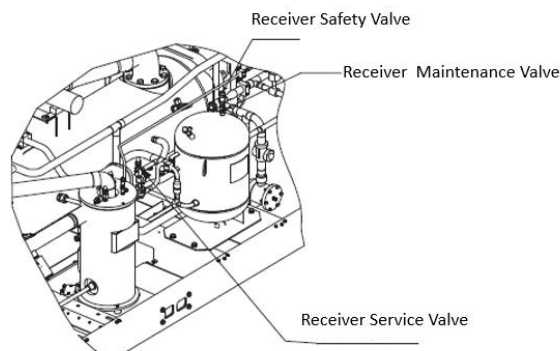
Inspect and confirm all the terminal blocks and the power line connections (disconnects, terminal block, contactors, compressor junction box terminals and so forth) clean and tight to avoid terminal connections overheating and compressor motor under voltage and eventually fail.

For HSE (variable speed) unit check the following items of drive:

Item	Description
Voltage	The voltage is 380 VAC to 480 VAC and 50/60 Hz.
	The input terminals R, S, and T are correctly connected.
Connection of AC drive output terminals and motor terminals	The AC drive and motor are grounded properly.
	The AC drive output terminals U, V, and W are firmly connected to the motor terminals.
Connection of control circuit terminals of the AC drive	The AC drive output terminals U, V, and W are firmly connected to the motor terminals.
Status of AC drive control terminals	Control circuit terminals of the AC drive are firmly connected to other control devices.
	All control circuit terminals of the AC drive are OFF (the AC drive is not running).

2. Verify that all valves are in right position. Except the service valve of receiver should be closed (shown in [Figure 18. Receiver Service Valve](#)), all other valves should be fully opened prior to unit startup, including angle valve of compressor oil line (face to the valve stem, turning the stem clockwise to close, turning the stem counter-clockwise to open); liquid pipe and oil return ball valves (open/close status shown in [Figure 19](#)); maintenance valves of safety valve for oil separator and receiver (shown in [Figure 18](#)); and inlet and outlet field-supplied valves of water system.

**Figure 18. Receiver Service Valve**



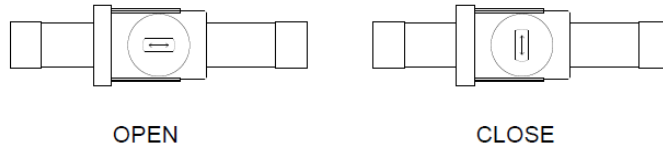
## ⚠ WARNING

### Containing Refrigerant!

Service valve of safety valve can only be close when the safety valve needs to be removed for annual check; otherwise, it should always be fully open.

Unit should be powered off during the safety valve annual check.

Figure 19. Ball Valve Open/Close Status



## NOTICE

### Equipment Damage!

Do not operate the unit when the oil line, liquid line service valves and all the manual shutoff not in right position. Failure to do so may cause serious compressor damage.

3. Check the power supply voltage to the unit at the main power fused-disconnect switch. Voltage must be within the voltage utilization range stamped on the unit nameplate. Voltage imbalance must not exceed 2 percent.
4. Check the unit power phase to be sure that it has been installed in an "ABC" sequence.

## NOTICE

### Compressor Damage!

Failure to follow applications guidelines on electrical phase rotation may result in compressor damage for RTXC-XE/XE-HSE unit.

5. Confirm all fans rotate freely.
6. Fill the chilled water circuits. Vent the system while water is being filled. Open the vents on the top of the evaporator during filling and close when filling completed.

## ⚠ CAUTION

### Proper Water Treatment!

The use of untreated or improperly treated water in the unit may result in scaling, erosion, corrosion, algae, or slime. It is recommended that the services of a qualified water treatment specialist be engaged to determine what water treatment, if any, is required. Trane assumes no responsibility for equipment failures which result from untreated or improperly treated water or saline or brackish water.

7. Prove all interlock and Interconnecting Wiring Interlock and External as described in the manual, such as water flow switch and chilled water pump interlock.
8. Start the chilled water pump to circulate of the water to vent air in the water system. Inspect all piping for leakage and make any necessary repairs.
9. With water circulating through the system, refer to [Figure 10. Evaporator Water Pressure Drop Curves](#) to adjust water flow and check water pressure drop through the evaporator meet requirement of [Table 4](#).
10. Adjust and confirm the chilled water flow switch for proper operation.
11. Stop the chilled water pump after vent air from the water system.
12. Power on the independent 230V single phase AC power source for the evaporator heater.

## NOTICE

### Evaporator Heater Damage!

Failure to connect power after filling water or remove power before draining will result in evaporator immersion heater failure.

### NOTICE

#### Equipment Damage!

Ensure all the electric heater of evaporator, the unit and water pump powered on to prevent evaporator from freezing due to low ambient temperature and refrigerant migration while unit on standby.

13. Power the unit to keep the heaters of compressor and oil separator energized. Ensure unit in the Stop mode.

### NOTICE

#### Compressor Damage!

Ensure that the oil sump heaters have been operating for a minimum of 12 hours before first startup after long time shutdown. Failure to do so may result in compressor damage.

14. Check the oil level of oil separator sump if desired.

*Note: Never to operate the compressor during oil level check.*

### NOTICE

#### Compressor Damage!

Check the compressor discharge superheat of each loop through TD7 display. The compressor discharge superheat should be larger than 1°C after 12 hours preheat of compressor and oil separator sump.

## Unit Voltage Power Supply

### ⚠ WARNING

#### Live Electrical Components!

During installation, testing, servicing, and troubleshooting of this product, it may be necessary to work with live electrical components. Have a qualified licensed electrician or other individual who has been properly trained in handling live electrical components perform these tasks. Failure to follow all electrical safety precautions when exposed to live electrical components could result in death or serious injury.

Unit voltage must meet the criteria given in the installation Electrical Section. Measure each lead of the supply voltage at the main power fused-disconnect switch for the unit. If the measured voltage on any lead is not within the specified range, notify the supplier of the power and correct the situation before operating the unit.

### ⚠ WARNING

#### Hazardous Voltage!

For variable frequency drives or other energy storing components provided by Trane or others, refer to the appropriate manufacturer's literature for allowable waiting periods for discharge of capacitors. Verify with an appropriate voltmeter that all capacitors have discharged. Failure to disconnect power or failure to discharge capacitors before servicing could result in death or serious injury.

For XE-HSE unit drive repair or maintain, it is required waiting 10 minutes after drive is powered off. Thus, residual voltage in the capacitor discharges to a safe value. Failure to comply will result in personal injury.

## ⚠ CAUTION

### Equipment Damage!

Inadequate voltage to the unit may cause control components to malfunction and shorten the life of relay contact, compressor motors and contactors.

## Unit Voltage Imbalance

Excessive voltage imbalance between the phases of a three-phase system can cause motors to overheat and eventually fail for XE(fixed speed) unit. The maximum allowable imbalance is 2 percent. Voltage imbalance is determined using the following calculations:

$$\% \text{Imbalance} = \frac{(V_x - V_{ave}) \times 100}{V_{ave}}$$

$$V_{ave} = \frac{(V_1 + V_2 + V_3)}{3}$$

$V_x$  = phase with greatest difference from  $V_{ave}$  (without regard to sign)

For example, if the three measured voltages are 375, 389, and 388 volts, the average would be:

$$V_{ave} = \frac{375 + 389 + 388}{3} = 384 \text{ V}$$

The percentage of imbalance is then:

$$\frac{(375 - 384) \times 100}{384} = 2.34\%$$

This exceeds the maximum allowable (2%) by 0.34 percent.

## Unit Voltage Phasing

It is important that proper rotation of the compressors be established before the unit is started. Proper motor rotation requires confirmation of the electrical phase sequence of the power supply for RTXC-XE/XE-HSE unit. The motor is internally connected for clockwise rotation when viewed from the motor end with the incoming power supply phases A-B-C. Catastrophic rotor and housing wear will occur if the compressor is driven in the reverse direction even for a very short time.

Basically, voltages generated in each phase of a polyphase alternator or circuit are called phase voltages. In a three-phase circuit, three sine wave voltages are generated, differing in phase by 120 electrical degrees. The order in which the three voltages of a three-phase system succeed one another is called phase sequence or phase rotation. This is determined by the direction of rotation of the alternator. When rotation is clockwise, phase sequence is usually called "ABC"; when counterclockwise, "CBA"

This direction may be reversed outside the alternator by interchanging any two of the line wires. It is this possible interchange of wiring that makes a phase sequence indicator necessary if the operator is to quickly determine the phase rotation of the motor.

Proper compressor motor electrical phasing can be quickly determined and corrected before starting the unit. Use a quality instrument, such as the Associated Research Model 45 Phase Sequence Indicator.

1. Check the unit in "Stop" mode from TD7 display.
2. Open the electrical disconnect or circuit protection switch that provides line power to the line power terminal block(s) in the starter panel (or to the unit mounted disconnect)
3. Connect the phase sequence indicator leads to the line power terminal, as follows:

Phase	Sea. Lead	Terminal
Black	(Phase A)	L1
Red	(Phase B)	L2
Yellow	(Phase C)	L3

4. Turn power on by closing the unit supply power fused-disconnect switch.
5. Read the phase sequence on the indicator. The "ABC" LED on the face of the phase indicator will glow if phase is "ABC"

6. If the “CBA” indicator glows instead, open the unit main power disconnect and switch two line leads on the line power terminal block(s) (or the unit mounted disconnect). Reclose the main power disconnects and recheck the phasing.

### **⚠ CAUTION**

#### **Equipment Damage!**

**Do not interchange any load leads that are from the unit contactors or the motor terminals.**

The terminal connection of the compressor after maintenance must be consistent with Trane wiring diagrams. Do not interchange any load leads that are from the unit contactors or the motor terminals to prevent compressor from damage in a reverse rotation. Do not operate compressor without terminal box cover in place.

7. Reopen the unit disconnect and disconnect the phase indicator.

## **Water System Flow Rates**

Establish a balanced chilled water flow through the evaporator within the allowable range in [Table 4](#). The flow rates should fall between the minimum and maximum values. Chilled water flow rates below the minimum values will result in laminar flow, which reduces heat transfer and causes either loss of EXV control or repeated nuisance, low temperature cutouts. Flow rates that are too high can cause tube erosion.

## **Water System Pressure Drop**

Measure water pressure drop through the evaporator at the field-installed pressure taps on the system water piping. Use the same gauge for each measurement. Do not include valves, strainers fittings in the pressure drop readings.

Pressure drop readings should be approximately those shown in [Figure 10. Evaporator Water Pressure Drop Curves](#) and [Table 4](#).





# Unit Start-up and Shut-down Procedures

**Important: Initial unit commissioning start-up must be performed by Trane, or an agent of Trane specifically authorized to perform start-up and warranty of Trane products. Contractor shall provide Trane (or an agent of Trane specifically authorized to perform start-up) with notice of the scheduled start-up at least two weeks prior to scheduled start-up.**

## Sequence of Operation

This section will provide basic information on unit operation for common events. With microelectronic controls, ladder diagrams cannot show today's complex logic, as the control functions are much more involved than older pneumatic or solid-state controls.

Adaptive control algorithms can also complicate the exact sequence of operations. This section illustrates common control sequences.

## Unit Startup

If the pre-start checkout, has been completed, the unit is ready to start.

1. Ensure the "STOP" key display on the TD7. As necessary, adjust the setpoint values on the TD7 menus using TU and record in.

### NOTICE

**Any change of the protection setpoints might result the loss of related guaranteed rights without the authorization or approval from Trane Company.**

2. Close the fused-disconnect switch for the chilled water pump.
3. Check the service valves on the oil line and liquid line for each circuit. These valves must be open before starting the compressors except the service of receiver.

### CAUTION

#### Compressor Damage!

**Catastrophic damage to the compressor will occur if the oil line shut off valve or the isolation valves are left closed on unit start-up.**

4. Power on the electrical heater of evaporator.
5. Ensure that the Uninterruptible Power Supply to the heaters of compressor oil sump and oil separator has been operating properly for a minimum of 12 hours before starting. Failure to do so may result in compressor damage.
6. Select the MODE and press the AUTO key on TD7. If the unit control calls for operation and all safety interlocks are closed, the unit will start. The compressor(s) will load and unload in response to the leaving chilled water temperature.
7. Once the system has been operating for approximately 30 minutes and has become stabilized, complete the remaining start-up procedures, as follows:
  - 1) Check the discharge pressure, suction pressure under Refrigerant Report on the TD7 display after compressor full loaded. The pressures are referenced to sea level (standard atmospheric pressure is 101.35kPa/14.6960 psia). The approach temperature should be within the range of [Table 7. Unit Operation Status](#).
  - 2) Check both suction and discharge superheat of the compressor. The discharge superheat should be always above 10°C, while the suction superheat normally in the range of 2°C ~ 6°C at heating mode.
  - 3) Measure the system subcooling. Bubbles in the EXV sight glasses indicate either low refrigerant charge or excessive pressure drop in the liquid line or a stuck open expansion valve. A clear sight glass alone does not mean that the system is properly charged. Also check system subcooling, liquid level control and unit operating pressures.

If the operating pressures, sight glass, superheat and subcooling readings indicate a refrigerant shortage, leak check the unit and confirm using soap bubbles and repair all the leaks prior to gas-charge refrigerant into circuit until operating conditions become normal.

**Table 7. Unit Operation Status**

Operation Mode		Water side approach temperature range (°C)		Air side approach temperature range (°C)
Cooling	2~4	Leaving water temperature – Saturated suction temperature	15~20	Saturated discharge temperature – Outdoor air temperature
Heating	2~6	Saturated discharge temperature – Leaving water temperature	8~12	Outdoor air temperature – Saturated suction temperature

### **NOTICE**

#### **Equipment Damage!**

Use only refrigerants specified on the unit nameplate and Trane OIL00388. Failure to do so may cause compressor damage and improper unit operation.

### **⚠ CAUTION**

#### **Personal Injury!**

Avoid breathing refrigerant vapor and any contact with liquid or gas. Vaporizing refrigerant liquid causes rapid cooling and contact may cause cold burns, frostbite, even through normal gloves.

### **NOTICE**

#### **Efficiency Decline!**

Each RTX-C-XE/XE-HSE unit is factory leak-tested, refrigerant charged and tested for proper operations prior to shipment. The shipment is made with a waiting charge and should be completed by refrigerant charge on site. Identify and repair eventual leak points before field charge to avoid refrigerant over charge and excessive power consumption.

## **Unit Shutdown**

### **Temporary Shutdown and Restart**

To shut down for a short time is used for control operation, maintenance or to repair the unit, use the following procedure.

1. Press the STOP key on the TD7. The compressors will continue to operate and, after unloading for 20 seconds, will stop all the compressor and the fans as well.
2. Ensure that power is always available to the unit and Symbio 800 controlled pump, even during the off-season, so that to energize pump and circulate water to prevent evaporator from freezing during low ambient temperature and refrigerant migration. Also make sure that the evaporator anti-freeze heaters have power.
3. Press the AUTO key to restart the unit in previous mode.

### **NOTICE**

#### **Equipment Damage!**

When unit is in temporary shutdown, Symbio 800 controlled water pump and evaporator heater combination will protect the evaporator from freezing during to low ambient temperature and refrigerant migration.

This option will NOT protect the evaporator in the event of any power failure to the unit, water pump or evaporator heaters. The Trane warranty does not cover damage due to the freezing.

### **Extended Unit Shutdown**

The following procedure is to be followed if the system is to be taken out of service for an extended period of time (i.e., seasonal shutdown):

1. Perform the normal unit stop sequence using the Stop key.

2. Open the electrical disconnect switches for the unit. Lock the switches in the "OPEN" position.
3. Remove evaporator power before draining evaporator to avoid heater burnout.
4. Open the electrical disconnect switches for the water pump. Lock the switches in the "OPEN" position.
5. Drain the chilled water system. Remove the drain and vent plugs from the evaporator waterbox to drain the evaporator.  
*Note: If unit downtime more than one month, recommend filling low pressure nitrogen to avoid pipe and evaporator shell corrosion.*
6. Drain the heat recovery water system if installed.
7. At least every three months (quarterly), check the refrigerant pressure of the unit to verify the refrigerant charge integrity.

### ***NOTICE***

#### **Evaporator Heater Damage!**

**To prevent evaporator heater burnout, open the heater power disconnect switch before water drain.**

## **Seasonal Unit Start-up**

Pass through the Unit Prestart checkup procedures 1~14, follow the Startup to start the unit.

## Periodic Maintenance

Perform all maintenance procedures and inspections at the recommended intervals. This will prolong the life of the unit and minimize the possibility of costly failures.

An important aspect of the unit maintenance program is the regular completion of an operating log, an example of this log is provided in this manual, through TD7 interface shown in [Figure 20](#) and [Figure 21](#). When filled out properly the completed logs can be reviewed to identify any developing trends of operating conditions and prevent possible failure of the unit.

## Weekly Maintenance and Checks

After the unit has operated for approximately 30 minutes and the system has stabilized, check the operating conditions, and complete the procedures below:

1. Log the unit.
2. Check compressor discharge and suction pressures with gauges and compare to the reading on the TD7. Pressure readings should fall within the specified ranges listed in [Table 7](#). If unit measurements vary significantly from values listed in the table, problems may exist with refrigerant charge levels. Contact your local Trane Service Agency.
3. Observe and clean the air side fin-tube heat exchanger if blocked.
4. Record the water pressure drop across the evaporator. Clean water strainer if necessary.
5. Check the temperature differential between the two sides of the refrigerant filter and oil return filter. Replace the filter element if necessary.
6. Inspect the entire system for unusual conditions and repair if needed.
7. Inspect and clean dirt or dust on ventilation screen on starter panel for RTX-C-XE-HSE unit.
8. Inspect the ventilation fan of starter panel and drive for RTX-C-XE-HSE unit.

### **NOTICE**

**Each RTX-C-XE/XE-HSE unit is factory leak-tested, refrigerant charged and tested for proper operations prior to shipment. Identify and repair the leak point before field charge to avoid refrigerant over charge and excessive power consumption.**

## Monthly Maintenance and Checks

1. Review operating log.
2. Perform all weekly maintenance procedures.
3. Measure the system subcooling.
4. Record the system superheat.
5. Clean water strainers in the chilled water piping systems if needed.
6. Inspect power cables and connections, whether insulation aging or wear, connection loose.
7. Clean dirt or dust on ventilation screen on control panel for RTX-C-XE-HSE unit.
8. Inspect the ventilation fan of control panel and drive for RTX-C-XE-HSE unit.

## Annual Maintenance

### **⚠ WARNING**

#### **Hazardous Voltage!**

**Disconnect all electric power, including remote disconnects. Follow proper lockout/tagout procedures to ensure the power cannot be inadvertently energized. Failure to disconnect power before servicing could result in death or serious injury.**

1. Perform all weekly and monthly maintenance procedures.
2. Check the pressure drop of internal oil filter, and temperature difference on liquid line.
3. Check the oil level of oil separator while the unit is off.

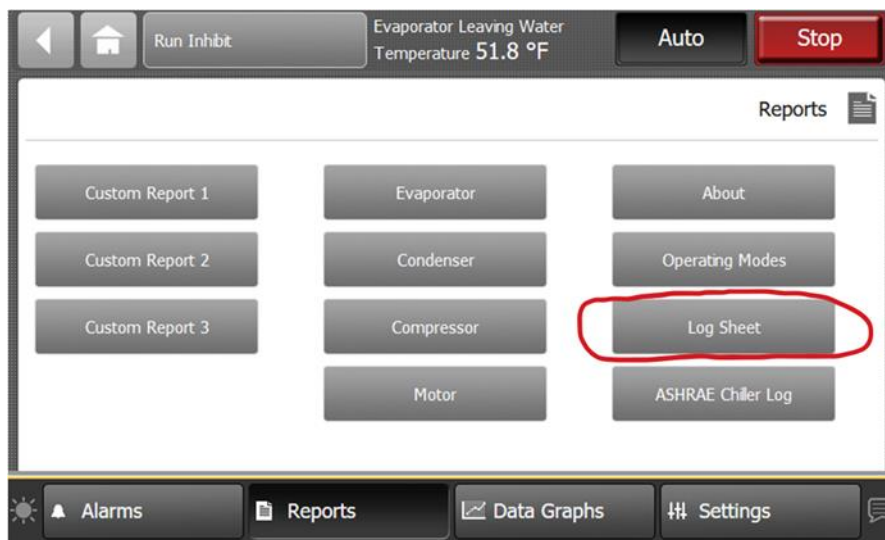
***Note:** Routine changing of the oil is not required. Have a qualified laboratory perform an oil analysis to determine system moisture content and acid level.*

4. Contact a qualified service organization to leak test the unit, to check operating and safety controls, and to inspect electrical components for deficiencies.
5. Clean and repaint any areas that show signs of corrosion.
6. Inspect all piping components for leakage and/or damage. Clean all water strainers.
7. Inspect the air side heat exchanger. Clean if necessary.
8. Inspect the evaporator tubes for fouling. Clean if necessary.
9. Clean the condenser fans. Manually rotate the condenser fans to ensure all the fans can rotate freely.
10. Check and tighten all electrical connections as necessary.
11. Inspect the entire system for unusual conditions.
12. Check life of fans and electrolytic DC bus capacitors of drive for RTXC-XE-HSE unit. Reference drive manual to replace fan or capacitors.

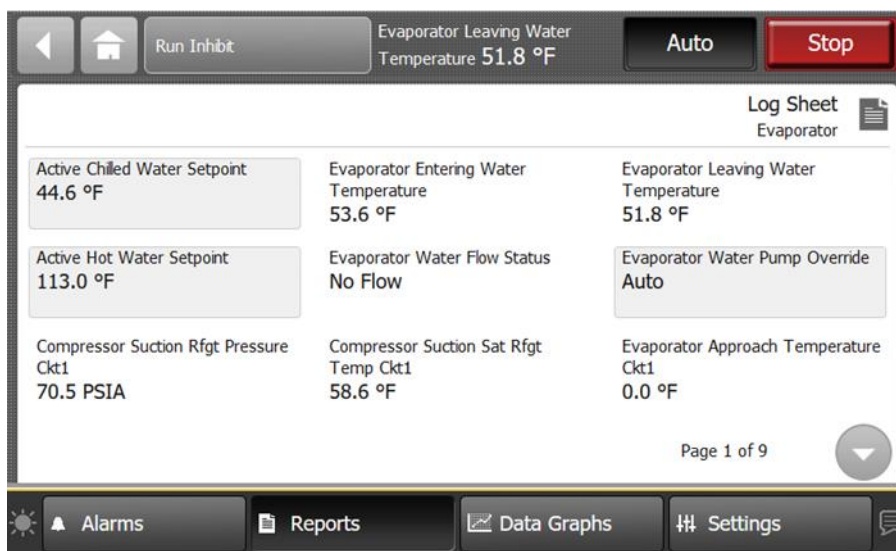
## TD7 Log

Refer to following [Figure 20](#) and [Figure 21](#), Operator Log can be captured on TD7.

**Figure 20. Report**



**Figure 21. Log Sheet**



**Table 8. RTX-XE/XE-HSE Pre-Start Check List**

<b>RTXC-XE/XE-HSE Start Up Test Log</b>								
Jobsite Name:			Jobsite Location:					
Unit Model #:		Unit Serial #:		Start Date:				
Sales Order #:	Ship Date:		Jobsite Elevation (m. above sea level):					
<b>Power Supply</b>			<b>Unit Status (before Start-up)</b>					
Voltage (V):			Chiller Appearance at Arrival:					
Frequency (Hz):			Pressure from TD7 (bar): Ckt1:		Ckt2:			
Phase Imbalance Rate (%):			R134a/R513A Charge (kg): Ckt1:		Ckt2:			
<b>Compressor Data</b>								
Circuit 1	Compressor 1A	Serial #:		Circuit 2	Serial #:			
		Model #:			Model #:			
		Series #:			Series #:			
		RLA (A)			RLA (A)			
		Power (kW)			Power (kW)			
	Compressor 1B	Serial #:			Compressor 2B		Serial #:	
		Model #:					Model #:	
		Series #:					Series #:	
		RLA (A)					RLA (A)	
		Power (kW)					Power (kW)	
<b>Evaporator Design Conditions</b>			<b>Evaporator Actual Conditions</b>					
Water Flow Rate (m³/h):			Water Flow Rate (m³/h):					
Entering Temp (°C):	Leaving Temp (°C):		Entering Temp (°C):	Leaving Temp (°C):				
<b>Options Installed</b>								
Communications Interface Type:								
Other:								
Other:								
Owner Witness Signature:								



# Maintenance and Service

## Refrigerant Field Charge Procedure

Once the system is deemed leak and moisture free, following the procedures to add refrigerant charge. Refer to [Figure 1. Unit Nameplate](#) for refrigerant charge information.

1. Unit is empty of all refrigerant and under vacuum.
2. Attach charge hose to evaporator service valve and exclude the air in hose by refrigerant prior to open the service valve.
3. Add charge to the evaporator according to the refrigerant type and amount indicated in the unit nameplate.
4. Close the service valve and remove the charge hose after charge.

### ⚠ CAUTION

#### **Equipment Damage!**

Constant water flow within allowed range through the evaporator is strictly necessary during the whole charge process to prevent evaporator from freezing damage.

### NOTICE

#### **Equipment Damage!**

Ensure that the oil sump heaters have been operating for a minimum of 12 hours before starting and power of evaporator heater and pump always on. Failure to do so may result in equipment damage.

## Refrigerant Field Charge to an Undercharged Unit

This procedure should be followed when adding refrigerant to an undercharged unit.

1. Once the system is deemed shortage, refer to [Figure 17](#), loosely attach charge hose to the service valve of suction side of the unit with the R134a/R513A tank.
2. Open the valve of refrigerant tank to evacuate the air in the charging hose.
3. Add no more than 4.5kg gas refrigerant into the circuit during compressor operation.
4. After the unit has operated for approximately 30 minutes and the system has stabilized, check the subcooling and approach temperature. Repeat from Step 3 till subcooling or approach temperature back to normal.
5. Close the service valve and remove the hose.

### NOTICE

#### **Insufficient Subcooling!**

Proper subcooling can be determined by operator log, service technician experience or consulting Trane local service.

### NOTICE

#### **Gas Refrigerant Adding!**

Add gas refrigerant only during operation to avoid compressor failure.

## Refrigerant Recycling

Refrigerant used in any type of air-conditioning or refrigerating equipment should be recovered and/or recycled for reuse, reprocessed (reclaimed). Recover the system refrigerant charge should use certified recycling equipment and approved storage containers for recycled refrigerant follow proper procedure. Never release refrigerant into the atmosphere or discharge refrigerant into the container by compressor operation of the unit.

Recover the refrigerant through the service port of liquid line and evaporator. The following information is to be noted for refrigerant recovery.

- Only trained and qualified service personnel should recover refrigerant with Personal Protective Equipment (PPE).
- The workplace shall be well ventilated, away from inflammable and explosive materials, rain, and moisture.
- Disconnect all electric power of the unit and lockout before refrigerant recovery.
- Use only approved storage container for recycled refrigerant. To prevent on-side over filling, the safe filling level must be controlled by weight and must not exceed 60% of container gross weight rating. Comply with all applicable transportation standards when shipping refrigerant container.

## Refrigerant Filter Replacement Procedure

A dirty filter is indicated by a temperature gradient across the filter, corresponding to a pressure drop. If the temperature downstream of the filter is 2.22°C lower than the upstream temperature, the filter should be replaced. A temperature drop can also indicate that the unit is undercharged. Ensure proper subcooling before taking temperature readings.

1. Normal Stop the unit, manually close all EXVs by TD7. Disconnect all electric power of unit and lockout.
2. Close liquid line isolation valve.
3. Attach hose to service port on liquid line filter flange.
4. Evacuate refrigerant from liquid line and store.
5. Depress schrader valve to equalize pressure in liquid line with atmospheric pressure.

***Note:** Continue with the next steps unless confirmed that the pressure of liquid line equalized with atmospheric pressure, otherwise should recover refrigerant of the whole system before next.*

6. Remove bolts that retain filter flange.

### **⚠ WARNING**

#### **Contains Refrigerant!**

**System contains oil and refrigerant under high pressure. Recover refrigerant to relieve pressure before opening the system.**

**Failure to follow proper procedures could result in death or serious injury or equipment damage.**

7. Remove old filter element
8. Inspect replacement filter element and lubricate O-ring with Trane OIL00388.

***Note:** Do not use mineral oil. It will contaminate the system.*

9. Install new filter element in filter housing.
10. Inspect flange gasket and replace if damaged.
11. Install flange and torque bolts to 19-22 Nm (14-16 lb-ft).
12. Attach vacuum hose and evacuate liquid line.
13. Remove vacuum hose from liquid line and attach charging hose.
14. Replace stored charge in liquid line.
15. Remove charging hose.
16. Open liquid line isolation valve.

## Compressor Oil

### **⚠ CAUTION**

#### **Compressor Damage!**

**Use only Trane OIL00388. Failure to do so may cause compressor damage and improper unit operation.**



Trane Polyolester Oil is the approved oil for the RTX-C-XE/XE-HSE units. Polyolester oil is extremely hygroscopic meaning it readily attracts moisture. The oil cannot be stored in plastic containers due to the hygroscopic properties. As with mineral oil, if water is in the system it will react with the oil to form acids. Use [Table 9](#) to determine the acceptability of the oil.

**Table 9. POE Oil Properties**

Description	Acceptable Levels
Moisture content	less than 300 ppm
Acid Level	less than 0.5 TAN (mg KOH/g)

## Replacing the Oil Filter

The filter element should be changed if the oil flow is sufficiently obstructed, or oil analysis failed. Two things can happen: first, the unit may show an “Oil Filter Change Recommended” warning message, or secondly, the compressor may shut down on a “Low Oil Flow” diagnostic.

## Fin-tube Coil Cleaning

Clean the fin-tube coils at least once a year or more frequently if the unit is in a “dirty” environment. A clean coil will help to maintain unit operating efficiency. Follow the detergent manufacturer's instructions to avoid damaging the coils.

To clean the coils, use a soft brush and a sprayer such as a garden pump type or a high-pressure type. A high-quality detergent such as Trane Coil Cleaner (Part No. CHM-00255) is recommended. See RTAC-SVG01B-EN for maintenance and cleaning procedures.

***Note:** If detergent mixture is strongly alkaline (pH value greater than 8.5, an inhibitor must be added).*

### **⚠ WARNING**

#### **Hazardous Chemicals!**

Coil cleaning agents can be either acidic or highly alkaline and can burn severely if contact with skin occurs. Handle chemical carefully and avoid contact with skin. **ALWAYS** wear Personal Protective Equipment (PPE) including goggles or face shield, chemical resistant gloves, boots, apron, or suit as required. For personal safety refer to the cleaning agent manufacturer's Materials Safety Data Sheet and follow all recommended safe handling practices. Failure to follow all safety instructions could result in death or serious injury or equipment damage.

## Water Side Heat Exchanger Maintenance

### **⚠ CAUTION**

#### **Proper Water Treatment!**

The use of untreated or improperly treated water in a RTX-C may result in scaling, erosion, corrosion, algae, or slime. It is recommended that the services of a qualified water treatment specialist be engaged to determine what water treatment, if any, is required. The Trane Company assumes no responsibility for equipment failures which result from untreated or improperly treated water, saline or brackish water.

Since the water side heat exchanger is typically part of a closed circuit, it does not accumulate appreciable amounts of scale or sludge. However, if cleaning is deemed necessary, use the cleaning methods recommended as following.

- Use a nondestructive tube test to inspect the evaporator tubes at 3-year intervals.

***Note:** It may be desirable to perform tube tests on these components at more frequent intervals, depending upon unit application. This is especially true of critical process equipment.*

- Tube fouling is suspect when the approach temperature is higher than predicted. Standard water applications will operate with less than a 5.6°C (10°F) approach. If the approach exceeds 5.6°C (10°F) cleaning the tubes is recommended.

If the annual tube inspection indicates that the tubes are fouled, two cleaning methods can be used to rid the tubes of contaminants. The methods are:

## Mechanical Cleaning Procedure

Mechanical tube cleaning method is used to remove sludge and loose material from smooth-bore tubes.

Review mechanical space limitations and determine the safest method or methods of rigging and lifting the Waterboxes.

1. Disconnect water pipes, if connected. Mind the temperature sensor and insulation.
2. Select the proper lift connection device from [Table 10. Main Components Weights](#). The rated lifting capacity of the selected lift connection device must meet or exceed the published weight of the waterbox.
3. Ensure the lift connection device has the correct connection for the waterbox.
4. Remove waterbox bolts and lift the waterbox away from the shell.

### WARNING

#### Heavy Objects!

Failure to properly lift waterbox could result in death or serious injury.

5. Store waterbox in a safe and secure location and position.

*Note: Do not leave waterbox suspended from lifting device.*

### WARNING

#### OVERHEAD HAZARD!

Never stand below or in close proximity to heavy objects while they are suspended from, or being lifted by, a lifting device. Failure to follow these instructions could result in death or serious injuries.

6. Work a round nylon brush (1 inch) attached to a rod in and out of each of the water tubes to loosen the sludge. Do not use steel wire brush to avoid tube damage. Thoroughly flush the condenser water tubes with clean water.

*Note: To clean internally enhanced tubes, use a bi-directional brush or consult a qualified service organization for recommendations.*

7. Reassembly. Once service is complete, the waterbox should be reinstalled on the shell following all previous procedures in reverse. Use new O-rings or gaskets on all joints after thoroughly cleaning each joint. Torque bolts in a star pattern to 88Nm(65ft-lbs).
8. Reconnect the external water pipes and water temperature sensors.
9. Perform water piping leakage test and recover the insulation.

*Note: Do not allow pressure to exceed water side maximum working pressure indicated on the evaporator nameplate.*

**Table 10. Main Components Weights**

Model	Compressor (kg)	Oil Separator (kg)	Water Side Heat Exchanger (kg)	Air Side Heat Exchanger (kg)		Fan Assembly (kg)	Reversing Valve (kg)	Receiver (kg)	Control Panel (kg)	Waterbox (kg)	
				Vertical	Slab					Inlet Water Side	Return Water Side
RTXC 110XE	692	86	707	183	187	54	25	79	185	35	19
RTXC 110HSE	692	86	707	183	187	54	25	79	315	35	19
RTXC 130/140HSE	692	86	707	183	187	54	25	79	367	35	19
RTXC 160/180XE	692	86	910	160	164	54	22	79	191	41	15
RTXC 160/180HSE	692	86	910	160	164	54	22	79	356	41	15
RTXC 200/220XE	692	86	1003	183	187	54	25	79	191	41	15
RTXC 200/220HSE	692	86	1003	183	187	54	25	79	367	41	15
RTXC 250/280HSE	692	86	1003	183	187	54	25	79	445	41	15
RTXC 310XE	692	86	707/1003	183	187	54	25	79	185/191	35/41	19/15
RTXC 310HSE	692	86	707/1003	183	187	54	25	79	315/367	35/41	19/15
RTXC 330XE	692	86	707/1003	183	187	54	25	79	185/191	35/41	19/15
RTXC 330HSE	692	86	707/1003	183	187	54	25	79	315/367	35/41	19/15
RTXC 360XE	692	86	910/1003	160/183	164/187	54	22/25	79	191	41	15
RTXC 360HSE	692	86	910/1003	160/183	164/187	54	22/25	79	356/367	41	15
RTXC 400/440XE	692	86	1003	183	187	54	25	79	191	41	15
RTXC 400/440HSE	692	86	1003	183	187	54	25	79	367	41	15
RTXC 500/560HSE	692	86	1003	183	187	54	25	79	445	41	15

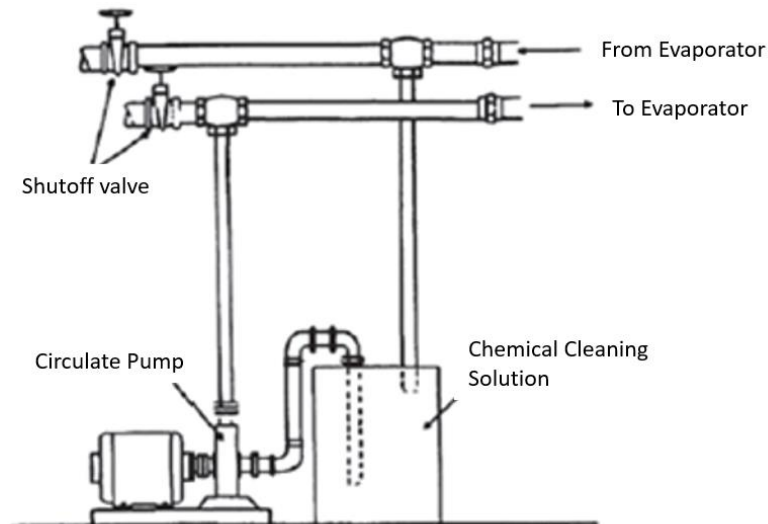
**Note:** all data is the weight of single component.

## Chemical Cleaning Procedure

Scale deposits are best removed by chemical means. Consult qualified water treatment specialist for a recommended cleaning solution. A standard chilled water circuit is composed solely of copper, cast iron and steel. Improper chemical cleaning can damage tube walls. All the materials used in the external circulation system, the quantity of the solution, the duration of the cleaning period, and any required safety precautions should be approved by the company furnishing the materials or performing the cleaning. Figure 22 shown the typical backflushing unit of the evaporator.

**Note:** Chemical tube cleaning should always be followed by mechanical tube cleaning.

**Figure 22. Chemical Cleaning**



# AC Drive (Only for RTX-C-XE-HSE)

**⚠ WARNING**

**Hazardous Voltage w/Capacitors!**  
 Failure to disconnect power and discharge capacitors before servicing could result in death or serious injury. Disconnect all electric power, including remote disconnects and discharge all motor start/run capacitors before servicing. Follow proper lockout/ tagout procedures to ensure the power cannot be inadvertently energized. For variable frequency drives or other energy storing components provided by Trane or others, refer to the appropriate manufacturer's literature for allowable waiting periods for discharge of capacitors. Verify with an appropriate voltmeter that all capacitors have discharged.

## AC Drive Programming

Field replacement drives must be programmed via the keypad interface. Program parameters sequentially by ID values as defined in tables below.

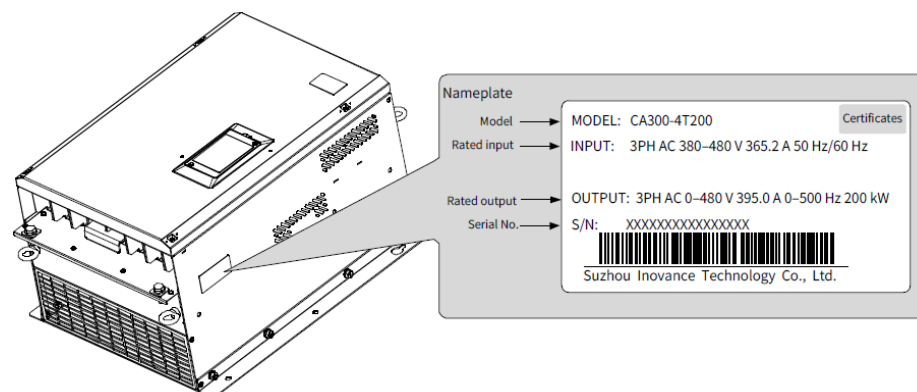
**Table 11. AC Drive Parameter Settings**

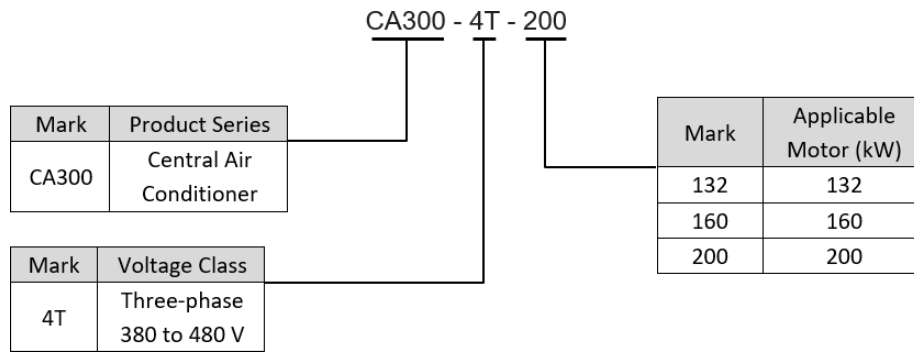
Unit Size		160/180T	110/200/ 220T	130/140/ 250/280T
ID	Description	132kW Setting	160kW Setting	200kW Setting
F0-01	Motor 1 control mode	2	2	2
F0-02	Command source selection	2	2	2
F0-03	Main frequency reference setting channel selection	9	9	9
F0-10	Max. frequency	50	50	70
F0-12	Frequency reference upper limit	50	50	70
F0-14	Frequency reference lower limit	30	30	30
F0-15	Carrier frequency	2	2	2
F0-17	Acceleration time 1	6	6	6
F0-18	Deceleration time 1	20	20	20
F1-01	Rated motor power	121.3	145.2	172.8
F1-02	Rated motor voltage	400	400	380
F1-03	Rated motor current	161	192	234
F1-04	Rated motor frequency	50	50	60
F1-05	Rated motor speed	2980	2980	3580
A4-00	Power calculation method selection	1	1	1
A4-04	Power correction coefficient	97.3	97.3	97.3
F4-01	DI2 function selection	0	0	0
F5-02	Relay 1 function selection	1	1	1
F5-03	Relay 2 function selection	0	0	0
F6-10	Stop mode	1	1	1
Fd-00	Modbus baud rate	9	9	9
Fd-01	Modbus data format	1	1	1
Fd-02*	Modbus local address	1	1	1
Fd-04	Modbus communication timeout	15	15	15

\* Fd-02=1 for CKT1 AC drive, Fd-02=2 for CKT2 AC drive.

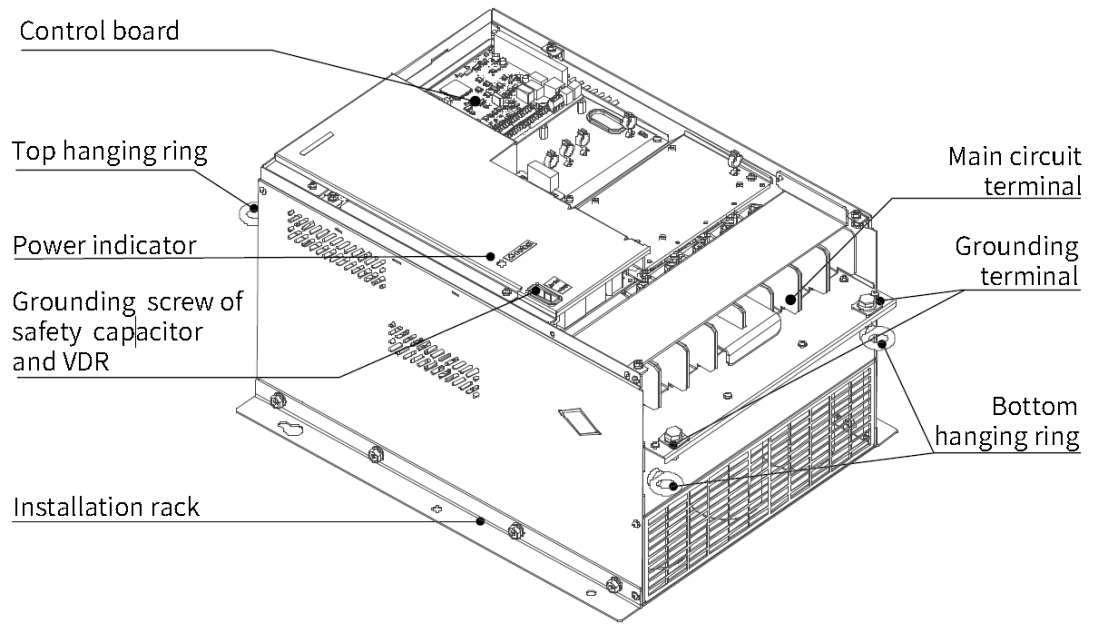
## Product Information

**Figure 23. Nameplate and Model Description**

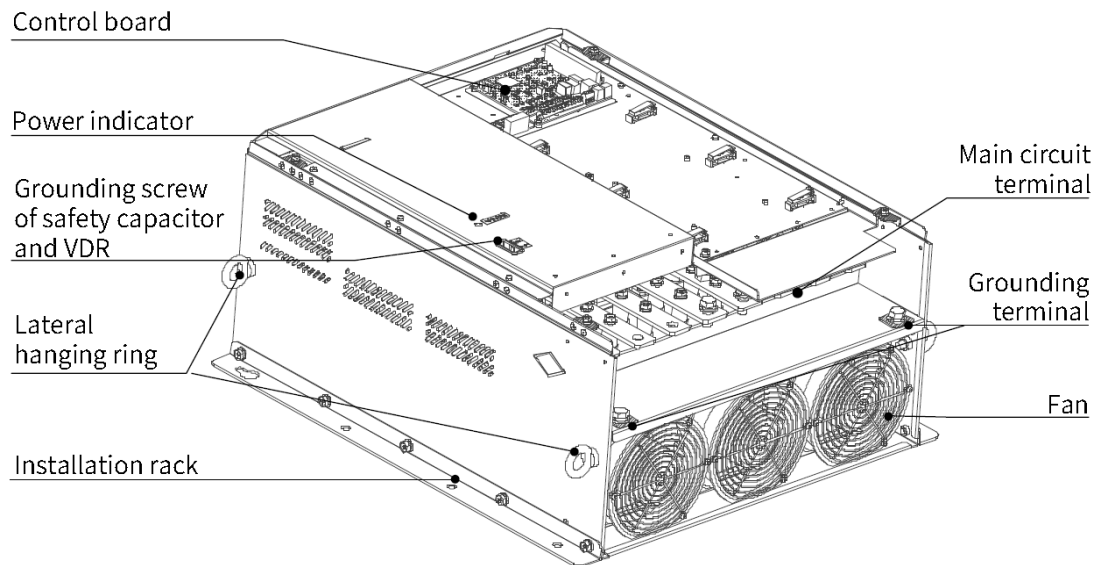




**Figure 24. AC Drive Components (132/160kW)**



**Figure 25. AC Drive Components (200kW)**



# Product Appearance and Dimensions

Figure 26. Appearance and Dimensions of CA300 Drive (132/160kW)

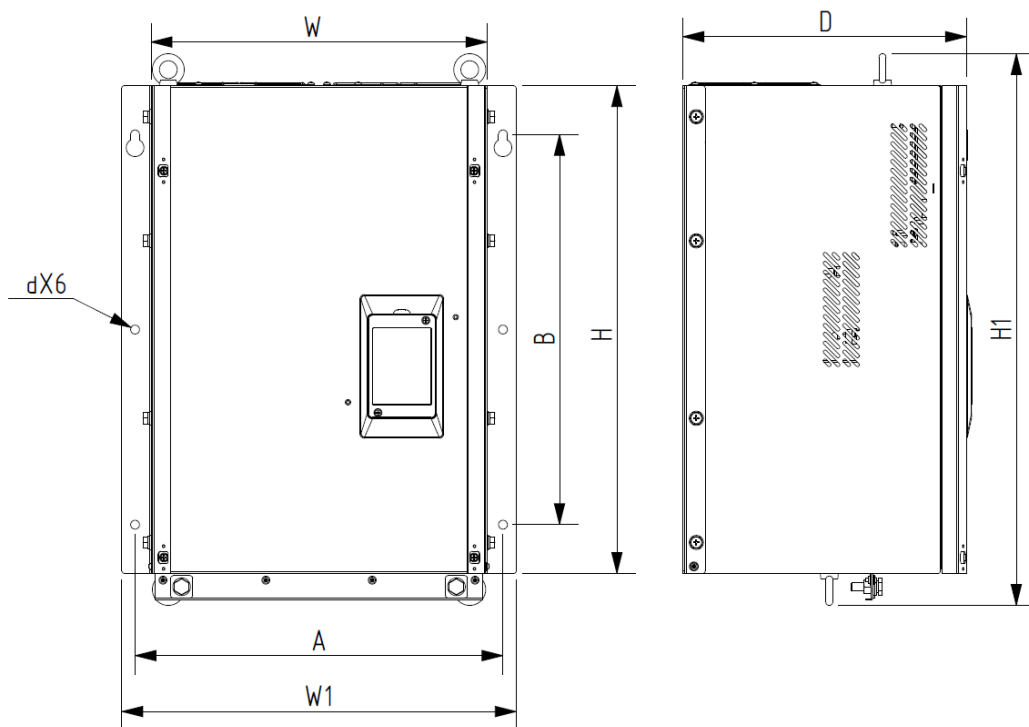


Figure 27. Appearance and Dimensions of CA300 Drive (200kW)

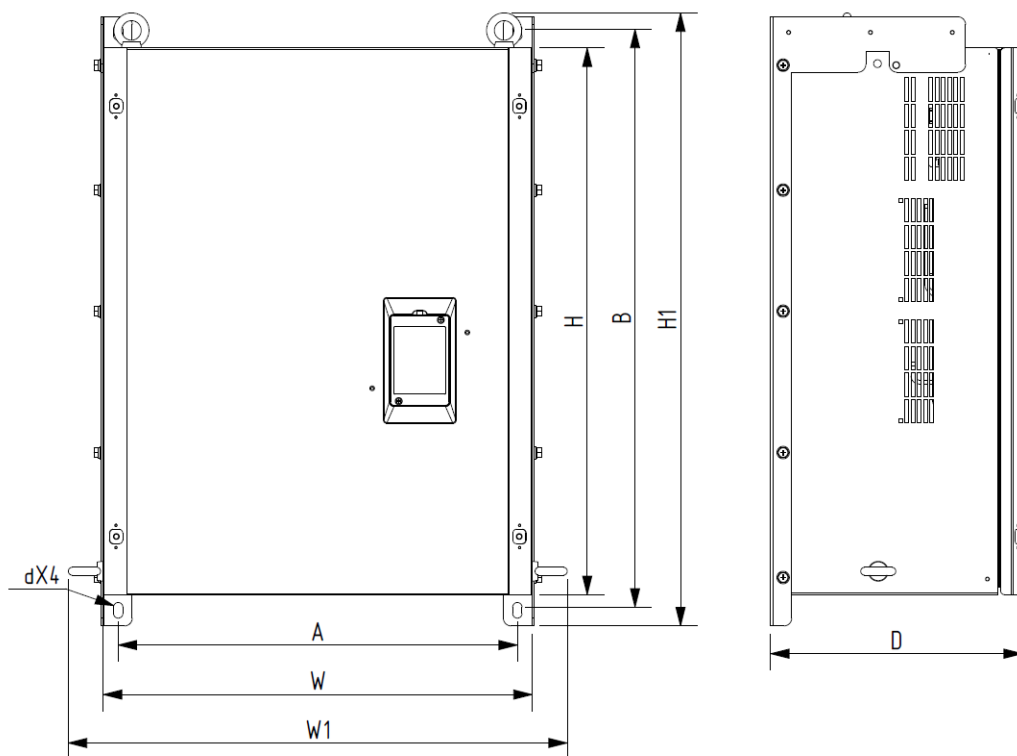


Table 12. Dimensions of CA300 Drive (132/160/200kW)

Model	Mounting Hole (mm)		Dimensions (mm)				Mounting Diameter d (mm)	Weight (kg)
	A	B	W	W1	H	H1		
CA300-4T132	415	440	375	445	550	622	Φ10	46
CA300-4T160	512	740	550	640	700	785	Φ12	89

# Technical Specifications

**Table 13. Product Models and Electrical Parameters**

Model	Power Capacity (kVA)	Input Current (A)	Output Current (A)	Motor (kW)
<b>Three-phase power supply: 380 V to 480 V (-15% to 10%) 50 Hz/60 Hz.</b>				
CA300-4T132	219	238	260	132
CA300-4T160	270	291	315	160
CA300-4T200	328	365	395	200

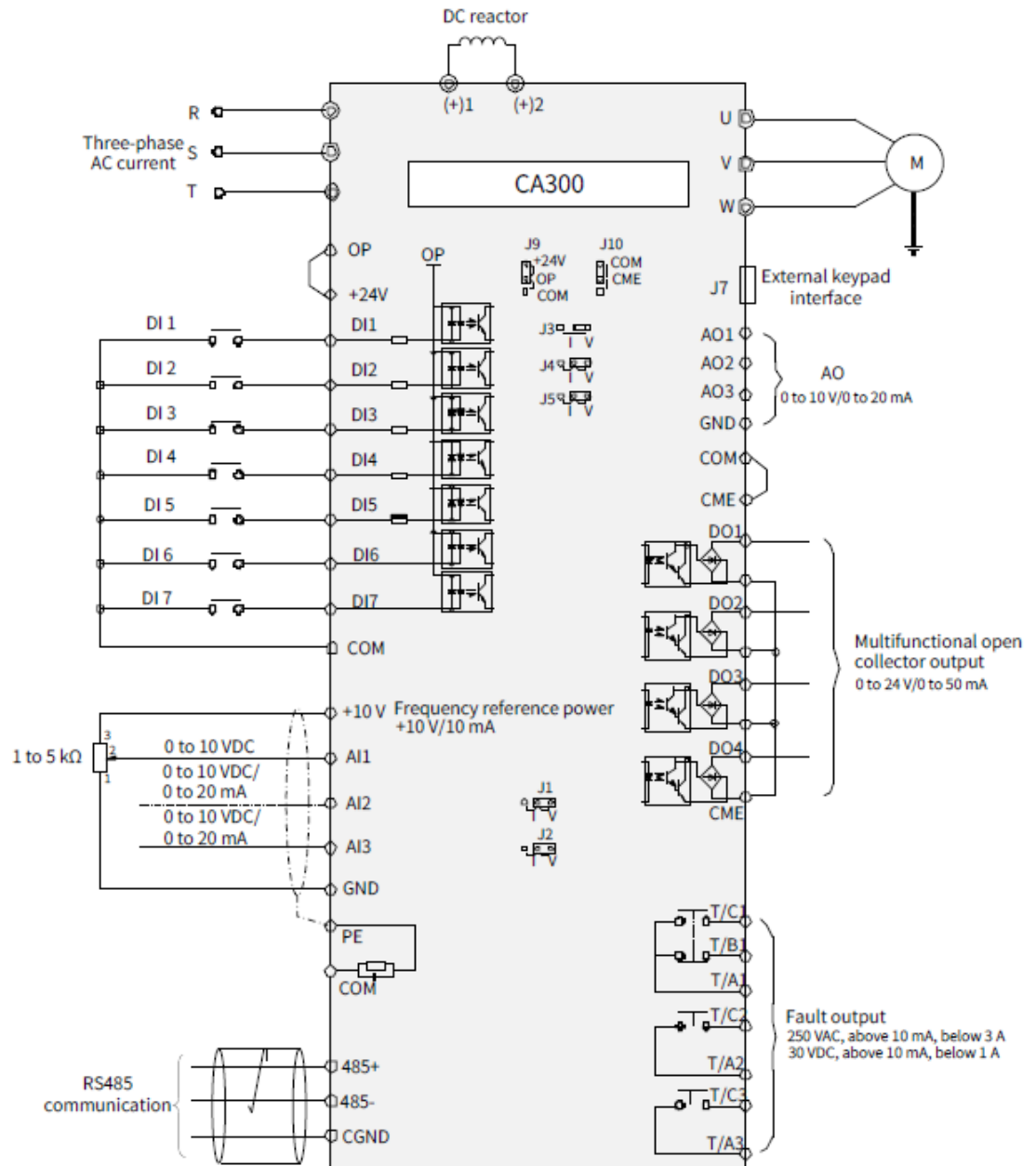
**Table 14. Parameter Table**

	Item	Description
Standard Functions	Output frequency	0 Hz to 500 Hz
	Carrier frequency	2 kHz to 8 kHz, automatically adjusted with load
	Input frequency resolution	Digital setting: 0.01 Hz Analog setting: Maximum frequency x 0.025%
	Control mode	SVC V/F
	Overload capability	110% of rated current for 60s
	Torque boost	Auto boost Customized boost 0.1 % to 30.0 %
	V/F curve	Straight-line V/F curve Multi-point V/F curve Square V/F curve Complete V/F separation Half V/F separation
	Ramp mode	Straight-line ramp S-curve ramp Four separate acceleration/deceleration time settings in the range of 0.0s to 6500.0s
	Jog running	Frequency range of jog running: 0.00 Hz to 50.00 Hz Acceleration/Deceleration time of jog running: 0.0s to 6500.0s
	Multiple preset speeds	The system implements up to eight speeds by using control terminals.
	Built-in PID	The system implements the proportional-integral-derivative (PID) function in the closed-loop control.
	Automatic voltage regulation (AVR)	The system maintains a constant output voltage automatically when the grid voltage changes through the permissible range.
	Overvoltage and overcurrent stall control	The system limits the output current and voltage automatically during operation to prevent frequent or excessive trips.
	Overcurrent fast prevention	The system minimizes overcurrent faults to ensure normal drive operation.
	Keypad and Display	Power dip ride-through
Overcurrent fast prevention		This function helps to avoid frequent overcurrent faults.
Timing control		Time range: 0.0 minutes to 6500.0 minutes
Communication bus		Modbus is supported.
LED display		Shows parameters.
Key locking and function selection		All or some keys can be locked to prevent accidental operation. The range of some key functions can be limited to a permitted range to prevent incorrect settings.
Protection		Motor short-circuit detection upon power-on, input/output phase loss protection, overcurrent protection, overvoltage protection, undervoltage protection, overheat protection, and overload protection
Command source		Allows different methods of switching between command sources: Operating panel (keypad & display) Terminal I/O control Serial communication
Main frequency reference		Supports up to 10 frequency reference setting channels and allows different methods of switching between frequency reference setting channels: Digital setting Analog voltage reference Analog current reference Pulse reference Communication reference
Auxiliary frequency reference		Supports up to 10 auxiliary frequency sources and allows fine tuning of the auxiliary frequency and main & auxiliary calculation.
Running	Input terminals	Seven DI terminals with 100 Hz maximum input frequency Three AI terminals that support 0 V to 10 V/0 mA to 20mA input and PT100 input

		Four DO terminals Three relay output terminals, one of which has NO and NC contacts and the other two have NO terminals Three AO terminals that support 0 mA to 20 mA current output or 0 V to 10 V voltage output
	Communication terminal	One RS485 communication terminal
	Installation location	Install the AC drive inside the cabinet where it is protected from direct sunlight, dust, corrosive or combustible gases, oil smoke, vapor, ingress from water or any other liquid, and salt. Install the cabinet in a basement or outdoors. Protection from direct sunlight is not mandatory.
Environment	Altitude	1500 m to 3000 m The AC drive runs properly when the altitude is below 1500 m. If the altitude exceeds 1500 m, de-rate the AC drive by 1% with increase of every 100 m.
	Ambient temperature	-20°C to +55°C If the ambient temperature exceeds 40°C, de-rate the AC drive by 1% with increase of every 1°C.
	Humidity	Less than 95% RH non-condensing
	Vibration	2 g for boards, conformance to transport standards
	Storage temperature	-25°C to +70°C
	IP rating	AC drive cabinet: IP20 AC drive: IP00
Power Grid	Applicable power grid	TN or TT

## Standard Wiring

Figure 28. Standard Electrical Wiring





# Main Circuit Terminals

Figure 29. AC Drive Terminal Arrangement

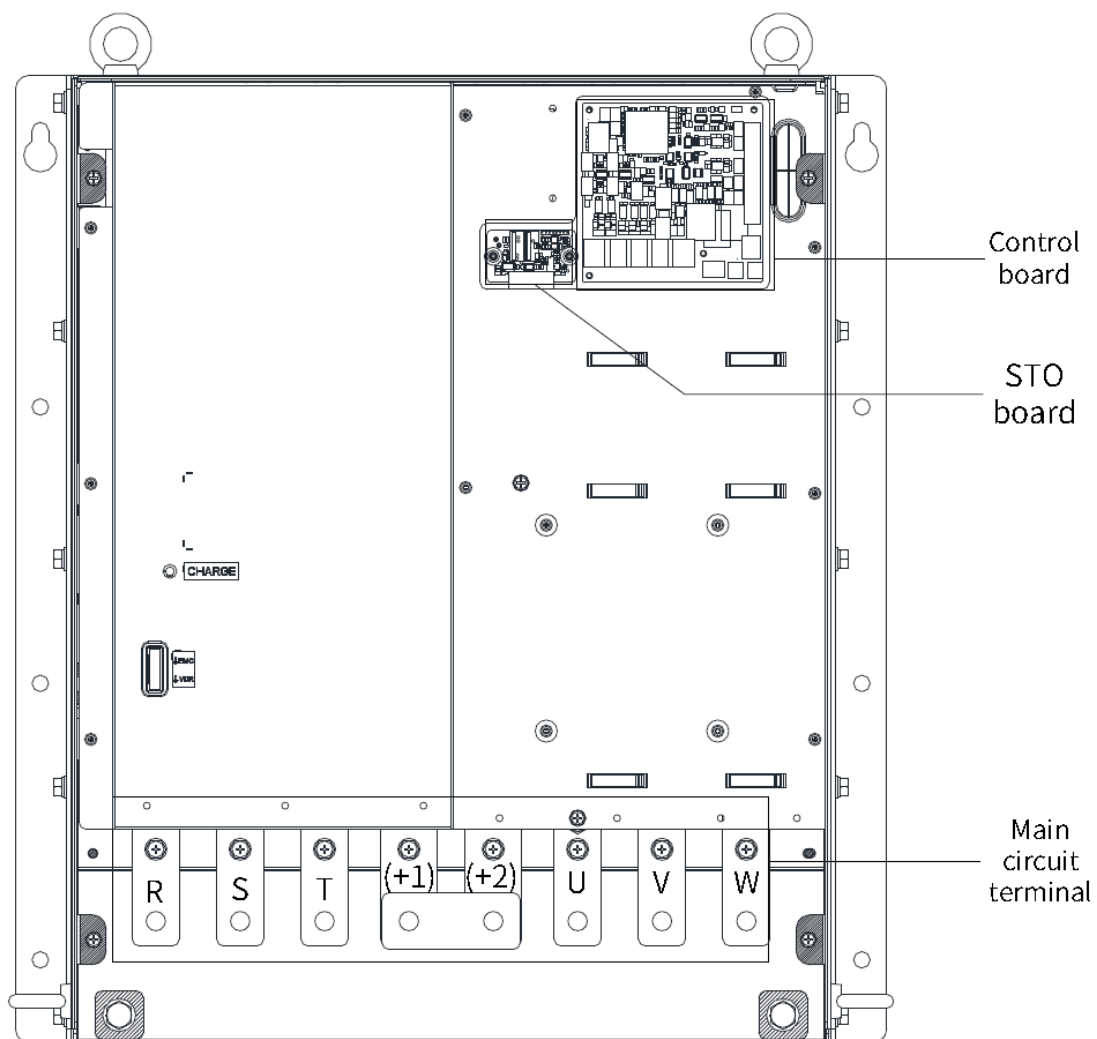
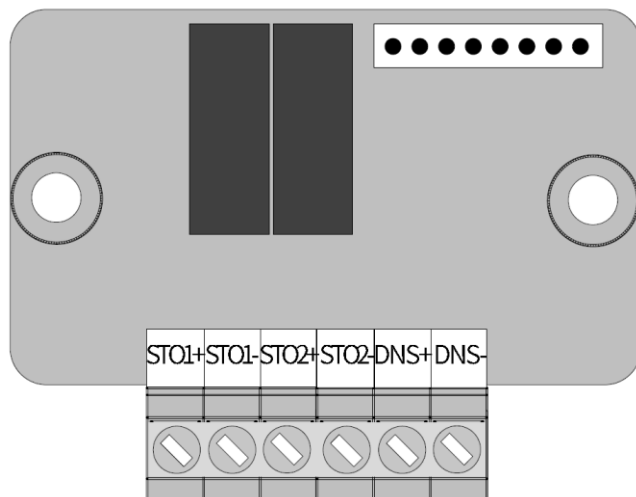


Table 15. AC Drive Terminal Arrangement

Type	Mark	Name	Function
Main Circuit	R, S, and T	Three-phase power input	Connected to the mains supply
	U, V, and W	AC drive output	Connected to the motor
	(+1) and (+2)	AC reactor connection	Connected to the DC reactor
	⊕	Grounding terminal	Grounding

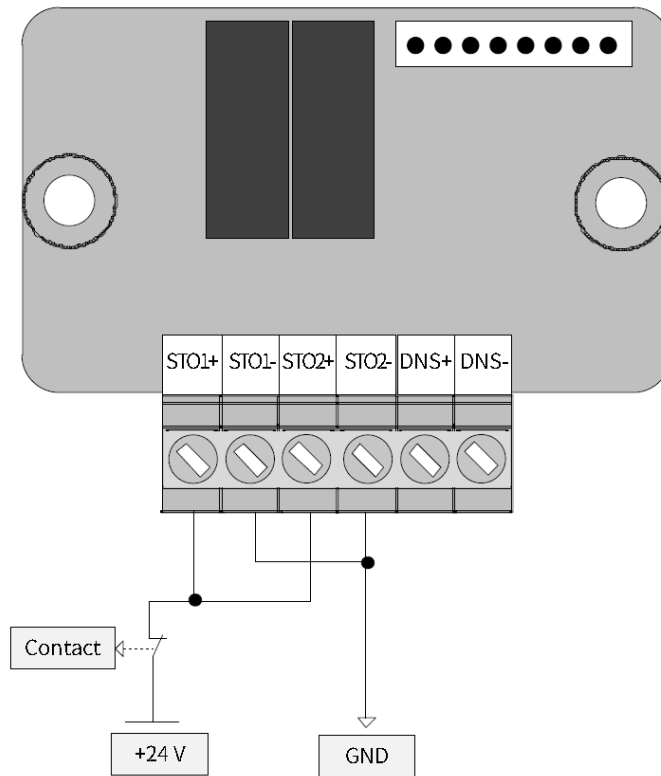
Figure 30. Layout of STO Board Terminals



**Table 16. Layout of STO Board Terminals**

Port Signal	Function	Remarks
STO1+	Positive input of the first security signal	Vin1: Voltage difference between STO1+ and STO1-
STO1-	Negative input of the first security signal	
STO2+	Positive input of the second security signal	Vin2: Voltage difference between STO2+ and STO2-
STO2-	Negative input of the second security signal	
DNS+	Positive output of external detection signal	DNS: Voltage difference between DNS+ and DNS-; OC door output
DNS-	Negative output of external detection signal	

**Figure 31. External 24V Power Supply for STO Board**

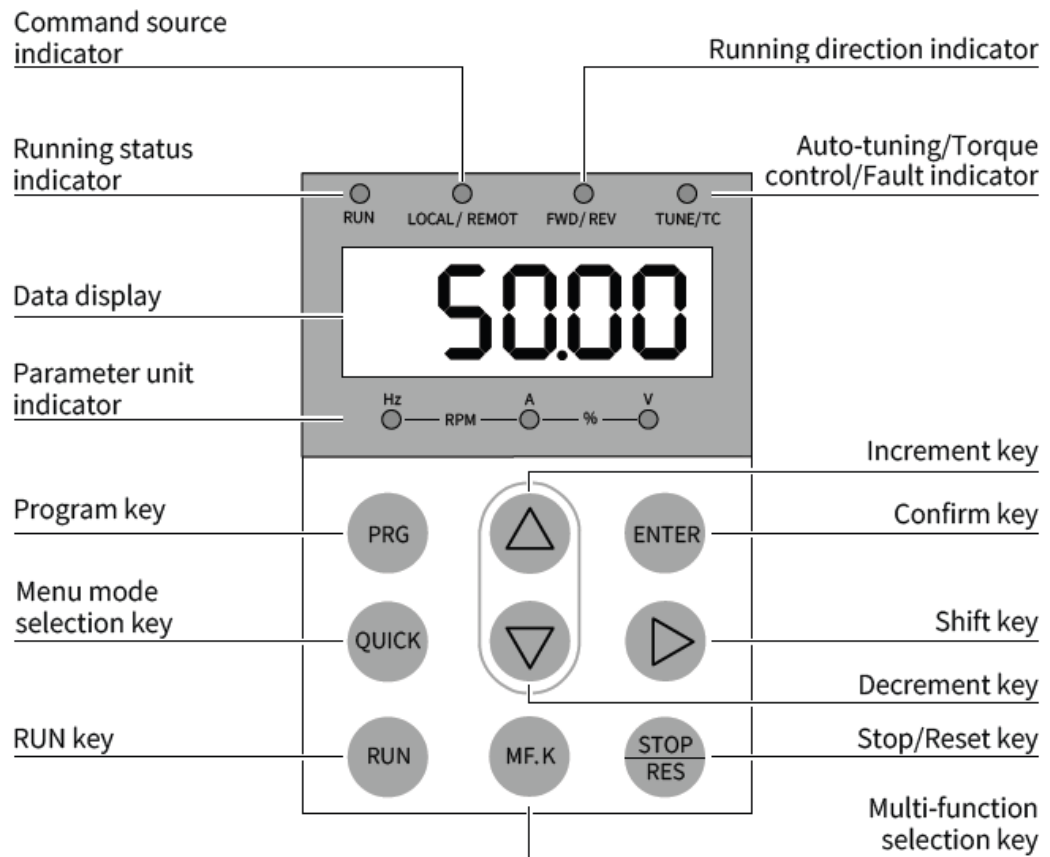


STO1+ and STO2+ are connected by NC contacts to the positive pole of the 24 V power supply. STO1- and STO2- are directly connected to the negative pole. When contacts are closed, the AC drive runs properly with 24 V input. When contacts are open, the AC drive executes an emergency stop.

# Operating Panel Introduction

Using the operating panel, you can set and modify function codes, monitor working status, and perform running control (start/stop) of the AC drive. You can also equip an external panel using the option LED operating panel (MD32NKE1).

**Figure 32. Details of Operating Panel**





## Keys on LED Operating Panel


**Table 17. Function of Keys on LED Operating Panel**

Key	Key Name	Function
	Programming	Used to enter or exit the level-1 menu.
	Confirm	Used to enter the menu interfaces level by level, and confirm the parameter setting.
	Increment	Used to increase the displayed data or parameter number.
	Decrement	Used to decrease the displayed data or parameter number.
	Shift	Used to select the displayed parameters in turn in the stop or running state and select the digit to be modified during parameter modification.
	RUN	Used to start the AC drive in the operating panel control mode.
	Stop/Reset	Used to stop the AC drive when it is in the running status or reset the AC drive when it is in the faulty status.
	Multifunction	Used to switch over between functions.
	Menu mode selection	Used to switch over between menu modes as defined by the setting of FP-03 (Selection of individualized parameter display). By default, one menu mode is set.



























# Function Indicators

 indicates the light turns on

 indicates the light turns off

 indicates the light flashes

**Table 18. Function Indicators**

Indicator Status		Description
RUN Running status indicator	 RUN	Off: STOP status
	 RUN	On: RUNNING status
LOCAL/REMOT Command source indicator	 LOCAL/ REMOT	Off: under operating panel control
	 LOCAL/ REMOT	On: under terminal control
	 LOCAL/ REMOT	Flashing: under serial communication control
FWD/REV Running direction indicator	 FWD/ REV	Off: forward motor rotation
	 FWD/ REV	On: reverse motor rotation
TUNE/TC Auto-tuning/ Torque control/Fault indicator	 TUNE/ TC	Off: normal running
	 TUNE/ TC	On: torque control mode
	 TUNE/TC	Flashing slowly: auto-tuning status (once per second)
	 TUNE/TC	Flashing quickly: fault status (four times per second)
 Hz — RPM —  A — % —  V		Frequency unit: Hz
 Hz — RPM —  A — % —  V		Current unit: A
 Hz — RPM —  A — % —  V		Voltage unit: V
 Hz — RPM —  A — % —  V		Speed unit: RPM
 Hz — RPM —  A — % —  V		Percentage (%)


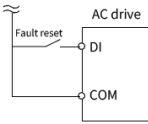


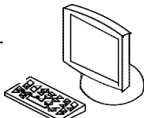
## Troubleshooting - Fault Display and Reset

Faults are handled prior to alarms.

- Example of fault code displayed: "E02.00"
- Example of alarm code displayed: "A16.13"

When a fault occurs during running, the AC drive stops output immediately, the fault indicator TUNE /TC flashes, and contact of the faulty relay acts. The following table lists faults and solutions for reference. Perform troubleshooting according to the descriptions and do not repair or modify the AC drive randomly. If the fault cannot be rectified, contact the agent or Trane.

**Table 19. Fault Display and Reset**

Stage	Solution	Remarks
After the fault occurs	Check the operating panel for detailed information of recent three faults, such as fault type and frequency, current, bus voltage, DI/DO state, accumulative power-on time and accumulative running time, IGBT temperature, and fault subcode at occurrence of the faults.	View this information using F9- 14 (1st fault type) to F9-46 (Fault subcode upon 1st fault). 
Before the fault is reset	Locate the fault cause and rectify the fault. Then follow the steps below to reset the fault.	Troubleshoot the fault according to "Faults and Diagnostics".
Fault resetting method	1) Fault resetting through a DI terminal Allocate a DI terminal with function 9 "Fault reset (RESET)" by setting any of F4- 00 (DI1 function selection) to F4-04 (DI5 function selection) to 9 (Fault reset).	
	2) Fault resetting using the operating panel Press the STOP key on the operating panel.	
	3) Automatic resetting Disconnect the power supply. Wait until the fault code disappears and connect the power supply again.	
	4) Fault resetting through communication Confirm that F0-02 (Command source selection) is set to 2 (Serial comms.) and write "7" (fault reset) to communication address 2000H using a host controller.	Host computer 

## Troubleshooting - Faults and Diagnostics

**Table 20. Faults and Diagnostics**

Fault Code	Fault Name	Cause	Possible Solution
E01.01	Hardware fault	The AC drive is abnormal in current sampling.	Check whether the main circuit is powered on. Check whether the hall sensor or current sampling circuit is damaged. If yes, contact the agent or Trane.
E01.02		The contactor is faulty.	Check the contactor.
E01.03		The braking resistor is short-circuited.	Check that the braking resistor is <i>normal</i> , and its model matches the AC drive model.
E02.00	Overcurrent during acceleration	A ground fault or short circuit exists in the output circuit of the AC drive.	Check whether short circuit occurs on the motor, motor cable, or contactor.
		The control mode is SVC, but motor auto-tuning is not performed.	Set motor parameters according to the motor nameplate and perform motor auto-tuning.
		Acceleration time is too short.	Increase acceleration time.
		The overcurrent stall prevention parameters are set improperly.	Ensure that current limit is enabled (F3-19 = 1). The setting of F3-18 (V/F current limit level) is too large. Adjust it between 110% and 140%. The setting of F3-20 (V/F current limit gain) is too small. Adjust it between 5 and 20.
		Customized torque boost or V/F curve is not appropriate.	Adjust the customized torque boost or V/F curve.
		The spinning motor is started.	Enable the flying start function or start the motor after it stops.
		The AC drive suffers external interference.	View historical fault records. If the current value is far from the overcurrent level, locate the interference source. If external interference does not exist, the drive board or hall device may be faulty.

Fault Code	Fault Name	Cause	Possible Solution
E03.00	Overcurrent during deceleration	A ground fault or short circuit exists in the output circuit of the AC drive.	Check whether short circuit occurs on the motor, motor cable, or contactor.
		The control mode is SVC, but motor auto-tuning is not performed.	Set motor parameters according to the motor nameplate and perform motor auto-tuning.
		Deceleration time is too short.	Increase deceleration time.
		The overcurrent stall prevention parameters are set improperly.	Ensure that current limit is enabled (F3-19 = 1). The setting of F3-18 (V/F current limit level) is too large. Adjust it between 110% and 140%. The setting of F3-20 (V/F current limit gain) is too small. Adjust it between 5 and 20.
		The braking unit and braking resistor are not installed.	Install the braking unit and braking resistor.
		The AC drive suffers external interference.	View historical fault records. If the current value is far from the overcurrent level, locate the interference source. If external interference does not exist, the drive board or hall device may be faulty.
E04.00	Overcurrent at constant speed	A ground fault or short circuit exists in the output circuit of the AC drive.	Check whether short circuit occurs on the motor, motor cable, or contactor.
		The control mode is SVC, but motor auto-tuning is not performed.	Set motor parameters according to the motor nameplate and perform motor auto-tuning.
		The overcurrent stall prevention parameters are set improperly.	Ensure that current limit is enabled (F3-19 = 1). The setting of F3-18 (V/F current limit level) is too large. Adjust it between 110% and 140%. The setting of F3-20 (V/F current limit gain) is too small. Adjust it between 5 and 20.
		The AC drive power class is small.	If output current exceeds rated motor current or rated output current of the AC drive during stable running, replace a drive of larger power class.
		The AC drive suffers external interference.	View historical fault records. If the current value is far from the overcurrent level, locate the interference source. If external interference does not exist, the drive board or hall device may be faulty.
E05.00	Overvoltage during acceleration	Input voltage is too high.	Adjust input voltage to normal range.
		An external force drives the motor during acceleration.	Remove the external force or install a braking resistor. The setting of F3-26 (Frequency rise threshold during voltage limit) is too small. Adjust it between 5 Hz and 15 Hz.
		The overvoltage stall prevention parameters are set improperly.	Ensure that the voltage limit function is enabled (F3-23 = 1). The setting of F3-22 (V/F voltage limit) is too large. Adjust it between 700 V and 770 V. The setting of F3-24 (Frequency gain for V/F voltage limit) is too small. Adjust it between 30 and 50.
		The braking unit and braking resistor are not installed.	Install the braking unit and braking resistor.
		Acceleration time is too short.	Increase acceleration time.
E06.00	Overvoltage during deceleration	The overvoltage stall prevention parameters are set improperly.	Ensure that the voltage limit function is enabled (F3-23 = 1). The setting of F3-22 (V/F voltage limit) is too large. Adjust it between 700 V and 770 V. The setting of F3-24 (Frequency gain for V/F voltage limit) is too small. Adjust it between 30 and 50.
		An external force drives motor during deceleration.	Remove the external force or install a braking resistor. The setting of F3-26 (Frequency rise threshold during voltage limit) is too small. Adjust it between 5 Hz and 15 Hz.
		Deceleration time is too short.	Increase deceleration time.
		The braking unit and braking resistor are not installed.	Install the braking unit and braking resistor.

<b>Fault Code</b>	<b>Fault Name</b>	<b>Cause</b>	<b>Possible Solution</b>
E07.00	Overvoltage at constant speed	The overvoltage stall prevention parameters are set improperly.	Ensure that the voltage limit function is enabled (F3-23 = 1). The setting of F3-22 (V/F voltage limit) is too large. Adjust it between 700 V and 770 V. The setting of F3-24 (Frequency gain for V/F voltage limit) is too small. Adjust it between 30 and 50.
		An external force drives the motor during running.	Remove the external force or install a braking resistor. The setting of F3-26 (Frequency rise threshold during voltage limit) is too small. Adjust it between 5 Hz and 15 Hz.
E08.00	Pre-charge resistor overload	Input voltage is not within the permissible range, causing frequent ON/OFF of contactor.	Adjust the voltage to normal range to ensure that bus voltage fluctuation does not cause frequent contactor ON/OFF.
E09.00	Undervoltage	Instantaneous power failure occurs.	Enable the power dip ride through function by setting F9-59 (Power dip ride-through function selection) to a non-zero value.
		The AC drive's input voltage is not within the permissible range.	Adjust the voltage to normal range.
		The bus voltage is abnormal.	Contact the agent or Trane.
		The rectifier bridge, the inverter drive board, or the inverter control board is abnormal.	Contact the agent or Trane.
E10.00	AC drive overload	The load is too heavy or locked rotor occurs on the motor.	Reduce load or check motor and mechanical conditions.
		The AC drive power class is small.	Replace a drive of larger power class.
		The control mode is SVC, but motor auto-tuning is not performed.	Set motor parameters according to the motor nameplate and perform motor auto-tuning.
		The V/F control mode is used.	Reduce the setting of F3-01 (Torque boost) by 1.0% gradually or set it to 0 (auto torque boost).
E10.01	Pulse-by-pulse current limit fault	The load is too heavy or locked rotor occurs on the motor.	Reduce load or check motor and mechanical conditions.
		The AC drive power class is small.	Replace a drive of larger power class.
E11.00	Motor overload	F9-01 (Motor overload protection gain) is set improperly.	Set F9-01 properly.
		The load is too heavy or locked rotor occurs on the motor.	Reduce load or check motor and mechanical conditions.
E12.01	Input voltage fault	R phase is lost.	Check whether input phase loss occurs.
E12.02		S phase is lost.	Check whether the input cable is broken. Check that DI terminals are properly connected.
E12.03		T phase is lost.	Check the hardware voltage detection circuit.
E12.04		Overvoltage occurs on input phase.	Adjust the voltage to normal range.
E12.05		Voltage imbalance occurs on input phase.	Check whether input phase loss occurs. Check the hardware voltage detection circuit.
E13.00	Output phase loss	The motor is faulty.	Check whether open circuit occurs on the motor.
		The cable connecting the AC drive and the motor is abnormal.	Rectify external faults.
		The AC drive's three-phase outputs are unbalanced when the motor is running.	Check whether the motor three-phase winding is normal.
		The drive board or the IGBT is abnormal.	Contact the agent or Trane.
E14.00	IGBT overheat	The ambient temperature is too high.	Lower the ambient temperature.
		The ventilation is clogged.	Clean the ventilation.
		The cooling fan is damaged.	Replace the fan.
		The thermally sensitive resistor of The IGBT is damaged.	Contact the agent or Trane.
		The IGBT is damaged.	

Fault Code	Fault Name	Cause	Possible Solution
E15.01	External fault	An external fault signal is input through an NO DI.	Confirm that the mechanical condition allows restart (F8-18, Startup protection selection) and reset the operation.
E15.02		An external fault signal is input through an NC DI.	Confirm that the mechanical condition allows restart (F8-18, Startup protection selection) and reset the operation.
E16.01	Communication fault	Modbus communication timeout	Check whether the RS485 cable is correctly connected. Check whether the settings of Fd-04 (Modbus communication timeout) and PLC communication cycle are proper.
E19.02	Motor auto-tuning fault	Auto-tuning of pole position angle of the synchronous motor is faulty.	The motor may be disconnected, or output phase loss may occur.
E19.04			
E19.05		Auto-tuning of initial pole position angle of the synchronous motor is faulty.	Increase the setting of F2-29 (Initial position angle test current for synchronous motor).
E19.06		Stator resistance auto-tuning is faulty.	Check whether the motor is connected. Ensure that F1-03 (Rated motor current) is set according to the motor nameplate.
E19.07			
E19.08			
E19.09			
E19.10		Auto-tuning of instantaneous leakage inductance of the asynchronous motor is faulty.	Check whether the motor is connected, or output phase loss occurs. Ensure that the motor is connected.
E19.11		Inertia auto-tuning is faulty.	Ensure that F1-03 (Rated motor current) is set according to the motor nameplate. Increase the setting of F2-43 (Inertia auto-tuning and dynamic speed reference).
E19.12		Auto-tuning times out.	Check whether the motor is connected, or output phase loss occurs. Ensure that the motor is disconnected from load.
E19.13			
E19.14			
E19.15			
E19.16			
E19.17			
E19.19			
E19.20	Auto-tuning of zero position angle of the no-load synchronous motor times out.	Check the Z feedback signal.	
E19.22	Auto-tuning of pole position of the synchronous motor is faulty.	Ensure that F1-03 (Rated motor current) is set according to the motor nameplate. Decrease the setting of F2-29 (Initial position angle test current for synchronous motor).	
E19.23	Auto-tuning of instantaneous leakage inductance of asynchronous motor is incorrect.	Check whether the AC drive power class is small and replace an AC drive of proper power class based on motor power.	
E19.24	EEPROM read and write fault	EEPROM read and write is abnormal.	For parameters written to EEPROM, check RAM addresses and address mapping If the EEPROM chip is damaged, require the agent or Trane to replace the main control board.
E21.01			
E21.02			
E21.03			
E21.04	Stator resistance is not within the permissible range.	Check whether rated motor voltage and current are incorrectly set and set F1-02 (Rated motor voltage) and F1-03 (Rated motor current) according to the motor nameplate.	
E22.00	Abnormal motor auto-tuning result	Asynchronous motor rotor resistance is not within the permissible range.	Check that auto-tuning is performed after the motor stops.
E22.01			
E22.02		No-load current and mutual inductive reactance of the asynchronous motor are not within the permissible range. If such an alarm is generated, the AC drive calculates no-load current and mutual inductive reactance based on known parameters. The calculated values may be different from optimal values.	Set motor parameters in group F1 according to the motor nameplate. Before auto-tuning, ensure that the motor has no load.



Fault Code	Fault Name	Cause	Possible Solution
E22.03	Abnormal motor auto-tuning result	Synchronous motor back EMF is not within the permissible range after auto-tuning.	Ensure that F1-02 (Rated motor voltage) is set according to the motor nameplate. Before auto-tuning, ensure that the motor has no load.
E22.04		Inertia auto-tuning is faulty.	Ensure that F1-03 (Rated motor current) is set according to the motor nameplate.
E23.00	Short circuit to ground	The motor is short circuited to the ground.	Replace the faulty cable or motor.
E24.00	Motor phase-to-phase short circuit	Phase-to-phase short circuit occurs on the motor.	Check whether two-phase short circuit occurs in three-phase (U, V, W) output.
E26.00	Accumulative running time reached	Accumulative running time reaches the setting value.	Clear the record through parameter initialization.
E29.00	Accumulative power-on time reached	Accumulative power-on time reaches the setting value.	Clear the record through parameter initialization.
E30.00	Load loss	The output current of the AC drive is smaller than F9-64 (Load lost detection level).	Check whether the load is disconnected, or the setting of F9-64 and F9-65 (Load lost detection time) satisfies actual running conditions.
E31.00	PID feedback lost during running	PID feedback is smaller than the setting value of FA-26 (Detection level of PID feedback loss).	Check PID feedback or set FA-26 properly.
E42.00	Excessive speed deviation	Motor auto-tuning is not performed.	Perform motor auto-tuning.
		F9-69 (Detection level of speed error) and F9-70 (Detection time of speed error) are set improperly.	Set F9-69 and F9-70 properly based on actual conditions.
E43.00	Motor over-speed	Encoder parameters are set improperly.	Set encoder parameters properly.
		Motor auto-tuning is not performed.	Perform motor auto-tuning.
		F9-67 (Over-speed detection level) and F9-68 (Over-speed detection time) are set improperly.	Set F9-67 and F9-68 properly based on actual conditions.
E45.00	Motor overheats	Cable connection of the temperature sensor is loose.	Check cable connection of the temperature sensor.
		The motor temperature is too high.	Increase carrier frequency or take other measures to cool the motor.
		The setting of F9-57 (Motor overheat protection threshold) is too small.	Increase the setting of F9-57 (90°C to 100°C for common motors).
E46.01	Synchronous control parameter setting fault	More than two slave types are set.	Check whether the slave option is selected for A8-10, A8-50, and A8-70.
E47.00	STO fault	The STO card is faulty.	Check STO wiring.

## Symptoms and Diagnostics

**Table 21. Symptoms and Diagnostics**

No.	Fault Description	Cause	Possible Solution
1	There is no display at power-on.	The mains voltage is not input or is too low.	Check the power supply.
		The switching power supply on the drive board of the AC drive is faulty.	Check bus voltage.
		The control board or operating panel is faulty. The rectifier module is damaged.	Contact the agent or Trane.

No.	Fault Description	Cause	Possible Solution
2	"HC" is displayed at power-on.	Related components on the control board are damaged. The motor or motor cable is short circuited to ground. The hall sensor is damaged. The mains voltage is too low.	Contact the agent or Trane.
3	"E23.00" is displayed at power-on.	The motor or motor output cable is short circuited to ground. The AC drive is damaged.	Use a megger to measure the insulation resistance of the motor and motor cable. Contact the agent or Trane.
4	The display is normal at power-on. But after running, "HC" is displayed, and the AC drive stops immediately.	The cooling fan is damaged or locked rotor occurs. Short circuit exists in wiring of control terminals.	Replace the fan. Eliminate short circuit faults in control circuit wiring.
5	E14.00 (IGBT overheat) is detected frequently.	The setting of carrier frequency is too high. The cooling fan is damaged, or ventilation is clogged. Components inside the AC drive are damaged (thermistor or others).	Reduce F0-15 (Carrier frequency). Replace the fan or clean the ventilation. Contact the agent or Trane.
6	The motor does not rotate after the AC drive runs.	The motor or motor cable is faulty. Motor parameters are set improperly on the AC drive.	Check that wiring between the AC drive and motor is normal. Restore the factory parameters and reset the following parameters properly: ◆ Motor ratings, such as rated motor frequency and rated motor speed ◆ F0-01 (Motor 1 control mode) and F0-02 (Command source selection) ◆ F3-01 (Torque boost) in V/F control under heavy-load start.
7	DI terminals are disabled.	The drive board is faulty. Related parameters are set improperly. External signals are incorrect. The jumper across OP and +24 V is loose. The control board is faulty.	Contact the agent or Trane. Check and set parameters in group F4 again. Re-connect external signal cables. Re-confirm the jumper bar across OP and +24 V. Contact the agent or Trane.
8	The AC drive detects overcurrent and overvoltage frequently.	Motor parameters are set improperly. Acceleration/Deceleration time is set improperly. Load fluctuates.	Set motor parameters or perform motor auto-tuning again. Set proper acceleration/deceleration time. Contact the agent or Trane.
9	The braking torque is insufficient when the motor is decelerating or decelerates to stop.	Voltage limit is enabled.	If a braking resistance is configured, set F3-23 (V/F voltage limit selection) to 0 (Disabled) to disable voltage limit.

## Function Code

The symbols in the parameter table are described as follows:

☆ : It is possible to modify the parameter with the AC drive in the Stop and in the Run status.

★ : It is not possible to modify the parameter with the AC drive in the Run status.

● : The parameter is the actual measured value and cannot be modified.

\* : The parameter is a factory parameter and can be set only by the manufacturer.

**Table 22. Parameter Table**

Para. No.	Para. Name	Setting Range	Default	Property
<b>Group F0: Standard Parameters</b>				
F0-00	G/P type display	1: G type (constant-torque load model)	Model dependent	●
F0-01	Motor 1 control mode	0: Sensorless vector control (SVC) 1: Reserved 2: Voltage/Frequency (V/F) control (not available for synchronous motor)	0	★
F0-02	Command source selection	0: External Operating panel (keypad & LED display) or commissioning software 1: Terminal I/O control 2: Serial comms.	0	★

Para. No.	Para. Name	Setting Range	Default	Property
<b>Group F0: Standard Parameters</b>				
F0-03	Main frequency reference setting channel selection	0: Digital setting F0-08 (pressing UP or DOWN can revise F0-08 easily, but the revised value would be cleared after power off) 1: Digital setting F0-08 (pressing UP or DOWN can change F0-08 easily, and the revised value won't be cleared even after power off) 2: AI1 3: AI2 4: AI3 5: Pulse setting (DI5) 6: Multi-reference setting 7: Simple PLC 8: PID 9: Communication setting 10: Reserved	0	★
F0-04	Auxiliary frequency reference setting channel selection	Same as F0-03	0	★
F0-05	Base value of range of auxiliary frequency reference for main and auxiliary superposition	0: Relative to maximum frequency 1: Relative to main frequency reference	0	☆
F0-06	Range of auxiliary frequency reference for main and auxiliary superposition	0% to 150%	100%	☆
F0-07	Final frequency reference setting selection	Ones position: Frequency reference selection 0: Main frequency reference 1: Main and auxiliary calculation (based on tens position) 2: Switchover between main and auxiliary 3: Switchover between main and "main & auxiliary calculation" 4: Switchover between auxiliary and "main & auxiliary calculation" Tens position: Main and auxiliary calculation formula 0: Main + auxiliary 1: Main - auxiliary 2: Max. (main, auxiliary) 3: Min. (main, auxiliary) 4: Main x auxiliary	0	☆
F0-08	Preset frequency	0.00 Hz to max. frequency (F0-10)	50.00 Hz	☆
F0-09	Running direction	0: Run in the same direction 1: Run in opposite direction	0	☆
F0-10	Max. frequency	50.00 to 600.00 Hz	50.00 Hz	★
F0-11	Setting channel of frequency reference upper limit	0: Set by F0-12 1: AI1 2: AI2 3: AI3 4: Reserved 5: Communication setting 6: Multi-reference	0	★
F0-12	Frequency reference upper limit	Frequency lower limit (F0-14) to max. frequency (F0-10)	50.00 Hz	☆
F0-13	Frequency reference upper limit offset	0.00 Hz to max. frequency (F0-10)	0.00 Hz	☆
F0-14	Frequency reference lower limit	0.00 Hz to frequency upper limit (F0-12)	0.00 Hz	☆
F0-15	Carrier frequency	2 to 8.0 kHz	Model dependent	☆
F0-16	Carrier frequency adjusted with temperature	0: Disabled 1: Enabled	1	☆
F0-17	Acceleration time 1	0.00s~650.00s (F0-19=2) 0.0s~6500.0s (F0-19=1) 0s~65000s (F0-19=0)	20.0s	☆
F0-18	Deceleration time 1	0.00s~650.00s (F0-19=2) 0.0s~6500.0s (F0-19=1) 0s~65000s (F0-19=0)	20.0s	☆
F0-19	Acceleration/ Deceleration time unit	0: 1s 1: 0.1s 2: 0.01s		★
F0-21	Frequency offset of auxiliary frequency setting channel for main and auxiliary calculation	0.00 Hz to max. frequency (F0-10)	0.00 Hz	☆

Para. No.	Para. Name	Setting Range	Default	Property
<b>Group F0: Standard Parameters</b>				
F0-22	Frequency reference resolution	1: 0.1 Hz 2: 0.01 Hz	2	★
F0-23	Retentive of digital setting frequency upon stop	0: Non-retentive 1: Retentive	0	☆
F0-25	Acceleration/Deceleration time base frequency	0: Maximum frequency (F0-10) 1: Frequency reference 2: 100 Hz	0	★
F0-26	Base frequency for UP/DOWN modification during running	0: Running frequency 1: Frequency reference	0	★
F0-27	Main frequency coefficient	0.00% to 100.00%	10.00%	☆
F0-28	Auxiliary frequency coefficient	0.00% to 100.00%	10.00%	☆

Para. No.	Para. Name	Setting Range	Default	Property
<b>Group F1: Motor 1 Parameters</b>				
F1-00	Motor type selection	0: Common asynchronous motor 1: Variable frequency asynchronous motor 2: Synchronous motor	0	★
F1-01	Rated motor power	0.1 to 1000.0 kW	Model dependent	★
F1-02	Rated motor voltage	1 to 2000 V	Model dependent	★
F1-03	Rated motor current	0.01 to 655.35 A (AC drive power ≤ 55 kW) 0.1 to 6553.5 A (AC drive power > 55 kW)	Model dependent	★
F1-04	Rated motor frequency	0.01 Hz to max. frequency (F0-10)	Model dependent	★
F1-05	Rated motor speed	1 to 65535 RPM	Model dependent	★
F1-06	Asynchronous/ Synchronous motor stator resistance	0.001 to 65.535 Ω (AC drive power ≤ 55 kW) 0.0001 to 6.5535 Ω (AC drive power > 55 kW)	Auto-tuning dependent	★
F1-07	Asynchronous motor rotor resistance	0.001 to 65.535 Ω (AC drive power ≤ 55 kW) 0.0001 to 6.5535 Ω (AC drive power > 55 kW)	Auto-tuning dependent	★
F1-08	Asynchronous motor leakage inductive reactance	0.01 to 655.35 mH (AC drive power ≤ 55 kW) 0.001 to 65.535 mH (AC drive power > 55 kW)	Auto-tuning dependent	★
F1-09	Asynchronous motor mutual inductive reactance	0.1 to 6553.5 mH (AC drive power ≤ 55kW) 0.01 to 655.35 mH (AC drive power > 55 kW)	Auto-tuning dependent	★
F1-10	Asynchronous motor no-load current	0.01 A to F1-03 (AC drive power ≤ 55 kW) 0.1 A to F1-03 (AC drive power > 55 kW)	Auto-tuning dependent	★
F1-11	Asynchronous motor core saturation coefficient 1	50.0% to 100.0%	86.00%	☆
F1-12	Asynchronous motor core saturation coefficient 2	100.0% to 150.0%	130.00%	☆
F1-13	Asynchronous motor core saturation coefficient 3	100.0% to 170.0%	140.00%	☆
F1-14	Asynchronous motor core saturation coefficient 4	100.0% to 180.0%	150.00%	☆
F1-17	Synchronous motor D-axis inductor	0.01 to 655.35 mH (AC drive power ≤ 55 kW) 0.001 to 65.535 mH (AC drive power > 55 kW)	Auto-tuning dependent	★
F1-18	Synchronous motor Q-axis inductor	0.01 to 655.35 mH (AC drive power ≤ 55 kW) 0.001 to 65.535 mH (AC drive power > 55 kW)	Auto-tuning dependent	★
F1-19	Synchronous motor back EMF	0.1 to 6553.5 V	Auto-tuning dependent	★
F1-23	Frictional moment	0.00% to 100.00%	0.00%	★
F1-26	Auto-tuning direction (inertia auto-tuning and synchronous motor)	0, 1	1	★

Para. No.	Para. Name	Setting Range	Default	Property
<b>Group F1: Motor 1 Parameters</b>				
F1-37	Auto-tuning selection	0: No auto-tuning 1: Asynchronous motor static auto-tuning 2: Asynchronous motor no-load auto-tuning 3: Asynchronous motor static complete auto-tuning 11: Synchronous motor no-load partial auto-tuning (back EMF is not auto-tuned) 12: Synchronous motor dynamic no-load auto-tuning 13: Synchronous motor static auto-tuning	0	★

Para. No.	Para. Name	Setting Range	Default	Property
<b>Group F4: Input Terminals</b>				
F4-00	DI1 function selection	0: No function 1: Forward RUN (FWD) 2: Reverse RUN (REV) 3: Three-wire control 4: Forward JOG (FJOG) 5: Reverse JOG (RJOG) 6: Terminal UP 7: Terminal DOWN 8: Coast to stop 9: Fault reset (RESET) 10: RUN pause	0	★
F4-01	DI2 function selection	11: External fault normally open (NO) input 12: Multi-reference terminal 1 13: Multi-reference terminal 2 14: Multi-reference terminal 3 15: Multi-reference terminal 4 16: Terminal 1 for acceleration/deceleration time selection 17: Terminal 2 for acceleration/deceleration time selection	4	★
F4-02	DI3 function selection	18: Frequency source switchover 19: UP and DOWN setting clear (terminal, keypad) 20: Command source switchover terminal 21: Acceleration/Deceleration prohibited 22: PID pause 23: PLC status reset 24: Swing pause 25: Counter input (DIO1) 26: Counter reset	9	★
F4-03	DI4 function selection	27: Length count input (DIO1) 28: Length reset 29: Torque control prohibited 31: Reserved 32: Immediate DC injection braking 33: External fault normally closed (NC) input	12	★
F4-04	DI5 function selection	34: Frequency modification forbidden 35: PID action direction reverse 36: External STOP terminal 1 37: Command source switchover terminal 2 38: PID integral disabled	13	★

F4-05	DI6 function selection	39: Switchover between main frequency source X and preset frequency 40: Switchover between auxiliary frequency source Y and preset frequency 41: Reserved 42: Position lock selection 43: PID parameter switchover 44: User-defined fault 1 45: User-defined fault 2 46: Speed control/Torque control switchover 47: Emergency stop 48: External STOP terminal 2 49: Deceleration DC injection braking 50: Clear the current running time 51: Two-wire/Three-wire switchover 52-60: Reserved	0	★
F4-06	DI7 function selection		0	★
F4-10	DI filter time		0.010s	☆
F4-11	Terminal I/O control mode	0: Two-wire control mode 1 1: Two-wire control mode 2 2: Three-wire control mode 1 3: Three-wire control mode 2	0	★
F4-12	Terminal UP/DOWN rate	0.001 to 65.535 Hz/s	1.000 Hz/s	☆
F4-13	AI curve 1 min. input	0.00 V to F4-15	0.00 V	☆
F4-14	Corresponding percentage of AI curve 1 min. input	-100.0% to 100.0%	-100.0%	☆
F4-15	AI curve 1 max. input	F4-13 to 10.00 V	10.00 V	☆
F4-16	Corresponding percentage of AI curve 1 max. input	-100.0% to 100.0%	100.0%	☆
F4-17	AI1 filter time	0.00s to 10.00s	0.10s	☆
F4-18	AI curve 2 min. input	0.00 V to F4-20	0.00 V	☆
F4-19	Corresponding percentage of AI curve 2 min. input	-100.0% to 100.0%	0.0%	☆
F4-20	AI curve 2 max. input	F4-18 to 10.00 V	10.00 V	☆
F4-21	Corresponding percentage of AI curve 2 max. input	-100.0% to 100.0%	100.0%	☆
F4-22	AI2 filter time	0.00s to 10.00s	0.10s	☆
F4-23	AI curve 3 min. input	0.00 V to F4-25	0.00 V	☆
F4-24	Corresponding percentage of AI curve 3 min. input	-100.0% to 100.0%	0.0%	☆
F4-25	AI curve 3 max. input	F4-23 to 10.00 V	10.00 V	☆
F4-26	Corresponding percentage of AI curve 3 max. input	-100.0% to 100.0%	100.0%	☆
F4-28	Pulse min. input	0.00 kHz to F4-30	0.00 kHz	☆
F4-29	Corresponding percentage of pulse min. input	-100.0% to 100.0%	0.0%	☆
F4-30	Pulse max. input	F4-28 to 100.00 kHz	50.00 kHz	☆
F4-31	Corresponding percentage of pulse max. input	-100.0% to 100.0%	100.0%	☆
F4-32	Pulse filter time	0.00s to 10.00s	0.10s	☆
F4-33	AI curve selection	Ones position: AI1 curve selection 1: Curve 1 (2 points, see F4-13 to F4-16) 2: Curve 2 (2 points, see F4-18 to F4-21) 3: Curve 3 (2 points, see F4-23 to F4-26) 4: Curve 4 (4 points, see A6-00 to A6-07) 5: Curve 5 (4 points, see A6-08 to A6-15) Tens position: AI2 curve selection, same as above Hundreds position: AI3 curve selection, same as above	321	☆
F4-34	Setting selection when AI less than min. input	Ones position: AI1 0: Corresponding percentage of min. input 1: 0.0% Tens position: AI2 Hundreds position: AI3, same as above	0	☆
F4-35	DI1 delay	0.0s to 3600.0s	0.0s	☆
F4-36	DI2 delay	0.0s to 3600.0s	0.0s	☆
F4-37	DI3 delay	0.0s to 3600.0s	0.0s	☆

Para. No.	Para. Name	Setting Range	Default	Property
<b>Group F4: Input Terminals</b>				
F4-38	DI active mode selection 1	0: High level active 1: Low level active Ones position: DI1 active mode Tens position: DI2 active mode Hundreds position: DI3 active mode Thousands position: DI4 active mode Ten thousands position: DI5 active mode	0	★
F4-39	selection 2	0: High level active 1: Low level active Ones position: DI6 active mode Tens position: DI7 active mode Hundreds position: Reserved Thousands position: Reserved Ten thousands position: Reserved	0	★
<b>Group F5: Output Terminals</b>				
F5-00	Reserved		0	☆
F5-01	Relay 3 function selection	0: No output 1: AC drive running 2: Fault output 1 (having output after AC drive stops at occurrence of coast to stop fault and decelerate to stop fault) 3: Frequency-level detection FDT1 output 4: Frequency reached 5: Zero-speed running (no output at stop) 6: Motor overload pre-warning 7: AC drive overload pre-warning	0	☆
F5-02	Relay 1 function selection	8: Set count value reached 9: Designated count value reached 10: Length reached 11: PLC cycle completed 12: Accumulative running time reached 13: Frequency limited 14: Torque limited 15: Ready for RUN 16: AI1 > AI2 17: Frequency upper limit reached 18: Frequency lower limit reached (RUN related)	2	☆
F5-03	Relay 2 function selection	19: Undervoltage status output 20: Communication setting 23: Zero-speed running 2 (having output at stop) 24: Accumulative power-on time reached 25: Frequency level detection FDT2 output 26: Frequency 1 reached 27: Frequency 2 reached 28: Current 1 reached 29: Current 2 reached 30: Timing duration reached 31: AI1 input limit exceeded 32: Load lost		
F5-04	DO1 function selection	33: Reverse running 34: Zero current status 35: IGBT temperature reached 36: Software current limit exceeded 37: Frequency lower limit reached (having output at stop) 38: Alarm output (direct)	0	☆

			output at fault or alarm) 39: Motor overheat warning 40: Current running time reached 41: Fault output 2 (having output after AC drive stops at occurrence of coast to stop fault and decelerate to stop fault; no output at undervoltage) 43: Position lock successful (offset pulses of Position lock less than the value of F6-25)		
F5-05	DO2 function selection			0	☆
F5-06	Reserved		0: Running frequency 1: Set frequency 2: Output current 3: Output torque (100.0% corresponds to twice rated motor torque) 4: Output power 5: Output voltage (100.0% corresponds to 1.2 times rated AC drive voltage) 6: Pulse reference (100.0% corresponds to 50.0 kHz)	0	☆
F5-07	AO1 function selection		7: AI1 8: AI2 9: AI3 10: Length 11: Count value 12: Communication setting 13: Motor rotational speed 14: Output current (100.0% corresponds to 1000.0 A)	0	☆
F5-08	AO2 function selection		15: Output voltage (100.0% corresponds to 1000.0 V) 16: Output torque (directional; 100.0% corresponds to twice rated motor torque)	0	☆
F5-09	Reserved		0.01 to 100.00 kHz	50.00 kHz	☆
F5-10	AO1 zero offset coefficient		-100.0% to 100.0%	0.0%	☆
F5-11	AO1 gain		-10.00 to 10.00	1.00	☆
F5-12	AO2 zero offset coefficient		-100.0% to 100.0%	0.0%	☆
F5-13	AO2 gain		-10.00 to 10.00	1.00	☆
F5-17	Relay 3 output delay		0.0s to 3600.0s	0.0s	☆
F5-18	Relay 1 output delay		0.0s to 3600.0s	0.0s	☆
F5-20	Relay 2 output delay		0.0s to 3600.0s	0.0s	☆
F5-22	DO active mode selection		0: Positive logic active 1: Negative logic active Ones position: Relay 3 active mode Tens position: Relay 1 active mode Hundreds position: Relay 2 active mode Thousands position: DO1 active mode Ten thousands position: DO2 active mode	0	☆

Para. No.	Para. Name	Setting Range	Default	Property
<b>Group Fd: Communication</b>				
Fd-00	Modbus baud rate	0: 300 bps 1: 600 bps 2: 1200 bps 3: 2400 bps 4: 4800 bps 5: 9600 bps 6: 19200 bps 7: 38400 bps 8: 57600 bps 9: 115200 bps	5	☆
Fd-01	Modbus data format	0: No check <8,N,2> 1: Even parity check <8,E,1> 2: Odd parity check <8,O,1> 3: <8,N,1>	0	☆
Fd-02	Modbus local address	1 to 247 0: Broadcast address	1	☆
Fd-03	Modbus response delay	0 to 20 ms	2	☆
Fd-04	Modbus communication timeout	0.1s to 60.0s 0.0: Disabled	0	☆
Fd-06	Auto reset of communication fault	0: Disabled 1: Enabled	1	☆



Para. No.	Para. Name	Setting Range	Default	Property
<b>Group A4: Screw Machine Parameters</b>				
A4-00	Power calculation method selection	0: AC 1: DC	1	☆
A4-01	DC bus current correction coefficient	0% to 500.0%	100.00%	☆
A4-02	Current delay compensation selection	0: Disabled 1: Enabled	1	☆
A4-03	Over-modulation function selection	0: Disabled 1: Enabled	0	☆
A4-04	Power correction coefficient	50.0% to 200.0%	100	☆
A4-05	AC drive power at stop	0.1 to 100.0 kW	1	★
A4-06	AC drive load loss	0.0 to 10.0	0.3	★
A4-07	AC drive input voltage correction coefficient	0 to 200.0	100	☆
A4-08	Energy saving control selection	0, 1	0	★
A4-09 to A4-19	Reserved			
A4-20	DO3 function selection	Same as F5-04	0	☆
A4-21	DO4 function selection	Same as F5-04	4	☆
A4-22	AO3 function selection	Same as F5-07	0	☆
A4-23	AO3 zero offset coefficient	-100.0% to 100.0%	0.0%	☆
A4-24	AO3 gain	-10.00 to 10.00	1.00	☆



# EC Declaration of Conformity

For the following equipment-

Product: Air-Cooled Screw Heat Pump  
 Type Designation/Trademark: RTX-C-XE series  
 Manufacturers Name: Trane Air Conditioning Systems (China) Co., Ltd.  
 Manufacturers Address: No. 88 East Suzhou Road, Taicang, 215400 Jiangsu, P.R. China

Refer to in this declaration conforms to the following directive(s)/standards:

**Machinery Directive 2006/42/EC**

EN ISO 12100:2010, EN ISO 13857:2008, EN 60204-1:2006+A1+AC, EN 378-1:2016,  
EN 378-2:2016

**EMC Directive 2014/30/EU**

EN 61000-6-2:2005, EN 61000-6-4:2007+A1:2011

The company named above will keep on file for review the following technical documentation:

- Operating and maintenance instructions
- Technical drawings
- Description of measures designed to ensure conformity
- Other technical documentation ,e.g., quality assurance measures for design and production

Name and address of the person (established in the Community) complied the technical files:

**SOCIETE Trane 1 rue des Amériques F 88190 GOLBEY**

Responsible for making this declaration is the:

Manufacturer  Authorized representative established within the EU

Authorized representative established within the EU (if applicable):

Company Name : .....

Company Address : .....

Person responsible for making this declaration

Name, Surname : Wendy Wen

Position/Title : Quality Manager

**Taicang** **Mar.13.2023** \_\_\_\_\_

(place) (date) (company stamp and legal signature)



Trane - by Trane Technologies (NYSE:TT), a global climate innovator - creates comfortable, energy efficient indoor environments for commercial and residential applications. For more information, please visit [trane.com](http://trane.com) or [tranetechnologies.com](http://tranetechnologies.com).

Trane has a policy of continuous product and product data improvement and reserves the right to change design and specifications without notice. We are committed to using environmentally conscious print practices.

RTXC-SVX003D-EN Jul. 2023

Supersedes RTXC-SVX003C-EN

©2020 Trane

Confidential and proprietary Trane information