



RTAF SE/HE/XE/HSS/HSE/XSE/XSS

R134a, R513A, R1234ze

Air-cooled

Helical-rotary chillers

300 - 1900 kW

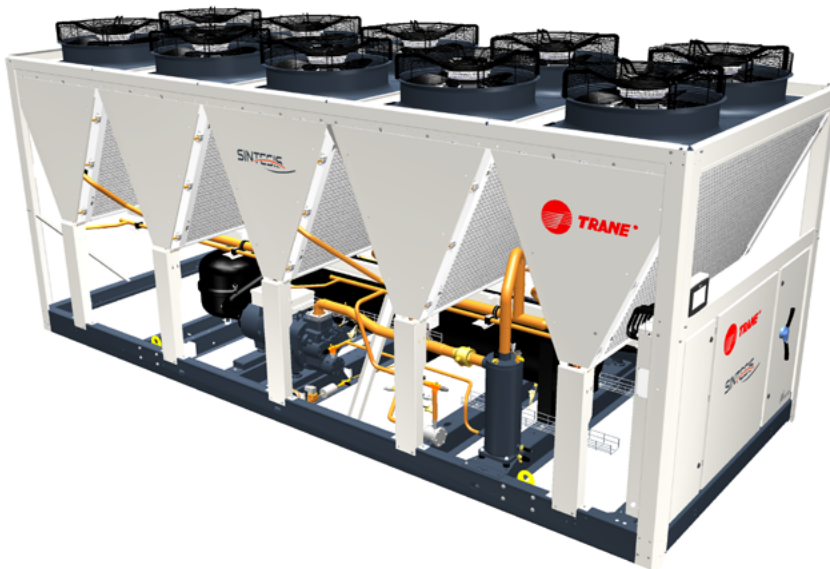

EcoWiseTM

Sintesis chillers are part of the Trane Technologies EcoWise™ portfolio of products that are designed to lower their environmental impact with next-generation, low global warming potential (GWP) refrigerants and high efficiency operation.

SINTECIS

July 2024

RLC-SVX19K-GB

TRANE
TECHNOLOGIES



Table of Contents

Introduction	4
Pre-Installation.....	5
Unit Model Number Description	7
General Data	9
General Data RTAF 090-205 Standard Efficiency- Standard and Low Noise (SN&LN)- R134a- R513A.....	9
General Data RTAF 090-185 Standard Efficiency- Standard and Low Noise (SN&LN)- R1234 ze	11
General Data RTAF 90-205 Standard Efficiency- Extra Low Noise (XLN)- R134a- R513A.....	13
General Data RTAF 090-185 Standard Efficiency- Extra Low Noise (XLN)- R1234 ze	15
General Data RTAF 090-205 Standard Efficiency- AC Extra Low Noise- R134a- R513A	17
General Data RTAF 090-185 Standard Efficiency- AC Extra Low Noise- R1234 ze	19
General Data RTAF 090-205 High Efficiency- Standard and Low Noise- R134a- R513A	21
General Data RTAF 090-185 High Efficiency- Standard and Low Noise- R1234 ze	23
General Data RTAF 090-205 High Efficiency- AC Extra Low Noise- R134a- R513A	25
General Data RTAF 090-185 High Efficiency- AC Extra Low Noise- R1234 ze	27
General Data RTAF 090-205 Extra Efficiency- Standard and Low Noise- R134a- R513A.....	29
General Data RTAF 090-185 Extra Efficiency- Standard and Low Noise- R1234 ze	31
General Data RTAF 090-245 Extra Efficiency- Extra Low Noise- R134a- R513A.....	33
General Data RTAF 090-185 Extra Efficiency- Extra Low Noise- R1234 ze.....	35
General data RTAF 090-245 High Seasonal Efficiency- Standard and Low Noise- R134a- R513A	37
General data RTAF 090-225 High Seasonal Efficiency- Standard and Low Noise- R1234 ze	39
General data RTAF 090-245 High Seasonal Efficiency- Extra Low Noise- R134a- R513A	41
General data RTAF 090-225 High Seasonal Efficiency- Extra Low Noise- R1234 ze	43
General Data RTAF 090-245 High Seasonal Efficiency Short- Standard and Low Noise- R134a- R513A.....	45
General data RTAF 090 225 High Seasonal Efficiency Short- Standard and Low noise- R1234ze.....	47
General Data RTAF 090-245 High Seasonal Efficiency Short- Extra Low Noise- R134a- R513A.....	49
General data RTAF 090-225 High Seasonal Efficiency Short- Extra Low Noise- R1234 ze	51
General Data RTAF 250-450 Standard Efficiency- Standard and low Noise- R134a- R513A.....	53
General Data RTAF 210-340 Standard Efficiency- Standard and low Noise- R1234 ze.....	55
General Data RTAF 250-450 standard efficiency Extra Low Noise- R134a- R513A	57
General Data RTAF 210-340 standard efficiency Extra Low Noise- R1234 ze	59
General Data RTAF 250-450 Standard Efficiency- AC Extra Low Noise- R134a- R513A	61
General Data RTAF 210-340 Standard Efficiency- AC Extra Low Noise- R1234 ze	63
General Data RTAF 250-450 High Efficiency- Standard and Low Noise- R134a- R513A	65
General Data RTAF 210-340 High Efficiency- Standard and Low Noise- R1234 ze	67
General Data RTAF 250-450 High Efficiency- AC Extra Low Noise- R134a- R513A.....	69
General Data RTAF 210-340 High Efficiency- AC Extra Low Noise- R1234 ze.....	71
General Data RTAF 250-450 Extra Efficiency- Standard and Low Noise- R134a- R513A.....	73
General Data RTAF 210-340 Extra Efficiency- Standard and Low Noise- R1234 ze.....	75
General Data RTAF 250-450 Extra Efficiency- Extra Low Noise- R134a- R513A.....	77
General Data RTAF 210-340 Extra Efficiency- Extra Low Noise- R1234 ze.....	79
General Data RTAF 250-410 High Seasonal Efficiency Short- Standard and Low Noise- R134a- R513A.....	81
General Data RTAF 210-405 High Seasonal Efficiency Short- Standard and Low Noise- R1234 ze.....	83
General Data RTAF 250-410 High Seasonal Efficiency Short- Extra Low Noise- R134a- R513A.....	85
General Data RTAF 210-405 High Seasonal Efficiency Short- Extra Low Noise- R1234 ze.....	87
General Data RTAF 250-550 High Seasonal Efficiency- Standard and Low Noise- R134a- R513A.....	89
General Data RTAF 210-470 High Seasonal Efficiency- Standard and Low Noise- R1234 ze.....	91
General Data RTAF 250-550 High Seasonal Efficiency- Extra Low Noise- R134a- R513A.....	93
General Data RTAF 210-470 High Seasonal Efficiency- Extra Low Noise- R1234 ze	95
General data RTAF 100-330 Extra Seasonal Efficiency- Standard and Low Noise- R134a.....	97
General data RTAF 100-330 Extra Seasonal Efficiency- Extra Low Noise- R134a	99
General data RTAF 100-330 Extra Seasonal Efficiency- Whisper Low Noise- R134a	101
General data RTAF 100-330 Extra Seasonal Short- Standard and Low Noise- R134a.....	103
General data RTAF 100-330 Extra Seasonal Short- Standard and Low Noise Low Ambient- R134a	105
General data RTAF 100-330 Extra Seasonal Short- Extra Low Noise- R134a	107

Table of Contents

General data RTAF 100-330 Extra Seasonal Short-Whisper Low Noise- R134a	109
General data RTAF 100-330 Extra Seasonal Short – AC Extra Low Noise- R134a	111
General data RTAF 100-330 Extra Seasonal Short – AC Whisper Low Noise- R134a	113
Installation Requirements	115
Chilled Water Piping Recommendations	118
Evaporator Piping	119
Drainage	120
Evaporator Waterside	122
Optional Integrated Pump Package	126
Partial Heat Recovery	135
Total Heat Recovery	138
Optional Free-Cooling	142
Evaporator Waterside	161
General Electrical Recommendations	166
Installer-Supplied Components	168
Operating Principles	170
Controls	173
Tracer TD7 Operator Interface	173
Operating Map	174
Pre-Start Checkout	175
Unit Start Up Procedures	178
Periodic Maintenance	180
Condenser Coils MCHE Maintenance	186
Integrated Pump Maintenance (Optional with Pump Package)	187
Log Check Sheet	188
Recommended service routine frequencies	189
Additional services	190



Introduction

Foreword

These instructions are given as a guide to good practice in the installation, start-up, operation, and maintenance by the user, of Trane RTAF chillers, manufactured in France. A separate manual is available for the use and maintenance of the unit's control, Tracer™ UC800. They do not contain full service procedures necessary for the continued successful operation of this equipment. The services of a qualified technician should be employed through the medium of a maintenance contract with a reputable service company. Read this manual thoroughly before unit start-up.

Units are assembled, pressure tested, dehydrated, charged and tested in accordance with factory standard before shipment.

Warnings and Cautions

Warnings and Cautions appear at appropriate sections throughout this manual. Your personal safety and the proper operation of this machine require that you follow them carefully. The constructor assumes no liability for installations or servicing performed by unqualified personnel.

WARNING: Indicates a potentially hazardous situation which, if not avoided, could result in death or serious injury.

CAUTION: Indicates a potentially hazardous situation which, if not avoided, may result in minor or moderate injury. It may also be used to alert against unsafe practices or for equipment or property-damage-only accidents.

Safety Recommendations

To avoid death, injury, equipment or property damage, the following recommendations should be observed during maintenance and service visits:

1. The maximum allowable pressures for system leak testing on low and high pressure side are given in the chapter "Installation". Insure to do not exceed test pressure by using appropriate device.
2. Disconnect all power supplies before any servicing on the unit.
3. Service work on the refrigeration system and the electrical system should be carried out only by qualified and experienced personnel.
4. To avoid any risk, it is recommended to place the unit on an area with limited access.

Reception

On arrival, inspect the unit before signing the delivery note. Specify any visible damage on the delivery note, and send a registered letter of protest to the last carrier of the goods within 7 days of delivery.

Notify the local TRANE sales office at the same time. The delivery note must be clearly signed and countersigned by the driver.

Any concealed damage shall be notified by a registered letter of protest to the last carrier of the goods within 7 days of delivery. Notify the local TRANE sales office at the same time.

Important notice: No shipping claims will be accepted by TRANE if the above mentioned procedure is not respected.

For more information, refer to the general sales conditions of your local TRANE sales office.

Note: Unit inspection in France. Delay to send registered letter in case of visible and concealed damage is only 72 hours.

Loose Parts Inventory

Check all the accessories and loose parts that are shipped with the unit against the shipping list. Included in these items will be the water vessel drain plugs, rigging and electrical diagrams, service literature, which are placed inside the control panel and/or starter panel for shipment. If optional elastomeric isolators are ordered with the unit (model number digit 42 =1) they are shipped mounted on the horizontal support frame of the chiller. The isolators' location and distribution weight diagram is placed with the service literature inside the starter/control panel.

Warranty

Warranty is based on the general terms and conditions of the manufacturer. The warranty is void if the equipment is repaired or modified without the written approval of the manufacturer, if the operating limits are exceeded or if the control system or the electrical wiring is modified. Damage due to misuse, lack of maintenance or failure to comply with the manufacturer's instructions or recommendations is not covered by the warranty obligation. If the user does not conform to the rules of this manual, it may entail cancellation of warranty and liabilities by the manufacturer. Startup MUST be performed by Trane, or an authorized agent of Trane, to VALIDATE this WARRANTY. Contractor must provide a two-week startup notification to Trane (or an agent of Trane specifically authorized to perform startup).

Unit Description

The Sintesis RTAF units are helical-rotary type, air-cooled chillers designed for outdoor installation. The refrigerant circuits are factory-piped, leak tested and dehydrated. Every unit is electrically tested for proper control operation before shipment.

Chilled water inlet and outlet openings are covered for shipment. The Sintesis RTAF features Trane's exclusive Adaptive Control™ logic, which monitors the control variables that govern the operation of the chiller unit. Adaptive control logic can adjust capacity variables to avoid chiller shutdown when necessary, and keep producing chilled water. The units feature two independent refrigerant circuits. On the HSE HSS version, 1 compressor per circuit is controlled by a dedicated variable speed Adaptive Frequency Drive. Each refrigerant circuit is provided with filter, sight glass, electronic expansion valve, and charging valves. The shell-and-tube CHIL™ (Compact-High performance-Integrated design-Low charge) evaporator is manufactured in accordance with the Pressure Equipment Directive (PED) code. Each evaporator is fully insulated and equipped with water drain and vent connection.

Units are shipped with full oil charge and can be ordered with either a factory refrigerant charge or optional refrigerant pre-charge.

Pre-Installation

Inspection

When the unit is delivered, verify that it is the correct unit and that it is properly equipped.

Inspect all exterior components for visible damage. Report any apparent damage or material shortage to the carrier and make a "unit damage" notation on the carrier's delivery receipt. Specify the extent and type of damage found and notify the appropriate Trane Sales Office.

Do not proceed with installation of a damaged unit without sales office approval.

Inspection Checklist

To protect against loss due to damage incurred in transit, complete the following checklist upon receipt of the unit.

- Inspect the individual pieces of the shipment before accepting the unit. Check for obvious damage to the unit or packing material.
- Inspect the unit for concealed damage as soon as possible after delivery and before it is stored. Concealed damage must be reported within 10 days after receipt.
- If concealed damage is discovered, stop unpacking the shipment. Do not remove damaged material from the receiving location. Take photos of the damage, if possible. The owner must provide reasonable evidence that the damage did not occur after delivery.
- Notify the carrier's terminal of the damage immediately, by phone and by mail. Request an immediate, joint inspection of the damage with the carrier and the consignee.
- Notify the Trane sales representative and arrange for repair. Do not repair the unit, however, until damage is inspected by the transportation representative.

Storage

Extended storage of the unit prior to the installation requires the following precautions:

Store the unit in a secured area, to avoid intentional damages.

Close the suction, discharge and liquid-line isolation valves.

At least every three months (quarterly), check the pressure in the refrigerant circuits to verify that the refrigerant charge is intact. If it is not, contact a qualified service organization and the appropriate Trane sales office.

Note: *If the unit is stored before servicing near a construction site it is highly recommended to protect micro-channel coils from any concrete dust. Failure to do so may considerably reduce reliability of the unit.*



Pre-Installation

Installation Requirements

A list of the contractor responsibilities typically associated with the unit installation process is provided in Table 1.

Table 1 – Installation requirements

Type	Trane Supplied Trane Installed	Trane Supplied Field Installed	Field Supplied Field Installed
Foundation			<ul style="list-style-type: none"> • Meet foundation requirements
Rigging			<ul style="list-style-type: none"> • Safety chains • Clevis connectors • Lifting beam • Spreader bar
Isolation		<ul style="list-style-type: none"> • Elastomeric isolators (optional) 	<ul style="list-style-type: none"> • Elastomeric isolators (optional)
Electrical	<ul style="list-style-type: none"> • Circuit breakers (optional) • Unit mounted starter 		<ul style="list-style-type: none"> • Circuit breakers (optional) • Electrical connections to unit mounted starter • Wiring sizes per submittal and NEC • Terminal lugs • Ground connection(s) • BAS wiring (optional) • Control voltage wiring • Chilled water pump contactor and wiring • Option relays and wiring
Water piping	<ul style="list-style-type: none"> • Flow switch 		<ul style="list-style-type: none"> • Taps for thermometers and gauges • Thermometers • Water flow pressure gauges • Isolation and balancing valves in water piping • Vents and drain • Waterside pressure relief valves • Water strainer
Insulation	<ul style="list-style-type: none"> • Insulation 		<ul style="list-style-type: none"> • Insulation
Water Piping Connection Components	<ul style="list-style-type: none"> • Grooved pipe 		
Other Materials	<ul style="list-style-type: none"> • R-134a, R-513A or R1234ze refrigerant • Full factory charge or pre-load charge • Dry nitrogen (optional) 		<ul style="list-style-type: none"> • Glycol for Glycol free configuration
<p>"Sintesis Model RTAF Installation Completion Check Sheet and Request for Trane Service"</p>			
Chiller Start-up Commissioning ^(a)	<ul style="list-style-type: none"> • Trane, or an agent of Trane specifically authorized to perform start-up of Trane[®] products 		

^(a) Start-up must be performed by Trane or an agent of Trane specifically authorized to perform start-up and warranty of Trane[®] products. Contractor shall provide Trane (or an agent of Trane specifically authorized to perform start-up) with notice of the scheduled start-up at least two weeks prior to the scheduled start-up.

Unit Model Number Description

Digit 1, 2, 3, 4 – Unit model

RTAF = Air-Cooled Chiller

Digit 5 to 7 - Nominal Tonnage

090 = 90 tons
 100 = 100 tons
 101 = 101 tons Brine application- 2 compressors
 105 = 105 tons
 110 = 110 tons
 120 = 120 tons
 125 = 125 tons
 130 = 130 tons
 140 = 140 tons
 141 = 141 tons Brine application- 3 compressors
 145 = 145 tons
 150 = 150 tons
 155 = 155 tons
 165 = 165 tons
 170 = 170 tons
 175 = 175 tons
 185 = 185 tons
 190 = 190 tons
 191 = 191 tons Brine application- 4 compressors
 200 = 200 tons
 205 = 205 tons
 210 = 210 tons
 225 = 225 tons
 230 = 230 tons
 245 = 245 tons
 250 = 250 tons
 265 = 265 tons
 275 = 275 tons
 280 = 280 tons
 285 = 285 tons
 300 = 300 tons
 305 = 305 tons
 310 = 310 tons
 330 = 330 tons
 340 = 340 tons
 350 = 350 tons
 355 = 355 tons
 370 = 370 tons
 380 = 380 tons
 400 = 400 tons
 405 = 405 tons
 410 = 410 tons
 415 = 415 tons
 450 = 450 tons
 470 = 470 tons
 510 = 510 tons
 550 = 550 tons

Digit 8 – Unit voltage

D = 400V/50Hz/3ph
 4 = 460V/60Hz/3ph
 J = 380V/60Hz/3ph

Digit 9 – Manufacturing Location

E = Europe

Digit 10, 11 – Design sequence

A0 = Factory assigned

Digit 12 - Efficiency

N = Standard Efficiency
 H = High Efficiency
 A = Extra Efficiency
 U = High Seasonal Short (HSS)
 V = High Seasonal Efficiency
 B = Extra Seasonal Efficiency (XSE)
 C = Extra Seasonal Short (XSS)

Digit 13 – Agency listing

C = CE Marking

Digit 14 – Pressure vessel code

2 = PED (Pressure equipment directive)
 D = Australian code

Digit 15 – Acoustic level

X = Standard noise (SN)
 L = Low noise (LN)
 A = AC Extra Low Noise
 Q = Low Noise with Night Noise SetBack (NNSB)
 E = Extra Low Noise (XLN)
 W = Whisper Low noise (WLN)

Digit 16 – Operating map : airside

X = Standard ambient
 L = Low ambient
 H = High ambient

Digit 17 – Relief valve option

L = Single Relief Valve High Pressure side
 D = Dual Relief Valve with 3 way valve High Pressure side

Digit 18 – Water connection

X = Grooved pipe connection
 W = Grooved pipe with coupling and pipe stub

Digit 19 – Operating map water side

N = Comfort cooling (above 4.4°C)
 P = Process cooling (below 4.4°C) (Brine application)
 C = Ice Making (-7°C to 20°C)

Digit 20 – Evaporator Configurations

2 = Standard pass evaporator
 T = Standard Pass Evaporator + Turbulators

Digit 21 – Thermal Insulation

N = Standard
 H = High performance
 X = None

Digit 22 – Condenser Coating

N = Aluminum Micro Channel
 C = E-Coated Micro Channel (Free Cooling excluded)

Digit 23 - Heat Recovery

X = No Heat Recovery
 P = Partial Heat Recovery
 Q = Partial Heat Recovery with on site fan control (PHR +)
 T = Total Heat Recovery (full equipment)
 V = Total Heat Recovery (no piping connection)

Digit 24 – Hydraulic module

X = Pump signal On/Off
 1 = Dual pump standard pressure
 3 = Dual pump high pressure



Unit Model Number Description

Digit 25 - Free Cooling

X = No Free Cooling
F = Total Free-Cooling Direct
G = Partial Free-cooling Direct
H = Total Free Cooling Glycol Free
J = Partial Free Cooling Glycol Free

Digit 26 – Disconnect switch

F = With Fuse
B = With circuit breaker

Digit 27 – Under/Over Voltage

X = None
1 = Included
2 = Included with ground fault protection

Digit 28 – Human Interface language

C = Spanish
D = German
E = English
F = French
H = Dutch
I = Italian
M = Swedish
P = Polish
R = Russian
T = Czech
U = Greek
V = Portuguese
2 = Romanian
6 = Hungarian
8 = Turkish

Digit 29 – Smart com protocol

X = None
B = Bacnet interface
M = Modbus interface
L = LonTalk interface

Digit 30 – Communication customer

X = None
A = External set point & capacity outputs

Digit 31 – Flow switch

X = None
F = Field installed flow switch

Digit 32 – Electrical Panel Protection

X = Enclosure with deadfront protection
1 = Enclosure with IP 20 internal protection

Digit 33 – Master Slave

X = Open for Future Use

Digit 34 – Unit User Interface

L = Standard, Local UI supplied (TD7)

Digit 35 – Energy meter

X = No energy meter
M = Energy meter installed

Digit 36 – Open for future use = X

Digit 37 – Variable Primary Flow

X = None
F = Constant Speed Pump-AFD Adjustment
P = Variable Speed Pump- Constant delta P
T = Variable Speed Pump- Constant delta T

Digit 38 – Open for future use = X

Digit 39 – Open for future use = X

Digit 40 – Power socket

X = None
P = Included (230V- 100W)

Digit 41 – Factory tests

X = No final performances test
B = Visual inspection with customer
E = Performance test w/o customer

Digit 42 – Installation accessory

X = None
1 = Neoprene Isolators
4 = Neoprene pads

Digit 43 – Literature language

B = Bulgarian
C = Spanish
D = German
E = English
F = French
H = Dutch
I = Italian
K = Finnish
L = Danish
M = Swedish
N = Norwegian
P = Polish
R = Russian
T = Czech
U = Greek
V = Portuguese
Z = Slovenian
2 = Romanian
3 = Serbian
4 = Slovak
5 = Croatian
6 = Hungarian
8 = Turkish

Digit 44 – Shipping package

X = Standard protection
A = Containerization package

Digit 45 – Refrigerant

0 = R134a Factory pre-charge
1 = R134a Factory full refrigerant charge
2 = R513A Factory pre-charge
3 = R513A Factory full refrigerant charge
L = Factory Nitrogen Charge for R1234ze unit
M = Factory Nitrogen Charge for R513A unit
N = Factory Nitrogen Charge for R134a unit
Y = R1234ze Factory pre-charge
Z = R1234ze Factory full refrigerant charge

Digit 46 – Oil Cooler (Only applicable to XSE/XSS)

X = No
C = Yes
For SE/HE/XE/HSS/HSE, this digit is always = X

Digit 47 – Expansion valve (Only applicable to XSE/XSS)

L = Large valve
U = Undersized valve (Only for XSE & XSS)
For SE/HE/XE/HSS/HSE, this digit is always = X

Digit 48 – Design special

X = none
S = special



General Data

Table 2a – General Data RTAF 090-245 Standard Efficiency - Standard and Low Noise (SN&LN) - R134a - R513A

		RTAF 090	RTAF 105	RTAF 125	RTAF 140	RTAF 145	RTAF 150	RTAF 155	RTAF 170	RTAF 175	RTAF 185	RTAF 190	RTAF 200	RTAF 205	RTAF 245 (10)	
		SE	SN	LN	SE	SN	LN	SE	SN	LN	SE	SN	LN	SE	SN	LN
Cooling Capacity (1)	(kW)	326	375	440	505	522	542	564	581	615	655	675	707	732	816	
Unit electrical data (2)																
(3) (5)																
Maximum Power input in cooling	(kW)	136.4	157.6	185.8	214	217.7	236.4	240.1	258.8	263.0	285.4	289.1	308.3	312.0	312	
Unit rated amps (Max compr +Fan+Control)	(A)	229	267	317	367	375	402	410	437	449	484	492	523	531	530	
Unit start up amps (Starting Amps of the largest compr+RLA of 2nd compr+RLA of all fans+ control)	(A)	276	331	442	492	500	555	563	590	574	637	645	637	645	644	
Displacement Power Factor (DPF)		0.87	0.86	0.85	0.85	0.84	0.85	0.85	0.86	0.85	0.86	0.85	0.85	0.85	0.85	
Max power cable cross section	(mm ²)	1x240	1x240	1x240	2x300	2x300	2x300	2x300	2x300	2x300	2x300	2x300	2x300	2x300	2x300	
Disconnect switch size	(A)	400	400	500	630	630	630	630	630	630	800	800	800	800	800	
Compressor																
Quantity	#	2	2	2	2	2	2	2	2	2	2	2	2	2	2	
Type		Screw	Screw	Screw	Screw	Screw	Screw	Screw	Screw	Screw	Screw	Screw	Screw	Screw	Screw	
Model (9)		45/45	50/50	70/50	70/70	70/70	85/70	85/70	85/85	100/70	100/85	100/85	100/100	100/100	100/100	
Max Compr Power input Circuit 1/Circuit 2	kW	60/60	71/71	99/71	99/99	99/99	121/99	121/99	121/121	144/99	144/121	144/121	144/144	144/144	144/144	
Max Amps Circuit 1 / Circuit 2 (3) (5)	(A)	97/97	116/116	166/116	166/166	166/166	201/166	201/166	201/201	240/166	240/201	240/201	240/240	240/240	240/240	
Start up Amps Circuit 1 / Circuit 2 (3) (5)	(A)	144/144	180/180	291/180	291/291	291/291	354/291	354/291	354/354	354/291	354/354	354/354	354/354	354/354	354/354	
Motor RPM	(rpm)	3000	3000	3000	3000	3000	3000	3000	3000	3000	3000	3000	3000	3000	3000	
Oil sump heater Circuit 1 / Circuit 2	(W)	150/150	150/150	150/150	150/150	150/150	150/150	150/150	150/151	150/150	150/150	150/150	150/150	150/150	150/150	
Evaporator																
Quantity	#	1	1	1	1	1	1	1	1	1	1	1	1	1	1	
Type		Flooded shell and tube heat exchanger														
Evaporator model		115B	115A	165B	165B	165B	165A	165A	200B	200B	200B	200B	250C	250C	250B	
Evaporator Water Content volume	(l)	51	58	74	74	74	78	78	99	99	99	99	109	109	118	
Antifreeze Heater	(W)	1640	1640	1640	1640	1640	1640	1640	2040	2040	2040	2040	2040	2040	2040	
Two pass evaporator																
Evap. Water Flow rate - Minimum	(l/s)	8.0	9.4	11.6	11.6	11.6	12.4	12.4	12.4	12.4	14.2	14.2	16.2	16.2	17.9	
Evap. Water Flow rate - Maximum (6)	(l/s)	29.6	34.7	43.1	43.1	43.1	46.0	46.0	46.0	46.0	52.6	52.6	60.3	60.3	66.5	
Nominal water connection size (Grooved coupling)	(in) - (DN)	4" - 100	4" - 100	5" - 125	5" - 125	5" - 125	5" - 125	5" - 125	5" - 125	5" - 125	6" - 150	6" - 150	6" - 150	6" - 150	6" - 150	
Two pass evaporator with turbulator																
Evap. Water Flow rate - Minimum (6)	(l/s)	6.6	7.8	9.7	9.7	9.7	10.3	10.3	10.3	10.3	11.8	11.8	13.5	13.5	14.9	
Evap. Water Flow rate - Maximum	(l/s)	26.6	31.2	38.7	38.7	38.7	41.3	41.3	41.3	41.3	47.2	47.2	54.1	54.1	59.7	
Nominal water connection size (Grooved coupling)	(in) - (mm)	4" - 100	4" - 100	5" - 125	5" - 125	5" - 125	5" - 125	5" - 125	5" - 125	5" - 125	6" - 150	6" - 150	6" - 150	6" - 150	6" - 150	
Hydraulic Module Components																
Standard head pressure pump option (Twin pump)																
Available Head Pressure (1)	(kPa)	140	128	142	119	119	177	177	NA	173	154	154	143	143	143	
Max Motor Power input	(kW)	5.5	5.5	7.5	7.5	7.5	11.0	11.0	NA	11.0	11.0	11.0	11.0	11.0	11.0	
Max Amps	(A)	11	11	14	14	14	21	21	NA	21	21	21	21	21	21	
High head pressure pump option (Twin Pump)																
Available Head Pressure (1)	(kPa)	252	239	223	NA	244	NA	235	NA	231	264	264	254	254	254	
Max Motor Power input	(kW)	11.0	11.0	11.0	NA	15.0	NA	15.0	NA	15.0	18.5	18.5	18.5	18.5	18.5	
Max Amps	(A)	21	21	21	NA	28	NA	28	NA	28	35	35	35	35	35	
Expansion Tank Volume	(l)	80	80	80	NA	80	NA	80	NA	80	80	80	80	80	80	



General Data

Table 2a – General Data RTAF 090-245 Standard Efficiency - Standard and Low Noise (SN&LN) - R134a - R513A (continued)

		RTAF 090	RTAF 105	RTAF 125	RTAF 140	RTAF 145	RTAF 150	RTAF 155	RTAF 170	RTAF 175	RTAF 185	RTAF 190	RTAF 200	RTAF 205	RTAF 245 (10)	
		SE	SN	LN	SE	SN	LN	SE	SN	LN	SE	SN	LN	SE	SN	LN
Max User water loop Volume for factory mounted expansion tank (1)	(l)	6000	6000	6000	NA	6000	NA	6000	NA	6000	6000	6000	6000	6000	6000	6000
Max. Water-side Operating Pressure without pump package	(kPa)	1000	1000	1000	NA	1000	NA	1000	NA	1000	1000	1000	1000	1000	1000	1000
Max. Water-side Operating Pressure with pump package	(kPa)	450	450	450	NA	450	NA	450	NA	450	450	450	450	450	450	450
Antifreeze Heater with pump package	(W)	2400	2400	2400	2400	2400	2400	2400	2800	2800	2800	2800	2800	2800	2800	2800
Condenser																
Type		Full aluminum Micro channel heat exchanger														
Quantity	#	4/4	4/4	4/4	4/4	5/5	4/4	5/5	4/4	6/4	5/5	6/6	5/5	6/6	6/6	6/6
Face area per coil	(m ²)	2.4	2.4	2.4	2.4	2.4	2.4	2.4	2.4	2.4	2.4	2.4	2.4	2.4	2.4	2.4
Condenser Fan																
Quantity	#	4/4	4/4	4/4	4/4	5/5	4/4	5/5	5/5	6/4	5/5	6/6	5/5	6/6	6/6	6/6
Diameter	(mm)	800	800	800	800	800	800	800	800	800	800	800	800	800	800	800
Standard / High ambient fan option																
Fan / motor Type		Propeller fan / Fixed speed - AC motor														
Airflow per Fan	(m ³ /h)	20000	20000	20000	20000	20000	20000	20000	20000	20000	20000	20000	20000	20000	20000	20000
Max Power input per Motor	(kW)	1.40	1.40	1.40	1.40	1.40	1.40	1.40	1.40	1.40	1.40	1.40	1.40	1.40	1.40	1.40
Max Amps per Motor	(A)	3.4	3.4	3.4	3.4	3.4	3.4	3.4	3.4	3.4	3.4	3.4	3.4	3.4	3.4	3.4
Motor RPM	(rpm)	932	932	932	932	932	932	932	932	932	932	932	932	932	932	932
Low ambient fan option																
Fan / motor Type		Propeller fan / Variable speed - EC motor														
Airflow per Fan	(m ³ /h)	20000	20000	20000	20000	20000	20000	20000	20000	20000	20000	20000	20000	20000	20000	20000
Max Power input per Motor	(kW)	1.30	1.30	1.30	1.30	1.30	1.30	1.30	1.30	1.30	1.30	1.30	1.30	1.30	1.30	1.30
Max Amps per Motor	(A)	2.3	2.3	2.3	2.3	2.3	2.3	2.3	2.3	2.3	2.3	2.3	2.3	2.3	2.3	2.3
Motor RPM	(rpm)	910	910	910	910	910	910	910	910	910	910	910	910	910	910	910
System data (5)																
Nb of refrigerant circuit	#	2	2	2	2	2	2	2	2	2	2	2	2	2	2	2
Minimum cooling load % (4) (7)	%	30	30	30	30	30	30	30	30	30	30	30	30	30	30	30
R134a/R513A refrigerant charge Circuit 1 / Circuit 2 (8)	(kg)	41/39	40/38	42/38	42/40	45/43	44/38	47/41	54/40	57/43	56/50	59/53	60/56	63/59	63/59	63/59
Oil charge Circuit 1 / Circuit 2	(l)	6/6	6/6	6/6	6/6	6/6	7/6	7/6	7/6	7/6	7/7	7/7	8/8	8/8	8/8	8/8
POE Oil type		OIL0048E or OIL0023E														

- (1) Indicative performance at Evaporator water temperature: 12°C / 7°C- Condenser air temperature 35°C- for detailed performances consult Order Write Up.
- (2) Under 400V/3/50Hz.
- (3) Rated Condition without Pump Package.
- (4) Percent minimum load may be adjusted around 15%-20% according to operating conditions by local sales office.
- (5) Electrical & system data are indicative and subject to change without notice. Please refer to unit nameplate data.
- (6) Not applicable for Glycol application- see tables with Minimum Flow with Glycol.
- (7) Max speed - range is 60% to 100% of max speed.
- (8) Refrigerant charge may vary according to option - for instance +20% for process (digit 19 = p). For real value refer to unit nameplate.
- (9) Data containing information on two circuits shown as follows: ckt1/ckt2.
- (10) Size 245 not available in R513A.

General Data

Table 2b – General Data RTAF 090-185 Standard Efficiency - Standard and Low Noise (SN&LN) - R1234 ze

		RTAF	RTAF	RTAF	RTAF	RTAF	RTAF	RTAF	
		090	100	110	120	130	145	155	185
		SE SN LN	SE SN LN	SE SN LN	SE SN LN	SE SN LN	SE SN LN	SE SN LN	SE SN LN
Cooling Capacity (1)	(kW)	325	357	387	419	450	502	544	602
Unit electrical data (2) (3) (4)									
Maximum Power input in cooling	(kW)	162	176	190	201	212	242	269	273
Unit rated amps (Max compressor+fan+control)	(A)	272	295	318	339	360	409	450	458
Unit start up amps starting Amps of the larges compr+RLA of 2nd compr+RLA of all fans+control)	(A)	370	412	435	467	488	559	600	608
Displacement Power Factor (DPF)		0.87	0.87	0.87	0.88	0.85	0.86	0.87	0.87
Max power cable cross section	mm ²	1*240	1*240	1*240	1*240	1*240	2*300	2*300	2*300
Disconnect switch size	(A)	400	400	500	500	500	630	630	630
Compressor									
Quantity	#	2	2	2	2	2	2	2	2
Type		Screw	Screw	Screw	Screw	Screw	Screw	Screw	Screw
Model (9)		45/45	55/45	55/55	65/55	65/65	78/65	78/78	78/78
Max Compr Power input (Circuit 1 / Circuit 2)	kW	73/73	87/73	87/87	98/87	98/98	125/98	125/125	125/125
Max Amps Circuit1 / Circuit 2 (3) (5)	(A)	119/119	142/119	142/142	163/142	163/163	204/163	204/204	204/204
Start up Amps Circuit1 / Circuit 2 (3)(5)	(A)	217/217	259/217	259/259	291/259	291/291	354/291	354/354	354/354
Motor RPM	(rpm)	3000	3000	3000	3000	3000	3000	3000	3000
Oil sump heater Circuit1 / Circuit 2	(W)				150/150				
Evaporator									
Quantity	#	1	1	1	1	1	1	1	1
Type		Flooded shell and tube heat exchanger							
Evaporator model		115B	115A	115A	165C	165B	200C	200C	200B
Evaporator Water Content volume	(l)	51	58	58	64	74	89	89	99
Antifreeze Heater	(W)	1.640	1.640	1.640	1.640	1.640	1.640	1.640	2.040
Two pass evaporator									
Evap. Water Flow rate - Minimum (6)	(l/s)	8.0	9.4	9.4	11.1	11.6	13.0	13.0	14.2
Evap. Water Flow rate - Maximum	(l/s)	29.6	34.7	34.7	41.2	43.1	48.0	48.0	52.6
Nominal water connection size (Grooved coupling)	(in) - (mm)	4" - 100	4" - 100	4" - 100	5" - 125	5" - 125	6" - 150	6" - 150	6" - 150
Two pass evaporator with turbulator									
Evap. Water Flow rate - Minimum (6)	(l/s)	6.6	7.8	7.8	9.3	9.7	10.8	10.8	11.8
Evap. Water Flow rate - Maximum	(l/s)	26.6	31.2	31.2	37.0	38.7	43.1	43.1	47.2
Nominal water connection size (Grooved coupling)	(in) - (mm)	4" - 100	4" - 100	4" - 100	5" - 125	5" - 125	6" - 150	6" - 150	6" - 150
Hydraulic Module Components									
Standard head pressure pump option (twin pumps)									
Available Head Pressure (1)	(kPa)	129	126	111	107	136	121	160	151
Max. Motor Power	(kW)	5.5	5.5	5.5	5.5	7.5	7.5	11.0	11.0
Max Amps	(A)	11.0	11.0	11.0	11.0	14.4	14.4	20.8	20.8
High head pressure pump option (twin pumps)									
Available Head Pressure (1)	(kPa)	246	243	227	222	212	237	226	218
Max. Motor Power	(kW)	11.0	11.0	11.0	11.0	11.0	15.0	15.0	15.0
Max Amps	(A)	20.8	20.8	20.8	20.8	20.8	28.0	28.0	28.0
Expansion Tank Volume	(l)	80	80	80	80	80	80	80	80
Max User water loop Volume for factory mounted expansion tank (1)	(l)	6000	6000	6000	6000	6000	6000	6000	6000
Max. Water-side Operating Pressure without pump package	(kPa)	1000	1000	1000	1000	1000	1000	1000	1000
Max. Water-side Operating Pressure with pump package	(kPa)	450	450	450	450	450	450	450	450
Antifreeze Heater with pump package	(W)	2400	2400	2400	2400	2400	2400	2400	2800
Condenser									
Type		MCHE							
Quantity	#	4/4	4/4	4/4	4/4	4/4	5/5	5/5	6/6
Face area per coil	(m ²)	2.4	2.4	2.4	2.4	2.4	2.4	2.4	2.4
Condenser Fan (nominal conditions)									
Quantity	#	4/4	4/4	4/4	4/4	4/4	5/5	5/5	6/6
Diameter	(mm)	800	800	800	800	800	800	800	800
Standard / High ambient fan option									
Fan / motor Type		Propeller fan / Fixed speed - AC motor							
Airflow per Fan	(m ³ /h)	20000	20000	20000	20000	20000	20000	20000	20000
Max Power input per Motor	(kW)	1.4	1.4	1.4	1.4	1.4	1.4	1.4	1.4
Max Amps per Motor	(A)	3.4	3.4	3.4	3.4	3.4	3.4	3.4	3.4
Motor RPM	(rpm)	932	932	932	932	932	932	932	932

General Data

Table 2b – General Data RTAF 090-185 Standard Efficiency - Standard and Low Noise (SN&LN) - R1234 ze (continued)

		RTAF 090		RTAF 100		RTAF 110		RTAF 120		RTAF 130		RTAF 145		RTAF 155		RTAF 185	
		SE	SN LN	SE	SN LN	SE	SN LN	SE	SN LN	SE	SN LN	SE	SN LN	SE	SN LN	SE	SN LN
Low ambient fan option																	
Fan / motor Type		Propeller fan / Variable speed - EC motor															
Airflow per Fan	(m ³ /h)	20000	20000	20000	20000	20000	20000	20000	20000	20000	20000	20000	20000	20000	20000	20000	20000
Max Power input per Motor	(kW)	1.4	1.4	1.4	1.4	1.4	1.4	1.4	1.4	1.4	1.4	1.4	1.4	1.4	1.4	1.4	1.4
Max Amps per Motor	(A)	3.4	3.4	3.4	3.4	3.4	3.4	3.4	3.4	3.4	3.4	3.4	3.4	3.4	3.4	3.4	3.4
Motor RPM	(rpm)	932	932	932	932	932	932	932	932	932	932	932	932	932	932	932	932
System data																	
Nb of refrigerant circuit	#	2	2	2	2	2	2	2	2	2	2	2	2	2	2	2	2
Minimum cooling load % (6)	%	30	30	30	30	30	30	30	30	30	30	30	30	30	30	30	30
Refrigerant charge Circuit1 / Circuit 2 (8)	(kg)	41/39	40/38	40/38	41/42	42/40	55/45	55/45	60/46								
Oil charge Circuit1 / Circuit 2	(l)	5/5	5/5	5/5	6/5	6/6	6/6	6/6	6/6	6/6	6/6	6/6	6/6	6/6	6/6	6/6	6/6
POE Oil type (10)		OIL00317 or OIL00315															

(1) Indicative performance at Evaporator water temperature: 12°C / 7°C - Condenser air temperature 35°C- for detailed performances consult Order Write Up.

(2) Under 400V/3/50Hz.

(3) Rated Condition without Pump Package.

(4) Percent minimum load may be adjusted around 15%-20% according to operating conditions by local sales office.

(5) Electrical & system data are indicative and subject to change without notice. Please refer to unit nameplate data.

(6) Not applicable for Glycol application - see tables with Minimum Flow with Glycol.

(7) Max speed - range is 60% to 100% of max speed.

(8) Refrigerant charge may vary according to option - for instance +20% for process (digit 19 = p). For real value refer to unit nameplate.

(9) Data containing information on two circuits shown as follows: ckt1/ckt2.

(10) OIL0066E or OIL0067E may have been used on early orders and there is no restriction to continue to use them but preferable oil is OIL00315 or OIL00317.



General Data

Table 3a – General Data RTAF 90-245 Standard Efficiency - Extra Low Noise (XLN) - R134a - R513A

		RTAF 090	RTAF 105	RTAF 125	RTAF 140	RTAF 145	RTAF 150	RTAF 155	RTAF 170	RTAF 175	RTAF 185	RTAF 190	RTAF 200	RTAF 205	RTAF 245 (10)
		SE XLN	SE XLN	SE XLN	SE XLN	SE XLN	SE XLN	SE XLN	SE XLN	SE XLN	SE XLN	SE XLN	SE XLN	SE XLN	SE XLN
Cooling Capacity (1)	(kW)	326	375	440	505	522	542	564	581	615	655	675	707	732	816
Unit electrical data (2) (3) (5)															
Maximum Power input in cooling	(kW)	137.2	158.4	186.6	215	218.7	237	241.1	260	264.0	286	290	309	313.2	313
Unit rated amps (Max compr +Fan+Control)	(A)	221	259	309	359	365	394	400	429	439	474	480	513	519	518
Unit start up amps (Starting Amps of the largest compr+RLA of 2nd compr+RLA of all fans+ control)	(A)	268	323	434	484	490	547	553	582	564	627	633	627	633	632
Displacement Power Factor (DPF)		0.90	0.89	0.87	0.87	0.87	0.87	0.87	0.88	0.87	0.87	0.87	0.87	0.87	0.87
Max power cable cross section	(mm ²)	1x240	1x240	1x240	2x300	2x300	2x300	2x300	2x300	2x300	2x300	2x300	2x300	2x300	2x300
Disconnect switch size	(A)	400	400	500	630	630	630	630	630	630	800	800	800	800	800
Compressor															
Quantity	#	2	2	2	2	2	2	2	2	2	2	2	2	2	2
Type		Screw	Screw	Screw	Screw	Screw	Screw	Screw	Screw	Screw	Screw	Screw	Screw	Screw	Screw
Model (9)		45/45	50/50	70/50	70/70	70/70	85/70	85/70	85/85	100/70	100/85	100/85	100/100	100/100	100/100
Max Compr Power input	kW	60/60	71/71	99/71	99/98	99/99	121/98	121/99	121/121	144/99	144/120	144/121	144/143	144/144	144/144
Max Amps Circuit 1 / Circuit 2 (3) (5)	(A)	97/97	116/116	166/116	166/165	166/166	201/165	201/166	201/201	240/166	240/200	240/201	240/239	240/240	240/240
Start up Amps Circuit 1 / Circuit 2 (3) (5)	(A)	144/144	180/180	291/180	291/290	291/291	354/290	354/291	354/354	354/291	354/353	354/354	354/353	354/354	354/354
Motor RPM	(rpm)	3000	3000	3000	3000	3000	3000	3000	3000	3000	3000	3000	3000	3000	3000
Oil sump heater Circuit 1 / Circuit 2	(W)	150/150	150/150	150/150	150/150	150/150	150/150	150/150	150/150	150/150	150/150	150/150	150/150	150/150	150/150
Evaporator															
Quantity	#	1	1	1	1	1	1	1	1	1	1	1	1	1	1
Type		Flooded shell and tube heat exchanger													
Evaporator model		115B	115A	165B	165B	165B	165A	165A	200B	200B	200B	200B	250C	250C	250B
Evaporator Water Content volume	(l)	51	58	74	74	74	78	78	99	99	99	99	109	109	118
Antifreeze Heater	(W)	1640	1640	1640	1640	1640	1640	1640	2040	2040	2040	2040	2040	2040	2040
Two pass evaporator															
Evap. Water Flow rate - Minimum	(l/s)	8.0	9.4	11.6	11.6	11.6	12.4	12.4	12.4	12.4	14.2	14.2	16.2	16.2	17.9
Evap. Water Flow rate - Maximum (6)	(l/s)	29.6	34.7	43.1	43.1	43.1	46.0	46.0	46.0	46.0	52.6	52.6	60.3	60.3	66.5
Nominal water connection size (Grooved coupling)	(in) - (DN)	4" - 100	4" - 100	5" - 125	5" - 125	5" - 125	5" - 125	5" - 125	5" - 125	5" - 125	5" - 125	6" - 150	6" - 150	6" - 150	6" - 150
Two pass evaporator with turbulator															
Evap. Water Flow rate - Minimum (6)	(l/s)	6.6	7.8	9.7	9.7	9.7	10.3	10.3	10.3	10.3	11.8	11.8	13.5	13.5	14.9
Evap. Water Flow rate - Maximum	(l/s)	26.6	31.2	38.7	38.7	38.7	41.3	41.3	41.3	41.3	47.2	47.2	54.1	54.1	59.7
Nominal water connection size (Grooved coupling)	(in) - (mm)	4" - 100	4" - 100	5" - 125	5" - 125	5" - 125	5" - 125	5" - 125	5" - 125	5" - 125	5" - 125	6" - 150	6" - 150	6" - 150	6" - 150
Hydraulic Module Components															
Standard head pressure pump option (Twin pump)															
Available Head Pressure (1)	(kPa)	140	128	142	119	119	177	177	NA	173	154	154	143	143	143
Max Motor Power input	(kW)	5.5	5.5	7.5	7.5	7.5	11.0	11.0	NA	11.0	11.0	11.0	11.0	11.0	11.0
Max Amps	(A)	11	11	14	14	14	21	21	NA	21	21	21	21	21	21
High head pressure pump option (Twin Pump)															
Available Head Pressure (1)	(kPa)	252	239	223	NA	244	NA	235	NA	231	264	264	254	254	254
Max Motor Power input	(kW)	11.0	11.0	11.0	NA	15.0	NA	15.0	NA	15.0	18.5	18.5	18.5	18.5	18.5
Max Amps	(A)	21	21	21	NA	28	NA	28	NA	28	35	35	35	35	35
Expansion Tank Volume	(l)	80	80	80	NA	80	NA	80	NA	80	80	80	80	80	80

General Data

Table 3a – General Data RTAF 90-245 Standard Efficiency- Extra Low Noise (XLN) - R134a - R513A (continued)

		RTAF 090	RTAF 105	RTAF 125	RTAF 140	RTAF 145	RTAF 150	RTAF 155	RTAF 170	RTAF 175	RTAF 185	RTAF 190	RTAF 200	RTAF 205	RTAF 245 (10)
		SE XLN	SE XLN	SE XLN	SE XLN	SE XLN	SE XLN	SE XLN	SE XLN	SE XLN	SE XLN	SE XLN	SE XLN	SE XLN	SE XLN
Max User water loop Volume for factory mounted expansion tank (1)	(l)	6000	6000	6000	NA	6000	NA	6000	NA	6000	6000	6000	6000	6000	6000
Max. Water-side Operating Pressure without pump package	(kPa)	1000	1000	1000	NA	1000	NA	1000	NA	1000	1000	1000	1000	1000	1000
Max. Water-side Operating Pressure with pump package	(kPa)	450	450	450	NA	450	NA	450	NA	450	450	450	450	450	450
Antifreeze Heater with pump package	(W)	2400	2400	2400	2400	2400	2400	2400	2800	2800	2800	2800	2800	2800	2800
Condenser															
Type		Full aluminum Micro channel heat exchanger													
Quantity	#	4/4	4/4	4/4	4/4	5/5	4/4	5/5	4/4	6/4	5/5	6/6	5/5	6/6	6/6
Face area per coil	(m ²)	2.4	2.4	2.4	2.4	2.4	2.4	2.4	2.4	2.4	2.4	2.4	2.4	2.4	2.4
Condenser Fan															
Quantity	#	4/4	4/4	4/4	4/4	5/5	4/4	5/5	5/5	6/4	5/5	6/6	5/5	6/6	6/6
Diameter	(mm)	800	800	800	800	800	800	800	800	800	800	800	800	800	800
Standard / High ambient fan option															
Fan / motor Type		Propeller fan / Fixed speed - AC motor													
Airflow per Fan	(m ³ /h)	20000	20000	20000	20000	20000	20000	20000	20000	20000	20000	20000	20000	20000	20000
Max Power input per Motor	(kW)	1.1	1.1	1.1	1.1	1.1	1.1	1.1	1.1	1.1	1.1	1.1	1.1	1.1	1.1
Max Amps per Motor	(A)	1.8	1.8	1.8	1.8	1.8	1.8	1.8	1.8	1.8	1.8	1.8	1.8	1.8	1.8
Motor RPM	(rpm)	860	860	860	860	860	860	860	860	860	860	860	860	860	860
Low ambient fan option															
Fan / motor Type		Propeller fan / Variable speed - EC motor													
Airflow per Fan	(m ³ /h)	20000	20000	20000	20000	20000	20000	20000	20000	20000	20000	20000	20000	20000	20000
Max Power input per Motor	(kW)	1.1	1.1	1.1	1.1	1.1	1.1	1.1	1.1	1.1	1.1	1.1	1.1	1.1	1.1
Max Amps per Motor	(A)	1.8	1.8	1.8	1.8	1.8	1.8	1.8	1.8	1.8	1.8	1.8	1.8	1.8	1.8
Motor RPM	(rpm)	860	860	860	860	860	860	860	860	860	860	860	860	860	860
System data (5)															
Nb of refrigerant circuit	#	2	2	2	2	2	2	2	2	2	2	2	2	2	2
Minimum cooling load % (4) (7)	%	30	30	30	30	30	30	30	30	30	30	30	30	30	30
R134a/R513A refrigerant charge Circuit 1 / Circuit 2 (8)	(kg)	41/39	40/38	42/38	42/40	45/43	44/38	47/41	54/40	57/43	56/50	59/53	60/56	63/59	63/59
Oil charge Circuit 1 / Circuit 2	(l)	6/6	6/6	6/6	6/6	6/6	7/6	7/6	7/6	7/6	7/7	7/7	8/8	8/8	8/8
POE Oil type		OIL0048E or OIL0023E													

(1) Indicative performance at Evaporator water temperature: 12°C / 7°C - Condenser air temperature 35°C- for detailed performances consult Order Write Up.

(2) Under 400V/3/50Hz.

(3) Rated Condition without Pump Package.

(4) Percent minimum load may be adjusted around 15%-20% according to operating conditions by local sales office.

(5) Electrical & system data are indicative and subject to change without notice. Please refer to unit nameplate data.

(6) Not applicable for Glycol application- see tables with Minimum Flow with Glycol.

(7) Max speed- range is 60% to 100% of max speed.

(8) Refrigerant charge may vary according to option- for instance +20% for process (digit 19 = p). For real value refer to unit nameplate.

(9) Data containing information on two circuits shown as follows: ckt1/ckt2.

(10) Size 245 not available in R513A.

General Data

Table 3b – General Data RTAF 090-185 Standard Efficiency- Extra Low Noise (XLN)- R1234 ze

		RTAF 090	RTAF 100	RTAF 110	RTAF 120	RTAF 130	RTAF 145	RTAF 155	RTAF 185
		SE XLN	SE XLN	SE XLN	SE XLN	SE XLN	SE XLN	SE XLN	SE XLN
Cooling Capacity (1)	(kW)	325	357	388	419	450	502	544	603
Unit electrical data (2) (3) (4)									
Maximum Power input in cooling	(kW)	163	177	191	202	213	243	270	274
Unit rated amps (Max compressor+fan+control)	(A)	264	287	310	331	352	399	440	446
Unit start up amps starting Amps of the larges compr+RLA of 2nd compr+RLA of all fans+control)	(A)	362	404	427	459	480	549	590	596
Displacement Power Factor (DPF)		0.89	0.89	0.89	0.88	0.87	0.88	0.89	0.89
Max power cable cross section	mm ²	1*240	1*240	1*240	1*240	1*240	2*300	2*300	2*300
Disconnect switch size	(A)	400	400	500	500	500	630	630	630
Compressor									
Quantity	#	2	2	2	2	2	2	2	2
Type		Screw	Screw	Screw	Screw	Screw	Screw	Screw	Screw
Model (9)		45/45	55/45	55/55	65/55	65/65	78/65	78/78	78/78
Max Compr Power input (Circuit 1 / Circuit 2)	kW	73/73	87/73	87/87	98/87	98/98	125/98	125/125	125/125
Max Amps Circuit1 / Circuit 2 (3) (5)	(A)	119/119	142/119	142/142	119/142	119/163	119/163	204/204	204/204
Start up Amps Circuit1 / Circuit 2 (3)(5)	(A)	217/217	259/217	259/259	291/259	291/291	354/291	354/354	354/354
Motor RPM	(rpm)	3000	3000	3000	3000	3000	3000	3000	3000
Oil sump heater Circuit1 / Circuit 2	(W)					150			
Evaporator									
Quantity	#	1	1	1	1	1	1	1	1
Type		Flooded shell and tube heat exchanger							
Evaporator model		115B	115A	115A	165C	165B	200C	200C	200B
Evaporator Water Content volume	(l)	51	58	58	64	74	89	89	99
Antifreeze Heater	(W)	1640	1640	1640	1640	1640	1640	1640	2040
Two pass evaporator									
Evap. Water Flow rate - Minimum (6)	(l/s)	8.0	9.4	9.4	11.1	11.6	13.0	13.0	14.2
Evap. Water Flow rate - Maximum	(l/s)	29.6	34.7	34.7	41.2	43.1	48.0	48.0	52.6
Nominal water connection size (Grooved coupling)	(in) - (mm)	4" - 100	4" - 100	4" - 100	5" - 125	5" - 125	6" - 150	6" - 150	6" - 150
Two pass evaporator with turbulator									
Evap. Water Flow rate - Minimum (6)	(l/s)	6.6	7.8	7.8	9.3	9.7	10.8	10.8	11.8
Evap. Water Flow rate - Maximum	(l/s)	26.6	31.2	31.2	37.0	38.7	43.1	43.1	47.2
Nominal water connection size (Grooved coupling)	(in) - (mm)	4" - 100	4" - 100	4" - 100	5" - 125	5" - 125	6" - 150	6" - 150	6" - 150
Hydraulic Module Components									
Standard head pressure pump option (twin pumps)									
Available Head Pressure (1)	(kPa)	129	126	111	107	136	121	160	151
Max. Motor Power	(kW)	5.5	5.5	5.5	5.5	7.5	7.5	11.0	11.0
Max Amps	(A)	11.0	11.0	11.0	11.0	14.4	14.4	20.8	20.8
High head pressure pump option (twin pumps)									
Available Head Pressure (1)	(kPa)	246	243	227	222	212	237	226	218
Max. Motor Power	(kW)	11.0	11.0	11.0	11.0	11.0	15.0	15.0	15.0
Max Amps	(A)	20.8	20.8	20.8	20.8	20.8	28.0	28.0	28.0
Expansion Tank Volume	(l)	80	80	80	80	80	80	80	80
Max User water loop Volume for factory mounted expansion tank (1)	(l)	6000	6000	6000	6000	6000	6000	6000	6000
Max. Water-side Operating Pressure without pump package	(kPa)	1000	1000	1000	1000	1000	1000	1000	1000
Max. Water-side Operating Pressure with pump package	(kPa)	450	450	450	450	450	450	450	450
Antifreeze Heater with pump package	(W)	2360	2360	2360	2360	2360	2360	2360	2760
Condenser									
Type									
Quantity	#	4/4	4/4	4/4	4/4	4/4	5/5	5/5	6/6
Face area per coil	(m ²)	2.4	2.4	2.4	2.4	2.4	2.4	2.4	2.4
Condenser Fan (nominal conditions)									
Quantity	#	4/4	4/4	4/4	4/4	4/4	5/5	5/5	6/6
Diameter	(mm)	800	800	800	800	800	800	800	800
Standard / High ambient fan option									
Fan / motor Type		Propeller fan / Fixed speed - AC motor							
Airflow per Fan	(m ³ /h)	20000	20000	20000	20000	20000	20000	20000	20000
Max Power input per Motor	(kW)	1.1	1.1	1.1	1.1	1.1	1.1	1.1	1.1
Max Amps per Motor	(A)	1.8	1.8	1.8	1.8	1.8	1.8	1.8	1.8
Motor RPM	(rpm)	860	860	860	860	860	860	860	860

General Data

Table 3b – General Data RTAF 090-185 Standard Efficiency - Extra Low Noise (XLN) - R1234 ze (continued)

		RTAF 090	RTAF 100	RTAF 110	RTAF 120	RTAF 130	RTAF 145	RTAF 155	RTAF 185
		SE XLN	SE XLN	SE XLN	SE XLN	SE XLN	SE XLN	SE XLN	SE XLN
Low ambient fan option									
Fan / motor Type		Propeller fan / Variable speed - EC motor							
Airflow per Fan	(m ³ /h)	20000	20000	20000	20000	20000	20000	20000	20000
Max Power input per Motor	(kW)	1.1	1.1	1.1	1.1	1.1	1.1	1.1	1.1
Max Amps per Motor	(A)	1.8	1.8	1.8	1.8	1.8	1.8	1.8	1.8
Motor RPM	(rpm)	860	860	860	860	860	860	860	860
System data									
Nb of refrigerant circuit	#	2	2	2	2	2	2	2	2
Minimum cooling load % (6)	%	30	30	30	30	30	30	30	30
Refrigerant charge Circuit1 / Circuit 2	(kg)	41/39	40/38	40/38	41/42	42/40	55/45	55/45	60/46
Oil charge Circuit1 / Circuit 2	(l)	5/5	5/5	5/5	6/5	6/6	6/6	6/6	6/6
POE Oil type (10)		OIL00317 or OIL00315							

- (1) Indicative performance at Evaporator water temperature: 12°C / 7°C - Condenser air temperature 35°C - for detailed performances consult Order Write Up.
- (2) Under 400V/3/50Hz.
- (3) Rated Condition without Pump Package.
- (4) Percent minimum load may be adjusted around 15%-20% according to operating conditions by local sales office.
- (5) Electrical & system data are indicative and subject to change without notice. Please refer to unit nameplate data.
- (6) Not applicable for Glycol application - see tables with Minimum Flow with Glycol.
- (7) Max speed - range is 60% to 100% of max speed.
- (8) Refrigerant charge may vary according to option - for instance +20% for process (digit 19 = p). For real value refer to unit nameplate.
- (9) Data containing information on two circuits shown as follows: ckt1/ckt2.
- (10) OIL0066E or OIL0067E may have been used on early orders and there is no restriction to continue to use them but preferable oil is OIL00315 or OIL00317.



General Data

Table 4a – General Data RTAF 090-245 Standard Efficiency - AC Extra Low Noise - R134a - R513A

		RTAF 090	RTAF 105	RTAF 125	RTAF 140	RTAF 145	RTAF 150	RTAF 155	RTAF 170	RTAF 175	RTAF 185	RTAF 190	RTAF 200	RTAF 205	RTAF 245 (10)
		SE AC XLN	SE AC XLN	SE AC XLN	SE AC XLN	SE AC XLN	SE AC XLN	SE AC XLN	SE AC XLN	SE AC XLN	SE AC XLN	SE AC XLN	SE AC XLN	SE AC XLN	SE AC XLN
Cooling Capacity (1)	(kW)	324	373	436	499	518	535	558	572	608	647	668	698	724	810
Unit electrical data (2) (3) (5)															
Maximum Power input in cooling	(kW)	133.1	154.3	182.5	211	213.6	233.08	236.0	255.48	258.9	281.26	284.1	304.16	307.0	307.0
Unit rated amps (Max compr +Fan+Control)	(A)	221	259	309	359	364	394	399	429	438	473	479	512	518	517
Unit start up amps (Starting Amps of the largest compr+RLA of 2nd compr+RLA of all fans+ control)	(A)	268	323	434	484	489	547	552	582	563	626	632	626	632	631
Displacement Power Factor (DPF)		0.88	0.87	0.86	0.85	0.85	0.86	0.86	0.86	0.86	0.86	0.86	0.86	0.86	0.86
Max power cable cross section	(mm ²)	1x240	1x240	1x240	2x300	2x300	2x300	2x300	2x300	2x300	2x300	2x300	2x300	2x300	2x300
Disconnect switch size	(A)	400	400	500	630	630	630	630	630	630	800	800	800	800	800
Compressor															
Quantity	#	2	2	2	2	2	2	2	2	2	2	2	2	2	2
Type		Screw	Screw	Screw	Screw	Screw	Screw	Screw	Screw	Screw	Screw	Screw	Screw	Screw	Screw
Model (9)		45/45	50/50	70/50	70/70	70/70	85/70	85/70	85/85	100/70	100/85	100/85	100/100	100/100	100/100
Max Compr Power input Circuit 1/Circuit 2	(kW)	60/60	71/71	99/71	99/72	99/99	121/98	121/99	121/121	144/99	144/121	144/121	144/144	144/144	144/144
Max Amps Circuit 1 / Circuit 2 (3) (5)	(A)	97/97	116/116	166/116	166/117	166/166	201/165	201/166	201/201	240/166	240/201	240/201	240/240	240/240	240/240
Start up Amps Circuit 1 / Circuit 2 (3) (5)	(A)	144/144	180/180	291/180	291/181	291/291	354/290	354/291	354/354	354/291	354/354	354/354	354/354	354/354	354/354
Motor RPM	(rpm)	3000	3000	3000	3000	3000	3000	3000	3000	3000	3000	3000	3000	3000	3000
Oil sump heater Circuit 1 / Circuit 2	(W)	150/150	150/150	150/150	150/150	150/150	150/150	150/150	150/150	150/150	150/150	150/150	150/150	150/150	150/150
Evaporator															
Quantity	#	1	1	1	1	1	1	1	1	1	1	1	1	1	1
Type		Flooded shell and tube heat exchanger													
Evaporator model		115B	115A	165B	165B	165B	165A	165A	200B	200B	200B	200B	250C	250C	250B
Evaporator Water Content volume	(l)	51	58	74	74	74	78	78	99	99	99	99	109	109	118
Antifreeze Heater	(W)	1640	1640	1640	1640	1640	1640	1640	2040	2040	2040	2040	2040	2040	2040
Two pass evaporator															
Evap. Water Flow rate - Minimum	(l/s)	8.0	9.4	11.6	11.6	11.6	12.4	12.4	12.4	12.4	14.2	14.2	16.2	16.2	17.9
Evap. Water Flow rate - Maximum (6)	(l/s)	29.6	34.7	43.1	43.1	43.1	46.0	46.0	46.0	46.0	52.6	52.6	60.3	60.3	66.5
Nominal water connection size (Grooved coupling)	(in) - (DN)	4" - 100	4" - 100	5" - 125	5" - 125	5" - 125	5" - 125	5" - 125	5" - 125	5" - 125	6" - 150	6" - 150	6" - 150	6" - 150	6" - 150
Two pass evaporator with turbulator															
Evap. Water Flow rate - Minimum (6)	(l/s)	6.6	7.8	9.7	9.7	9.7	10.3	10.3	10.3	10.3	11.8	11.8	13.5	13.5	14.9
Evap. Water Flow rate - Maximum	(l/s)	26.6	31.2	38.7	38.7	38.7	41.3	41.3	41.3	41.3	47.2	47.2	54.1	54.1	59.7
Nominal water connection size (Grooved coupling)	(in) - (mm)	4" - 100	4" - 100	5" - 125	5" - 125	5" - 125	5" - 125	5" - 125	5" - 125	5" - 125	6" - 150	6" - 150	6" - 150	6" - 150	6" - 150
Hydraulic Module Components															
Standard head pressure pump option (Twin pump)															
Available Head Pressure (1)	(kPa)	140	128	142	119	119	177	177	NA	173	154	154	143	143	143
Max Motor Power input	(kW)	5.5	5.5	7.5	7.5	7.5	11.0	11.0	NA	11.0	11.0	11.0	11.0	11.0	11.0
Max Amps	(A)	11	11	14	14	14	21	21	NA	21	21	21	21	21	21
High head pressure pump option (Twin Pump)															
Available Head Pressure (1)	(kPa)	252	239	223	NA	244	NA	235	NA	231	264	264	254	254	254
Max Motor Power input	(kW)	11.0	11.0	11.0	NA	15.0	NA	15.0	NA	15.0	18.5	18.5	18.5	18.5	18.5
Max Amps	(A)	21	21	21	NA	28	NA	28	NA	28	35	35	35	35	35
Expansion Tank Volume	(l)	80	80	80	NA	80	NA	80	NA	80	80	80	80	80	80



General Data

Table 4a – General Data RTAF 090-245 Standard Efficiency - AC Extra Low Noise - R134a - R513A (continued)

		RTAF 090	RTAF 105	RTAF 125	RTAF 140	RTAF 145	RTAF 150	RTAF 155	RTAF 170	RTAF 175	RTAF 185	RTAF 190	RTAF 200	RTAF 205	RTAF 245 (10)
		SE AC XLN	SE AC XLN	SE AC XLN	SE AC XLN	SE AC XLN	SE AC XLN	SE AC XLN	SE AC XLN	SE AC XLN	SE AC XLN	SE AC XLN	SE AC XLN	SE AC XLN	SE AC XLN
Max User water loop Volume for factory mounted expansion tank (1)	(l)	6000	6000	6000	NA	6000	NA	6000	NA	6000	6000	6000	6000	6000	6000
Max. Water-side Operating Pressure without pump package	(kPa)	1000	1000	1000	NA	1000	NA	1000	NA	1000	1000	1000	1000	1000	1000
Max. Water-side Operating Pressure with pump package	(kPa)	450	450	450	NA	450	NA	450	NA	450	450	450	450	450	450
Antifreeze Heater with pump package	(W)	2360	2360	2360	2360	2360	2360	2360	2760	2760	2760	2760	2760	2760	2760
Condenser															
Type		Full aluminum Micro channel heat exchanger													
Quantity	#	4/4	4/4	4/4	4/4	5/5	4/4	5/5	4/4	6/4	5/5	6/6	5/5	6/6	6/6
Face area per coil	(m ²)	2.4	2.4	2.4	2.4	2.4	2.4	2.4	2.4	2.4	2.4	2.4	2.4	2.4	2.4
Condenser Fan															
Quantity	#	4/4	4/4	4/4	4/4	5/5	4/4	5/5	5/5	6/4	5/5	6/6	5/5	6/6	6/6
Diameter	(mm)	800	800	800	800	800	800	800	800	800	800	800	800	800	800
Standard / High ambient fan option															
Fan / motor Type		Propeller fan / Fixed speed - AC motor													
Airflow per Fan	(m ³ /h)	18000	18000	18000	18000	18000	18000	18000	18000	18000	18000	18000	18000	18000	18000
Max Power input per Motor	(kW)	1.2	1.2	1.2	1.2	1.2	1.2	1.2	1.2	1.2	1.2	1.2	1.2	1.2	1.2
Max Amps per Motor	(A)	2.9	2.9	2.9	2.9	2.9	2.9	2.9	2.9	2.9	2.9	2.9	2.9	2.9	2.9
Motor RPM	(rpm)	900	900	900	900	900	900	900	900	900	900	900	900	900	900
System data (5)															
Nb of refrigerant circuit	#	2	2	2	2	2	2	2	2	2	2	2	2	2	2
Minimum cooling load % (4) (7)	%	30	30	30	30	30	30	30	30	30	30	30	30	30	30
R134a/R513A refrigerant charge Circuit 1 / Circuit 2 (8)	(kg)	41/39	40/38	42/38	42/40	45/43	44/38	47/41	54/40	57/43	56/50	59/53	60/56	63/59	63/59
Oil charge Circuit 1 / Circuit 2	(l)	6/6	6/6	6/6	6/6	6/6	7/6	7/6	7/6	7/6	7/7	7/7	8/8	8/8	8/8
POE Oil type		OIL0048E or OIL0023E													

- (1) Indicative performance at Evaporator water temperature: 12°C / 7°C- Condenser air temperature 35°C- for detailed performances consult Order Write Up.
- (2) Under 400V/3/50Hz.
- (3) Rated Condition without Pump Package.
- (4) Percent minimum load may be adjusted around 15%-20% according to operating conditions by local sales office.
- (5) Electrical & system data are indicative and subject to change without notice. Please refer to unit nameplate data.
- (6) Not applicable for Glycol application- see tables with Minimum Flow with Glycol.
- (7) Max speed- range is 60% to 100% of max speed.
- (8) Refrigerant charge may vary according to option- for instance +20% for process (digit 19 = p). For real value refer to unit nameplate.
- (9) Data containing information on two circuits shown as follows: ckt1/ckt2.
- (10) Size 245 not available in R513A.

General Data

Table 4b – General Data RTAF 090-185 Standard Efficiency - AC Extra Low Noise - R1234 ze

		RTAF	RTAF	RTAF	RTAF	RTAF	RTAF	RTAF	RTAF							
		090	100	110	120	130	145	155	185							
		SE	AC	XLN	SE	AC	XLN	SE	AC	XLN	SE	AC	XLN	SE	AC	XLN
Cooling Capacity (1)	(kW)	328	359	389	420	451	503	545	606							
Unit electrical data (2) (3) (4)																
Maximum Power input in cooling	(kW)	158.5	172.5	186.5	197.5	208.5	238.4	265.4	268.3							
Unit rated amps (Max compressor+fan+control)	(A)	263.7	286.7	309.7	330.7	351.7	398.6	439.5	445.3							
Unit start up amps starting Amps of the larges compr+RLA of 2nd compr+RLA of all fans+control)	(A)	361.7	403.7	426.7	458.7	479.7	548.5	589.5	595.3							
Displacement Power Factor (DPF)		0.87	0.87	0.87	0.87	0.87	0.87	0.87	0.87							
Max power cable cross section	mm ²	1*240	1*240	1*240	1*240	1*240	2*300	2*300	2*300							
Disconnect switch size	(A)	400	400	500	500	500	630	630	630							
Compressor																
Quantity	#	2	2	2	2	2	2	2	2							
Type		Screw	Screw	Screw	Screw	Screw	Screw	Screw	Screw							
Model (9)		45/45	55/45	55/55	65/55	65/65	78/65	78/78	78/78							
Max Compr Power input (Circuit 1 / Circuit 2)	kW	73/73	87/73	87/87	98/87	98/98	125/98	125/125	125/125							
Max Amps Circuit1 / Circuit 2 (3) (5)	(A)	119/119	142/119	142/142	163/142	163/163	204/163	204/204	204/204							
Start up Amps Circuit1 / Circuit 2 (3)(5)	(A)	217/217	259/217	259/259	291/259	291/291	354/291	354/354	354/354							
Motor RPM	(rpm)	3000	3000	3000	3000	3000	3000	3000	3000							
Oil sump heater Circuit1 / Circuit 2	(W)						150/150									
Evaporator																
Quantity	#	1	1	1	1	1	1	1	1							
Type		Flooded shell and tube heat exchanger														
Evaporator model		115B	115A	115A	165C	165B	200C	200C	200B							
Evaporator Water Content volume	(l)	51	58	58	64	74	89	89	99							
Antifreeze Heater	(W)	1.640	1.640	1.640	1.640	1.640	1.640	1.640	2.040							
Two pass evaporator																
Evap. Water Flow rate - Minimum (6)	(l/s)	8.0	9.4	9.4	11.1	11.6	13.0	13.0	14.2							
Evap. Water Flow rate - Maximum	(l/s)	29.6	34.7	34.7	41.2	43.1	48.0	48.0	52.6							
Nominal water connection size (Grooved coupling)	(in) - (mm)	4" - 100	4" - 100	4" - 100	5" - 125	5" - 125	6" - 150	6" - 150	6" - 150							
Two pass evaporator with turbulator																
Evap. Water Flow rate - Minimum (6)	(l/s)	6.6	7.8	7.8	9.3	9.7	10.8	10.8	11.8							
Evap. Water Flow rate - Maximum	(l/s)	26.6	31.2	31.2	37.0	38.7	43.1	43.1	47.2							
Nominal water connection size (Grooved coupling)	(in) - (mm)	4" - 100	4" - 100	4" - 100	5" - 125	5" - 125	6" - 150	6" - 150	6" - 150							
Hydraulic Module Components																
Standard head pressure pump option (twin pumps)																
Available Head Pressure (1)	(kPa)	129	126	111	107	136	121	160	151							
Max. Motor Power	(kW)	5.5	5.5	5.5	5.5	7.5	7.5	11.0	11.0							
Max Amps	(A)	11.0	11.0	11.0	11.0	14.4	14.4	20.8	20.8							
High head pressure pump option (twin pumps)																
Available Head Pressure (1)	(kPa)	246	243	227	222	212	237	226	218							
Max. Motor Power	(kW)	11.0	11.0	11.0	11.0	11.0	15.0	15.0	15.0							
Max Amps	(A)	20.8	20.8	20.8	20.8	20.8	28.0	28.0	28.0							
Expansion Tank Volume	(l)	80	80	80	80	80	80	80	80							
Max User water loop Volume for factory mounted expansion tank (1)	(l)	6000	6000	6000	6000	6000	6000	6000	6000							
Max. Water-side Operating Pressure without pump package	(kPa)	1000	1000	1000	1000	1000	1000	1000	1000							
Max. Water-side Operating Pressure with pump package	(kPa)	450	450	450	450	450	450	450	450							
Antifreeze Heater with pump package	(W)	2360	2360	2360	2360	2360	2360	2360	2760							
Condenser																
Type																
Quantity	#	4/4	4/4	4/4	4/4	4/4	5/5	5/5	6/6							
Face area per coil	(m ²)	2.4	2.4	2.4	2.4	2.4	2.4	2.4	2.4							
Condenser Fan (nominal conditions)																
Quantity	#	4/4	4/4	4/4	4/4	4/4	5/5	5/5	6/6							
Diameter	(mm)	800	800	800	800	800	800	800	800							
Standard / High ambient fan option																
Fan / motor Type		Propeller fan / Fixed speed - AC motor														
Airflow per Fan	(m ³ /h)	18000	18000	18000	18000	18000	18000	18000	18000							
Max Power input per Motor	(kW)	1.2	1.2	1.2	1.2	1.2	1.2	1.2	1.2							
Max Amps per Motor	(A)	2.9	2.9	2.9	2.9	2.9	2.9	2.9	2.9							
Motor RPM	(rpm)	900	900	900	900	900	900	900	900							

General Data

Table 4b – General Data RTAF 090-185 Standard Efficiency - AC Extra Low Noise - R1234 ze (continued)

		RTAF 090		RTAF 100		RTAF 110		RTAF 120		RTAF 130		RTAF 145		RTAF 155		RTAF 185	
		SE	AC XLN	SE	AC XLN	SE	AC XLN	SE	AC XLN	SE	AC XLN	SE	AC XLN	SE	AC XLN	SE	AC XLN
System data																	
Nb of refrigerant circuit	#	2	2	2	2	2	2	2	2	2	2	2	2	2	2	2	2
Minimum cooling load % (6)	%	30	30	30	30	30	30	30	30	30	30	30	30	30	30	30	30
Refrigerant charge Circuit1 / Circuit 2	(kg)	44/42	43/41	43/41	44/45	45/43	58/48	58/48	63/49								
Oil charge Circuit1 / Circuit 2	(l)	5/5	5/5	5/5	6/5	6/6	6/6	6/6	6/6								
POE Oil type (10)					OIL00317 or OIL00315												

(1) Indicative performance at Evaporator water temperature: 12°C / 7°C - Condenser air temperature 35°C- for detailed performances consult Order Write Up.

(2) Under 400V/3/50Hz.

(3) Rated Condition without Pump Package.

(4) Percent minimum load may be adjusted around 15%-20% according to operating conditions by local sales office.

(5) Electrical & system data are indicative and subject to change without notice. Please refer to unit nameplate data.

(6) Not applicable for Glycol application- see tables with Minimum Flow with Glycol.

(7) Max speed - range is 60% to 100% of max speed.

(8) Refrigerant charge may vary according to option - for instance +20% for process (digit 19 = p). For real value refer to unit nameplate.

(9) Data containing information on two circuits shown as follows: ckt1/ckt2.

(10) OIL0066E or OIL0067E may have been used on early orders and there is no restriction to continue to use them but preferable oil is OIL00315 or OIL00317.

General Data

Table 5a – General Data RTAF 090-245 High Efficiency - Standard and Low Noise - R134a - R513A

		RTAF	RTAF	RTAF	RTAF	RTAF	RTAF	RTAF	RTAF	RTAF
		090	105	125	145	155	175	190	205	245 (10)
		HE SN LN	HE SN LN	HE SN LN	HE SN LN	HE SN LN	HE SN LN	HE SN LN	HE SN LN	HE SN LN
Cooling Capacity (1)	(kW)	331	383	452	532	577	632	689	751	829
Unit electrical data (2) (3) (5)										
Total Power input in cooling	(kW)	140.1	161.3	189.5	221.4	243.8	266.7	292.8	315.7	315.7
Unit rated amps (Max compr +Fan+Control)	(A)	237	275	325	383	418	457	500	539	539
Unit start up amps (Starting Amps of the largest compr+RLA of 2nd compr+RLA of all fans+ control)	(A)	284	339	450	508	571	582	653	653	653
Unit Power factor		0.86	0.85	0.85	0.84	0.85	0.85	0.85	0.85	0.85
Max power cable cross section	(mm ²)	240	240	240	2*300	2*300	2*300	2*300	2*300	3*300
Disconnect switch size	(A)	400	400	500	630	630	630	800	800	800
Compressor										
Quantity	#	2	2	2	2	2	2	2	2	2
Type		Screw	Screw	Screw	Screw	Screw	Screw	Screw	Screw	Screw
Model (9)		45/45	50/50	70/50	70/70	85/70	100/70	100/85	100/100	100/100
Max Compr Power input Circuit 1/ Circuit 2	kW	60/60	71/71	99/71	99/99	121/99	144/99	144/121	144/144	144/144
Max Amps Circuit 1 / Circuit 2 (3) (5)	(A)	97/97	116/116	166/116	166/166	201/166	240/166	240/201	240/240	240/240
Start up Amps Circuit 1 / Circuit 2 (3) (5)	(A)	144/144	180/180	291/180	291/291	354/291	354/291	354/354	354/354	354/354
Motor RPM	(rpm)	3000	3000	3000	3000	3000	3000	3000	3000	3000
Oil sump heater Circuit 1 / Circuit 2	(W)	150/150	150/150	150/150	150/150	150/150	150/150	150/150	150/150	150/150
Evaporator										
Quantity	#	1	1	1	1	1	1	1	1	1
Type		Flooded shell and tube heat exchanger								
Evaporator model		115B	115A	165B	165B	165A	200B	200B	250B	250B
Evaporator Water Content volume	(l)	51	58	74	74	78	99	99	118	118
Antifreeze Heater	(W)	1640	1640	1640	1640	1640	2040	2040	2040	2040
Two pass evaporator										
Evap. Water Flow rate - Minimum	(l/s)	8.0	9.4	11.6	11.6	12.4	14.2	14.2	17.9	17.9
Evap. Water Flow rate - Maximum (6)	(l/s)	29.6	34.7	43.1	43.1	46.0	52.6	52.6	66.5	66.5
Nominal water connection size (Grooved coupling)	(in) - (DN)	4" - 100	4" - 100	5" - 125	5" - 125	5" - 125	6" - 150	6" - 150	6" - 150	6" - 150
Two pass evaporator with turbulator										
Evap. Water Flow rate - Minimum (6)	(l/s)	6.6	7.8	9.7	9.7	10.3	11.8	11.8	14.9	14.9
Evap. Water Flow rate - Maximum	(l/s)	26.6	31.2	38.7	38.7	41.3	47.2	47.2	59.7	59.7
Nominal water connection size (Grooved coupling)	(in) - (mm)	4" - 100	4" - 100	5" - 125	5" - 125	5" - 125	6" - 150	6" - 150	6" - 150	6" - 150
Hydraulic Module Components										
Standard head pressure pump option										
Available Head Pressure (1)	(kPa)	139	126	137	115	174	169	150	144	144
Max Motor Power input	(kW)	5.5	5.5	7.5	7.5	11.0	11.0	11.0	11.0	11.0
Max Amps	(A)	11.0	11.0	14.0	14.0	21.0	21.0	21.0	21.0	21.0
High head pressure pump option										
Available Head Pressure (1)	(kPa)	250	237	219	242	232	226	261	256	256
Max Motor Power input	(kW)	11.0	11.0	11.0	15.0	15.0	15.0	18.5	18.5	18.5
Max Amps	(A)	21.0	21.0	21.0	28.0	28.0	28.0	35.0	35.0	35.0
Expansion Tank Volume	(l)	80	80	80	80	80	80	80	80	80
Max User water loop Volume for factory mounted expansion tank (1)	(l)	6000	6000	6000	6000	6000	6000	6000	6000	6000
Max. Water-side Operating Pressure without pump package	(kPa)	1000	1000	1000	1000	1000	1000	1000	1000	1000
Max. Water-side Operating Pressure with pump package	(kPa)	450	450	450	450	450	450	450	450	450
Antifreeze Heater with pump package	(W)	2360	2360	2360	2360	2360	2760	2760	2760	2760

General Data

Table 5a – General Data RTAF 090-245 High Efficiency - Standard and Low Noise - R134a - R513A (continued)

		RTAF 090	RTAF 105	RTAF 125	RTAF 145	RTAF 155	RTAF 175	RTAF 190	RTAF 205	RTAF 245 (10)
		HE SN LN	HE SN LN	HE SN LN	HE SN LN	HE SN LN	HE SN LN	HE SN LN	HE SN LN	HE SN LN
Condenser										
Type		Full aluminum Micro channel heat exchanger								
Quantity	#	5/5	5/5	5/5	6/6	6/6	7/5	7/7	7/7	6/6
Face area per coil	(m ²)	2.4	2.4	2.4	2.4	2.4	2.4	2.4	2.4	2.4
Condenser Fan										
Quantity	#	5/5	5/5	5/5	6/6	6/6	7/5	7/7	7/7	6/6
Diameter	(mm)	800	800	800	800	800	800	800	800	800
Standard / High ambient fan option										
Fan / motor Type		Propeller fan / Fixed speed - AC motor								
Airflow per Fan	(m ³ /h)	20000	20000	20000	20000	20000	20000	20000	20000	20000
Max Power input per Motor	(kW)	1.4	1.4	1.4	1.4	1.4	1.4	1.4	1.4	1.4
Max Amps per Motor	(A)	3.4	3.4	3.4	3.4	3.4	3.4	3.4	3.4	3.4
Motor RPM	(rpm)	932	932	932	932	932	932	932	932	932
System data (5)										
Nb of refrigerant circuit	#	2	2	2	2	2	2	2	2	2
Minimum cooling load % (4) (7)	%	30	30	30	30	30	30	30	30	30
R134a/R513A refrigerant charge Circuit 1 / Circuit 2 (8)	(kg)	43/41	42/40	45/41	48/46	50/44	60/46	62/56	66/62	66/62
Oil charge Circuit 1 / Circuit 2	(l)	6/6	6/6	6/6	6/6	7/6	7/6	7/7	8/8	8/8
POE Oil type		OIL0048E or OIL0023E								

- (1) Indicative performance at Evaporator water temperature: 12°C / 7°C - Condenser air temperature 35°C- for detailed performances consult Order Write Up.
(2) Under 400V/3/50Hz.
(3) Rated Condition without Pump Package.
(4) Percent minimum load may be adjusted around 15%-20% according to operating conditions by local sales office.
(5) Electrical & system data are indicative and subject to change without notice. Please refer to unit nameplate data.
(6) Not applicable for Glycol application - see tables with Minimum Flow with Glycol.
(7) Max speed - range is 60% to 100% of max speed.
(8) Refrigerant charge may vary according to option - for instance +20% for process (digit 19=P). For real value refer to unit nameplate.
(9) Data containing information on two circuits shown as follows: ckt1/ckt2.
(10) Size 245 not available in R513A.

General Data

Table 5b – General Data RTAF 090-185 High Efficiency - Standard and Low Noise - R1234 ze

		RTAF	RTAF	RTAF	RTAF	RTAF	RTAF	RTAF	RTAF							
		090	100	110	120	130	145	155	185							
		SE	AC	XLN	SE	AC	XLN	SE	AC	XLN	SE	AC	XLN	SE	AC	XLN
Cooling Capacity (1)	(kW)	331	365	397	430	463	512	557	614							
Unit electrical data (2) (3) (4)																
Maximum Power input in cooling	(kW)	165	179	193	204	215	246	273	277							
Unit rated amps (Max compressor+fan+control)	(A)	280	303	326	347	368	417	458	466							
Unit start up amps starting Amps of the larges compr+RLA of 2nd compr+RLA of all fans+control)	(A)	378	420	443	475	496	567	608	616							
Displacement Power Factor (DPF)		0.86	0.86	0.86	0.86	0.85	0.86	0.87	0.86							
Max power cable cross section	mm ²	1*240	1*240	1*240	1*240	1*240	2*300	2*300	2*300							
Disconnect switch size	(A)	400	400	500	500	500	630	630	630							
Compressor																
Quantity	#	2	2	2	2	2	2	2	2							
Type		Screw	Screw	Screw	Screw	Screw	Screw	Screw	Screw							
Model (9)		45/45	55/45	55/55	65/55	65/65	78/65	78/78	78/78							
Max Compr Power input (Circuit 1 / Circuit 2)	kW	73/73	87/73	87/87	98/87	98/98	125/98	125/125	125/125							
Max Amps Circuit1 / Circuit 2 (3) (5)	(A)	119/119	142/119	142/142	163/142	163/163	204/163	204/204	204/204							
Start up Amps Circuit1 / Circuit 2 (3)(5)	(A)	217/217	259/217	259/259	291/259	291/291	354/291	354/354	354/354							
Motor RPM	(rpm)	3000	3000	3000	3000	3000	3000	3000	3000							
Oil sump heater Circuit1 / Circuit 2	(W)						150/150									
Evaporator																
Quantity	#	1	1	1	1	1	1	1	1							
Type		Flooded shell and tube heat exchanger														
Evaporator model		115B	115A	115A	165C	165B	200C	200C	200B							
Evaporator Water Content volume	(l)	51	58	58	64	74	89	89	99							
Antifreeze Heater	(W)	1640	1640	1640	1640	1640	1640	1640	2040							
Two pass evaporator																
Evap. Water Flow rate - Minimum (6)	(l/s)	8.0	9.4	9.4	11.1	11.6	13.0	13.0	14.2							
Evap. Water Flow rate - Maximum	(l/s)	29.6	34.7	34.7	41.2	43.1	48.0	48.0	52.6							
Nominal water connection size (Grooved coupling)	(in) - (mm)	4" - 100	4" - 100	4" - 100	5" - 125	5" - 125	6" - 150	6" - 150	6" - 150							
Two pass evaporator with turbulator																
Evap. Water Flow rate - Minimum (6)	(l/s)	6.6	7.8	7.8	9.3	9.7	10.8	10.8	11.8							
Evap. Water Flow rate - Maximum	(l/s)	26.6	31.2	31.2	37.0	38.7	43.1	43.1	47.2							
Nominal water connection size (Grooved coupling)	(in) - (mm)	4" - 100	4" - 100	4" - 100	5" - 125	5" - 125	6" - 150	6" - 150	6" - 150							
Hydraulic Module Components																
Standard head pressure pump option (twin pumps)																
Available Head Pressure (1)	(kPa)	129	126	111	107	136	121	160	151							
Max. Motor Power	(kW)	5.5	5.5	5.5	5.5	7.5	7.5	11.0	11.0							
Max Amps	(A)	11	11	11	11	14	14	21	21							
High head pressure pump option (twin pumps)																
Available Head Pressure (1)	(kPa)	246	243	227	222	212	237	226	218							
Max. Motor Power	(kW)	11.0	11.0	11.0	11.0	11.0	15.0	15.0	15.0							
Max Amps	(A)	21	21	21	21	21	28	28	28							
Expansion Tank Volume	(l)	80	80	80	80	80	80	80	80							
Max User water loop Volume for factory mounted expansion tank (1)	(l)	6000	6000	6000	6000	6000	6000	6000	6000							
Max. Water-side Operating Pressure without pump package	(kPa)	1000	1000	1000	1000	1000	1000	1000	1000							
Max. Water-side Operating Pressure with pump package	(kPa)	450	450	450	450	450	450	450	450							
Antifreeze Heater with pump package	(W)	2360	2360	2360	2360	2360	2360	2360	2760							
Condenser																
Type																
Quantity	#	5/5	5/5	5/5	5/5	5/5	6/6	6/6	7/7							
Face area per coil	(m ²)	2.4	2.4	2.4	2.4	2.4	2.4	2.4	2.4							
Condenser Fan (nominal conditions)																
Quantity	#	5/5	5/5	5/5	5/5	5/5	6/6	6/6	7/7							
Diameter	(mm)	800	800	800	800	800	800	800	800							
Standard / High ambient fan option																
Fan / motor Type		Propeller fan / Fixed speed - AC motor														
Airflow per Fan	(m ³ /h)	20000	20000	20000	20000	20000	20000	20000	20000							
Max Power input per Motor	(kW)	1.4	1.4	1.4	1.4	1.4	1.4	1.4	1.4							
Max Amps per Motor	(A)	3.4	3.4	3.4	3.4	3.4	3.4	3.4	3.4							
Motor RPM	(rpm)	932	932	932	932	932	932	932	932							

General Data

Table 5b – General Data RTAF 090-185 High Efficiency - Standard and Low Noise - R1234 ze (continued)

		RTAF 090		RTAF 100		RTAF 110		RTAF 120		RTAF 130		RTAF 145		RTAF 155		RTAF 185		
		SE	AC XLN	SE	AC XLN	SE	AC XLN	SE	AC XLN	SE	AC XLN	SE	AC XLN	SE	AC XLN	SE	AC XLN	
System data																		
Nb of refrigerant circuit	#	2	2	2	2	2	2	2	2	2	2	2	2	2	2	2	2	
Minimum cooling load % (6)	%	30	30	30	30	30	30	30	30	30	30	30	30	30	30	30	30	
Refrigerant charge Circuit1 / Circuit 2	(kg)	44/42	43/41	43/41	44/45	45/43	58/48	58/48	63/49									
Oil charge Circuit1 / Circuit 2	(l)	5/5	5/5	5/5	6/5	6/6	6/6	6/6	6/6									
POE Oil type (10)		OIL00317 or OIL00315																

(1) Indicative performance at Evaporator water temperature: 12°C / 7°C - Condenser air temperature 35°C- for detailed performances consult Order Write Up.

(2) Under 400V/3/50Hz.

(3) Rated Condition without Pump Package.

(4) Percent minimum load may be adjusted around 15%-20% according to operating conditions by local sales office.

(5) Electrical & system data are indicative and subject to change without notice. Please refer to unit nameplate data.

(6) Not applicable for Glycol application- see tables with Minimum Flow with Glycol.

(7) Max speed - range is 60% to 100% of max speed.

(8) Refrigerant charge may vary according to option - for instance +20% for process (digit 19 = p). For real value refer to unit nameplate.

(9) Data containing information on two circuits shown as follows: ckt1/ckt2.

(10) OIL0066E or OIL0067E may have been used on early orders and there is no restriction to continue to use them but preferable oil is OIL00315 or OIL00317.

General Data

Table 6a – General Data RTAF 090-205 High Efficiency- AC Extra Low Noise - R134a - R513A

		RTAF 090	RTAF 105	RTAF 125	RTAF 145	RTAF 155	RTAF 175	RTAF 190	RTAF 205
		HE AC XLN	HE AC XLN	HE AC XLN	HE AC XLN	HE AC XLN	HE AC XLN	HE AC XLN	HE AC XLN
Cooling Capacity (1)	(kW)	330	381	450	529	572	627	683	744
Unit electrical data (2) (3) (5)									
Maximum Power input in cooling	(kW)	136	157	185	216	239	262	287	310
Unit rated amps (Max compr +Fan+Control)	(A)	226	264	314	370	405	444	485	524
Unit start up amps (Starting Amps of the largest compr+RLA of 2nd compr+RLA of all fans+ control)	(A)	273	328	439	495	558	569	638	638
Displacement Power Factor (DPF)		0.88	0.86	0.86	0.85	0.86	0.85	0.86	0.86
Max power cable cross section	(mm ²)	1x240	1x240	1x240	2x300	2x300	2x300	2x300	2x300
Disconnect switch size	(A)	400	400	500	630	630	800	800	800
Compressor									
Quantity	#	2	2	2	2	2	2	2	2
Type		Screw	Screw	Screw	Screw	Screw	Screw	Screw	Screw
Model (9)		45/45	50/50	70/50	70/70	85/70	100/70	100/85	100/100
Max Compr Power input Circuit 1/Circuit 2	kW	60/60	71/71	99/71	99/99	121/99	144/99	144/121	144/144
Max Amps Circuit 1 / Circuit 2 (3) (5)	(A)	97/97	116/116	166/116	166/166	201/166	240/166	240/201	240/240
Start up Amps Circuit 1 / Circuit 2 (3) (5)	(A)	144/144	180/180	291/180	291/291	354/291	354/291	354/354	354/354
Motor RPM	(rpm)	3000	3000	3000	3000	3000	3000	3000	3000
Oil sump heater Circuit 1 / Circuit 2	(W)	150/150	150/150	150/150	150/150	150/154	150/150	150/150	150/150
Evaporator									
Quantity	#	1	1	1	1	1	1	1	1
Type		Flooded shell and tube heat exchanger							
Evaporator model		115B	115A	165B	165B	165A	200B	200B	250B
Evaporator Water Content volume	(l)	51	58	74	74	78	99	99	118
Antifreeze Heater	(W)	1640	1640	1640	1640	1640	2040	2040	2040
Two pass evaporator									
Evap. Water Flow rate - Minimum	(l/s)	8.0	9.4	11.6	11.6	12.4	14.2	14.2	17.9
Evap. Water Flow rate - Maximum (6)	(l/s)	29.6	34.7	43.1	43.1	46.0	52.6	52.6	66.5
Nominal water connection size (Grooved coupling)	(in) - (DN)	4" - 100	4" - 100	5" - 125	5" - 125	5" - 125	6" - 150	6" - 150	6" - 150
Two pass evaporator with turbulator									
Evap. Water Flow rate - Minimum (6)	(l/s)	6.6	7.8	9.7	9.7	10.3	11.8	11.8	14.9
Evap. Water Flow rate - Maximum	(l/s)	26.6	31.2	38.7	38.7	41.3	47.2	47.2	59.7
Nominal water connection size (Grooved coupling)	(in) - (mm)	4" - 100	4" - 100	5" - 125	5" - 125	5" - 125	6" - 150	6" - 150	6" - 150
Hydraulic Module Components									
Standard head pressure pump option (Twin pump)									
Available Head Pressure (1)	(kPa)	139	126	137	115	174	169	150	144
Max Motor Power input	(kW)	5.5	5.5	7.5	7.5	11.0	11.0	11.0	11.0
Max Amps	(A)	11	11	14	14	21	21	21	21
High head pressure pump option (Twin Pump)									
Available Head Pressure (1)	(kPa)	250	237	219	242	232	226	261	256
Max Motor Power input	(kW)	11.0	11.0	11.0	15.0	15.0	15.0	18.5	18.5
Max Amps	(A)	21	21	21	28	28	28	35	35
Expansion Tank Volume	(l)	80	80	80	80	80	80	80	80
Max User water loop Volume for factory mounted expansion tank (1)	(l)	6000	6000	6000	6000	6000	6000	6000	6000
Max. Water-side Operating Pressure without pump package	(kPa)	1000	1000	1000	1000	1000	1000	1000	1000
Max. Water-side Operating Pressure with pump package	(kPa)	450	450	450	450	450	450	450	450
Antifreeze Heater with pump package	(W)	2360	2360	2360	2360	2360	2760	2760	2760
Condenser									
Type		Full aluminum Micro channel heat exchanger							
Quantity	#	5/5	5/5	5/5	6/6	6/6	7/5	7/7	7/7
Face area per coil	(m ²)	2.4	2.4	2.4	2.4	2.4	2.4	2.4	2.4
Condenser Fan									
Quantity	#	5/5	5/5	5/5	6/6	6/6	7/5	7/7	7/7
Diameter	(mm)	800	800	800	800	800	800	800	800
Standard / High ambient fan option									
Fan / motor Type		Propeller fan / Fixed speed - AC motor							
Airflow per Fan	(m ³ /h)	20000	20000	20000	20000	20000	20000	20000	20000
Max Power input per Motor	(kW)	1.40	1.40	1.40	1.40	1.40	1.40	1.40	1.40
Max Amps per Motor	(A)	3.4	3.4	3.4	3.4	3.4	3.4	3.4	3.4
Motor RPM	(rpm)	932	932	932	932	932	932	932	932

General Data

Table 6a – General Data RTAF 090-205 High Efficiency- AC Extra Low Noise - R134a - R513A (continued)

		RTAF 090	RTAF 105	RTAF 125	RTAF 145	RTAF 155	RTAF 175	RTAF 190	RTAF 205
		HE AC XLN	HE AC XLN	HE AC XLN	HE AC XLN	HE AC XLN	HE AC XLN	HE AC XLN	HE AC XLN
Low ambient fan option									
Fan / motor Type		Propeller fan / Fix speed - AC motor							
Airflow per Fan	(m ³ /h)	18000	18000	18000	18000	18000	18000	18000	18000
Max Power input per Motor	(kW)	1.2	1.2	1.2	1.2	1.2	1.2	1.2	1.2
Max Amps per Motor	(A)	2.9	2.9	2.9	2.9	2.9	2.9	2.9	2.9
Motor RPM	(rpm)	900	900	900	900	900	900	900	900
System data (5)									
Nb of refrigerant circuit	#	2	2	2	2	2	2	2	2
Minimum cooling load % (4) (7)	%	30	30	30	30	30	30	30	30
R134a/R513A refrigerant charge Circuit 1 / Circuit 2 (8)	(kg)	43/41	42/40	45/41	48/46	50/44	60/46	62/56	66/62
Oil charge Circuit 1 / Circuit 2	(l)	6/6	6/6	6/6	6/6	7/6	7/6	7/7	8/8
POE Oil type		OIL0048E or OIL0023E							

- (1) Indicative performance at Evaporator water temperature: 12°C / 7°C- Condenser air temperature 35°C- for detailed performances consult Order Write Up.
- (2) Under 400V/3/50Hz.
- (3) Rated Condition without Pump Package.
- (4) Percent minimum load may be adjusted around 15%-20% according to operating conditions by local sales office.
- (5) Electrical & system data are indicative and subject to change without notice. Please refer to unit nameplate data.
- (6) Not applicable for Glycol application- see tables with Minimum Flow with Glycol.
- (7) Max speed - range is 60% to 100% of max speed.
- (8) Refrigerant charge may vary according to option- for instance +20% for process (digit 19 = p). For real value refer to unit nameplate.
- (9) Data containing information on two circuits shown as follows: ckt1/ckt2.

General Data

Table 6b – General Data RTAF 090-185 High Efficiency- AC Extra Low Noise - R1234 ze

		RTAF 090	RTAF 100	RTAF 110	RTAF 120	RTAF 130	RTAF 145	RTAF 155	RTAF 185
		HE AC XLN	HE AC XLN	HE AC XLN	HE AC XLN	HE AC XLN	HE AC XLN	HE AC XLN	HE AC XLN
Cooling Capacity (1)	(kW)	328	360	392	424	457	506	549	607
Unit electrical data (2) (3) (4)									
Maximum Power input in cooling	(kW)	161	175	189	200	211	241	268	271
Unit rated amps (Max compressor+fan+control)	(A)	269	292	315	336	357	404	445	451
Unit start up amps starting Amps of the larges compr+RLA of 2nd compr+RLA of all fans+control)	(A)	367	409	432	464	485	554	595	601
Displacement Power Factor (DPF)		0.87	0.87	0.87	0.86	0.86	0.87	0.87	0.87
Max power cable cross section	mm ²	1*240	1*240	1*240	1*240	1*240	2*300	2*300	2*300
Disconnect switch size	(A)	400	400	500	500	500	630	630	630
Compressor									
Quantity	#	2	2	2	2	2	2	2	2
Type		Screw	Screw	Screw	Screw	Screw	Screw	Screw	Screw
Model (9)		45/45	55/45	55/55	65/55	65/65	78/65	78/78	78/78
Max Compr Power input (Circuit 1 / Circuit 2)	kW	73/73	87/73	87/87	98/87	98/98	125/98	125/125	125/125
Max Amps Circuit1 / Circuit 2 (3) (5)	(A)	119/119	142/119	142/142	163/142	163/163	204/163	204/204	204/204
Start up Amps Circuit1 / Circuit 2 (3)(5)	(A)	217/217	259/217	259/259	291/259	291/291	354/291	354/354	354/354
Motor RPM	(rpm)	3000	3000	3000	3000	3000	3000	3000	3000
Oil sump heater Circuit1 / Circuit 2	(W)					150/150			
Evaporator									
Quantity	#	1	1	1	1	1	1	1	1
Type		Flooded shell and tube heat exchanger							
Evaporator model		115B	115A	115A	165C	165B	200C	200C	200B
Evaporator Water Content volume	(l)	51	58	58	64	74	89	89	99
Antifreeze Heater	(W)	1640	1640	1640	1640	1640	1640	1640	2040
Two pass evaporator									
Evap. Water Flow rate - Minimum (6)	(l/s)	8.0	9.4	9.4	11.1	11.6	13.0	13.0	14.2
Evap. Water Flow rate - Maximum	(l/s)	29.6	34.7	34.7	41.2	43.1	48.0	48.0	52.6
Nominal water connection size (Grooved coupling)	(in) - (mm)	4" - 100	4" - 100	4" - 100	5" - 125	5" - 125	6" - 150	6" - 150	6" - 150
Two pass evaporator with turbulator									
Evap. Water Flow rate - Minimum (6)	(l/s)	6.6	7.8	7.8	9.3	9.7	10.8	10.8	11.8
Evap. Water Flow rate - Maximum	(l/s)	26.6	31.2	31.2	37.0	38.7	43.1	43.1	47.2
Nominal water connection size (Grooved coupling)	(in) - (mm)	4" - 100	4" - 100	4" - 100	5" - 125	5" - 125	6" - 150	6" - 150	6" - 150
Hydraulic Module Components									
Standard head pressure pump option (twin pumps)									
Available Head Pressure (1)	(kPa)	129	126	111	107	136	121	160	151
Max. Motor Power	(kW)	5.5	5.5	5.5	5.5	7.5	7.5	11.0	11.0
Max Amps	(A)	11	11	11	11	14	14	21	21
High head pressure pump option (twin pumps)									
Available Head Pressure (1)	(kPa)	246	243	227	222	212	237	226	218
Max. Motor Power	(kW)	11.0	11.0	11.0	11.0	11.0	15.0	15.0	15.0
Max Amps	(A)	21	21	21	21	21	28	28	28
Expansion Tank Volume	(l)	80	80	80	80	80	80	80	80
Max User water loop Volume for factory mounted expansion tank (1)	(l)	6000	6000	6000	6000	6000	6000	6000	6000
Max. Water-side Operating Pressure without pump package	(kPa)	1000	1000	1000	1000	1000	1000	1000	1000
Max. Water-side Operating Pressure with pump package	(kPa)	450	450	450	450	450	450	450	450
Antifreeze Heater with pump package	(W)	2360	2360	2360	2360	2360	2360	2360	2760
Condenser									
Type									
Quantity	#	5/5	5/5	5/5	5/5	5/5	6/6	6/6	7/7
Face area per coil	(m ²)	2.4	2.4	2.4	2.4	2.4	2.4	2.4	2.4
Condenser Fan (nominal conditions)									
Quantity	#	5/5	5/5	5/5	5/5	5/5	6/6	6/6	7/7
Diameter	(mm)	800	800	800	800	800	800	800	800
Standard / High ambient fan option									
Fan / motor Type		Propeller fan / Fixed speed - AC motor							
Airflow per Fan	(m ³ /h)	18000	18000	18000	18000	18000	18000	18000	18000
Max Power input per Motor	(kW)	1.2	1.2	1.2	1.2	1.2	1.2	1.2	1.2
Max Amps per Motor	(A)	2.9	2.9	2.9	2.9	2.9	2.9	2.9	2.9
Motor RPM	(rpm)	900	900	900	900	900	900	900	900

General Data

Table 6b – General Data RTAF 090-185 High Efficiency- AC Extra Low Noise - R1234 ze (continued)

		RTAF 090	RTAF 100	RTAF 110	RTAF 120	RTAF 130	RTAF 145	RTAF 155	RTAF 185
		HE AC XLN	HE AC XLN	HE AC XLN	HE AC XLN	HE AC XLN	HE AC XLN	HE AC XLN	HE AC XLN
Low ambient fan option									
Fan / motor Type		Propeller fan / Variable speed - EC motor							
Airflow per Fan	(m ³ /h)	18000	18000	18000	18000	18000	18000	18000	18000
Max Power input per Motor	(kW)	1.2	1.2	1.2	1.2	1.2	1.2	1.2	1.2
Max Amps per Motor	(A)	2.9	2.9	2.9	2.9	2.9	2.9	2.9	2.9
Motor RPM	(rpm)	900	900	900	900	900	900	900	900
System data									
Nb of refrigerant circuit	#	2	2	2	2	2	2	2	2
Minimum cooling load % (6)	%	30	30	30	30	30	30	30	30
Refrigerant charge Circuit 1 / Circuit 2 (8)	(kg)	44/42	43/41	43/41	44/45	45/43	58/48	58/48	63/49
Oil charge Circuit 1 / Circuit 2	(l)	5/5	5/5	5/5	6/5	6/6	6/6	6/6	6/6
POE Oil type (10)		OIL00317 or OIL00315							

(1) Indicative performance at Evaporator water temperature: 12°C / 7°C - Condenser air temperature 35°C - for detailed performances consult Order Write Up.

(2) Under 400V/3/50Hz.

(3) Rated Condition without Pump Package.

(4) Percent minimum load may be adjusted around 15%-20% according to operating conditions by local sales office.

(5) Electrical & system data are indicative and subject to change without notice. Please refer to unit nameplate data.

(6) Not applicable for Glycol application - see tables with Minimum Flow with Glycol.

(7) Max speed - range is 60% to 100% of max speed.

(8) Refrigerant charge may vary according to option - for instance +20% for process (digit 19 = p). For real value refer to unit nameplate.

(9) Data containing information on two circuits shown as follows: ckt1/ckt2.

(10) OIL0066E or OIL0067E may have been used on early orders and there is no restriction to continue to use them but preferable oil is OIL00315 or OIL00317.

General Data

Table 7a – General Data RTAF 090-205 Extra Efficiency - Standard and Low Noise - R134a - R513A

		RTAF 090	RTAF 105	RTAF 125	RTAF 145	RTAF 155	RTAF 175	RTAF 190	RTAF 205
		XE SN LN	XE SN LN	XE SN LN	XE SN LN	XE SN LN	XE SN LN	XE SN LN	XE SN LN
Cooling Capacity (1)	(kW)	326	380	447	526	569	633	690	752
Unit electrical data (2) (3) (5)									
Maximum Power input in cooling	(kW)	141.1	162.3	190.5	222.6	245.0	267.9	294.2	317.1
Unit rated amps (Max compr +Fan+Control)	(A)	227	265	315	371	406	445	486	525
Unit start up amps (Starting Amps of the largest compr+RLA of 2nd compr+RLA of all fans+ control)	(A)	274	329	440	496	559	570	639	639
Unit Power factor		0.90	0.89	0.88	0.87	0.87	0.87	0.88	0.87
Max power cable cross section	(mm ²)	240	240	240	2*300	2*300	2*300	2*300	2*300
Disconnect switch size	(A)	400	400	500	630	630	630	800	800
Compressor									
Quantity	#	2	2	2	2	2	2	2	2
Type		Screw	Screw	Screw	Screw	Screw	Screw	Screw	Screw
Model (9)		45/45	50/50	70/50	70/70	85/70	100/70	100/85	100/100
Max Compr Power input Circuit 1/Circuit 2	kW	60/60	71/71	99/71	99/99	121/99	144/99	144/121	144/144
Max Amps Circuit 1 / Circuit 2 (3) (5)	(A)	97/97	116/116	166/116	166/166	201/166	240/166	240/201	240/240
Start up Amps Circuit 1 / Circuit 2 (3) (5)	(A)	144/144	180/180	291/180	291/291	354/291	354/291	354/354	354/354
Motor RPM	(rpm)	3000	3000	3000	3000	3000	3000	3000	3000
Oil sump heater Circuit 1 / Circuit 2	(W)	150/150	150/150	150/150	150/150	150/150	150/150	150/150	150/150
Evaporator									
Quantity	#	1	1	1	1	1	1	1	1
Type		Flooded shell and tube heat exchanger							
Evaporator model		115B	115A	165B	165B	165A	200B	200B	250B
Evaporator Water Content volume	(l)	51	58	74	74	78	99	99	118
Antifreeze Heater	(W)	1640	1640	1640	1640	1640	2040	2040	2040
Two pass evaporator									
Evap. Water Flow rate - Minimum	(l/s)	8.0	9.4	11.6	11.6	12.4	14.2	14.2	17.9
Evap. Water Flow rate - Maximum (6)	(l/s)	29.6	34.7	43.1	43.1	46.0	52.6	52.6	66.5
Nominal water connection size (Grooved coupling)	(in) - (DN)	4" - 100	4" - 100	5" - 125	5" - 125	5" - 125	6" - 150	6" - 150	6" - 150
Two pass evaporator with turbulator									
Evap. Water Flow rate - Minimum (6)	(l/s)	6.6	7.8	9.7	9.7	10.3	11.8	11.8	14.9
Evap. Water Flow rate - Maximum	(l/s)	26.6	31.2	38.7	38.7	41.3	47.2	47.2	59.7
Nominal water connection size (Grooved coupling)	(in) - (mm)	4" - 100	4" - 100	5" - 125	5" - 125	5" - 125	6" - 150	6" - 150	6" - 150
Hydraulic Module Components									
Standard head pressure pump option									
Available Head Pressure (1)	(kPa)	141	128	142	121	179	172	153	149
Max Motor Power input	(kW)	5.5	5.5	7.5	7.5	11.0	11.0	11.0	11.0
Max Amps	(A)	11.0	11.0	14.4	14.4	20.8	20.8	20.8	20.8
High head pressure pump option									
Available Head Pressure (1)	(kPa)	253	239	224	245	237	230	264	260
Max Motor Power input	(kW)	11.0	11.0	11.0	15.0	15.0	15.0	18.5	18.5
Max Amps	(A)	20.8	20.8	20.8	28.0	28.0	28.0	34.5	34.5
Expansion Tank Volume	(l)	80	80	80	80	80	80	80	80
Max User water loop Volume for factory mounted expansion tank (1)	(l)	6000	6000	6000	6000	6000	6000	6000	6000
Max. Water-side Operating Pressure without pump package	(kPa)	1000	1000	1000	1000	1000	1000	1000	1000
Max. Water-side Operating Pressure with pump package	(kPa)	450	450	450	450	450	450	450	450
Antifreeze Heater with pump package	(W)	2360	2360	2360	2360	2360	2760	2760	2760
Condenser									
Type		Full aluminum Micro channel heat exchanger							
Quantity	#	5/5	5/5	5/5	6/6	6/6	7/5	7/7	7/7
Face area per coil	(m ²)	2.4	2.4	2.4	2.4	2.4	2.4	2.4	2.4
Condenser Fan									
Quantity	#	5/5	5/5	5/5	6/6	6/6	7/5	7/7	7/7
Diameter	(mm)	800	800	800	800	800	800	800	800
Standard / High ambient fan option									
Fan / motor Type		Propeller fan / Variable speed - EC motor							
Airflow per Fan	(m ³ /h)	15000	17400	17400	17400	17400	20000	20000	20000
Max Power input per Motor	(kW)	0.6	0.9	0.9	0.9	0.9	1.3	1.3	1.3
Max Amps per Motor	(A)	1.1	1.6	1.6	1.6	1.6	2.3	2.3	2.3
Motor RPM	(rpm)	710	810	810	810	810	910	910	910

General Data

Table 7a – General Data RTAF 090-205 Extra Efficiency - Standard and Low Noise - R134a - R513A (continued)

		RTAF 090	RTAF 105	RTAF 125	RTAF 145	RTAF 155	RTAF 175	RTAF 190	RTAF 205
		XE SN LN	XE SN LN	XE SN LN	XE SN LN	XE SN LN	XE SN LN	XE SN LN	XE SN LN
Low ambient fan option									
Fan / motor Type		Propeller fan / Variable speed - EC motor							
Airflow per Fan	(m ³ /h)	15000	17400	17400	17400	17400	20000	20000	20000
Max Power input per Motor	(kW)	0.6	0.9	0.9	0.9	0.9	1.3	1.3	1.3
Max Amps per Motor	(A)	1.1	1.6	1.6	1.6	1.6	2.3	2.3	2.3
Motor RPM	(rpm)	710	810	810	810	810	910	910	910
System data (5)									
Nb of refrigerant circuit	#	2	2	2	2	2	2	2	2
Minimum cooling load % (4) (7)	%	30	30	30	30	30	30	30	30
R134a/R513A refrigerant charge Circuit 1 / Circuit 2 (8)	(kg)	43/41	42/40	45/41	48/46	50/44	60/46	62/56	66/62
Oil charge Circuit 1 / Circuit 2	(l)	6/6	6/6	6/6	6/6	7/6	7/6	7/7	8/8
POE Oil type		OIL0048E or OIL0023E							

(1) Indicative performance at Evaporator water temperature: 12°C / 7°C - Condenser air temperature 35°C - for detailed performances consult Order Write Up.

(2) Under 400V/3/50Hz.

(3) Rated Condition without Pump Package.

(4) Percent minimum load may be adjusted around 15%-20% according to operating conditions by local sales office.

(5) Electrical & system data are indicative and subject to change without notice. Please refer to unit nameplate data.

(6) Not applicable for Glycol application - see tables with Minimum Flow with Glycol.

(7) Max speed - range is 60% to 100% of max speed.

(8) Refrigerant charge may vary according to option - for instance +20% for process (digit 19=P). For real value refer to unit nameplate.

(9) Data containing information on two circuits shown as follows: ckt1/ckt2.

General Data

Table 7b – General Data RTAF 090-185 Extra Efficiency - Standard and Low Noise - R1234 ze

		RTAF	RTAF	RTAF	RTAF	RTAF	RTAF	RTAF	RTAF
		090	100	110	120	130	145	155	185
		XE SN LN	XE SN LN	XE SN LN	XE SN LN	XE SN LN	XE SN LN	XE SN LN	XE SN LN
Cooling Capacity (1)	(kW)	328	360	395	427	459	509	552	614
Unit electrical data (2) (3) (4)									
Maximum Power input in cooling	(kW)	166	180	194	205	216	247	274	278
Unit rated amps (Max compressor+fan+control)	(A)	270	293	316	337	358	405	446	452
Unit start up amps starting Amps of the larges compr+RLA of 2nd compr+RLA of all fans+control)	(A)	368	410	433	465	486	555	596	602
Displacement Power Factor (DPF)		0.89	0.89	0.89	0.88	0.87	0.88	0.89	0.89
Max power cable cross section	mm ²	1*240	1*240	1*240	1*240	1*240	2*300	2*300	2*300
Disconnect switch size	(A)	400	400	500	500	500	630	630	630
Compressor									
Quantity	#	2	2	2	2	2	2	2	2
Type		Screw	Screw	Screw	Screw	Screw	Screw	Screw	Screw
Model (9)		45/45	55/45	55/55	65/55	65/65	78/65	78/78	78/78
Max Compr Power input (Circuit 1 / Circuit 2)	kW	73/73	87/73	87/87	98/87	98/98	125/98	125/125	125/125
Max Amps Circuit1 / Circuit 2 (3) (5)	(A)	119/119	142/119	142/142	163/142	163/163	204/163	204/204	204/204
Start up Amps Circuit1 / Circuit 2 (3)(5)	(A)	217/217	259/217	259/259	291/259	291/291	354/291	354/354	354/354
Motor RPM	(rpm)	3000	3000	3000	3000	3000	3000	3000	3000
Oil sump heater Circuit1 / Circuit 2	(W)					550/550			
Evaporator									
Quantity	#	1	1	1	1	1	1	1	1
Type		Flooded shell and tube heat exchanger							
Evaporator model		115B	115A	115A	165C	165B	200C	200C	200B
Evaporator Water Content volume	(l)	51	58	58	64	74	89	89	99
Antifreeze Heater	(W)	1640	1640	1640	1640	1640	1640	1640	2040
Two pass evaporator									
Evap. Water Flow rate - Minimum (6)	(l/s)	8.0	9.4	9.4	11.1	11.6	13.0	13.0	14.2
Evap. Water Flow rate - Maximum	(l/s)	29.6	34.7	34.7	41.2	43.1	48.0	48.0	52.6
Nominal water connection size (Grooved coupling)	(in) - (mm)	4" - 100	4" - 100	4" - 100	5" - 125	5" - 125	6" - 150	6" - 150	6" - 150
Two pass evaporator with turbulator									
Evap. Water Flow rate - Minimum (6)	(l/s)	6.6	7.8	7.8	9.3	9.7	10.8	10.8	11.8
Evap. Water Flow rate - Maximum	(l/s)	26.6	31.2	31.2	37.0	38.7	43.1	43.1	47.2
Nominal water connection size (Grooved coupling)	(in) - (mm)	4" - 100	4" - 100	4" - 100	5" - 125	5" - 125	6" - 150	6" - 150	6" - 150
Hydraulic Module Components									
Standard head pressure pump option (twin pumps)									
Available Head Pressure (1)	(kPa)	129	126	111	107	136	121	160	151
Max. Motor Power	(kW)	5.5	5.5	5.5	5.5	7.5	7.5	11.0	11.0
Max Amps	(A)	11.0	11.0	11.0	11.0	14.4	14.4	20.8	20.8
High head pressure pump option (twin pumps)									
Available Head Pressure (1)	(kPa)	246	243	227	222	212	237	226	218
Max. Motor Power	(kW)	11.0	11.0	11.0	11.0	11.0	15.0	15.0	15.0
Max Amps	(A)	20.8	20.8	20.8	20.8	20.8	28.0	28.0	28.0
Expansion Tank Volume	(l)	80	80	80	80	80	80	80	80
Max User water loop Volume for factory mounted expansion tank (1)	(l)	6000	6000	6000	6000	6000	6000	6000	6000
Max. Water-side Operating Pressure without pump package	(kPa)	1000	1000	1000	1000	1000	1000	1000	1000
Max. Water-side Operating Pressure with pump package	(kPa)	450	450	450	450	450	450	450	450
Antifreeze Heater with pump package	(W)	2360	2360	2360	2360	2360	2360	2360	2760
Condenser									
Type									
Quantity	#	5/5	5/5	5/5	5/5	5/5	6/6	6/6	7/7
Face area per coil	(m ²)	2.4	2.4	2.4	2.4	2.4	2.4	2.4	2.4
Condenser Fan (nominal conditions)									
Quantity	#	5/5	5/5	5/5	5/5	5/5	6/6	6/6	7/7
Diameter	(mm)	800	800	800	800	800	800	800	800
Standard / High ambient fan option									
Fan / motor Type		Propeller fan / Fixed speed - AC motor							
Airflow per Fan	(m ³ /h)	15000	17400	17400	17400	17400	20000	20000	20000
Max Power input per Motor	(kW)	0.6	0.9	0.9	0.9	0.9	1.3	1.3	1.3
Max Amps per Motor	(A)	1.1	1.6	1.6	1.6	1.6	2.3	2.3	2.3
Motor RPM	(rpm)	710	810	810	810	810	910	910	910

General Data

Table 7b – General Data RTAF 090-185 Extra Efficiency - Standard and Low Noise - R1234 ze (continued)

		RTAF	RTAF	RTAF	RTAF	RTAF	RTAF	RTAF	RTAF
		090	100	110	120	130	145	155	185
		XE SN LN	XE SN LN	XE SN LN	XE SN LN	XE SN LN	XE SN LN	XE SN LN	XE SN LN
Low ambient fan option									
Fan / motor Type		Propeller fan / Variable speed - EC motor							
Airflow per Fan	(m ³ /h)	15000	17400	17400	17400	17400	20000	20000	20000
Max Power input per Motor	(kW)	0.6	0.9	0.9	0.9	0.9	1.3	1.3	1.3
Max Amps per Motor	(A)	1.1	1.6	1.6	1.6	1.6	2.3	2.3	2.3
Motor RPM	(rpm)	710	810	810	810	810	910	910	910
System data									
Nb of refrigerant circuit	#	2	2	2	2	2	2	2	2
Minimum cooling load % (6)	%	30	30	30	30	30	30	30	30
Standard unit									
Refrigerant charge Circuit 1 / Circuit 2	(kg)	44/42	43/41	43/41	44/45	45/43	58/48	58/48	63/49
Oil charge Circuit 1 / Circuit 2	(l)	5/5	5/5	5/5	6/5	6/6	6/6	6/6	6/6
POE Oil type (10)		OIL00317 or OIL00315							

- (1) Indicative performance at Evaporator water temperature: 12°C / 7°C - Condenser air temperature 35°C - for detailed performances consult Order Write Up.
- (2) Under 400V/3/50Hz.
- (3) Rated Condition without Pump Package.
- (4) Percent minimum load may be adjusted around 15%-20% according to operating conditions by local sales office.
- (5) Electrical & system data are indicative and subject to change without notice. Please refer to unit nameplate data.
- (6) Not applicable for Glycol application - see tables with Minimum Flow with Glycol.
- (7) Max speed - range is 60% to 100% of max speed.
- (8) Refrigerant charge may vary according to option - for instance +20% for process (digit 19 = p). For real value refer to unit nameplate.
- (9) Data containing information on two circuits shown as follows: ckt1/ckt2.
- (10) OIL0066E or OIL0067E may have been used on early orders and there is no restriction to continue to use them but preferable oil is OIL00315 or OIL00317.

General Data

Table 8a – General Data RTAF 090-245 Extra Efficiency - Extra Low Noise - R134a - R513A

		RTAF 090 XE XLN	RTAF 105 XE XLN	RTAF 125 XE XLN	RTAF 145 XE XLN	RTAF 155 XE XLN	RTAF 175 XE XLN	RTAF 190 XE XLN	RTAF 205 XE XLN	RTAF 245 XE XLN
Cooling Capacity (1)	(kW)	326	380	447	526	569	633	689	752	830
Unit electrical data (2) (3) (5)										
Maximum Power input in cooling	(kW)	141.1	162.3	190.5	222.6	245.0	267.9	294.2	317.1	317.1
Unit rated amps (Max compr +Fan+Control)	(A)	227	265	315	371	406	445	486	525	525
Unit start up amps (Starting Amps of the largest compr+RLA of 2nd compr+RLA of all fans+ control)	(A)	274	329	440	496	559	570	639	639	639
Unit Power factor		0.90	0.89	0.88	0.87	0.87	0.87	0.88	0.87	0.87
Max power cable cross section	(mm ²)	240	240	240	2*300	2*300	2*300	2*300	2*300	2*300
Disconnect switch size	(A)	400	400	500	630	630	630	800	800	800
Compressor										
Quantity	#	2	2	2	2	2	2	2	2	2
Type		Screw	Screw	Screw	Screw	Screw	Screw	Screw	Screw	Screw
Model (9)		45/45	50/50	70/50	70/70	85/70	100/70	100/85	100/100	100/100
Max Compr Power input Circuit 1/ Circuit 2	(kW)	60/60	71/71	99/71	99/99	121/99	144/99	144/121	144/144	144/144
Max Amps Circuit 1 / Circuit 2 (3) (5)	(A)	97/97	116/116	166/116	166/166	201/166	240/166	240/201	240/240	240/240
Start up Amps Circuit 1 / Circuit 2 (3) (5)	(A)	144/144	180/180	291/180	291/291	354/291	354/291	354/354	354/354	354/354
Motor RPM	(rpm)	3000	3000	3000	3000	3000	3000	3000	3000	3000
Oil sump heater Circuit 1 / Circuit 2	(W)	150/150	150/150	150/150	150/150	150/150	150/150	150/150	150/150	150/150
Evaporator										
Quantity	#	1	1	1	1	1	1	1	1	1
Type		Flooded shell and tube heat exchanger								
Evaporator model		115B	115A	165B	165B	165A	200B	200B	250B	250B
Evaporator Water Content volume	(l)	51	58	74	74	78	99	99	118	118
Antifreeze Heater	(W)	1640	1640	1640	1640	1640	2040	2040	2040	2040
Two pass evaporator										
Evap. Water Flow rate - Minimum	(l/s)	8.0	9.4	11.6	11.6	12.4	14.2	14.2	17.9	17.9
Evap. Water Flow rate - Maximum (6)	(l/s)	29.6	34.7	43.1	43.1	46.0	52.6	52.6	66.5	66.5
Nominal water connection size (Grooved coupling)	(in) - (DN)	4" - 100	4" - 100	5" - 125	5" - 125	5" - 125	6" - 150	6" - 150	6" - 150	6" - 150
Two pass evaporator with turbulator										
Evap. Water Flow rate - Minimum (6)	(l/s)	6.6	7.8	9.7	9.7	10.3	11.8	11.8	14.9	14.9
Evap. Water Flow rate - Maximum	(l/s)	26.6	31.2	38.7	38.7	41.3	47.2	47.2	59.7	59.7
Nominal water connection size (Grooved coupling)	(in) - (mm)	4" - 100	4" - 100	5" - 125	5" - 125	5" - 125	6" - 150	6" - 150	6" - 150	6" - 150
Hydraulic Module Components										
Standard head pressure pump option										
Available Head Pressure (1)	(kPa)	142	128	143	122	179	172	153	149	149
Max Motor Power input	(kW)	5.5	5.5	7.5	7.5	11.0	11.0	11.0	11.0	11.0
Max Amps	(A)	11.0	11.0	14.4	14.4	20.8	20.8	20.8	20.8	20.8
High head pressure pump option										
Available Head Pressure (1)	(kPa)	253	240	224	245	237	230	264	260	260
Max Motor Power input	(kW)	11.0	11.0	11.0	15.0	15.0	15.0	18.5	18.5	18.5
Max Amps	(A)	20.8	20.8	20.8	28.0	28.0	28.0	34.5	34.5	34.5
Expansion Tank Volume	(l)	80	80	80	80	80	80	80	80	80
Max User water loop Volume for factory mounted expansion tank (1)	(l)	6000	6000	6000	6000	6000	6000	6000	6000	6000
Max. Water-side Operating Pressure without pump package	(kPa)	1000	1000	1000	1000	1000	1000	1000	1000	1000
Max. Water-side Operating Pressure with pump package	(kPa)	450	450	450	450	450	450	450	450	450
Antifreeze Heater with pump package	(W)	2360	2360	2360	2360	2360	2760	2760	2760	2760

General Data

Table 8a – General Data RTAF 090-245 Extra Efficiency - Extra Low Noise - R134a - R513A (continued)

		RTAF 090 XE XLN	RTAF 105 XE XLN	RTAF 125 XE XLN	RTAF 145 XE XLN	RTAF 155 XE XLN	RTAF 175 XE XLN	RTAF 190 XE XLN	RTAF 205 XE XLN	RTAF 245 XE XLN
Condenser										
Type		Full aluminum Micro channel heat exchanger								
Quantity	#	5/5	5/5	5/5	6/6	6/6	7/5	7/7	7/7	7/7
Face area per coil	(m ²)	2.4	2.4	2.4	2.4	2.4	2.4	2.4	2.4	2.4
Condenser Fan										
Quantity	#	5/5	5/5	5/5	6/6	6/6	7/5	7/7	7/7	7/7
Diameter	(mm)	800	800	800	800	800	800	800	800	800
Standard / High ambient fan option										
Fan / motor Type		Propeller fan / Variable speed - EC motor								
Airflow per Fan	(m ³ /h)	15000	17400	17400	17400	17400	20000	20000	20000	20000
Max Power input per Motor	(kW)	0.5	0.8	0.8	0.8	0.8	1.1	1.1	1.1	1.1
Max Amps per Motor	(A)	0.8	1.2	1.2	1.2	1.2	1.8	1.8	1.8	1.8
Motor RPM	(rpm)	660	760	760	760	760	860	860	860	860
Low ambient fan option										
Fan / motor Type		Propeller fan / Variable speed - EC motor								
Airflow per Fan	(m ³ /h)	15000	17400	17400	17400	17400	20000	20000	20000	20000
Max Power input per Motor	(kW)	0.5	0.8	0.8	0.8	0.8	1.1	1.1	1.1	1.1
Max Amps per Motor	(A)	0.8	1.2	1.2	1.2	1.2	1.8	1.8	1.8	1.8
Motor RPM	(rpm)	660	760	760	760	760	860	860	860	860
System data (5)										
Nb of refrigerant circuit	#	2	2	2	2	2	2	2	2	2
Minimum cooling load % (4) (7)	%	30	30	30	30	30	30	30	30	30
R134a/R513A refrigerant charge Circuit 1 / Circuit 2 (8)	(kg)	43/41	42/40	45/41	48/46	50/44	60/46	62/56	66/62	66/62
Oil charge Circuit 1 / Circuit 2	(l)	6/6	6/6	6/6	6/6	7/6	7/6	7/7	8/8	8/8
POE Oil type		OIL0048E or OIL0023E								

- (1) Indicative performance at Evaporator water temperature: 12°C / 7°C- Condenser air temperature 35°C- for detailed performances consult Order Write Up.
- (2) Under 400V/3/50Hz.
- (3) Rated Condition without Pump Package.
- (4) Percent minimum load may be adjusted around 15%-20% according to operating conditions by local sales office.
- (5) Electrical & system data are indicative and subject to change without notice. Please refer to unit nameplate data.
- (6) Not applicable for Glycol application- see tables with Minimum Flow with Glycol.
- (7) Max speed- range is 60% to 100% of max speed.
- (8) Refrigerant charge may vary according to option- for instance +20% for process (digit 19=P). For real value refer to unit nameplate.
- (9) Data containing information on two circuits shown as follows: ckt1/ckt2.

General Data

Table 8b – General Data RTAF 090-185 Extra Efficiency - Extra Low Noise - R1234 ze

		RTAF 090	RTAF 100	RTAF 110	RTAF 120	RTAF 130	RTAF 145	RTAF 155	RTAF 185
		XE XLN	XE XLN	XE XLN	XE XLN	XE XLN	XE XLN	XE XLN	XE XLN
Cooling Capacity (1)	(kW)	328	359	394	426	459	508	552	614
Unit electrical data (2) (3) (4)									
Maximum Power input in cooling	(kW)	166	180	194	205	216	247	274	278
Unit rated amps (Max compressor+fan+control)	(A)	270	293	316	337	358	405	446	452
Unit start up amps starting Amps of the larges compr+RLA of 2nd compr+RLA of all fans+control)	(A)	368	410	433	465	486	555	596	602
Displacement Power Factor (DPF)		0.89	0.89	0.89	0.88	0.87	0.88	0.89	0.89
Max power cable cross section	mm ²	1*240	1*240	1*240	1*240	1*240	2*300	2*300	2*300
Disconnect switch size	(A)	400	400	500	500	500	630	630	630
Compressor									
Quantity	#	2	2	2	2	2	2	2	2
Type		Screw	Screw	Screw	Screw	Screw	Screw	Screw	Screw
Model (9)		45/45	55/45	55/55	65/55	65/65	78/65	78/78	78/78
Max Compr Power input (Circuit 1 / Circuit 2)	kW	73/73	87/73	87/87	98/87	98/98	125/98	125/125	125/125
Max Amps Circuit1 / Circuit 2 (3) (5)	(A)	119/119	142/119	142/142	163/142	163/163	204/163	204/204	204/204
Start up Amps Circuit1 / Circuit 2 (3)(5)	(A)	217/217	259/217	259/259	291/259	291/291	354/291	354/354	354/354
Motor RPM	(rpm)	3000	3000	3000	3000	3000	3000	3000	3000
Oil sump heater Circuit1 / Circuit 2	(W)					150/150			
Evaporator									
Quantity	#	1	1	1	1	1	1	1	1
Type		Flooded shell and tube heat exchanger							
Evaporator model		115B	115A	115A	165C	165B	200C	200C	200B
Evaporator Water Content volume	(l)	51	58	58	64	74	89	89	99
Antifreeze Heater	(W)	1640	1640	1640	1640	1640	1640	1640	2040
Two pass evaporator									
Evap. Water Flow rate - Minimum (6)	(l/s)	8.0	9.4	9.4	11.1	11.6	13.0	13.0	14.2
Evap. Water Flow rate - Maximum	(l/s)	29.6	34.7	34.7	41.2	43.1	48.0	48.0	52.6
Nominal water connection size (Grooved coupling)	(in) - (mm)	4" - 100	4" - 100	4" - 100	5" - 125	5" - 125	6" - 150	6" - 150	6" - 150
Two pass evaporator with turbulator									
Evap. Water Flow rate - Minimum (6)	(l/s)	6.6	7.8	7.8	9.3	9.7	10.8	10.8	11.8
Evap. Water Flow rate - Maximum	(l/s)	26.6	31.2	31.2	37.0	38.7	43.1	43.1	47.2
Nominal water connection size (Grooved coupling)	(in) - (mm)	4" - 100	4" - 100	4" - 100	5" - 125	5" - 125	6" - 150	6" - 150	6" - 150
Hydraulic Module Components									
Standard head pressure pump option (twin pumps)									
Available Head Pressure (1)	(kPa)	129	126	111	107	136	121	160	151
Max. Motor Power	(kW)	5.5	5.5	5.5	5.5	7.5	7.5	11.0	11.0
Max Amps	(A)	11.0	11.0	11.0	11.0	14.4	14.4	20.8	20.8
High head pressure pump option (twin pumps)									
Available Head Pressure (1)	(kPa)	246	243	227	222	212	237	226	218
Max. Motor Power	(kW)	11.0	11.0	11.0	11.0	11.0	15.0	15.0	15.0
Max Amps	(A)	20.8	20.8	20.8	20.8	20.8	28.0	28.0	28.0
Expansion Tank Volume	(l)	80	80	80	80	80	80	80	80
Max User water loop Volume for factory mounted expansion tank (1)	(l)	6000	6000	6000	6000	6000	6000	6000	6000
Max. Water-side Operating Pressure without pump package	(kPa)	1000	1000	1000	1000	1000	1000	1000	1000
Max. Water-side Operating Pressure with pump package	(kPa)	450	450	450	450	450	450	450	450
Antifreeze Heater with pump package	(W)	2360	2360	2360	2360	2360	2360	2360	2760
Condenser									
Type									
Quantity	#	5/5	5/5	5/5	5/5	5/5	6/6	6/6	7/7
Face area per coil	(m ²)	2.4	2.4	2.4	2.4	2.4	2.4	2.4	2.4
Condenser Fan (nominal conditions)									
Quantity	#	5/5	5/5	5/5	5/5	5/5	6/6	6/6	7/7
Diameter	(mm)	800	800	800	800	800	800	800	800
Standard / High ambient fan option									
Fan / motor Type		Propeller fan / Fixed speed - AC motor							
Airflow per Fan	(m ³ /h)	15000	17400	17400	17400	17400	20000	20000	20000
Max Power input per Motor	(kW)	0.5	0.8	0.8	0.8	0.8	1.1	1.1	1.1
Max Amps per Motor	(A)	0.8	1.2	1.2	1.2	1.2	1.8	1.8	1.8
Motor RPM	(rpm)	660	760	760	760	760	860	860	860

General Data

Table 8b – General Data RTAF 090-185 Extra Efficiency - Extra Low Noise - R1234 ze (continued)

		RTAF 090 XE XLN	RTAF 100 XE XLN	RTAF 110 XE XLN	RTAF 120 XE XLN	RTAF 130 XE XLN	RTAF 145 XE XLN	RTAF 155 XE XLN	RTAF 185 XE XLN
Low ambient fan option									
Fan / motor Type		Propeller fan / Variable speed - EC motor							
Airflow per Fan	(m ³ /h)	15000	17400	17400	17400	17400	20000	20000	20000
Max Power input per Motor	(kW)	0.5	0.8	0.8	0.8	0.8	1.1	1.1	1.1
Max Amps per Motor	(A)	0.8	1.2	1.2	1.2	1.2	1.8	1.8	1.8
Motor RPM	(rpm)	660	760	760	760	760	860	860	860
System data									
Nb of refrigerant circuit	#	2	2	2	2	2	2	2	2
Minimum cooling load % (6)	%	30	30	30	30	30	30	30	30
Refrigerant charge Circuit 1 / Circuit 2	(kg)	44/42	43/41	43/41	44/45	45/43	58/48	58/48	63/49
Oil charge Circuit 1 / Circuit 2	(l)	5/5	5/5	5/5	6/5	6/6	6/6	6/6	6/6
POE Oil type (10)		OIL00317 or OIL00315							

- (1) Indicative performance at Evaporator water temperature: 12°C / 7°C - Condenser air temperature 35°C - for detailed performances consult Order Write Up.
- (2) Under 400V/3/50Hz.
- (3) Rated Condition without Pump Package.
- (4) Percent minimum load may be adjusted around 15%-20% according to operating conditions by local sales office.
- (5) Electrical & system data are indicative and subject to change without notice. Please refer to unit nameplate data.
- (6) Not applicable for Glycol application - see tables with Minimum Flow with Glycol.
- (7) Max speed - range is 60% to 100% of max speed.
- (8) Refrigerant charge may vary according to option - for instance +20% for process (digit 19 = p). For real value refer to unit nameplate.
- (9) Data containing information on two circuits shown as follows: ckt1/ckt2.
- (10) OIL0066E or OIL0067E may have been used on early orders and there is no restriction to continue to use them but preferable oil is OIL00315 or OIL00317.

General Data

Table 9a – General data RTAF 090-245 High Seasonal Efficiency- Standard and Low Noise- R134a- R513A

		RTAF 090	RTAF 105	RTAF 125	RTAF 145	RTAF 155	RTAF 175	RTAF 190	RTAF 205	RTAF 245
		HSE SN LN	HSE SN LN	HSE SN LN	HSE SN LN	HSE SN LN	HSE SN LN	HSE SN LN	HSE SN LN	HSE SN LN
Cooling Capacity (1)	(kW)	330	383	450	530	575	637	695	747	869
Unit electrical data (2) (3) (4)										
Maximum Power input in cooling	(kW)	143.5	165.1	193.9	226.6	249.5	272.8	299.6	322.9	339.0
Unit rated amps (Max compr +Fan+Control)	(A)	220	253	296	346	381	416	457	493	517
Unit start up amps (Starting Amps of the largest compr+RLA of 2nd compr+RLA of all fans+ control)	(A)	220	253	296	346	381	416	457	493	517
Unit Power factor		0.95	0.95	0.95	0.95	0.95	0.95	0.95	0.95	0.95
Max power cable cross section	(mm ²)	240	240	240	2*300	2*300	2*300	2*300	2*300	2*300
Disconnect switch size	(A)	400	400	500	630	630	630	800	800	800
Compressor										
Quantity	#	2	2	2	2	2	2	2	2	2
Type		Screw	Screw	Screw	Screw	Screw	Screw	Screw	Screw	Screw
Model (8)		45/45	50/50	70/50	70/70	85/70	100/70	100/85	100/100	120/120
Max Compr Power input Circuit 1/Circuit 2	kW	61/61	72/72	101/72	101/101	124/101	147/101	147/124	147/147	156/156
Max Amps Circuit 1 / Circuit 2 (3) (4)	(A)	93/93	110/110	153/110	153/153	188/153	224/153	224/188	224/224	236/236
Start up Amps Circuit 1 / Circuit 2 (3) (4)	(A)	93/93	110/110	153/110	153/153	188/153	224/153	224/188	224/224	236/236
Motor RPM	(rpm)	3000	3000	3000	3000	3000	3000	3000	3000	3000
Oil sump heater Circuit 1 / Circuit 2	(W)	150/150	150/150	150/150	150/150	150/150	150/150	150/150	150/150	150/150
Evaporator										
Quantity	#	1	1	1	1	1	1	1	1	1
Type		Flooded shell and tube heat exchanger								
Evaporator model		115B	115A	165B	165B	165A	200B	200B	250B	250B
Evaporator Water Content volume	(l)	51	58	74	74	78	99	99	118	118
Antifreeze Heater	(W)	1640	1640	1640	1640	1640	2040	2040	2040	2040
Two pass evaporator										
Evap. Water Flow rate - Minimum	(l/s)	8.0	9.4	11.6	11.6	12.4	14.2	14.2	17.9	17.9
Evap. Water Flow rate - Maximum (5)	(l/s)	29.6	34.7	43.1	43.1	46.0	52.6	52.6	66.5	66.5
Nominal water connection size (Grooved coupling)	(in) - (DN)	4" - 100	4" - 100	5" - 125	5" - 125	5" - 125	6" - 150	6" - 150	6" - 150	6" - 150
Two pass evaporator with turbulator										
Evap. Water Flow rate - Minimum (5)	(l/s)	6.6	7.8	9.7	9.7	10.3	11.8	11.8	14.9	14.9
Evap. Water Flow rate - Maximum	(l/s)	26.6	31.2	38.7	38.7	41.3	47.2	47.2	59.7	59.7
Nominal water connection size (Grooved coupling)	(in) - (mm)	4" - 100	4" - 100	5" - 125	5" - 125	5" - 125	6" - 150	6" - 150	6" - 150	6" - 150
Hydraulic Module Components										
Standard head pressure pump option										
Available Head Pressure (1)	(kPa)	141	128	142	121	179	172	153	149	149
Max Motor Power input	(kW)	4.9	5.1	6.5	6.9	9.3	9.6	9.8	10.0	10.0
Max Amps	(A)	5.5	5.5	7.5	7.5	11.0	11.0	11.0	11.0	11.0
High head pressure pump option										
Available Head Pressure (1)	(kPa)	253	239	224	245	237	230	264	260	260
Max Motor Power input	(kW)	11.0	11.0	11.0	15.0	15.0	15.0	18.5	18.5	18.5
Max Amps	(A)	20.8	20.8	20.8	28.0	28.0	28.0	34.5	34.5	34.5
Expansion Tank Volume	(l)	80	80	80	80	80	80	80	80	80
Max User water loop Volume for factory mounted expansion tank (1)	(l)	6000	6000	6000	6000	6000	6000	6000	6000	6000
Max. Water-side Operating Pressure without pump package	(kPa)	1000	1000	1000	1000	1000	1000	1000	1000	1000
Max. Water-side Operating Pressure with pump package	(kPa)	450	450	450	450	450	450	450	450	450
Antifreeze Heater with pump package	(W)	2360	2360	2360	2360	2360	2760	2760	2760	2760
Condenser										
Type		Full aluminum Micro channel heat exchanger								
Quantity	#	5/5	5/5	5/5	6/6	6/6	7/5	7/7	7/7	7/7
Face area per coil	(m ²)	2.4	2.4	2.4	2.4	2.4	2.4	2.4	2.4	2.4
Condenser Fan										
Quantity	#	5/5	5/5	5/5	6/6	6/6	7/5	7/7	7/7	7/7
Diameter	(mm)	800	800	800	800	800	800	800	800	800
Standard / High ambient fan option										
Fan / motor Type		Propeller fan / Variable speed - EC motor								
Airflow per Fan	(m ³ /h)	15000	17400	17400	17400	17400	20000	20000	20000	20000
Max Power input per Motor	(kW)	0.6	0.9	0.9	0.9	0.9	1.3	1.3	1.3	1.3

General Data

Table 9a – General data RTAF 090-245 High Seasonal Efficiency - Standard and Low Noise - R134a - R513A (continued)

		RTAF 090	RTAF 105	RTAF 125	RTAF 145	RTAF 155	RTAF 175	RTAF 190	RTAF 205	RTAF 245
		HSE SN LN	HSE SN LN	HSE SN LN	HSE SN LN	HSE SN LN	HSE SN LN	HSE SN LN	HSE SN LN	HSE SN LN
Max Amps per Motor	(A)	1.1	1.6	1.6	1.6	1.6	2.3	2.3	2.3	2.3
Motor RPM	(rpm)	710	810	810	810	810	910	910	910	910
Low ambient fan option										
Fan / motor Type		Propeller fan / Variable speed - EC motor								
Airflow per Fan	(m ³ /h)	15000	17400	17400	17400	17400	20000	20000	20000	20000
Max Power input per Motor	(kW)	0.6	0.9	0.9	0.9	0.9	1.3	1.3	1.3	1.3
Max Amps per Motor	(A)	1.1	1.6	1.6	1.6	1.6	2.3	2.3	2.3	2.3
Motor RPM	(rpm)	710	810	810	810	810	910	910	910	910
System data (4)										
Nb of refrigerant circuit	#	2	2	2	2	2	2	2	2	2
Minimum cooling load % (6)	%	15	15	15	15	15	15	15	15	15
R134a/R513A refrigerant charge Circuit 1 / Circuit 2 (7)	(kg)	43/41	42/40	45/41	48/46	50/44	60/46	62/56	66/62	66/62
Oil charge Circuit 1 / Circuit 2	(l)	5/5	5/5	5/5	6/5	6/6	6/6	6/6	6/6	7/7
POE Oil type		OIL00317 or OIL00311								

- (1) Indicative performance at Evaporator water temperature: 12°C / 7°C - Condenser air temperature 35°C - for detailed performances consult Order Write Up.
- (2) Under 400V/3/50Hz.
- (3) Rated Condition without Pump Package.
- (4) Electrical & system data are indicative and subject to change without notice. Please refer to unit nameplate data.
- (5) Not applicable for Glycol application - see tables with Minimum Flow with Glycol.
- (6) Max speed - range is 60% to 100% of max speed.
- (7) Refrigerant charge may vary according to option - for instance +20% for process (digit 19=P). For real value refer to unit nameplate.
- (8) Data containing information on two circuits shown as follows: ckt1/ckt2.

General Data

Table 9b – General data RTAF 090-225 & 101 High Seasonal Efficiency- Standard and Low Noise - R1234 ze

		RTAF 090	RTAF 100	RTAF 110	RTAF 120	RTAF 130	RTAF 145	RTAF 155	RTAF 185	RTAF 200	RTAF 225	RTAF 101 (10)
		HSE LN SN	HSE LN SN	HSE LN SN	HSE LN SN	HSE LN SN	HSE LN SN	HSE LN SN	HSE LN SN	HSE LN SN	HSE LN SN	HSE LN SN
Cooling Capacity (1)	(kW)	326	358	394	426	460	510	554	614	725	841	781
Unit electrical data (2) (3) (4)												
Maximum Power input in cooling	(kW)	169	184	198	222	245	270	292	296	338	385	378
Unit amps (4) (5)												
Unit rated amps (Max compressor+fan+control)	(A)	259	281	302	338	374	412	445	451	516	587	575
Unit start up amps starting Amps of the largest compr+RLA of 2nd compr+RLA of all fans+control)	(A)	259	281	302	338	374	412	445	451	516	587	575
Displacement Power Factor (DPF)	mm ²	0.95	0.95	0.95	0.95	0.95	0.95	0.95	0.95	0.95	0.95	0.95
Max power cable cross section		1*240	1*240	1*240	1*240	1*240	2*300	2*300	2*300	2*300	2*300	2*300
Disconnect switch size	(A)	400	400	500	500	500	630	630	630	800	800	800
Compressor												
Quantity	#	2	2	2	2	2	2	2	2	2	2	2
Type		Screw	Screw	Screw	Screw	Screw	Screw	Screw	Screw	Screw	Screw	Screw
Model (8)		74/74	89/74	89/89	112/89	112/112	134/112	134/134	134/134	155/155	179/179	179/179
Max Compr Power input Circuit 1 / Circuit 2	kW	45/45	55/45	55/55	65/55	65/65	78/65	78/78	78/78	78/78	78/78	78/78
Max Amps Circuit 1 / Circuit 2 (3) (4)	(A)	113/113	135/113	135/135	171/135	171/171	203/171	203/203	203/203	236/236	271/271	271/271
Start up Amps Circuit1 / Circuit 2 (3)(4)	(A)	113/113	135/113	135/135	171/135	171/171	203/171	203/203	203/203	236/236	271/271	271/271
Motor RPM	(rpm)	3000	3000	3000	3000	3000	3000	3000	3000	3600	4200	4200
Oil sump heater Circuit 1 / Circuit 2	(W)						150/150					
Evaporator												
Quantity	#	1	1	1	1	1	1	1	1	1	1	1
Type		Flooded shell and tube heat exchanger										
Evaporator model		115B	115A	115A	165C	165B	200C	200C	200B	250B	250B	165B
Evaporator Water Content volume	(l)	51	58	58	64	74	89	89	99	118	118	74
Antifreeze Heater	(W)	1640	1640	1640	1640	1640	1640	1640	2040	2040	2040	1640
Evap. Water Flow rate - Minimum (6)												
Evap. Water Flow rate - Maximum	(l/s)	8.0	9.4	9.4	11.1	11.6	13.0	13.0	14.2	17.9	17.9	11.6
Evap. Water Flow rate - Maximum	(l/s)	29.6	34.7	34.7	41.2	43.1	48.0	48.0	52.6	66.5	66.5	43.1
Nominal water connection size (Grooved coupling)	(in) - (mm)	4" - 100	4" - 100	4" - 100	5" - 125	5" - 125	6" - 150	6" - 150	6" - 150	6" - 150	6" - 150	5" - 125
Evap. Water Flow rate - Minimum (6)												
Evap. Water Flow rate - Minimum	(l/s)	6.6	7.8	7.8	9.3	9.7	10.8	10.8	11.8	14.9	14.9	9.7
Evap. Water Flow rate - Maximum	(l/s)	26.6	31.2	31.2	37.0	38.7	43.1	43.1	47.2	59.7	59.7	38.7
Nominal water connection size (Grooved coupling)	(in) - (mm)	4" - 100	4" - 100	4" - 100	5" - 125	5" - 125	6" - 150	6" - 150	6" - 150	6" - 150	6" - 150	5" - 125
Hydraulic Module Components												
Standard head pressure pump option (twin pumps)												
Standard head pressure pump option												
Available Head Pressure (1)	(kPa)	129	126	111	107	136	121	160	151	131	89	93
Max Amps	(kW)	5.5	5.5	5.5	5.5	7.5	7.5	11.0	11.0	11.0	11.0	11.0
High head pressure pump option (twin pumps)	(A)	11.0	11.0	11.0	11.0	14.4	14.4	20.8	20.8	20.8	20.8	20.8
High head pressure pump option												
Available Head Pressure (1)	(kPa)	246	243	227	222	212	237	226	218	244	197	209
Max Amps	(kW)	11.0	11.0	11.0	11.0	11.0	15.0	15.0	15.0	18.5	18.5	18.5
Max. Rated Amps	(A)	20.8	20.8	20.8	20.8	20.8	28.0	28.0	28.0	34.5	34.5	34.5
Expansion Tank Volume	(l)	80	80	80	80	80	80	80	80	80	80	80
Max User water loop Volume for factory mounted expansion tank (1)	(l)	6000	6000	6000	6000	6000	6000	6000	6000	6000	6000	6000
Max. Water-side Operating Pressure without pump package	(kPa)	1000	1000	1000	1000	1000	1000	1000	1000	1000	1000	1000
Max. Water-side Operating Pressure with pump package	(kPa)	450	450	450	450	450	450	450	450	450	450	450
Antifreeze Heater with pump package	(W)	2360	2360	2360	2360	2360	2360	2360	2760	2760	2760	2360
Condenser												
Type												
Quantity	#	5/5	5/5	5/5	5/5	5/5	6/6	6/6	7/7	7/7	7/7	5/5
Face area per coil	(m ²)	2.4	2.4	2.4	2.4	2.4	2.4	2.4	2.4	2.4	2.4	2.4
Condenser Fan (nominal conditions)												
Quantity	#	4/4	5/5	5/5	5/5	5/5	6/6	6/6	7/7	7/7	7/7	5/5
Diameter	(mm)	800	800	800	800	800	800	800	800	800	800	800

General Data

Table 9b – General data RTAF 090-225 & 101 High Seasonal Efficiency - Standard and Low Noise - R1234 ze (continued)

	RTAF 090	RTAF 100	RTAF 110	RTAF 120	RTAF 130	RTAF 145	RTAF 155	RTAF 185	RTAF 200	RTAF 225	RTAF 101 (10)	
	HSE SN LN	HSE SN LN	HSE SN LN	HSE SN LN	HSE SN LN	HSE SN LN	HSE SN LN	HSE SN LN	HSE SN LN	HSE SN LN	HSE SN LN	
Standard / High ambient fan option												
Fan / motor Type	Propeller fan / Variable speed - EC motor											
Airflow per Fan	(m ³ /h)	15000	17400	17400	17400	17400	20000	20000	20000	20000	20000	17400
Max Power input per Motor	(kW)	0.6	0.9	0.9	0.9	0.9	1.3	1.3	1.3	1.3	1.3	0.9
Max Amps per Motor	(A)	1.1	1.6	1.6	1.6	1.6	2.3	2.3	2.3	2.3	2.3	1.6
Motor RPM	(rpm)	710	810	810	810	810	910	910	910	910	910	810
Low ambient fan option												
Fan / motor Type	Propeller fan / Variable speed - EC motor											
Airflow per Fan	(m ³ /h)	15000	17400	17400	17400	17400	20000	20000	20000	20000	20000	17400
Max Power input per Motor	(kW)	0.6	0.9	0.9	0.9	0.9	1.3	1.3	1.3	1.3	1.3	0.9
Max Amps per Motor	(A)	1.1	1.6	1.6	1.6	1.6	2.3	2.3	2.3	2.3	2.3	1.6
Motor RPM	(rpm)	710	710	810	810	810	810	810	910	910	910	910
System data												
Nb of refrigerant circuit	#	2	2	2	2	2	2	2	2	2	2	2
Minimum cooling load % (6)	%	30	30	30	30	30	30	30	30	30	30	30
Refrigerant charge Circuit 1 / Circuit 2	(kg)	44/42	43/41	43/41	44/45	45/43	58/48	58/48	63/49	66/62	66/62	TBD
Oil charge Circuit 1 / Circuit 2	(l)	5/5	5/5	5/5	6/5	6/6	6/6	6/6	6/6	7/7	7/7	6/6
POE Oil type (11)		OIL00317 or OIL00315										

(1) Indicative performance at Evaporator water temperature: 12°C / 7°C - Condenser air temperature 35°C - for detailed performances consult Order Write Up.

(2) Under 400V/3/50Hz.

(3) Rated Condition without Pump Package.

(4) Percent minimum load may be adjusted around 15%-20% according to operating conditions by local sales office.

(5) Electrical & system data are indicative and subject to change without notice. Please refer to unit nameplate data.

(6) Not applicable for Glycol application - see tables with Minimum Flow with Glycol.

(7) Max speed - range is 60% to 100% of max speed.

(8) Refrigerant charge may vary according to option - for instance +20% for process (digit 19 = p). For real value refer to unit nameplate.

(9) Data containing information on two circuits shown as follows: ckt1/ckt2.

(10) Not suitable for comfort application - data are indicative - consult Order Write Up.

(11) OIL0066E or OIL0067E may have been used on early orders and there is no restriction to continue to use them but preferable oil is OIL00315 or OIL00317.

General Data

Table 10a – General data RTAF 090-245 High Seasonal Efficiency- Extra Low Noise- R134a- R513A

		RTAF 090	RTAF 105	RTAF 125	RTAF 145	RTAF 155	RTAF 175	RTAF 190	RTAF 205	RTAF 245
		HSE XLN	HSE XLN	HSE XLN	HSE XLN	HSE XLN	HSE XLN	HSE XLN	HSE XLN	HSE XLN
Cooling Capacity (1)	(kW)	330	383	451	533	575	638	694	755	875
Unit electrical data (2) (3) (4)										
Maximum Power input in cooling	(kW)	143.5	165.1	193.9	226.6	249.5	272.8	299.6	322.9	339.0
Unit rated amps (Max compr +Fan+Control)	(A)	220	253	296	346	381	416	457	493	517
Unit start up amps (Starting Amps of the largest compr+RLA of 2nd compr+RLA of all fans+ control)	(A)	220	253	296	346	381	416	457	493	517
Unit Power factor		0.95	0.95	0.95	0.95	0.95	0.95	0.95	0.95	0.95
Max power cable cross section	(mm ²)	240	240	240	2*300	2*300	2*300	2*300	2*300	2*300
Disconnect switch size	(A)	400	400	500	630	630	630	800	800	800
Compressor										
Quantity	#	2	2	2	2	2	2	2	2	2
Type		Screw	Screw	Screw	Screw	Screw	Screw	Screw	Screw	Screw
Model (8)		45/45	50/50	70/50	70/70	85/70	100/70	100/85	100/100	120/120
Max Compr Power input Circuit 1/Circuit 2	kW	61/61	72/72	101/72	101/101	124/101	147/101	147/124	147/147	156/156
Max Amps Circuit 1 / Circuit 2 (3) (4)	(A)	93/93	110/110	153/110	153/153	188/153	224/153	224/188	224/224	236/236
Start up Amps Circuit 1 / Circuit 2 (3) (4)	(A)	93/93	110/110	153/110	153/153	188/153	224/153	224/188	224/224	236/236
Motor RPM	(rpm)	3000	3000	3000	3000	3000	3000	3000	3000	3000
Oil sump heater Circuit 1 / Circuit 2	(W)	150/150	150/150	150/150	150/150	150/150	150/150	150/150	150/150	150/150
Evaporator										
Quantity	#	1	1	1	1	1	1	1	1	1
Type		Flooded shell and tube heat exchanger								
Evaporator model		115B	115A	165B	165B	165A	200B	200B	250B	250B
Evaporator Water Content volume	(l)	51	58	74	74	78	99	99	118	118
Antifreeze Heater	(W)	1640	1640	1640	1640	1640	2040	2040	2040	2040
Two pass evaporator										
Evap. Water Flow rate - Minimum	(l/s)	8.0	9.4	11.6	11.6	12.4	14.2	14.2	17.9	17.9
Evap. Water Flow rate - Maximum (5)	(l/s)	29.6	34.7	43.1	43.1	46.0	52.6	52.6	66.5	66.5
Nominal water connection size (Grooved coupling)	(in) - (DN)	4" - 100	4" - 100	5" - 125	5" - 125	5" - 125	6" - 150	6" - 150	6" - 150	6" - 150
Two pass evaporator with turbulator										
Evap. Water Flow rate - Minimum (5)	(l/s)	6.6	7.8	9.7	9.7	10.3	11.8	11.8	14.9	14.9
Evap. Water Flow rate - Maximum	(l/s)	26.6	31.2	38.7	38.7	41.3	47.2	47.2	59.7	59.7
Nominal water connection size (Grooved coupling)	(in) - (mm)	4" - 100	4" - 100	5" - 125	5" - 125	5" - 125	6" - 150	6" - 150	6" - 150	6" - 150
Hydraulic Module Components										
Standard head pressure pump option										
Available Head Pressure (1)	(kPa)	142	128	143	122	179	172	153	149	149
Max Motor Power input	(kW)	5.5	5.5	7.5	7.5	11.0	11.0	11.0	11.0	11.0
Max Amps	(A)	11.0	11.0	14.4	14.4	20.8	20.8	20.8	20.8	20.8
High head pressure pump option										
Available Head Pressure (1)	(kPa)	253	240	224	245	237	230	264	260	260
Max Motor Power input	(kW)	11.0	11.0	11.0	15.0	15.0	15.0	18.5	18.5	18.5
Max Amps	(A)	20.8	20.8	20.8	28.0	28.0	28.0	34.5	34.5	34.5
Expansion Tank Volume	(l)	80	80	80	80	80	80	80	80	80
Max User water loop Volume for factory mounted expansion tank (1)	(l)	6000	6000	6000	6000	6000	6000	6000	6000	6000
Max. Water-side Operating Pressure without pump package	(kPa)	1000	1000	1000	1000	1000	1000	1000	1000	1000
Max. Water-side Operating Pressure with pump package	(kPa)	450	450	450	450	450	450	450	450	450
Antifreeze Heater with pump package	(W)	2360	2360	2360	2360	2360	2760	2760	2760	2760
Condenser										
Type		Full aluminum Micro channel heat exchanger								
Quantity	#	5/5	5/5	5/5	6/6	6/6	7/5	7/7	7/7	7/7
Face area per coil	(m ²)	2.4	2.4	2.4	2.4	2.4	2.4	2.4	2.4	2.4
Condenser Fan										
Quantity	#	5/5	5/5	5/5	6/6	6/6	7/5	7/7	7/7	7/7
Diameter	(mm)	800	800	800	800	800	800	800	800	800
Standard / High ambient fan option										
Fan / motor Type		Propeller fan / Variable speed - EC motor								
Airflow per Fan	(m ³ /h)	15000	17400	17400	17400	17400	20000	20000	20000	20000
Max Power input per Motor	(kW)	0.5	0.8	0.8	0.8	0.8	1.1	1.1	1.1	1.1
Max Amps per Motor	(A)	0.8	1.2	1.2	1.2	1.2	1.8	1.8	1.8	1.8

General Data

Table 10a – General data RTAF 090-245 High Seasonal Efficiency - Extra Low Noise - R134a - R513A (continued)

		RTAF 090	RTAF 105	RTAF 125	RTAF 145	RTAF 155	RTAF 175	RTAF 190	RTAF 205	RTAF 245
		HSE XLN	HSE XLN	HSE XLN	HSE XLN	HSE XLN	HSE XLN	HSE XLN	HSE XLN	HSE XLN
Motor RPM	(rpm)	660	760	760	760	760	860	860	860	860
Low ambient fan option										
Fan / motor Type		Propeller fan / Variable speed - EC motor								
Airflow per Fan	(m ³ /h)	15000	17400	17400	17400	17400	20000	20000	20000	20000
Max Power input per Motor	(kW)	0.5	0.8	0.8	0.8	0.8	1.1	1.1	1.1	1.1
Max Amps per Motor	(A)	0.8	1.2	1.2	1.2	1.2	1.8	1.8	1.8	1.8
Motor RPM	(rpm)	660	760	760	760	760	860	860	860	860
System data (4)										
Nb of refrigerant circuit	#	2	2	2	2	2	2	2	2	2
Minimum cooling load % (6)	%	15	15	15	15	15	15	15	15	15
R134a/R513A refrigerant charge Circuit 1 / Circuit 2 (7)	(kg)	43/41	42/40	45/41	48/46	50/44	60/46	62/56	66/62	66/62
Oil charge Circuit 1 / Circuit 2	(l)	6/6	6/6	6/6	6/6	7/6	7/6	7/7	8/8	8/8
POE Oil type		OIL00317 or OIL00311								

(1) Indicative performance at Evaporator water temperature: 12°C / 7°C - Condenser air temperature 35°C - for detailed performances consult Order Write Up.

(2) Under 400V/3/50Hz.

(3) Rated Condition without Pump Package.

(4) Electrical & system data are indicative and subject to change without notice. Please refer to unit nameplate data.

(5) Not applicable for Glycol application - see tables with Minimum Flow with Glycol.

(6) Max speed - range is 60% to 100% of max speed.

(7) Refrigerant charge may vary according to option - for instance +20% for process (digit 19=P). For real value refer to unit nameplate.

(8) Data containing information on two circuits shown as follows: ckt1/ckt2.

General Data

Table 10b – General data RTAF 090-225 & 101 High Seasonal Efficiency - Extra Low Noise - R1234 ze

		RTAF 090	RTAF 100	RTAF 110	RTAF 120	RTAF 130	RTAF 145	RTAF 155	RTAF 185	RTAF 200	RTAF 225	RTAF 101 (10)
		HSE XLN	HSE XLN	HSE XLN	HSE XLN	HSE XLN	HSE XLN	HSE XLN	HSE XLN	HSE XLN	HSE XLN	HSE XLN
Cooling Capacity (1)	(kW)	326	357	393	426	460	510	554	614	725	841	781
Unit electrical data (2) (3) (4)												
Maximum Power input in cooling	(kW)	169	184	198	222	245	270	292	296	338	385	378
Unit rated amps (Max compressor+fan+control)	(A)	259	281	302	338	374	412	445	451	516	587	575
Unit start up amps starting Amps of the largest compr+RLA of 2nd compr+RLA of all fans+control)	(A)	259	281	302	338	374	412	445	451	516	587	575
Displacement Power Factor (DPF)		0.95	0.95	0.95	0.95	0.95	0.95	0.95	0.95	0.95	0.95	0.95
Max power cable cross section	mm ²	1*240	1*240	1*240	1*240	1*240	2*300	2*300	2*300	2*300	2*300	2*300
Disconnect switch size	(A)	400	400	500	500	500	630	630	630	800	800	800
Compressor												
Quantity	#	2	2	2	2	2	2	2	2	2	2	2
Type		Screw	Screw	Screw	Screw	Screw	Screw	Screw	Screw	Screw	Screw	Screw
Model (9)		45/45	55/45	55/55	65/55	65/65	78/65	78/78	78/78	78/78	78/78	78/78
Max Compr Power input (Circuit 1 / Circuit 2)	kW	74/74	89/74	89/89	112/89	112/112	134/112	134/134	134/134	155/155	179/179	179/179
Max Amps Circuit1 / Circuit 2 (3) (5)	(A)	113/113	135/113	135/135	171/135	171/171	203/171	203/203	203/203	236/236	271/271	271/271
Start up Amps Circuit1 / Circuit 2 (3)(5)	(A)	113/113	135/113	135/135	171/135	171/171	203/171	203/203	203/203	236/236	271/271	271/271
Motor RPM	(rpm)	3000	3000	3000	3000	3000	3000	3000	3000	3600	4200	4200
Oil sump heater Circuit1 / Circuit 2	(W)						150/150					
Evaporator												
Quantity	#	1	1	1	1	1	1	1	1	1	1	1
Type		Flooded shell and tube heat exchanger										
Evaporator model		115B	115A	115A	165C	165B	200C	200C	200B	250B	250B	165B
Evaporator Water Content volume	(l)	51	58	58	64	74	89	89	99	118	118	74
Antifreeze Heater	(W)	1640	1640	1640	1640	1640	1640	1640	2040	2040	2040	1640
Two pass evaporator												
Evap. Water Flow rate - Minimum (6)	(l/s)	8.0	9.4	9.4	11.1	11.6	13.0	13.0	14.2	17.9	17.9	11.6
Evap. Water Flow rate - Maximum	(l/s)	29.6	34.7	34.7	41.2	43.1	48.0	48.0	52.6	66.5	66.5	43.1
Nominal water connection size (Grooved coupling)	(in) - (mm)	4" - 100	4" - 100	4" - 100	5" - 125	5" - 125	6" - 150	6" - 150	6" - 150	6" - 150	6" - 150	5" - 125
Two pass evaporator with turbulator												
Evap. Water Flow rate - Minimum (6)	(l/s)	6.6	7.8	7.8	9.3	9.7	10.8	10.8	11.8	14.9	14.9	9.7
Evap. Water Flow rate - Maximum	(l/s)	26.6	31.2	31.2	37.0	38.7	43.1	43.1	47.2	59.7	59.7	38.7
Nominal water connection size (Grooved coupling)	(in) - (mm)	4" - 100	4" - 100	4" - 100	5" - 125	5" - 125	6" - 150	6" - 150	6" - 150	6" - 150	6" - 150	5" - 125
Hydraulic Module Components												
Standard head pressure pump option (twin pumps)												
Available Head Pressure (1)	(kPa)	126	111	107	136	121	160	151	131	89	93	N/A
Max. Motor Power	(kW)	5.5	5.5	5.5	5.5	7.5	7.5	11.0	11.0	11.0	11.0	11.0
Max Amps	(A)	11.0	11.0	11.0	11.0	14.4	14.4	20.8	20.8	20.8	20.8	20.8
High head pressure pump option (twin pumps)												
Available Head Pressure (1)	(kPa)	246	243	227	222	212	237	226	218	244	197	209
Max. Motor Power	(kW)	11.0	11.0	11.0	11.0	11.0	15.0	15.0	15.0	18.5	18.5	18.5
Max Amps	(A)	20.8	20.8	20.8	20.8	20.8	28.0	28.0	28.0	34.5	34.5	34.5
Expansion Tank Volume	(l)	80	80	80	80	80	80	80	80	80	80	80
Max User water loop Volume for factory mounted expansion tank (1)	(l)	6000	6000	6000	6000	6000	6000	6000	6000	6000	6000	6000
Max. Water-side Operating Pressure without pump package	(kPa)	1000	1000	1000	1000	1000	1000	1000	1000	1000	1000	1000
Max. Water-side Operating Pressure with pump package	(kPa)	450	450	450	450	450	450	450	450	450	450	450
Antifreeze Heater with pump package	(W)	2360	2360	2360	2360	2360	2360	2360	2760	2760	2760	2360
Condenser												
Type												
Quantity	#	5/5	5/5	5/5	5/5	5/5	6/6	6/6	7/7	7/7	7/7	5/5
Face area per coil	(m ²)	2.4	2.4	2.4	2.4	2.4	2.4	2.4	2.4	2.4	2.4	2.4
Condenser Fan (nominal conditions)												
Quantity	#	5/5	5/5	5/5	5/5	5/5	6/6	6/6	7/7	7/7	7/7	5/5
Diameter	(mm)	800	800	800	800	800	800	800	800	800	800	800

General Data

Table 10b – General data RTAF 090-225 & 101 High Seasonal Efficiency- Extra Low Noise- R1234 ze (continued)

		RTAF 090	RTAF 100	RTAF 110	RTAF 120	RTAF 130	RTAF 145	RTAF 155	RTAF 185	RTAF 200	RTAF 225	RTAF 101 (10)
		HSE XLN HSE XLN HSE XLN HSE XLN HSE XLN HSE XLN HSE XLN HSE XLN HSE XLN HSE XLN HSE XLN HSE XLN										
Standard / High ambient fan option												
Fan / motor Type		Propeller fan / Variable speed - EC motor										
Airflow per Fan	(m ³ /h)	15000	17400	17400	17400	17400	17400	17400	20000	20000	20000	20000
Max Power input per Motor	(kW)	0.5	0.8	0.8	0.8	0.8	0.8	0.8	1.1	1.1	1.1	1.1
Max Amps per Motor	(A)	0.8	1.2	1.2	1.2	1.2	1.2	1.2	1.8	1.8	1.8	1.8
Motor RPM	(rpm)	660	760	760	760	760	760	760	860	860	860	860
Low ambient fan option												
Fan / motor Type		Propeller fan / Variable speed - EC motor										
Airflow per Fan	(m ³ /h)	15000	17400	17400	17400	17400	17400	17400	20000	20000	20000	20000
Max Power input per Motor	(kW)	0.5	0.8	0.8	0.8	0.8	0.8	0.8	1.1	1.1	1.1	1.1
Max Amps per Motor	(A)	0.8	1.2	1.2	1.2	1.2	1.2	1.2	1.8	1.8	1.8	1.8
Motor RPM	(rpm)	660	760	760	760	760	760	760	860	860	860	860
System data												
Nb of refrigerant circuit	#	2	2	2	2	2	2	2	2	2	2	2
Minimum cooling load % (6)	%	30	30	30	30	30	30	30	30	30	30	30
Refrigerant charge Circuit 1 / Circuit 2 (8)	(kg)	44/42	43/41	43/41	44/45	45/43	58/48	58/48	63/49	66/62	66/62	43/43
Oil charge Circuit 1 / Circuit 2	(l)	5/5	5/5	5/5	6/5	6/6	6/6	6/6	6/6	7/7	7/7	6/6
POE Oil type (11)		OIL00317 or OIL00315										

- (1) Indicative performance at Evaporator water temperature: 12°C / 7°C - Condenser air temperature 35°C- for detailed performances consult Order Write Up.
- (2) Under 400V/3/50Hz.
- (3) Rated Condition without Pump Package.
- (4) Percent minimum load may be adjusted around 15%-20% according to operating conditions by local sales office.
- (5) Electrical & system data are indicative and subject to change without notice. Please refer to unit nameplate data.
- (6) Not applicable for Glycol application- see tables with Minimum Flow with Glycol.
- (7) Max speed- range is 60% to 100% of max speed.
- (8) Refrigerant charge may vary according to option- for instance +20% for process (digit 19 = p). For real value refer to unit nameplate.
- (9) Data containing information on two circuits shown as follows: ckt1/ckt2.
- (10) Not suitable for comfort application- data are indicative- consult Order Write Up.
- (11) OIL0066E or OIL0067E may have been used on early orders and there is no restriction to continue to use them but preferable oil is OIL00315 or OIL00317.

General Data

Table 11a – General Data RTAF 090-245 High Seasonal Efficiency Short - Standard and Low Noise - R134a - R513A

		RTAF 090	RTAF 105	RTAF 125	RTAF 140	RTAF 145	RTAF 150	RTAF 155	RTAF 170	RTAF 175	RTAF 185	RTAF 190	RTAF 200	RTAF 205	RTAF 245 (9)
		HSS SN LN	HSS SN LN	HSS SN LN	HSS SN LN	HSS SN LN	HSS SN LN	HSS SN LN	HSS SN LN	HSS SN LN	HSS SN LN	HSS SN LN	HSS SN LN	HSS SN LN	HSS SN LN
Cooling Capacity (1)	(kW)	330	378	443	509	526	545	567	582	617	656	676	706	731	839
Unit electrical data (2) (3) (4)															
Maximum Power input in cooling	(kW)	140	161	190	219	223	242	246	265	269	292	296	315	319	339
Unit rated amps (Max compr + Fan+Control)	(A)	214	247	290	334	340	369	375	404	410	445	451	481	487	516
Unit start up amps (Starting Amps of the largest compr+RLA of 2nd compr+RLA of all fans+ control)	(A)	214	247	290	334	340	369	375	404	410	445	451	481	487	516
Displacement Power Factor (DPF)		0.95	0.95	0.95	0.95	0.95	0.95	0.95	0.95	0.95	0.95	0.95	0.95	0.95	0.95
Max power cable cross section	(mm ²)	1x240	1x240	1x240	2x300	2x300	2x300	2x300	2x300	2x300	2x300	2x300	2x300	2x300	2x300
Disconnect switch size	(A)	400	400	500	630	630	630	630	630	630	800	800	800	800	800
Compressor															
Quantity	#	2	2	2	2	2	2	2	2	2	2	2	2	2	2
Type		Screw	Screw	Screw	Screw	Screw	Screw	Screw	Screw	Screw	Screw	Screw	Screw	Screw	Screw
Model (9)		45/45	50/50	70/50	70/70	70/70	85/70	85/70	85/85	100/70	100/85	100/85	100/100	100/100	120/120
Max Compr Power input Circuit 1/Circuit 2	kW	61/61	72/72	101/72	101/101	101/101	124/101	124/101	124/124	147/101	147/124	147/124	147/147	147/147	156/156
Max Amps Circuit 1 / Circuit 2 (3) (4)	(A)	93/93	110/110	153/110	153/153	153/153	188/153	188/153	188/188	224/153	224/188	224/188	224/224	224/224	236/236
Start up Amps Circuit 1 / Circuit 2 (3) (4)	(A)	93/93	110/110	153/110	153/153	153/153	188/153	188/153	188/188	224/153	224/188	224/188	224/224	224/224	236/236
Motor RPM	(rpm)	3000	3000	3000	3000	3000	3000	3000	3000	3000	3000	3000	3000	3000	3000
Oil sump heater Circuit 1 / Circuit 2	(W)	150/150	150/150	150/150	150/150	150/150	150/150	150/150	150/150	150/150	150/150	150/150	150/150	150/150	150/150
Evaporator															
Quantity	#	1	1	1	1	1	1	1	1	1	1	1	1	1	1
Type		Flooded shell and tube heat exchanger													
Evaporator model		115B	115A	165B	165B	165B	165A	165A	200B	200B	200B	200B	250C	250C	250B
Evaporator Water Content volume	(l)	51	58	74	74	74	78	78	99	99	99	99	109	109	118
Antifreeze Heater	(W)	1640	1640	1640	1640	1640	1640	1640	2040	2040	2040	2040	2040	2040	2040
Two pass evaporator															
Evap. Water Flow rate - Minimum	(l/s)	8.0	9.4	11.6	11.6	11.6	12.4	12.4	14.2	14.2	14.2	14.2	16.2	16.2	17.9
Evap. Water Flow rate - Maximum (5)	(l/s)	29.6	34.7	43.1	43.1	43.1	46.0	46.0	52.6	52.6	52.6	52.6	60.3	60.3	66.5
Nominal water connection size (Grooved coupling)	(in) - (DN)	4" - 100	4" - 100	5" - 125	5" - 125	5" - 125	5" - 125	5" - 125	6" - 150	6" - 150	6" - 150	6" - 150	6" - 150	6" - 150	6" - 150
Two pass evaporator with turbulator															
Evap. Water Flow rate - Minimum (5)	(l/s)	6.6	7.8	9.7	9.7	9.7	10.3	10.3	11.8	11.8	11.8	11.8	13.5	13.5	14.9
Evap. Water Flow rate - Maximum	(l/s)	26.6	31.2	38.7	38.7	38.7	41.3	41.3	47.2	47.2	47.2	47.2	54.1	54.1	59.7
Nominal water connection size (Grooved coupling)	(in) - (mm)	4" - 100	4" - 100	5" - 125	5" - 125	5" - 125	5" - 125	5" - 125	6" - 150	6" - 150	6" - 150	6" - 150	6" - 150	6" - 150	6" - 150
Hydraulic Module Components															
Standard head pressure pump option (Twin pump)															
Available Head Pressure (1)	(kPa)	141	128	142	121	121	179	179	NA	172	153	153	148	148	148
Max Motor Power input	(kW)	5.5	5.5	7.5	7.5	7.5	11.0	11.0	NA	11.0	11.0	11.0	11.0	11.0	11.0
Max Amps	(A)	11	11	14	14	14	21	21	NA	21	21	21	21	21	21
High head pressure pump option (Twin Pump)															
Available Head Pressure (1)	(kPa)	253	239	224	NA	245	NA	237	NA	230	264	264	259	259	259
Max Motor Power input	(kW)	11.0	11.0	11.0	NA	15.0	NA	15.0	NA	15.0	18.5	18.5	18.5	18.5	18.5
Max Amps	(A)	21	21	21	NA	28	NA	28	NA	28	35	35	35	35	35
Expansion Tank Volume	(l)	80	80	80	NA	80	NA	80	NA	80	80	80	80	80	80
Max User water loop Volume for factory mounted expansion tank (1)	(l)	6000	6000	6000	NA	6000	NA	6000	NA	6000	6000	6000	6000	6000	6000
Max. Water-side Operating Pressure without pump package	(kPa)	1000	1000	1000	NA	1000	NA	1000	NA	1000	1000	1000	1000	1000	1000
Max. Water-side Operating Pressure with pump package	(kPa)	450	450	450	NA	450	NA	450	NA	450	450	450	450	450	450
Antifreeze Heater with pump package	(W)	2360	2360	2360	2360	2360	2360	2360	2760	2760	2760	2760	2760	2760	2760

General Data

Table 11a – General Data RTAF 090-245 High Seasonal Efficiency Short- Standard and Low Noise- R134a- R513A (continued)

		RTAF 090	RTAF 105	RTAF 125	RTAF 140	RTAF 145	RTAF 150	RTAF 155	RTAF 170	RTAF 175	RTAF 185	RTAF 190	RTAF 200	RTAF 205	RTAF 245 (9)
		HSS LN	HSS LN	HSS LN	HSS LN	HSS LN	HSS LN	HSS LN	HSS LN	HSS LN	HSS LN	HSS LN	HSS LN	HSS LN	HSS LN
Condenser															
Type		Full aluminum Micro channel heat exchanger													
Quantity	#	4/4	4/4	4/4	4/4	5/5	4/4	5/5	4/4	6/4	5/5	6/6	5/5	6/6	6/6
Face area per coil	(m ²)	2.4	2.4	2.4	2.4	2.4	2.4	2.4	2.4	2.4	2.4	2.4	2.4	2.4	2.4
Condenser Fan															
Quantity	#	4/4	4/4	4/4	4/4	5/5	4/4	5/5	4/4	6/4	5/5	6/6	5/5	6/6	6/6
Diameter	(mm)	800	800	800	800	800	800	800	800	800	800	800	800	800	800
Standard / High ambient fan option															
Fan / motor Type		Propeller fan / Variable speed - EC motor													
Airflow per Fan	(m ³ /h)	15000	17400	17400	17400	17400	17400	17400	20000	20000	20000	20000	20000	20000	20000
Max Power input per Motor	(kW)	0.6	0.9	0.9	0.9	0.9	0.9	0.9	1.3	1.3	1.3	1.3	1.3	1.3	1.3
Max Amps per Motor	(A)	1.1	1.6	1.6	1.6	1.6	1.6	1.6	2.3	2.3	2.3	2.3	2.3	2.3	2.3
Motor RPM	(rpm)	710	810	810	810	810	810	810	910	910	910	910	910	910	910
Low ambient fan option															
Fan / motor Type		Propeller fan / Variable speed - EC motor													
Airflow per Fan	(m ³ /h)	15000	17400	17400	17400	17400	17400	17400	20000	20000	20000	20000	20000	20000	20000
Max Power input per Motor	(kW)	0.6	0.9	0.9	0.9	0.9	0.9	0.9	1.3	1.3	1.3	1.3	1.3	1.3	1.3
Max Amps per Motor	(A)	1.1	1.6	1.6	1.6	1.6	1.6	1.6	2.3	2.3	2.3	2.3	2.3	2.3	2.3
Motor RPM	(rpm)	710	810	810	810	810	810	810	910	910	910	910	910	910	910
System data (4)															
Nb of refrigerant circuit	#	2	2	2	2	2	2	2	2	2	2	2	2	2	2
Minimum cooling load % (6)	%	30	30	20	20	20	20	20	20	20	20	20	20	20	20
R134a/R513A refrigerant charge Circuit 1 / Circuit 2 (7)	(kg)	41/39	40/38	42/38	42/40	45/43	44/38	47/41	54/40	57/43	56/50	59/53	60/56	63/59	63/59
Oil charge Circuit 1 / Circuit 2	(l)	6/6	6/6	6/6	6/6	6/6	7/6	7/6	7/6	7/6	7/7	7/7	8/8	8/8	8/8
POE Oil type		OIL00317 or OIL00311													

- (1) Indicative performance at Evaporator water temperature: 12°C / 7°C- Condenser air temperature 35°C- for detailed performances consult Order Write Up.
- (2) Under 400V/3/50Hz.
- (3) Rated Condition without Pump Package.
- (4) Electrical & system data are indicative and subject to change without notice. Please refer to unit nameplate data.
- (5) Not applicable for Glycol application- see tables with Minimum Flow with Glycol.
- (6) Max speed- range is 60% to 100% of max speed.
- (7) Refrigerant charge may vary according to option- for instance +20% for process (digit 19 = p). For real value refer to unit nameplate.
- (8) Data containing information on two circuits shown as follows: ckt1/ckt2.
- (9) 245 HSS is available in low and standard ambient (not available in high ambient).

General Data

Table 11b – General data RTAF 090-225 High Seasonal Efficiency Short - Standard and Low noise - R1234ze

		RTAF	RTAF	RTAF	RTAF	RTAF	RTAF	RTAF	RTAF	RTAF	RTAF
		090	100	110	120	130	145	155	185	200	225
		HSS LN	HSS LN	HSS LN	HSS LN	HSS LN	HSS LN	HSS LN	HSS LN	HSS LN	HSS LN
Cooling Capacity (1)	(kW)	320	349	386	416	448	502	543	608	722	839
Unit electrical data (2) (3) (4)											
Maximum Power input in cooling	(kW)	166	180	194	218	241	266	288	292	335	382
Unit amps (4) (5)											
Unit rated amps (Max compressor+fan+control)	(A)	253	275	296	332	368	406	439	445	510	581
Unit start up amps starting Amps of the largest compr+RLA of 2nd compr+RLA of all fans+control)	(A)	253	275	296	332	368	406	439	445	510	581
Displacement Power Factor (DPF)	mm ²	0.95	0.95	0.95	0.95	0.95	0.95	0.95	0.95	0.95	0.95
Max power cable cross section											
Power factor	(kA)	1*240	1*240	1*240	1*240	1*240	2*300	2*300	2*300	2*300	2*300
Disconnect switch size	(A)	400	400	500	500	500	630	630	630	800	800
Compressor											
Quantity	#	2	2	2	2	2	2	2	2	2	2
Type		Screw	Screw	Screw	Screw	Screw	Screw	Screw	Screw	Screw	Screw
Model (8)		45/45	55/45	55/55	65/55	65/65	78/65	78/78	78/78	78/78	78/78
Max Compr Power input Circuit 1 / Circuit 2	kW	74/74	89/74	89/89	112/89	112/112	134/112	134/134	134/134	155/155	179/179
Max Amps Circuit1 / Circuit 2 (3) (4)	(A)	45/45	55/45	55/55	65/55	65/65	78/65	78/78	78/78	78/78	78/78
Start up Amps Circuit1 / Circuit 2 (3)(4)	(A)	113/113	135/113	135/135	171/135	171/171	203/171	203/203	203/203	236/236	271/271
Motor RPM	(rpm)	3000	3000	3000	3000	3000	3000	3000	3000	3600	4200
Oil sump heater Circuit1 / Circuit 2	(W)	0.550	0.550	0.550	0.550	0.550	0.550	0.550	0.550	0.550	0.550
Evaporator											
Quantity	#	1	1	1	1	1	1	1	1	1	1
Type		Flooded shell and tube heat exchanger									
Evaporator model		115B	115A	115A	165C	165B	200C	200C	200B	250B	250B
Evaporator Water Content volume	(l)	51	58	58	64	74	89	89	99	118	118
Antifreeze Heater	(W)	1640	1640	1640	1640	1640	1640	1640	2040	2040	2040
Evap. Water Flow rate - Minimum (6)											
Evap. Water Flow rate - Maximum	(l/s)	8.0	9.4	9.4	11.1	11.6	13.0	13.0	14.2	17.9	17.9
Evap. Water Flow rate - Maximum	(l/s)	29.6	34.7	34.7	41.2	43.1	48.0	48.0	52.6	66.5	66.5
Nominal water connection size (Grooved coupling)	(in) - (mm)	4" - 100	4" - 100	4" - 100	5" - 125	5" - 125	6" - 150	6" - 150	6" - 150	6" - 150	6" - 150
Evap. Water Flow rate - Minimum (6)											
Evap. Water Flow rate - Minimum	(l/s)	6.6	7.8	7.8	9.3	9.7	10.8	10.8	11.8	14.9	14.9
Evap. Water Flow rate - Maximum	(l/s)	26.6	31.2	31.2	37.0	38.7	43.1	43.1	47.2	59.7	59.7
Nominal water connection size (Grooved coupling)	(in) - (mm)	4" - 100	4" - 100	4" - 100	5" - 125	5" - 125	6" - 150	6" - 150	6" - 150	6" - 150	6" - 150
Hydraulic Module Components											
Standard head pressure pump option (twin pumps)											
Standard head pressure pump option											
Available Head Pressure (1)	(kPa)	129	126	111	107	136	121	160	151	131	89
Max Amps	(kW)	5.5	5.5	5.5	5.5	7.5	7.5	11.0	11.0	11.0	11.0
High head pressure pump option (twin pumps)	(A)	11.0	11.0	11.0	11.0	14.4	14.4	20.8	20.8	20.8	20.8
High head pressure pump option											
Available Head Pressure (1)	(kPa)	246	243	227	222	212	237	226	218	244	197
Max Amps	(kW)	11.0	11.0	11.0	11.0	11.0	15.0	15.0	15.0	18.5	18.5
Max. Rated Amps	(A)	20.8	20.8	20.8	20.8	20.8	28.0	28.0	28.0	34.5	34.5
Expansion Tank Volume	(l)	80	80	80	80	80	80	80	80	80	80
Max User water loop Volume for factory mounted expansion tank (1)	(l)	6000	6000	6000	6000	6000	6000	6000	6000	6000	6000
Max. Water-side Operating Pressure without pump package	(kPa)	1000	1000	1000	1000	1000	1000	1000	1000	1000	1000
Max. Water-side Operating Pressure with pump package	(kPa)	450	450	450	450	450	450	450	450	450	450
Antifreeze Heater with pump package	(W)	2360	2360	2360	2360	2360	2360	2360	2760	2760	2760
Condenser											
Type		Full aluminum Micro channel heat exchanger									
Quantity	#	4/4	4/4	4/4	4/4	4/4	5/5	5/5	6/6	6/6	6/6
Face area per coil	(m ²)	2.4	2.4	2.4	2.4	2.4	2.4	2.4	2.4	2.4	2.4
Condenser Fan (nominal conditions)											
Quantity	#	4/4	4/4	4/4	4/4	4/4	5/5	5/5	6/6	6/6	6/6
Diameter	(mm)	800	800	800	800	800	800	800	800	800	800

General Data

Table 11b – General data RTAF 090-225 High Seasonal Efficiency Short - Standard and Low noise - R1234ze (continued)

		RTAF 090	RTAF 100	RTAF 110	RTAF 120	RTAF 130	RTAF 145	RTAF 155	RTAF 185	RTAF 200	RTAF 225
		HSS SN LN	HSS SN LN	HSS SN LN	HSS SN LN	HSS SN LN	HSS SN LN	HSS SN LN	HSS SN LN	HSS SN LN	HSS SN LN
Standard / High ambient fan option											
Fan / motor Type		Propeller fan / Variable speed - EC motor									
Max Power input per Motor	(m ³ /h)	15000	15000	17400	17400	17400	17400	17400	20000	20000	20000
Max Amps per Motor	(kW)	0.6	0.6	0.9	0.9	0.9	0.9	0.9	1.3	1.3	1.3
Motor RPM	(A)	1.1	1.1	1.6	1.6	1.6	1.6	1.6	2.3	2.3	2.3
Rated motor RPM	(rpm)	710	710	810	810	810	810	810	910	910	910
Low ambient fan option											
Fan / motor Type		Propeller fan / Variable speed - EC motor									
Max Power input per Motor	(m ³ /h)	15000	15000	17400	17400	17400	17400	17400	20000	20000	20000
Max Amps per Motor	(kW)	0.6	0.6	0.9	0.9	0.9	0.9	0.9	1.3	1.3	1.3
Motor RPM	(A)	1.1	1.1	1.6	1.6	1.6	1.6	1.6	2.3	2.3	2.3
Maximum ambient operation High ambient (8)	(rpm)	710	710	810	810	810	810	810	910	910	910
System data											
Nb of refrigerant circuit	#	2	2	2	2	2	2	2	2	2	2
Minimum cooling load % (6)	%	30	30	30	30	30	30	30	30	30	30
Refrigerant charge Circuit 1 / Circuit 2	(kg)	41/39	40/38	40/38	41/42	42/40	55/45	55/45	60/46	63/59	63/59
Oil charge Circuit 1 / Circuit 2	(l)	5/5	5/5	5/5	6/5	6/6	6/6	6/6	6/6	7/7	7/7
POE Oil type (10)		OIL00317 or OIL00315									

- (1) Indicative performance at Evaporator water temperature: 12°C / 7°C - Condenser air temperature 35°C - for detailed performances consult Order Write Up.
- (2) Under 400V/3/50Hz.
- (3) Rated Condition without Pump Package.
- (4) Percent minimum load may be adjusted around 15%-20% according to operating conditions by local sales office.
- (5) Electrical & system data are indicative and subject to change without notice. Please refer to unit nameplate data.
- (6) Not applicable for Glycol application - see tables with Minimum Flow with Glycol.
- (7) Max speed - range is 60% to 100% of max speed.
- (8) Refrigerant charge may vary according to option - for instance +20% for process (digit 19 = p). For real value refer to unit nameplate.
- (9) Data containing information on two circuits shown as follows: ckt1/ckt2.
- (10) OIL0066E or OIL0067E may have been used on early orders and there is no restriction to continue to use them but preferable oil is OIL00315 or OIL00317.



General Data

Table 12a – General Data RTAF 090-245 High Seasonal Efficiency Short - Extra Low Noise - R134a - R513A

		RTAF 090	RTAF 105	RTAF 125	RTAF 140	RTAF 145	RTAF 150	RTAF 155	RTAF 170	RTAF 175	RTAF 185	RTAF 190	RTAF 200	RTAF 205	RTAF 245 (9)
		HSS XLN	HSS XLN	HSS XLN	HSS XLN	HSS XLN	HSS XLN	HSS XLN	HSS XLN	HSS XLN	HSS XLN	HSS XLN	HSS XLN	HSS XLN	HSS XLN
Cooling Capacity (1)	(kW)	330	378	443	509	526	545	567	582	617	656	676	706	731	839
Unit electrical data (2) (3) (4)															
Maximum Power input in cooling	(kW)	140	161	190	219	223	242	246	265	269	292	296	315	319	339
Unit rated amps (Max compr +Fan+Control)	(A)	214	247	290	334	340	369	375	404	410	445	451	481	487	516
Unit start up amps (Starting Amps of the largest compr+RLA of 2nd compr+RLA of all fans+ control)	(A)	214	247	290	334	340	369	375	404	410	445	451	481	487	516
Displacement Power Factor (DPF)		0.95	0.95	0.95	0.95	0.95	0.95	0.95	0.95	0.95	0.95	0.95	0.95	0.95	0.95
Max power cable cross section	(mm ²)	1x240	1x240	1x240	2x300	2x300	2x300	2x300	2x300	2x300	2x300	2x300	2x300	2x300	2x300
Disconnect switch size	(A)	400	400	500	630	630	630	630	630	630	800	800	800	800	800
Compressor															
Quantity	#	2	2	2	2	2	2	2	2	2	2	2	2	2	2
Type		Screw	Screw	Screw	Screw	Screw	Screw	Screw	Screw	Screw	Screw	Screw	Screw	Screw	Screw
Model (9)		45/45	50/50	70/50	70/70	70/70	85/70	85/70	85/85	100/70	100/85	100/85	100/100	100/100	120/120
Max Compr Power input Circuit 1/Circuit 2	(kW)	61/61	72/72	101/72	101/101	101/101	124/101	124/101	124/124	147/101	147/124	147/124	147/147	147/147	156/156
Max Amps Circuit 1 / Circuit 2 (3) (4)	(A)	93/93	110/110	153/110	153/153	153/153	188/153	188/153	188/188	224/153	224/188	224/188	224/224	224/224	236/236
Start up Amps Circuit 1 / Circuit 2 (3) (4)	(A)	93/93	110/110	153/110	153/153	153/153	188/153	188/153	188/188	224/153	224/188	224/188	224/224	224/224	236/236
Motor RPM	(rpm)	3000	3000	3000	3000	3000	3000	3000	3000	3000	3000	3000	3000	3000	3000
Oil sump heater Circuit 1 / Circuit 2	(W)	150/150	150/150	150/150	150/150	150/150	150/150	150/150	150/150	150/150	150/150	150/150	150/150	150/150	150/150
Evaporator															
Quantity	#	1	1	1	1	1	1	1	1	1	1	1	1	1	1
Type		Flooded shell and tube heat exchanger													
Evaporator model		115B	115A	165B	165B	165B	165A	165A	200B	200B	200B	200B	250C	250C	250B
Evaporator Water Content volume	(l)	51	58	74	74	74	78	78	99	99	99	99	109	109	118
Antifreeze Heater	(W)	1640	1640	1640	1640	1640	1640	1640	2040	2040	2040	2040	2040	2040	2040
Two pass evaporator															
Evap. Water Flow rate - Minimum	(l/s)	8.0	9.4	11.6	11.6	11.6	12.4	12.4	14.2	14.2	14.2	14.2	16.2	16.2	17.9
Evap. Water Flow rate - Maximum (5)	(l/s)	29.6	34.7	43.1	43.1	43.1	46.0	46.0	52.6	52.6	52.6	52.6	60.3	60.3	66.5
Nominal water connection size (Grooved coupling)	(in) - (DN)	4" - 100	4" - 100	5" - 125	5" - 125	5" - 125	5" - 125	5" - 125	6" - 150	6" - 150	6" - 150	6" - 150	6" - 150	6" - 150	6" - 150
Two pass evaporator with turbulator															
Evap. Water Flow rate - Minimum (5)	(l/s)	6.6	7.8	9.7	9.7	9.7	10.3	10.3	11.8	11.8	11.8	11.8	13.5	13.5	14.9
Evap. Water Flow rate - Maximum	(l/s)	26.6	31.2	38.7	38.7	38.7	41.3	41.3	47.2	47.2	47.2	47.2	54.1	54.1	59.7
Nominal water connection size (Grooved coupling)	(in) - (mm)	4" - 100	4" - 100	5" - 125	5" - 125	5" - 125	5" - 125	5" - 125	6" - 150	6" - 150	6" - 150	6" - 150	6" - 150	6" - 150	6" - 150
Hydraulic Module Components															
Standard head pressure pump option (Twin pump)															
Available Head Pressure (1)	(kPa)	142	128	143	122	122	179	179	NA	172	153	153	148	148	148
Max Motor Power input	(kW)	5.5	5.5	7.5	7.5	7.5	11.0	11.0	NA	11.0	11.0	11.0	11.0	11.0	11.0
Max Amps	(A)	11	11	14	14	14	21	21	NA	21	21	21	21	21	21
High head pressure pump option (Twin Pump)															
Available Head Pressure (1)	(kPa)	253	240	224	NA	245	NA	237	NA	230	264	264	259	259	259
Max Motor Power input	(kW)	11.0	11.0	11.0	NA	15.0	NA	15.0	NA	15.0	18.5	18.5	18.5	18.5	18.5
Max Amps	(A)	21	21	21	NA	28	NA	28	NA	28	35	35	35	35	35
Expansion Tank Volume	(l)	80	80	80	NA	80	NA	80	NA	80	80	80	80	80	80
Max User water loop Volume for factory mounted expansion tank (1)	(l)	6000	6000	6000	NA	6000	NA	6000	NA	6000	6000	6000	6000	6000	6000
Max. Water-side Operating Pressure without pump package	(kPa)	1000	1000	1000	NA	1000	NA	1000	NA	1000	1000	1000	1000	1000	1000
Max. Water-side Operating Pressure with pump package	(kPa)	450	450	450	NA	450	NA	450	NA	450	450	450	450	450	450
Antifreeze Heater with pump package	(W)	2360	2360	2360	2360	2360	2360	2360	2760	2760	2760	2760	2760	2760	2760

General Data

Table 12a – General Data RTAF 090-245 High Seasonal Efficiency Short- Extra Low Noise - R134a - R513A (continued)

		RTAF 090 HSS XLN	RTAF 105 HSS XLN	RTAF 125 HSS XLN	RTAF 140 HSS XLN	RTAF 145 HSS XLN	RTAF 150 HSS XLN	RTAF 155 HSS XLN	RTAF 170 HSS XLN	RTAF 175 HSS XLN	RTAF 185 HSS XLN	RTAF 190 HSS XLN	RTAF 200 HSS XLN	RTAF 205 HSS XLN	RTAF 245 (9) HSS XLN
Condenser															
Type		Full aluminum Micro channel heat exchanger													
Quantity	#	4/4	4/4	4/4	4/4	5/5	4/4	5/5	4/4	6/4	5/5	6/6	5/5	6/6	6/6
Face area per coil	(m ²)	2.4	2.4	2.4	2.4	2.4	2.4	2.4	2.4	2.4	2.4	2.4	2.4	2.4	2.4
Condenser Fan															
Quantity	#	4/4	4/4	4/4	4/4	5/5	4/4	5/5	4/4	6/4	5/5	6/6	5/5	6/6	6/6
Diameter	(mm)	800	800	800	800	800	800	800	800	800	800	800	800	800	800
Standard / High ambient fan option															
Fan / motor Type		Propeller fan / Variable speed - EC motor													
Airflow per Fan	(m ³ /h)	15000	17400	17400	17400	17400	17400	17400	20000	20000	20000	20000	20000	20000	20000
Max Power input per Motor	(kW)	0.5	0.8	0.8	0.8	0.8	0.8	0.8	1.1	1.1	1.1	1.1	1.1	1.1	1.1
Max Amps per Motor	(A)	0.8	1.2	1.2	1.2	1.2	1.2	1.2	1.8	1.8	1.8	1.8	1.8	1.8	1.8
Motor RPM	(rpm)	660	760	760	760	760	760	760	860	860	860	860	860	860	860
Low ambient fan option															
Fan / motor Type		Propeller fan / Variable speed - EC motor													
Airflow per Fan	(m ³ /h)	15000	17400	17400	17400	17400	17400	17400	20000	20000	20000	20000	20000	20000	20000
Max Power input per Motor	(kW)	0.5	0.8	0.8	0.8	0.8	0.8	0.8	1.1	1.1	1.1	1.1	1.1	1.1	1.1
Max Amps per Motor	(A)	0.8	1.2	1.2	1.2	1.2	1.2	1.2	1.8	1.8	1.8	1.8	1.8	1.8	1.8
Motor RPM	(rpm)	660	760	760	760	760	760	760	860	860	860	860	860	860	860
System data (4)															
Nb of refrigerant circuit	#	2	2	2	2	2	2	2	2	2	2	2	2	2	2
Minimum cooling load % (6)	%	30 or 15%													
R134a/R513A refrigerant charge Circuit 1 / Circuit 2 (7)	(kg)	41/39	40/38	42/38	42/40	45/43	44/38	47/41	54/40	57/43	56/50	59/53	60/56	63/59	63/59
Oil charge Circuit 1 / Circuit 2	(l)	6/6	6/6	6/6	6/6	6/6	7/6	7/6	7/6	7/6	7/7	7/7	8/8	8/8	8/8
POE Oil type		OIL00317 or OIL00311													

- (1) Indicative performance at Evaporator water temperature: 12°C / 7°C - Condenser air temperature 35°C - for detailed performances consult Order Write Up.
- (2) Under 400V/3/50Hz.
- (3) Rated Condition without Pump Package.
- (4) Electrical & system data are indicative and subject to change without notice. Please refer to unit nameplate data.
- (5) Not applicable for Glycol application - see tables with Minimum Flow with Glycol.
- (6) Max speed - range is 60% to 100% of max speed.
- (7) Refrigerant charge may vary according to option - for instance +20% for process (digit 19=P). For real value refer to unit nameplate.
- (8) Data containing information on two circuits shown as follows: ckt1/ckt2.
- (9) 245 HSS is available in low and standard ambient (not available in high ambient).

General Data

Table 12b – General data RTAF 090-225 High Seasonal Efficiency Short - Extra Low Noise - R1234 ze

		RTAF 090	RTAF 100	RTAF 110	RTAF 120	RTAF 130	RTAF 145	RTAF 155	RTAF 185	RTAF 200	RTAF 225
		HSS XLN	HSS XLN	HSS XLN	HSS XLN	HSS XLN	HSS XLN	HSS XLN	HSS XLN	HSS XLN	HSS XLN
Cooling Capacity (1)	(kW)	319	348	385	426	448	501	542	608	722	839
Unit electrical data (2) (3) (4)											
Maximum Power input in cooling	(kW)	166	180	194	218	241	266	288	292	335	382
Unit rated amps (Max compressor+fan+control)	(A)	253	275	296	332	368	406	439	445	510	581
Unit start up amps starting Amps of the largest compr+RLA of 2nd compr+RLA of all fans+control)	(A)	253	275	296	332	368	406	439	445	510	581
Displacement Power Factor (DPF)		0.95	0.95	0.95	0.95	0.95	0.95	0.95	0.95	0.95	0.95
Max power cable cross section	mm ²	1*240	1*240	1*240	1*240	1*240	2*300	2*300	2*300	2*300	2*300
Disconnect switch size	(A)	400	400	500	500	500	630	630	630	800	800
Compressor											
Quantity	#	2	2	2	2	2	2	2	2	2	2
Type		Screw	Screw	Screw	Screw	Screw	Screw	Screw	Screw	Screw	Screw
Model (9)		45/45	55/45	55/55	65/55	65/65	78/65	78/78	78/78	78/78	78/78
Max Compr Power input (Circuit 1 / Circuit 2)	kW	74/74	89/74	89/89	112/89	112/112	134/112	134/134	134/134	155/155	179/179
Max Amps Circuit1 / Circuit 2 (3) (5)	(A)	113/113	135/113	135/135	171/135	171/171	203/171	203/203	203/203	236/236	271/271
Start up Amps Circuit1 / Circuit 2 (3)(5)	(A)	113/113	135/113	135/135	171/135	171/171	203/171	203/203	203/203	236/236	271/271
Motor RPM	(rpm)	3000	3000	3000	3000	3000	3000	3000	3000	3600	4200
Oil sump heater Circuit1 / Circuit 2	(W)	550	550	550	550	550	550	550	550	550	550
Evaporator											
Quantity	#	1	1	1	1	1	1	1	1	1	1
Type		Flooded shell and tube heat exchanger									
Evaporator model		115B	115A	115A	165C	165B	200C	200C	200B	250B	250B
Evaporator Water Content volume	(l)	51	58	58	64	74	89	89	99	118	118
Antifreeze Heater	(W)	1640	1640	1640	1640	1640	1640	1640	2040	2040	2040
Two pass evaporator											
Evap. Water Flow rate - Minimum (6)	(l/s)	8.0	9.4	9.4	11.1	11.6	13.0	13.0	14.2	17.9	17.9
Evap. Water Flow rate - Maximum	(l/s)	29.6	34.7	34.7	41.2	43.1	48.0	48.0	52.6	66.5	66.5
Nominal water connection size (Grooved coupling)	(in) - (mm)	4" - 100	4" - 100	4" - 100	5" - 125	5" - 125	6" - 150	6" - 150	6" - 150	6" - 150	6" - 150
Two pass evaporator with turbulator											
Evap. Water Flow rate - Minimum (6)	(l/s)	6.6	7.8	7.8	9.3	9.7	10.8	10.8	11.8	14.9	14.9
Evap. Water Flow rate - Maximum	(l/s)	26.6	31.2	31.2	37.0	38.7	43.1	43.1	47.2	59.7	59.7
Nominal water connection size (Grooved coupling)	(in) - (mm)	4" - 100	4" - 100	4" - 100	5" - 125	5" - 125	6" - 150	6" - 150	6" - 150	6" - 150	6" - 150
Hydraulic Module Components											
Standard head pressure pump option (twin pumps)											
Available Head Pressure (1)	(kPa)	129	126	111	107	136	121	160	151	131	89
Max. Motor Power	(kW)	5.5	5.5	5.5	5.5	7.5	7.5	11.0	11.0	11.0	11.0
Max Amps	(A)	11.0	11.0	11.0	11.0	14.4	14.4	20.8	20.8	20.8	20.8
High head pressure pump option (twin pumps)											
Available Head Pressure (1)	(kPa)	246	243	227	222	212	237	226	218	244	197
Max. Motor Power	(kW)	11.0	11.0	11.0	11.0	11.0	15.0	15.0	15.0	18.5	18.5
Max Amps	(A)	20.8	20.8	20.8	20.8	20.8	28.0	28.0	28.0	34.5	34.5
Expansion Tank Volume	(l)	80	80	80	80	80	80	80	80	80	80
Max User water loop Volume for factory mounted expansion tank (1)	(l)	6000	6000	6000	6000	6000	6000	6000	6000	6000	6000
Max. Water-side Operating Pressure without pump package	(kPa)	1000	1000	1000	1000	1000	1000	1000	1000	1000	1000
Max. Water-side Operating Pressure with pump package	(kPa)	450	450	450	450	450	450	450	450	450	450
Antifreeze Heater with pump package	(W)	2360	2360	2360	2360	2360	2360	2360	2760	2760	2760
Condenser											
Type											
Quantity	#	4/4	4/4	4/4	4/4	4/4	5/5	5/5	6/6	6/6	6/6
Face area per coil	(m ²)	2.4	2.4	2.4	2.4	2.4	2.4	2.4	2.4	2.4	2.4
Condenser Fan (nominal conditions)											
Quantity	#	4/4	4/4	4/4	4/4	4/4	5/5	5/5	6/6	6/6	6/6
Diameter	(mm)	800	800	800	800	800	800	800	800	800	800

General Data

Table 12b – General data RTAF 090-225 High Seasonal Efficiency Short- Extra Low Noise - R1234 ze (continued)

		RTAF 090	RTAF 100	RTAF 110	RTAF 120	RTAF 130	RTAF 145	RTAF 155	RTAF 185	RTAF 200	RTAF 225
		HSS XLN	HSS XLN	HSS XLN	HSS XLN	HSS XLN	HSS XLN	HSS XLN	HSS XLN	HSS XLN	HSS XLN
Standard / High ambient fan option											
Fan / motor Type		Propeller fan / Variable speed - EC motor									
Airflow per Fan	(m ³ /h)	15000	15000	17400	17400	17400	17400	17400	20000	20000	20000
Max Power input per Motor	(kW)	0.5	0.5	0.8	0.8	0.8	0.8	0.8	1.1	1.1	1.1
Max Amps per Motor	(A)	0.8	0.8	1.2	1.2	1.2	1.2	1.2	1.8	1.8	1.8
Motor RPM	(rpm)	660	660	760	760	760	760	760	860	860	860
Low ambient fan option											
Fan / motor Type		Propeller fan / Variable speed - EC motor									
Airflow per Fan	(m ³ /h)	15000	15000	17400	17400	17400	17400	17400	20000	20000	20000
Max Power input per Motor	(kW)	0.5	0.5	0.8	0.8	0.8	0.8	0.8	1.1	1.1	1.1
Max Amps per Motor	(A)	0.8	0.8	1.2	1.2	1.2	1.2	1.2	1.8	1.8	1.8
Motor RPM	(rpm)	660	660	760	760	760	760	760	860	860	860
System data											
Nb of refrigerant circuit	#	2	2	2	2	2	2	2	2	2	2
Minimum cooling load % (6)	%	30	30	30	30	30	30	30	30	30	30
Refrigerant charge Circuit 1 / Circuit 2	(kg)	41/39	40/38	40/38	41/42	42/40	55/45	55/45	60/46	63/59	63/59
Oil charge Circuit 1 / Circuit 2	(l)	5/5	5/5	5/5	6/5	6/6	6/6	6/6	6/6	7/7	7/7
POE Oil type (10)		OIL00317 or OIL00315									

- (1) Indicative performance at Evaporator water temperature: 12°C / 7°C - Condenser air temperature 35°C - for detailed performances consult Order Write Up.
- (2) Under 400V/3/50Hz.
- (3) Rated Condition without Pump Package.
- (4) Percent minimum load may be adjusted around 15%-20% according to operating conditions by local sales office.
- (5) Electrical & system data are indicative and subject to change without notice. Please refer to unit nameplate data.
- (6) Not applicable for Glycol application- see tables with Minimum Flow with Glycol.
- (7) Max speed- range is 60% to 100% of max speed.
- (8) Refrigerant charge may vary according to option- for instance +20% for process (digit 19 = p). For real value refer to unit nameplate.
- (9) Data containing information on two circuits shown as follows: ckt1/ckt2.
- (10) OIL0066E or OIL0067E may have been used on early orders and there is no restriction to continue to use them but preferable oil is OIL00315 or OIL00317.

General Data

Table 13a – General Data RTAF 250-450 Standard Efficiency - Standard and low Noise - R134a - R513A

		RTAF	RTAF	RTAF	RTAF	RTAF	RTAF	RTAF	RTAF
		250	280	310	350	355 (10)	380	410	450 (10)
		SE SN LN	SE SN LN	SE SN LN	SE SN LN	SE SN LN	SE SN LN	SE SN LN	SE SN LN
Cooling Capacity (1)	(kW)	857	971	1073	1192	1173	1321	1445	1588
Unit electrical data (2) (3) (5)									
Maximum Power input in cooling	(kW)	369	418	464	520	523	570	619	698
Unit rated amps (Max compr +Fan+Control)	(A)	628	710	788	880	886	966	1052	1185
Unit start up amps (Starting Amps of the largest compr+RLA of 2nd compr+RLA of all fans+ control)	(A)	781	863	902	1033	968	1119	1166	1267
Displacement Power Factor (DPF)		0.85	0.85	0.85	0.86	0.86	0.86	0.85	0.86
Max power cable cross section	(mm ²)	4x185	4x185	4x185	4x185	4x185	4x185	4x185	6x185
Disconnect switch size	(A)	1250	1250	1250	1250	1250	1250	1250	1600
Compressor									
Quantity	#	3	3	3	4	3	4	4	4
Type		Screw	Screw	Screw	Screw	Screw	Screw	Screw	Screw
Model (9)		85-85/70	85-100/85	100-100/100	85-85/85-85	115-115/115	85-100/85-100	115-115/115-115	100-100/100-100
Max Compr Power input Circuit 1/ Circuit 2	(kW)	121-121/99	121-144/121	144-144/144	121-121/121-121	164-164/164	121-144/121-144	144-144/144-144	164-164/164-164
Max Amps Circuit 1 / Circuit 2 (3) (5)	(A)	201-201/166	201-240/201	240-240/240	201-201/201-201	273-273/273	201-240/201-240	240-240/240-240	273-273/273-273
Start up Amps Circuit 1 / Circuit 2 (3) (5)	(A)	354-354/291	354-354/354	354-354/354	354-354/354-354	354-354/354	354-354/354-354	354-354/354-354	354-354/354-354
Motor RPM	(rpm)	3000	3000	3000	3000	3000	3000	3000	3000
Oil sump heater Circuit 1 / Circuit 2	(W)	300/150	300/150	300/150	300/300	300/300	300/300	300/300	300/300
Evaporator									
Quantity	#	1	1	1	1	1	1	1	1
Type		Flooded shell and tube heat exchanger							
Evaporator model		300D	300B	300A	500D	300A	500C	500B	500B
Evaporator Water Content volume	(l)	97	108	120	146	120	159	170	170
Antifreeze Heater	(W)	2240	2240	2240	2440	2440	2440	2440	2440
Two pass evaporator									
Evap. Water Flow rate - Minimum	(l/s)	17.7	20.1	22.8	25.0	22.8	27.8	30.3	30.3
Evap. Water Flow rate - Maximum (6)	(l/s)	65.8	74.5	84.8	92.8	84.8	103.0	112.5	112.5
Nominal water connection size (Grooved coupling)	(in) - (DN)	6" - 150	6" - 150	6" - 150	8" - 200	6" - 150	8" - 200	8" - 200	8" - 200
Two pass evaporator with turbulator									
Evap. Water Flow rate - Minimum (6)	(l/s)	15	17	19	21	19	23	25	25
Evap. Water Flow rate - Maximum	(l/s)	59.1	66.9	76.1	83.4	76.1	92.5	101.1	101.1
Nominal water connection size (Grooved coupling)	(in) - (mm)	6" - 150	6" - 150	6" - 150	8" - 200	6" - 150	8" - 200	8" - 200	8" - 200
Hydraulic Module Components									
Standard head pressure pump option (Twin pump)									
Available Head Pressure (1)	(kPa)	167	118	95	146	82	134	120	80
Max Motor Power input	(kW)	15.0	15.0	15.0	22.0	15	22.0	22.0	22
Max Amps	(A)	28	28	28	39.7	28	39.7	39.7	39.7
High head pressure pump option (Twin Pump)									
Available Head Pressure (1)	(kPa)	223	229	193	NA	175	NA	NA	NA
Max Motor Power input	(kW)	18.5	22.0	22.0	NA	22	NA	NA	NA
Max Amps	(A)	34.5	39.7	39.7	NA	39.7	NA	NA	NA
Expansion Tank Volume	(l)	80	160	160	160	160	160	160	160
Max User water loop Volume for factory mounted expansion tank (1)	(l)	4000	8000	8000	8000	80000	8000	8000	4000
Max. Water-side Operating Pressure without pump package	(kPa)	1000	1000	1000	1000	1000	1000	1000	1000
Max. Water-side Operating Pressure with pump package	(kPa)	450	450	450	450	450	450	450	450
Antifreeze Heater with pump package	(W)	3300	3400	3400	3600	3400	3600	3600	3600
Condenser									
Type		Full aluminum Micro channel heat exchanger							
Quantity	#	10/4	10/6	10/6	10/8	10/6	10/10	12/10	12/10
Face area per coil	(m ²)	2.4	2.4	2.4	2.4	2.4	2.4	2.4	2.4
Condenser Fan									
Quantity	#	10/4	10/6	10/6	10/8	10/6	10/10	12/10	12/10
Diameter	(mm)	800	800	800	800	800	800	800	800
Standard / High ambient fan option									
Fan / motor Type		Propeller fan / Fixed speed - AC motor							
Airflow per Fan	(m ³ /h)	20000	20000	20000	20000	20000	20000	20000	20000
Max Power input per Motor	(kW)	1.4	1.4	1.4	1.4	1.4	1.4	1.4	1.4
Max Amps per Motor	(A)	3.4	3.4	3.4	3.4	3.4	3.4	3.4	3.4
Motor RPM	(rpm)	932	932	932	932	932	932	932	932

General Data

Table 13a – General Data RTAF 250-450 Standard Efficiency- Standard and low Noise - R134a - R513A (continued)

		RTAF	RTAF	RTAF	RTAF	RTAF	RTAF	RTAF	RTAF
		250	280	310	350	355 (10)	380	410	450 (10)
		SE SN LN	SE SN LN	SE SN LN	SE SN LN	SE SN LN	SE SN LN	SE SN LN	SE SN LN
Low ambient fan option									
Fan / motor Type		Propeller fan / Variable speed - EC motor							
Airflow per Fan	(m ³ /h)	20000	20000	20000	20000	20000	20000	20000	20000
Max Power input per Motor	(kW)	1.30	1.30	1.30	1.30	1.30	1.30	1.30	1.30
Max Amps per Motor	(A)	2	2	2	2	2	2	2	2
Motor RPM	(rpm)	910	910	910	910	910	910	910	910
System data (5)									
Nb of refrigerant circuit	#	2	2	2	2	2	2	2	2
Minimum cooling load % (4) (7)	%	15	15	15	15	15	15	15	15
R134a/R513A refrigerant charge Circuit 1 / Circuit 2 (8)	(kg)	93/45	96/49	97/52	94/91	97/52	98/100	107/104	107/104
Oil charge Circuit 1 / Circuit 2	(l)	16/8	16/8	16/8	16/16	16/8	16/16	16/16	16/16
POE Oil type		OIL0048E or OIL0023E							

(1) Indicative performance at Evaporator water temperature: 12°C / 7°C- Condenser air temperature 35°C- for detailed performances consult Order Write Up.

(2) Under 400V/3/50Hz.

(3) Rated Condition without Pump Package.

(4) Percent minimum load may be adjusted around 15%-20% according to operating conditions by local sales office.

(5) Electrical & system data are indicative and subject to change without notice. Please refer to unit nameplate data.

(6) Not applicable for Glycol application- see tables with Minimum Flow with Glycol.

(7) Max speed - range is 60% to 100% of max speed.

(8) Refrigerant charge may vary according to option - for instance +20% for process (digit 19=P). For real value refer to unit nameplate.

(9) Data containing information on two circuits shown as follows: ckt1/ckt2.

(10) Sizes 355 and 450 are not available with R513A.

General Data

Table 13b – General Data RTAF 210-340 Standard Efficiency - Standard and low Noise - R1234 ze

		RTAF	RTAF	RTAF	RTAF	RTAF	RTAF
		210	230	265	285	305	340
		SE SN LN	SE SN LN	SE SN LN	SE SN LN	SE SN LN	SE SN LN
Net Cooling Capacity (1)	(kW)	724	806	886	994	1080	1186
Unit electrical data (2) (3) (5)							
Maximum Power input in cooling	(kW)	349	403	408	481	535	539
Unit rated amps (Max compr+Fan+Control)	(A)	590	672	680	810	892	900
Unit start up amps (Starting Amps of the largest compr)	(A)	740	822	830	960	1042	1050
Displacement Power factor (DPF)		0.88	0.87	0.87	0.86	0.87	0.87
Max Power cable cross section	mm ²	4*185	4*185	4*185	4*185	4*185	4*185
Disconnect switch size	(A)	1250	1250	1250	1250	1250	1250
Compressor							
Quantity	#	3	3	3	4	4	4
Type		Screw	Screw	Screw	Screw	Screw	Screw
Model		65-78/65	78-78/78	78-78/78	65-78/65-78	78-78/78-78	78-78/78-78
Max Compr Power input Circuit1 / Circuit2	(kW)	98-125/ 98	125-125/ 125	125-125/ 125	98-125/ 98-125	125-125/ 125-125	125-125/ 125-125
Max Amps Circuit1 / Circuit 2 (3) (5)	(A)	163-204/ 163	204-204/ 204	204-204/ 204	163-204/ 163-204	204-204/ 204-204	204-204/ 204-204
Start up Amps Circuit1 / Circuit 2 (3)(5)	(A)	291-354/ 354	354-354/ 354	354-354/ 354	291-354/ 291-354	354-354/ 354-354	354-354/ 354-354
Motor RPM	(rpm)	3000	3000	3000	3000	3000	3000
Oil sump heater Circuit1 / Circuit 2	(W)	700	700	700	850	850	850
Evaporator							
Quantity	#	1	1	1	1	1	1
Type		Flooded shell and tube heat exchanger					
Evaporator model		300E	300D	300D	500E	500D	500D
Evaporator Water Content volume	(l)	86	97	97	130	146	146
Antifreeze Heater	(W)	2240	2240	2240	2440	2440	2440
Two pass evaporator							
Evap. Water Flow rate - Minimum	(l/s)	15.7	17.7	17.7	22.2	25.0	25.0
Evap. Water Flow rate - Maximum (6)	(l/s)	58.5	65.8	65.8	82.6	92.8	92.8
Nominal water connection size (Grooved coupling)	(in) - (mm)	6" - 150	6" - 150	6" - 150	8" - 200	8" - 200	8" - 201
Two pass evaporator with turbulator							
Evap. Water Flow rate - Minimum	(l/s)	13.2	14.8	14.8	18.5	20.8	20.8
Evap. Water Flow rate - Maximum (6)	(l/s)	52.5	59.1	59.1	74.2	83.4	83.4
Nominal water connection size (Grooved coupling)	(in) - (mm)	6" - 150	6" - 150	6" - 150	8" - 200	8" - 200	8" - 201
Hydraulic Module Components							
Standard head pressure pump option (Twin pump)							
Available Head Pressure (1)	(kPa)	N/A	N/A	N/A	N/A	N/A	N/A
Max. Motor Power Input	(kW)	11.0	11.0	15.0	15.0	15.0	22.0
Max. Rated Amps	(A)	20.8	20.8	29.0	29.0	29.0	39.7
High head pressure pump option (Twin pump)							
Available Head Pressure (1)	(kPa)	N/A	N/A	N/A	N/A	N/A	N/A
Max. Motor Power Input	(kW)	18.5	18.5	22.0	22.0	22.0	0.0
Max. Amps	(A)	34.5	34.5	39.7	39.7	39.7	0.0
Expansion Tank Volume	(l)	N/A	N/A	N/A	N/A	N/A	N/A
Max User water loop Volume for factory mounted expansion tank (1)	(l)	N/A	N/A	N/A	N/A	N/A	N/A
Max. Water-side Operating Pressure without pump package	(kPa)	N/A	N/A	N/A	N/A	N/A	N/A
Max. Water-side Operating Pressure with pump package	(kPa)	N/A	N/A	N/A	N/A	N/A	N/A
Antifreeze Heater with pump package	(W)	3300	3300	3400	3600	3600	3600
Condenser							
Type		Full aluminum Micro channel heat exchanger					
Quantity	#	10/4	10/4	10/6	10/8	10/8	10/10
Face area per coil	(m ²)	2.4	2.4	2.4	2.4	2.4	2.4
Condenser Fan							
Quantity	#	10/4	10/4	10/6	10/8	10/8	10/10
Diameter	(mm)	800	800	800	800	800	800
Standard / High ambient fan option							
Fan / motor Type		Propeller fan / Fixed speed - AC motor					
Airflow per Fan	(m ³ /h)	20000	20000	20000	20000	20000	20000
Max Power Input per Motor	(kW)	1.4	1.4	1.4	1.4	1.4	1.4
Max Amps per Motor	(A)	3.4	3.4	3.4	3.4	3.4	3.4
Motor RPM	(rpm)	932	932	932	932	932	932

General Data

Table 13b – General Data RTAF 210-340 Standard Efficiency - Standard and low Noise - R1234 ze (continued)

	RTAF 210		RTAF 230		RTAF 265		RTAF 285		RTAF 305		RTAF 340	
	SE	SN LN	SE	SN LN	SE	SN LN	SE	SN LN	SE	SN LN	SE	SN LN
Low ambient fan option												
Fan / motor Type	Propeller fan / Variable speed - EC motor											
Airflow per Fan	(m ³ /h)	20000	20000	20000	20000	20000	20000	20000	20000	20000	20000	20000
Max Power Input per Motor	(kW)	1.3	1.3	1.3	1.3	1.3	1.3	1.3	1.3	1.3	1.3	1.3
Max Amps per Motor	(A)	2.3	2.3	2.3	2.3	2.3	2.3	2.3	2.3	2.3	2.3	2.3
Motor RPM	(rpm)	910	910	910	910	910	910	910	910	910	910	910
System data (5)												
Nb of refrigerant circuit	#	2	2	2	2	2	2	2	2	2	2	2
Minimum cooling load % (4) (7)	%	15	15	15	15	15	15	15	15	15	15	15
Standard unit												
Refrigerant charge Circuit 1 / Circuit 2	(kg)	90/40	93/44	93/49	90/88	94/91	94/96					
Oil charge Circuit 1 / Circuit 2 (8)	(l)	13/7	13/7	13/7	13/13	13/13	13/13					
POE Oil type (10)					OIL00317 or OIL00315							

- (1) Indicative performance at Evaporator water temperature: 12°C / 7°C - Condenser air temperature 35°C - for detailed performances consult Order Write Up.
- (2) Under 400V/3/50Hz.
- (3) Rated Condition without Pump Package.
- (4) Percent minimum load may be adjusted around 15%-20% according to operating conditions by local sales office.
- (5) Electrical & system data are indicative and subject to change without notice. Please refer to unit nameplate data.
- (6) Not applicable for Glycol application - see tables with Minimum Flow with Glycol.
- (7) Max speed - range is 60% to 100% of max speed.
- (8) Refrigerant charge may vary according to option - for instance +20% for process (digit 19 = p). For real value refer to unit nameplate.
- (9) Data containing information on two circuits shown as follows: ckt1/ckt2.
- (10) OIL0066E or OIL0067E may have been used on early orders and there is no restriction to continue to use them but preferable oil is OIL00315 or OIL00317.

General Data

Table 14a – General Data RTAF 250-450 standard efficiency Extra Low Noise - R134a - R513A

		RTAF 250 SE XLN	RTAF 280 SE XLN	RTAF 310 SE XLN	RTAF 350 SE XLN	RTAF 355 SE XLN	RTAF 380 SE XLN	RTAF 410 SE XLN	RTAF 450 SE XLN
Cooling Capacity (1)	(kW)	858	972	1074	1193	1186	1322	1447	1589
Unit electrical data (2) (3) (5)									
Maximum Power input in cooling	(kW)	371	420	466	522	525	572	621	700
Unit rated amps (Max compr +Fan+Control)	(A)	614	694	772	862	870	946	1030	1163
Unit start up amps (Starting Amps of the largest compr+RLA of 2nd compr+RLA of all fans+ control)	(A)	767	847	886	1015	952	1099	1144	1245
Displacement Power Factor (DPF)		0.87	0.88	0.87	0.88	0.87	0.87	0.87	0.87
Max power cable cross section	(mm ²)	4x185	4x185	4x185	4x185	4x185	4x185	4x185	6x185
Disconnect switch size	(A)	1250	1250	1250	1250	1250	1250	1250	1600
Compressor									
Quantity	#	3	3	3	4	3	4	4	4
Type		Screw	Screw	Screw	Screw	Screw	Screw	Screw	Screw
Model (9)		85-85/70	85-100/85	100-100/100	85-85/ 85-85	115-115/ 115	85-100/ 85-100	100-100/ 100-100	115-115/ 115-115
Max Compr Power input Circuit 1/ Circuit 2	kW	121-121/99	121-144/121	144-144/144	121-121/ 121-121	164-164/ 164	121-144/ 121-144	144-144/ 144-144	164-164/ 164-164
Max Amps Circuit 1 / Circuit 2 (3) (5)	(A)	201-201/166	201-240/201	240-240/240	201-201/ 201-201	273-273/ 273	201-240/ 201-240	240-240/ 240-240	273-273/ 273-273
Start up Amps Circuit 1 / Circuit 2 (3) (5)	(A)	354-354/291	354-354/354	354-354/354	354-354/ 354-354	354-354/ 354	354-354/ 354-354	354-354/ 354-354	354-354/ 354-354
Motor RPM	(rpm)	3000	3000	3000	3000	3000	3000	3000	3000
Oil sump heater Circuit 1 / Circuit 2	(W)	300/150	300/150	300/150	300/300	300/300	300/300	300/300	300/300
Evaporator									
Quantity	#	1	1	1	1	1	1	1	1
Type		Flooded shell and tube heat exchanger							
Evaporator model		300D	300B	300A	500D	300A	500C	500B	500B
Evaporator Water Content volume	(l)	97	108	120	146	120	159	170	170
Antifreeze Heater	(W)	2240	2240	2240	2440	2440	2440	2440	2440
Two pass evaporator									
Evap. Water Flow rate - Minimum	(l/s)	17.7	20.1	22.8	25.0	22.8	27.8	30.3	30.3
Evap. Water Flow rate - Maximum (6)	(l/s)	65.8	74.5	84.8	92.8	84.8	103.0	112.5	112.5
Nominal water connection size (Grooved coupling)	(in) - (DN)	6" - 150	6" - 150	6" - 150	8" - 200	6" - 150	8" - 200	8" - 200	8" - 200
Two pass evaporator with turbulator									
Evap. Water Flow rate - Minimum (6)	(l/s)	14.8	16.7	19.0	20.8	19.0	23.1	25.3	25.3
Evap. Water Flow rate - Maximum	(l/s)	59.1	66.9	76.1	83.4	76.1	92.5	101.1	101.1
Nominal water connection size (Grooved coupling)	(in) - (mm)	6" - 150	6" - 150	6" - 150	8" - 200	6" - 150	8" - 200	8" - 200	8" - 200
Hydraulic Module Components									
Standard head pressure pump option (Twin pump)									
Available Head Pressure (1)	(kPa)	167	118	95	146	82	134	120	80
Max Motor Power input	(kW)	15	15	15	22	15	22	22	22
Max Amps	(A)	28	28	28	39.7	28	39.7	39.7	39.7
High head pressure pump option (Twin Pump)									
Available Head Pressure (1)	(kPa)	223	229	193	NA	175	NA	NA	NA
Max Motor Power input	(kW)	19	22	22	NA	22	NA	NA	NA
Max Amps	(A)	34.5	39.7	39.7	NA	39.7	NA	NA	NA
Expansion Tank Volume	(l)	80	160	160	160	160	160	160	160
Max User water loop Volume for factory mounted expansion tank (1)	(l)	4000	4000	4000	4000	4000	4000	4000	4000
Max. Water-side Operating Pressure without pump package	(kPa)	1000	1000	1000	1000	1000	1000	1000	1000
Max. Water-side Operating Pressure with pump package	(kPa)	450	450	450	450	450	450	450	450
Antifreeze Heater with pump package	(W)	3300	3400	3400	3600	3400	3600	3600	3600
Condenser									
Type		Full aluminum Micro channel heat exchanger							
Quantity	#	10/4	10/6	10/6	10/8	10/6	10/10	12/10	12/10
Face area per coil	(m ²)	2.4	2.4	2.4	2.4	2.4	2.4	2.4	2.4
Condenser Fan									
Quantity	#	10/4	10/6	10/6	10/8	10/6	10/10	12/10	12/10
Diameter	(mm)	800	800	800	800	800	800	800	800
Standard / High ambient fan option									
Fan / motor Type		Propeller fan / Variable Speed - EC motor							
Airflow per Fan	(m ³ /h)	20000	20000	20000	20000	20000	20000	20000	20000
Max Power input per Motor	(kW)	1.1	1.1	1.1	1.1	1.1	1.1	1.1	1.1
Max Amps per Motor	(A)	1.8	1.8	1.8	1.8	1.8	1.8	1.8	1.8
Motor RPM	(rpm)	860	860	860	860	860	860	860	860

General Data

Table 14a – General Data RTAF 250-450 standard efficiency Extra Low Noise - R134a - R513A (continued)

		RTAF 250	RTAF 280	RTAF 310	RTAF 350	RTAF 355	RTAF 380	RTAF 410	RTAF 450
		SE XLN	SE XLN	SE XLN	SE XLN	SE XLN	SE XLN	SE XLN	SE XLN
Low ambient fan option									
Fan / motor Type		Propeller fan			Variable speed - EC motor				
Airflow per Fan	(m ³ /h)	20000	20000	20000	20000	20000	20000	20000	20000
Max Power input per Motor	(kW)	1.10	1.10	1.10	1.10	1.10	1.10	1.10	1.10
Max Amps per Motor	(A)	1.80	1.80	1.80	1.80	1.80	1.80	1.80	1.80
Motor RPM	(rpm)	860	860	860	860	860	860	860	860
System data (5)									
Nb of refrigerant circuit	#	2	2	2	2	2	2	2	2
Minimum cooling load % (4) (7)	%	15	15	15	15	15	15	15	15
R134a/R513A refrigerant charge Circuit 1 / Circuit 2 (8)	(kg)	93/45	96/49	97/52	94/91	97/52	98/100	107/104	107/104
Oil charge Circuit 1 / Circuit 2	(l)	16/8	16/8	16/8	16/16	16/8	16/16	16/16	16/16
POE Oil type		OIL0048E or OIL0023E							

- (1) Indicative performance at Evaporator water temperature: 12°C / 7°C - Condenser air temperature 35°C- for detailed performances consult Order Write Up.
- (2) Under 400V/3/50Hz.
- (3) Rated Condition without Pump Package.
- (4) Percent minimum load may be adjusted around 15%-20% according to operating conditions by local sales office.
- (5) Electrical & system data are indicative and subject to change without notice. Please refer to unit nameplate data.
- (6) Not applicable for Glycol application- see tables with Minimum Flow with Glycol.
- (7) Max speed - range is 60% to 100% of max speed.
- (8) Refrigerant charge may vary according to option - for instance +20% for process (digit 19=P). For real value refer to unit nameplate.
- (9) Data containing information on two circuits shown as follows: ckt1/ckt2.

General Data

Table 14b – General Data RTAF 210-340 standard efficiency Extra Low Noise - R1234 ze

		RTAF 210	RTAF 230	RTAF 265	RTAF 285	RTAF 305	RTAF 340
		SE XLN	SE XLN	SE XLN	SE XLN	SE XLN	SE XLN
Net Cooling Capacity (1)	(kW)	725	806	886	995	1080	1187
Unit electrical data (2) (3) (5)							
Maximum Power input in cooling	(kW)	350	404	408	483	537	541
Unit rated amps (Max compr+Fan+Control)	(A)	576	658	664	792	874	880
Unit start up amps (Starting Amps of the largest compr)	(A)	726	808	814	942	1024	1030
Displacement Power factor (DPF)		0.88	0.89	0.89	0.88	0.89	0.89
Max Power cable cross section	mm ²	4*185	4*185	4*185	4*185	4*185	4*185
Disconnect switch size	(A)	1250	1250	1250	1250	1250	1250
Compressor							
Quantity	#	3	3	3	4	4	4
Type		Screw	Screw	Screw	Screw	Screw	Screw
Model		65-78/65	78-78/78	78-78/78	65-78/65-78	78-78/78-78	78-78/78-78
Max Compr Power input Circuit1 / Circuit2	(kW)	98-125/ 98	125-125/ 125	125-125/ 125	98-125/ 98-125	125-125/ 125-125	125-125/ 125-125
Max Amps Circuit1 / Circuit 2 (3) (5)	(A)	163-204/ 163	204-204/ 204	204-204/ 204	163-204/ 163-204	204-204/ 204-204	204-204/ 204-204
Start up Amps Circuit1 / Circuit 2 (3)(5)	(A)	291-354/ 354	354-354/ 354	354-354/ 354	291-354/ 291-354	354-354/ 354-354	354-354/ 354-354
Motor RPM	(rpm)	3000	3000	3000	3000	3000	3000
Oil sump heater Circuit1 / Circuit 2	(W)	700	700	700	850	850	850
Evaporator							
Quantity	#	1	1	1	1	1	1
Type		Flooded shell and tube heat exchanger					
Evaporator model		300E	300D	300D	500E	500D	500D
Evaporator Water Content volume	(l)	86	97	97	130	146	146
Antifreeze Heater	(W)	2240	2240	2240	2440	2440	2440
Two pass evaporator							
Evap. Water Flow rate - Minimum	(l/s)	15.7	17.7	17.7	22.2	25.0	25.0
Evap. Water Flow rate - Maximum (6)	(l/s)	58.5	65.8	65.8	82.6	92.8	92.8
Nominal water connection size (Grooved coupling)	(in) - (mm)	6" - 150	6" - 150	6" - 150	8" - 200	8" - 200	8" - 201
Two pass evaporator with turbulator							
Evap. Water Flow rate - Minimum	(l/s)	13.2	14.8	14.8	18.5	20.8	20.8
Evap. Water Flow rate - Maximum (6)	(l/s)	52.5	59.1	59.1	74.2	83.4	83.4
Nominal water connection size (Grooved coupling)	(in) - (mm)	6" - 150	6" - 150	6" - 150	8" - 200	8" - 200	8" - 201
Hydraulic Module Components							
Standard head pressure pump option (Twin pump)							
Available Head Pressure (1)	(kPa)	N/A	N/A	N/A	N/A	N/A	N/A
Max. Motor Power Input	(kW)	11.0	11.0	15.0	15.0	15.0	22.0
Max. Rated Amps	(A)	20.8	20.8	29.0	29.0	29.0	39.7
High head pressure pump option (Twin pump)							
Available Head Pressure (1)	(kPa)	N/A	N/A	N/A	N/A	N/A	N/A
Max. Motor Power Input	(kW)	18.5	18.5	22.0	22.0	22.0	0.0
Max. Amps	(A)	34.5	34.5	39.7	39.7	39.7	0.0
Expansion Tank Volume	(l)	N/A	N/A	N/A	N/A	N/A	N/A
Max User water loop Volume for factory mounted expansion tank (1)	(l)	N/A	N/A	N/A	N/A	N/A	N/A
Max. Water-side Operating Pressure without pump package	(kPa)	N/A	N/A	N/A	N/A	N/A	N/A
Max. Water-side Operating Pressure with pump package	(kPa)	N/A	N/A	N/A	N/A	N/A	N/A
Antifreeze Heater with pump package	(W)	3300	3300	3400	3600	3600	3600
Condenser							
Type		Full aluminum Micro channel heat exchanger					
Quantity	#	10/4	10/4	10/6	10/8	10/8	10/10
Face area per coil	(m ²)	2.4	2.4	2.4	2.4	2.4	2.4
Condenser Fan							
Quantity	#	10/4	10/4	10/6	10/8	10/8	10/10
Diameter	(mm)	800	800	800	800	800	800
Standard / High ambient fan option							
Fan / motor Type		Propeller fan / Variable speed - EC motor					
Airflow per Fan	(m ³ /h)	20000	20000	20000	20000	20000	20000
Max Power Input per Motor	(kW)	1.1	1.1	1.1	1.1	1.1	1.1
Max Amps per Motor	(A)	1.8	1.8	1.8	1.8	1.8	1.8
Motor RPM	(rpm)	860	860	860	860	860	860

General Data

Table 14b – General Data RTAF 210-340 standard efficiency Extra Low Noise - R1234 ze (continued)

		RTAF 210	RTAF 230	RTAF 265	RTAF 285	RTAF 305	RTAF 340
		SE XLN	SE XLN	SE XLN	SE XLN	SE XLN	SE XLN
Low ambient fan option							
Fan / motor Type		Propeller fan / Variable speed - EC motor					
Airflow per Fan	(m ³ /h)	20000	20000	20000	20000	20000	20000
Max Power Input per Motor	(kW)	1.1	1.1	1.1	1.1	1.1	1.1
Max Amps per Motor	(A)	1.8	1.8	1.8	1.8	1.8	1.8
Motor RPM	(rpm)	860	860	860	860	860	860
System data (5)							
Nb of refrigerant circuit	#	2	2	2	2	2	2
Minimum cooling load % (4) (7)	%	15	15	15	15	15	15
Refrigerant charge Circuit 1 / Circuit 2	(kg)	90/40	93/44	93/49	90/88	94/91	94/96
Oil charge Circuit 1 / Circuit 2	(l)	13/7	13/7	13/7	13/13	13/13	13/13
POE Oil type (10)		OIL00317 or OIL00315					

(1) Indicative performance at Evaporator water temperature: 12°C / 7°C - Condenser air temperature 35°C - for detailed performances consult Order Write Up.

(2) Under 400V/3/50Hz.

(3) Rated Condition without Pump Package.

(4) Percent minimum load may be adjusted around 15%-20% according to operating conditions by local sales office.

(5) Electrical & system data are indicative and subject to change without notice. Please refer to unit nameplate data.

(6) Not applicable for Glycol application - see tables with Minimum Flow with Glycol.

(7) Max speed - range is 60% to 100% of max speed.

(8) Refrigerant charge may vary according to option - for instance +20% for process (digit 19 = p). For real value refer to unit nameplate.

(9) Data containing information on two circuits shown as follows: ckt1/ckt2.

(10) OIL0066E or OIL0067E may have been used on early orders and there is no restriction to continue to use them but preferable oil is OIL00315 or OIL00317.

General Data

Table 15a – General Data RTAF 250-450 Standard Efficiency - AC Extra Low Noise - R134a - R513A

		RTAF	RTAF	RTAF	RTAF	RTAF	RTAF	RTAF	RTAF
		250	280	310	350	355	380	410	450
		SE AC XLN	SE AC XLN	SE AC XLN	SE AC XLN	SE AC XLN	SE AC XLN	SE AC XLN	SE AC XLN
Cooling Capacity (1)	(kW)	848	960	1060	1177	1166	1305	1428	1582
Unit electrical data (2) (3) (5)									
Maximum Power input in cooling	(kW)	363	412	457	513	516	562	610	689
Unit rated amps (Max compr +Fan+Control)	(A)	612	692	770	860	868	944	1027	1160
Unit start up amps (Starting Amps of the largest compr+RLA of 2nd compr+RLA of all fans+ control)	(A)	765	845	884	1013	950	1097	1141	1242
Displacement Power Factor (DPF)		0.86	0.86	0.86	0.86	0.86	0.86	0.86	0.86
Max power cable cross section	(mm ²)	4x185	4x185	4x185	4x185	4x185	4x185	4x185	6x185
Disconnect switch size	(A)	1250	1250	1250	1250	1250	1250	1250	1600
Compressor									
Quantity	#	3	3	3	4	3	4	4	4
Type		Screw	Screw	Screw	Screw	Screw	Screw	Screw	Screw
Model (9)		85-85/70	85-100/85	100-100/100	85-85/85-85	115-115/115	85-100/85-100	100-100/100-100	115-115/115-115
Max Compr Power input Circuit 1/ Circuit 2	kW	121-121/99	121-144/121	144-144/144	121-121/121-121	164-164/164	121-144/121-144	144-144/144-144	164-164/164-164
Max Amps Circuit 1 / Circuit 2 (3) (5)	(A)	201-201/166	201-240/201	240-240/240	201-201/201-201	273-273/273	201-240/201-240	240-240/240-240	273-273/273-273
Start up Amps Circuit 1 / Circuit 2 (3) (5)	(A)	354-354/291	354-354/354	354-354/354	354-354/354-354	354-354/354	354-354/354-354	354-354/354-354	354-354/354-354
Motor RPM	(rpm)	3000	3000	3000	3000	3000	3000	3000	3000
Oil sump heater Circuit 1 / Circuit 2	(W)	300/150	300/150	300/150	300/300	300/300	300/300	300/300	300/300
Evaporator									
Quantity	#	1	1	1	1	1	1	1	1
Type		Flooded shell and tube heat exchanger							
Evaporator model		300D	300B	300A	500D	300A	500C	500B	500B
Evaporator Water Content volume	(l)	97	108	120	146	120	159	170	170
Antifreeze Heater	(W)	2240	2240	2240	2440	2440	2440	2440	2440
Two pass evaporator									
Evap. Water Flow rate - Minimum	(l/s)	17.7	20.1	22.8	25.0	22.8	27.8	30.3	30.3
Evap. Water Flow rate - Maximum (6)	(l/s)	65.8	74.5	84.8	92.8	84.8	103.0	112.5	112.5
Nominal water connection size (Grooved coupling)	(in) - (DN)	6" - 150	6" - 150	6" - 150	8" - 200	6" - 150	8" - 200	8" - 200	8" - 200
Two pass evaporator with turbulator									
Evap. Water Flow rate - Minimum (6)	(l/s)	14.8	16.7	19.0	20.8	19.0	23.1	25.3	25.3
Evap. Water Flow rate - Maximum	(l/s)	59.1	66.9	76.1	83.4	76.1	92.5	101.1	101.1
Nominal water connection size (Grooved coupling)	(in) - (mm)	6" - 150	6" - 150	6" - 150	8" - 200	6" - 150	8" - 200	8" - 200	8" - 200
Hydraulic Module Components									
Standard head pressure pump option (Twin pump)									
Available Head Pressure (1)	(kPa)	167	118	95	146	82	134	120	80
Max Motor Power input	(kW)	15	15	15	22	15	22	22	22
Max Amps	(A)	28	28	28	39.7	28	39.7	39.7	39.7
High head pressure pump option (Twin Pump)									
Available Head Pressure (1)	(kPa)	223	229	193	NA	175	NA	NA	NA
Max Motor Power input	(kW)	19	22	22	NA	22	NA	NA	NA
Max Amps	(A)	34.5	39.7	39.7	NA	39.7	NA	NA	NA
Expansion Tank Volume	(l)	80	160	160	160	160	160	160	160
Max User water loop Volume for factory mounted expansion tank (1)	(l)	4000	4000	4000	4000	4000	4000	4000	4000
Max. Water-side Operating Pressure without pump package	(kPa)	1000	1000	1000	1000	1000	1000	1000	1000
Max. Water-side Operating Pressure with pump package	(kPa)	450	450	450	450	450	450	450	450
Antifreeze Heater with pump package	(W)	3300	3400	3400	3600	3400	3600	3600	3600
Condenser									
Type		Full aluminum Micro channel heat exchanger							
Quantity	#	10/4	10/6	10/6	10/8	10/6	10/10	12/10	12/10
Face area per coil	(m ²)	2.4	2.4	2.4	2.4	2.4	2.4	2.4	2.4
Condenser Fan									
Quantity	#	10/4	10/6	10/6	10/8	10/6	10/10	12/10	12/10
Diameter	(mm)	800	800	800	800	800	800	800	800
Standard / High ambient fan option									
Fan / motor Type		Propeller fan / Variable Speed - EC motor							
Airflow per Fan	(m ³ /h)	18000	18000	18000	18000	18000	18000	18000	18000
Max Power input per Motor	(kW)	1.2	1.2	1.2	1.2	1.2	1.2	1.2	1.2
Max Amps per Motor	(A)	2.9	2.9	2.9	2.9	2.9	2.9	2.9	2.9
Motor RPM	(rpm)	900	900	900	900	900	900	900	900

General Data

Table 15a – General Data RTAF 250-450 Standard Efficiency - AC Extra Low Noise - R134a - R513A (continued)

		RTAF 250	RTAF 280	RTAF 310	RTAF 350	RTAF 355	RTAF 380	RTAF 410	RTAF 450
		SE AC XLN	SE AC XLN	SE AC XLN	SE AC XLN	SE AC XLN	SE AC XLN	SE AC XLN	SE AC XLN
Low ambient fan option									
Fan / motor Type		Propeller fan / Fix speed - AC motor							
Airflow per Fan	(m ³ /h)	18000	18000	18000	18000	18000	18000	18000	18000
Max Power input per Motor	(kW)	1.2	1.2	1.2	1.2	1.2	1.2	1.2	1.2
Max Amps per Motor	(A)	2.9	2.9	2.9	2.9	2.9	2.9	2.9	2.9
Motor RPM	(rpm)	900	900	900	900	900	900	900	900
System data (5)									
Nb of refrigerant circuit	#	2	2	2	2	2	2	2	2
Minimum cooling load % (4) (7)	%	15	15	15	15	15	15	15	15
R134a/R513A refrigerant charge Circuit 1 / Circuit 2 (8)	(kg)	93/45	96/49	97/52	94/91	97/52	98/100	107/104	107/104
Oil charge Circuit 1 / Circuit 2	(l)	16/8	16/8	16/8	16/16	16/8	16/16	16/16	16/16
POE Oil type		OIL0048E or OIL0023E							

- (1) Indicative performance at Evaporator water temperature: 12°C / 7°C - Condenser air temperature 35°C- for detailed performances consult Order Write Up.
- (2) Under 400V/3/50Hz.
- (3) Rated Condition without Pump Package.
- (4) Percent minimum load may be adjusted around 15%-20% according to operating conditions by local sales office.
- (5) Electrical & system data are indicative and subject to change without notice. Please refer to unit nameplate data.
- (6) Not applicable for Glycol application- see tables with Minimum Flow with Glycol.
- (7) Max speed - range is 60% to 100% of max speed.
- (8) Refrigerant charge may vary according to option - for instance +20% for process (digit 19=P). For real value refer to unit nameplate.
- (9) Data containing information on two circuits shown as follows: ckt1/ckt2.

General Data

Table 15b – General Data RTAF 210-340 Standard Efficiency - AC Extra Low Noise - R1234 ze

		RTAF	RTAF	RTAF	RTAF	RTAF	RTAF
		210	230	265	285	305	340
		SE AC XLN	SE AC XLN	SE AC XLN	SE AC XLN	SE AC XLN	SE AC XLN
Net Cooling Capacity (1)	(kW)	720	799	882	987	1070	1180
Unit electrical data (2) (3) (5)							
Maximum Power input in cooling	(kW)	343	397	400	474	528	531
Unit rated amps (Max compr+Fan+Control)	(A)	575	657	662	790	872	878
Unit start up amps (Starting Amps of the largest compr)	(A)	725	807	812	940	1022	1028
Displacement Power factor (DPF)		0.86	0.88	0.87	0.87	0.88	0.88
Max Power cable cross section	mm ²	4*185	4*185	4*185	4*185	4*185	4*185
Disconnect switch size	(A)	1250	1250	1250	1250	1250	1250
Compressor							
Quantity	#	3	3	3	4	4	4
Type		Screw	Screw	Screw	Screw	Screw	Screw
Model		65-78/65	78-78/78	78-78/78	65-78/65-78	78-78/78-78	78-78/78-78
Max Compr Power input Circuit1 / Circuit2	(kW)	98-125/ 98	125-125/ 125	125-125/ 125	98-125/ 98-125	125-125/ 125-125	125-125/ 125-125
Max Amps Circuit1 / Circuit 2 (3) (5)	(A)	163-204/ 163	204-204/ 204	204-204/ 204	163-204/ 163-204	204-204/ 204-204	204-204/ 204-204
Start up Amps Circuit1 / Circuit 2 (3)(5)	(A)	291-354/ 354	354-354/ 354	354-354/ 354	291-354/ 291-354	354-354/ 354-354	354-354/ 354-354
Motor RPM	(rpm)	3000	3000	3000	3000	3000	3000
Oil sump heater Circuit1 / Circuit 2	(W)	700	700	700	850	850	850
Evaporator							
Quantity	#	1	1	1	1	1	1
Type		Flooded shell and tube heat exchanger					
Evaporator model		300E	300D	300D	500E	500D	500D
Evaporator Water Content volume	(l)	86	97	97	130	146	146
Antifreeze Heater	(W)	2240	2240	2240	2440	2440	2440
Two pass evaporator							
Evap. Water Flow rate - Minimum	(l/s)	15.7	17.7	17.7	22.2	25.0	25.0
Evap. Water Flow rate - Maximum (6)	(l/s)	58.5	65.8	65.8	82.6	92.8	92.8
Nominal water connection size (Grooved coupling)	(in) - (mm)	6" - 150	6" - 150	6" - 150	8" - 200	8" - 200	8" - 201
Two pass evaporator with turbulator							
Evap. Water Flow rate - Minimum	(l/s)	13.2	14.8	14.8	18.5	20.8	20.8
Evap. Water Flow rate - Maximum (6)	(l/s)	52.5	59.1	59.1	74.2	83.4	83.4
Nominal water connection size (Grooved coupling)	(in) - (mm)	6" - 150	6" - 150	6" - 150	8" - 200	8" - 200	8" - 201
Hydraulic Module Components							
Standard head pressure pump option (Twin pump)							
Available Head Pressure (1)	(kPa)	N/A	N/A	N/A	N/A	N/A	N/A
Max. Motor Power Input	(kW)	11.0	11.0	15.0	15.0	15.0	22.0
Max. Rated Amps	(A)	20.8	20.8	29.0	29.0	29.0	39.7
High head pressure pump option (Twin pump)							
Available Head Pressure (1)	(kPa)	N/A	N/A	N/A	N/A	N/A	N/A
Max. Motor Power Input	(kW)	18.5	18.5	22.0	22.0	22.0	0.0
Max. Amps	(A)	34.5	34.5	39.7	39.7	39.7	0.0
Expansion Tank Volume	(l)	N/A	N/A	N/A	N/A	N/A	N/A
Max User water loop Volume for factory mounted expansion tank (1)	(l)	N/A	N/A	N/A	N/A	N/A	N/A
Max. Water-side Operating Pressure without pump package	(kPa)	N/A	N/A	N/A	N/A	N/A	N/A
Max. Water-side Operating Pressure with pump package	(kPa)	N/A	N/A	N/A	N/A	N/A	N/A
Antifreeze Heater with pump package	(W)	3300	3300	3400	3600	3600	3600
Condenser							
Type		Full aluminum Micro channel heat exchanger					
Quantity	#	10/4	10/4	10/6	10/8	10/8	10/10
Face area per coil	(m ²)	2.4	2.4	2.4	2.4	2.4	2.4
Condenser Fan							
Quantity	#	10/4	10/4	10/6	10/8	10/8	10/10
Diameter	(mm)	800	800	800	800	800	800
Standard / High ambient fan option							
Fan / motor Type		Propeller fan / Variable speed - EC motor					
Airflow per Fan	(m ³ /h)	18000	18000	18000	18000	18000	18000
Max Power Input per Motor	(kW)	1.2	1.2	1.2	1.2	1.2	1.2
Max Amps per Motor	(A)	2.9	2.9	2.9	2.9	2.9	2.9
Motor RPM	(rpm)	900	900	900	900	900	900

General Data

Table 15b – General Data RTAF 210-340 Standard Efficiency - AC Extra Low Noise - R1234 ze (continued)

		RTAF 210	RTAF 230	RTAF 265	RTAF 285	RTAF 305	RTAF 340
		SE AC XLN	SE AC XLN	SE AC XLN	SE AC XLN	SE AC XLN	SE AC XLN
Low ambient fan option							
Fan / motor Type		Propeller fan / Variable speed - EC motor					
Airflow per Fan	(m ³ /h)	20000	20000	20000	20000	20000	20000
Max Power Input per Motor	(kW)	1.1	1.1	1.1	1.1	1.1	1.1
Max Amps per Motor	(A)	1.8	1.8	1.8	1.8	1.8	1.8
Motor RPM	(rpm)	860	860	860	860	860	860
System data (5)							
Nb of refrigerant circuit	#	2	2	2	2	2	2
Minimum cooling load % (4) (7)	%	15	15	15	15	15	15
Refrigerant charge Circuit 1 / Circuit 2	(kg)	90/40	93/44	93/49	90/88	94/91	94/96
Oil charge Circuit 1 / Circuit 2	(l)	13/7	13/7	13/7	13/13	13/13	13/13
POE Oil type (10)		OIL00317 or OIL00315					

(1) Indicative performance at Evaporator water temperature: 12°C / 7°C - Condenser air temperature 35°C - for detailed performances consult Order Write Up.

(2) Under 400V/3/50Hz.

(3) Rated Condition without Pump Package.

(4) Percent minimum load may be adjusted around 15%-20% according to operating conditions by local sales office.

(5) Electrical & system data are indicative and subject to change without notice. Please refer to unit nameplate data.

(6) Not applicable for Glycol application - see tables with Minimum Flow with Glycol.

(7) Max speed - range is 60% to 100% of max speed.

(8) Refrigerant charge may vary according to option - for instance +20% for process (digit 19 = p). For real value refer to unit nameplate.

(9) Data containing information on two circuits shown as follows: ckt1/ckt2.

(10) OIL0066E or OIL0067E may have been used on early orders and there is no restriction to continue to use them but preferable oil is OIL00315 or OIL00317.

General Data

Table 16a – General Data RTAF 250-450 High Efficiency - Standard and Low Noise - R134a - R513A

		RTAF	RTAF	RTAF	RTAF	RTAF	RTAF	RTAF	RTAF
		250	280	310	350	355	380	410	450
		HE SN LN	HE SN LN	HE SN LN	HE SN LN	HE SN LN	HE SN LN	HE SN LN	HE SN LN
Cooling Capacity (1)	(kW)	872	986	1102	1233	1214	1352	1456	1605
Unit electrical data (2) (3) (5)									
Maximum Power input in cooling	(kW)	373	422	482	528	541	577	623	702
Unit rated amps (Max compr +Fan+Control)	(A)	636	718	828	896	926	982	1060	1193
Unit start up amps (Starting Amps of the largest compr+RLA of 2nd compr+RLA of all fans+ control)	(A)	789	871	942	1049	1008	1135	1174	1275
Displacement Power Factor (DPF)		0.85	0.85	0.85	0.86	0.85	0.85	0.85	0.85
Max power cable cross section	(mm ²)	4x185	4x185	4x185	4x185	4x185	4x185	4x185	6x185
Disconnect switch size	(A)	1250	1250	1250	1250	1250	1250	1250	1600
Compressor									
Quantity	#	3	3	3	4	3	4	4	4
Type		Screw	Screw	Screw	Screw	Screw	Screw	Screw	Screw
Model (9)		85-85/70	85-100/85	100-100/100	85-85/85-85	115-115/115	85-100/85-100	100-100/100-100	115-115/115-115
Max Compr Power input Circuit 1/ Circuit 2	(kW)	121-121/99	121-144/121	144-144/144	121-121/121-121	164-164/164	121-144/121-144	144-144/144-144	164-164/164-164
Max Amps Circuit 1 / Circuit 2 (3) (5)	(A)	201-201/166	201-240/201	240-240/240	201-201/201-201	273-273/273	201-240/201-240	240-240/240-240	273-273/273-273
Start up Amps Circuit 1 / Circuit 2 (3) (5)	(A)	354-354/291	354-354/354	354-354/354	354-354/354-354	354-354/354	354-354/354-354	354-354/354-354	354-354/354-354
Motor RPM	(rpm)	3000	3000	3000	3000	3000	3000	3000	3000
Oil sump heater Circuit 1 / Circuit 2	(W)	300/150	300/150	300/150	300/300	300/300	300/300	300/300	300/300
Evaporator									
Quantity	#	1	1	1	1	1	1	1	1
Type		Flooded shell and tube heat exchanger							
Evaporator model		300D	300B	300A	500D	300A	500C	500B	500B
Evaporator Water Content volume	(l)	97	108	120	146	120	159	170	170
Antifreeze Heater	(W)	2240	2240	2240	2440	2440	2440	2440	2440
Two pass evaporator									
Evap. Water Flow rate - Minimum	(l/s)	17.7	20.1	22.8	25.0	22.8	27.8	30.3	30.3
Evap. Water Flow rate - Maximum (6)	(l/s)	65.8	74.5	84.8	92.8	84.8	103.0	112.5	112.5
Nominal water connection size (Grooved coupling)	(in) - (DN)	6" - 150	6" - 150	6" - 150	8" - 200	6" - 150	8" - 200	8" - 200	8" - 200
Two pass evaporator with turbulator									
Evap. Water Flow rate - Minimum (6)	(l/s)	14.8	16.7	19.0	20.8	19.0	23.1	25.3	25.3
Evap. Water Flow rate - Maximum	(l/s)	59.1	66.9	76.1	83.4	76.1	92.5	101.1	101.1
Nominal water connection size (Grooved coupling)	(in) - (mm)	6" - 150	6" - 150	6" - 150	8" - 200	6" - 150	8" - 200	8" - 200	8" - 200
Hydraulic Module Components									
Standard head pressure pump option (Twin pump)									
Available Head Pressure (1)	(kPa)	160	106	115	139	82	127	116	77
Max Motor Power input	(kW)	15	15	15	22	15	22	22	22
Max Amps	(A)	28	28	28	39.7	28	39.7	39.7	39.7
High head pressure pump option (Twin Pump)									
Available Head Pressure (1)	(kPa)	216	220	174	NA	175	NA	NA	NA
Max Motor Power input	(kW)	19	22	22	NA	22	NA	NA	NA
Max Amps	(A)	34.5	39.7	39.7	NA	39.7	NA	NA	NA
Expansion Tank Volume	(l)	80	160	160	160	160	160	160	160
Max User water loop Volume for factory mounted expansion tank (1)	(l)	4000	8000	8000	8000	8000	8000	8000	8000
Max. Water-side Operating Pressure without pump package	(kPa)	1000	1000	1000	1000	1000	1000	1000	1000
Max. Water-side Operating Pressure with pump package	(kPa)	450	450	450	450	450	450	450	450
Antifreeze Heater with pump package	(W)	3300	3400	3400	3600	3400	3600	3600	3600
Condenser									
Type		Full aluminum Micro channel heat exchanger							
Quantity	#	12/4	12/6	14/6	12/10	14/6	12/12	12/12	12/12
Face area per coil	(m ²)	2.4	2.4	2.4	2.4	2.4	2.4	2.4	2.4
Condenser Fan									
Quantity	#	12/4	12/6	14/6	12/10	14/6	12/12	12/12	12/12
Diameter	(mm)	800	800	800	800	800	800	800	800
Standard / High ambient fan option									
Fan / motor Type		Propeller fan / Fix Speed - AC motor							
Airflow per Fan	(m ³ /h)	20000	20000	20000	20000	20000	20000	20000	20000
Max Power input per Motor	(kW)	1.4	1.4	1.4	1.4	1.4	1.4	1.4	1.4
Max Amps per Motor	(A)	3.4	3.4	3.4	3.4	3.4	3.4	3.4	3.4
Motor RPM	(rpm)	932	932	932	932	932	932	932	932

General Data

Table 16a – General Data RTAF 250-450 High Efficiency - Standard and Low Noise - R134a - R513A (continued)

		RTAF 250	RTAF 280	RTAF 310	RTAF 350	RTAF 355	RTAF 380	RTAF 410	RTAF 450
		HE SN LN	HE SN LN	HE SN LN	HE SN LN	HE SN LN	HE SN LN	HE SN LN	HE SN LN
Low ambient fan option									
Fan / motor Type		Propeller fan / Fix Speed - EC motor							
Airflow per Fan	(m ³ /h)	20000	20000	20000	20000	20000	20000	20000	20000
Max Power input per Motor	(kW)	2.0	2.0	2.0	2.0	2.0	2.0	2.0	2.0
Max Amps per Motor	(A)	3	3	3	3	3	3	3	3
Motor RPM	(rpm)	860	860	860	860	860	860	860	860
System data (5)									
Nb of refrigerant circuit	#	2	2	2	2	2	2	2	2
Minimum cooling load % (4) (7)	%	15	15	15	15	15	15	15	15
R134a/R513A refrigerant charge Circuit 1 / Circuit 2 (8)	(kg)	108/43	104/53	112/54	102/96	112/54	103/108	107/110	107/110
Oil charge Circuit 1 / Circuit 2	(l)	16/8	16/8	16/8	16/16	16/8	16/16	16/16	16/16
POE Oil type		OIL0048E or OIL0023E							

- (1) Indicative performance at Evaporator water temperature: 12°C / 7°C - Condenser air temperature 35°C- for detailed performances consult Order Write Up.
- (2) Under 400V/3/50Hz.
- (3) Rated Condition without Pump Package.
- (4) Percent minimum load may be adjusted around 15%-20% according to operating conditions by local sales office.
- (5) Electrical & system data are indicative and subject to change without notice. Please refer to unit nameplate data.
- (6) Not applicable for Glycol application- see tables with Minimum Flow with Glycol.
- (7) Max speed - range is 60% to 100% of max speed.
- (8) Refrigerant charge may vary according to option- for instance +20% for process (digit 19=P). For real value refer to unit nameplate.
- (9) Data containing information on two circuits shown as follows: ckt1/ckt2.

General Data

Table 16b – General Data RTAF 210-340 High Efficiency - Standard and Low Noise - R1234 ze

		RTAF	RTAF	RTAF	RTAF	RTAF	RTAF
		210	230	265	285	305	340
		HE SN LN	HE SN LN	HE SN LN	HE SN LN	HE SN LN	HE SN LN
Net Cooling Capacity (1)	(kW)	726	820	892	1006	1094	1201
Unit electrical data (2) (3) (5)							
Maximum Power input in cooling	(kW)	352	410	410	489	543	546
Unit rated amps (Max compr+Fan+Control)	(A)	598	688	688	826	908	916
Unit start up amps (Starting Amps of the largest compr)	(A)	748	838	838	976	1058	1066
Displacement Power factor (DPF)		0.86	0.87	0.87	0.86	0.87	0.87
Max Power cable cross section	mm ²	4*185	4*185	4*185	4*185	4*185	4*185
Disconnect switch size	(A)	1250	1250	1250	1250	1250	1250
Compressor							
Quantity	#	3	3	3	4	4	4
Type		Screw	Screw	Screw	Screw	Screw	Screw
Model		65-78/65	78-78/78	78-78/78	65-78/65-78	78-78/78-78	78-78/78-78
Max Compr Power input Circuit1 / Circuit2	(kW)	98-125/ 98	125-125/ 125	125-125/ 125	98-125/ 98-125	125-125/ 125-125	125-125/ 125-125
Max Amps Circuit1 / Circuit 2 (3) (5)	(A)	163-204/ 163	204-204/ 204	204-204/ 204	163-204/ 163-204	204-204/ 204-204	204-204/ 204-204
Start up Amps Circuit1 / Circuit 2 (3)(5)	(A)	291-354/ 354	354-354/ 354	354-354/ 354	291-354/ 291-354	354-354/ 354-354	354-354/ 354-354
Motor RPM	(rpm)	3000	3000	3000	3000	3000	3000
Oil sump heater Circuit1 / Circuit 2	(W)	700	700	700	850	850	850
Evaporator							
Quantity	#	1	1	1	1	1	1
Type		Flooded shell and tube heat exchanger					
Evaporator model		300E	300D	300D	500E	500D	500D
Evaporator Water Content volume	(l)	86	97	97	130	146	146
Antifreeze Heater	(W)	2240	2240	2240	2440	2440	2440
Two pass evaporator							
Evap. Water Flow rate - Minimum	(l/s)	15.7	17.7	17.7	22.2	25.0	25.0
Evap. Water Flow rate - Maximum (6)	(l/s)	58.5	65.8	65.8	82.6	92.8	92.8
Nominal water connection size (Grooved coupling)	(in) - (mm)	6" - 150	6" - 150	6" - 150	8" - 200	8" - 200	8" - 201
Two pass evaporator with turbulator							
Evap. Water Flow rate - Minimum	(l/s)	13.2	14.8	14.8	18.5	20.8	20.8
Evap. Water Flow rate - Maximum (6)	(l/s)	52.5	59.1	59.1	74.2	83.4	83.4
Nominal water connection size (Grooved coupling)	(in) - (mm)	6" - 150	6" - 150	6" - 150	8" - 200	8" - 200	8" - 201
Hydraulic Module Components							
Standard head pressure pump option (Twin pump)							
Available Head Pressure (1)	(kPa)	N/A	N/A	N/A	N/A	N/A	N/A
Max. Motor Power Input	(kW)	11.0	11.0	15.0	15.0	15.0	22.0
Max. Rated Amps	(A)	20.8	20.8	29.0	29.0	29.0	39.7
High head pressure pump option (Twin pump)							
Available Head Pressure (1)	(kPa)	N/A	N/A	N/A	N/A	N/A	N/A
Max. Motor Power Input	(kW)	18.5	18.5	22.0	22.0	22.0	0.0
Max. Amps	(A)	34.5	34.5	39.7	39.7	39.7	0.0
Expansion Tank Volume	(l)	N/A	N/A	N/A	N/A	N/A	N/A
Max User water loop Volume for factory mounted expansion tank (1)	(l)	N/A	N/A	N/A	N/A	N/A	N/A
Max. Water-side Operating Pressure without pump package	(kPa)	N/A	N/A	N/A	N/A	N/A	N/A
Max. Water-side Operating Pressure with pump package	(kPa)	N/A	N/A	N/A	N/A	N/A	N/A
Antifreeze Heater with pump package	(W)	3300	3300	3400	3600	3600	3600
Condenser							
Type		Full aluminum Micro channel heat exchanger					
Quantity	#	12/4	12/6	12/6	12/10	12/10	12/12
Face area per coil	(m ²)	2.4	2.4	2.4	2.4	2.4	2.4
Condenser Fan							
Quantity	#	12/4	12/6	12/6	12/10	12/10	12/12
Diameter	(mm)	800	800	800	800	800	800
Standard / High ambient fan option							
Fan / motor Type		Propeller fan / Fixed speed - AC motor					
Airflow per Fan	(m ³ /h)	20000	20000	20000	20000	20000	20000
Max Power Input per Motor	(kW)	1.4	1.4	1.4	1.4	1.4	1.4
Max Amps per Motor	(A)	3.4	3.4	3.4	3.4	3.4	3.4
Motor RPM	(rpm)	932	932	932	932	932	932

General Data

Table 16b – General Data RTAF 210-340 High Efficiency - Standard and Low Noise - R1234 ze (continued)

	RTAF 210		RTAF 230		RTAF 265		RTAF 285		RTAF 305		RTAF 340	
	HE	SN LN	HE	SN LN	HE	SN LN	HE	SN LN	HE	SN LN	HE	SN LN
Low ambient fan option												
Fan / motor Type	Propeller fan / Variable speed - EC motor											
Airflow per Fan	(m ³ /h)	20000	20000	20000	20000	20000	20000	20000	20000	20000	20000	20000
Max Power Input per Motor	(kW)	1.1	1.1	1.1	1.1	1.1	1.1	1.1	1.1	1.1	1.1	1.1
Max Amps per Motor	(A)	1.8	1.8	1.8	1.8	1.8	1.8	1.8	1.8	1.8	1.8	1.8
Motor RPM	(rpm)	860	860	860	860	860	860	860	860	860	860	860
System data (5)												
Nb of refrigerant circuit	#	2	2	2	2	2	2	2	2	2	2	2
Minimum cooling load % (4) (7)	%	15	15	15	15	15	15	15	15	15	15	15
Refrigerant charge Circuit 1 / Circuit 2	(kg)	98/40	104/49	104/49	100/92	102/96	102/102					
Oil charge Circuit 1 / Circuit 2	(l)	13/7	13/7	13/7	13/13	13/13	13/13					
POE Oil type (10)		OIL00317 or OIL00315										

(1) Indicative performance at Evaporator water temperature: 12°C / 7°C - Condenser air temperature 35°C - for detailed performances consult Order Write Up.

(2) Under 400V/3/50Hz.

(3) Rated Condition without Pump Package.

(4) Percent minimum load may be adjusted around 15%-20% according to operating conditions by local sales office.

(5) Electrical & system data are indicative and subject to change without notice. Please refer to unit nameplate data.

(6) Not applicable for Glycol application - see tables with Minimum Flow with Glycol.

(7) Max speed - range is 60% to 100% of max speed.

(8) Refrigerant charge may vary according to option - for instance +20% for process (digit 19 = p). For real value refer to unit nameplate.

(9) Data containing information on two circuits shown as follows: ckt1/ckt2.

(10) OIL0066E or OIL0067E may have been used on early orders and there is no restriction to continue to use them but preferable oil is OIL00315 or OIL00317.

General Data

Table 17a – General Data RTAF 250-450 High Efficiency - AC Extra Low Noise - R134a - R513A

		RTAF 250	RTAF 280	RTAF 310	RTAF 350	RTAF 355	RTAF 380	RTAF 410	RTAF 450
		HE AC XLN	HE AC XLN	HE AC XLN	HE AC XLN	HE AC XLN	HE AC XLN	HE AC XLN	HE AC XLN
Cooling Capacity (1)	(kW)	864	978	1093	1222	1211	1341	1442	1600
Unit electrical data (2) (3) (5)									
Maximum Power input in cooling	(kW)	366	414	472	519	531	567	613	692
Unit rated amps (Max compr +Fan+Control)	(A)	618	698	799	871	897	955	1033	1166
Unit start up amps (Starting Amps of the largest compr+RLA of 2nd compr+RLA of all fans+ control)	(A)	771	851	913	1024	979	1108	1147	1248
Displacement Power Factor (DPF)		0.86	0.86	0.86	0.86	0.86	0.86	0.86	0.86
Max power cable cross section	(mm ²)	4x185	4x185	4x185	4x185	4x185	4x185	4x185	6x185
Disconnect switch size	(A)	1250	1250	1250	1250	1250	1250	1250	1600
Compressor									
Quantity	#	3	3	3	4	3	4	4	4
Type		Screw	Screw	Screw	Screw	Screw	Screw	Screw	Screw
Model (9)		85-85/70	85-100/85	100-100/100	85-85/ 85-85	115-115/ 115	85-100/ 85-100	100-100/ 100-100	115-115/ 115-115
Max Compr Power input Circuit 1/ Circuit 2	kW	121-121/99	121-144/121	144-144/144	121-121/ 121-121	164-164/ 164	121-144/ 121-144	144-144/ 144-144	164-164/ 164-164
Max Amps Circuit 1 / Circuit 2 (3) (5)	(A)	201-201/166	201-240/201	240-240/240	201-201/ 201-201	273-273/ 273	201-240/ 201-240	240-240/ 240-240	273-273/ 273-273
Start up Amps Circuit 1 / Circuit 2 (3) (5)	(A)	354-354/291	354-354/354	354-354/354	354-354/ 354-354	354-354/ 354	354-354/ 354-354	354-354/ 354-354	354-354/ 354-354
Motor RPM	(rpm)	3000	3000	3000	3000	3000	3000	3000	3000
Oil sump heater Circuit 1 / Circuit 2	(W)	300/150	300/150	300/150	300/300	300/300	300/300	300/300	300/300
Evaporator									
Quantity	#	1	1	1	1	1	1	1	1
Type		Flooded shell and tube heat exchanger							
Evaporator model		300D	300B	300A	500D	300A	500C	500B	500B
Evaporator Water Content volume	(l)	97	108	120	146	120	159	170	170
Antifreeze Heater	(W)	2240	2240	2240	2440	2440	2440	2440	2440
Two pass evaporator									
Evap. Water Flow rate - Minimum	(l/s)	17.7	20.1	22.8	25.0	22.8	27.8	30.3	30.3
Evap. Water Flow rate - Maximum (6)	(l/s)	65.8	74.5	84.8	92.8	84.8	103.0	112.5	112.5
Nominal water connection size (Grooved coupling)	(in) - (DN)	6" - 150	6" - 150	6" - 150	8" - 200	6" - 150	8" - 200	8" - 200	8" - 200
Two pass evaporator with turbulator									
Evap. Water Flow rate - Minimum (6)	(l/s)	14.8	16.7	19.0	20.8	19.0	23.1	25.3	25.3
Evap. Water Flow rate - Maximum	(l/s)	59.1	66.9	76.1	83.4	76.1	92.5	101.1	101.1
Nominal water connection size (Grooved coupling)	(in) - (mm)	6" - 150	6" - 150	6" - 150	8" - 200	6" - 150	8" - 200	8" - 200	8" - 200
Hydraulic Module Components									
Standard head pressure pump option (Twin pump)									
Available Head Pressure (1)	(kPa)	160	106	115	139	82	127	116	77
Max Motor Power input	(kW)	15	15	15	22	15	22	22	22
Max Amps	(A)	28	28	28	39.7	28	39.7	39.7	39.7
High head pressure pump option (Twin Pump)									
Available Head Pressure (1)	(kPa)	216	220	174	NA	175	NA	NA	NA
Max Motor Power input	(kW)	19	22	22	NA	22	NA	NA	NA
Max Amps	(A)	34.5	39.7	39.7	NA	39.7	NA	NA	NA
Expansion Tank Volume	(l)	80	160	160	160	160	160	160	160
Max User water loop Volume for factory mounted expansion tank (1)	(l)	4000	8000	8000	8000	8000	8000	8000	8000
Max. Water-side Operating Pressure without pump package	(kPa)	1000	1000	1000	1000	1000	1000	1000	1000
Max. Water-side Operating Pressure with pump package	(kPa)	450	450	450	450	450	450	450	450
Antifreeze Heater with pump package	(W)	3300	3400	3400	3600	3400	3600	3600	3600
Condenser									
Type		Full aluminum Micro channel heat exchanger							
Quantity	#	12/4	12/6	14/6	12/10	14/6	12/12	12/12	12/12
Face area per coil	(m ²)	2.4	2.4	2.4	2.4	2.4	2.4	2.4	2.4
Condenser Fan									
Quantity	#	12/4	12/6	14/6	12/10	14/6	12/12	12/12	12/12
Diameter	(mm)	800	800	800	800	800	800	800	800
Standard / High ambient fan option									
Fan / motor Type		Propeller fan / Fix Speed - AC motor							
Airflow per Fan	(m ³ /h)	18000	18000	18000	18000	18000	18000	18000	18000
Max Power input per Motor	(kW)	1.2	1.2	1.2	1.2	1.2	1.2	1.2	1.2
Max Amps per Motor	(A)	2.9	2.9	2.9	2.9	2.9	2.9	2.9	2.9
Motor RPM	(rpm)	900	900	900	900	900	900	900	900

General Data

Table 17a – General Data RTAF 250-450 High Efficiency - AC Extra Low Noise - R134a - R513A (continued)

		RTAF 250	RTAF 280	RTAF 310	RTAF 350	RTAF 355	RTAF 380	RTAF 410	RTAF 450
		HE AC XLN	HE AC XLN	HE AC XLN	HE AC XLN	HE AC XLN	HE AC XLN	HE AC XLN	HE AC XLN
Low ambient fan option									
Fan / motor Type		Propeller fan / Fix Speed - AC motor							
Airflow per Fan	(m ³ /h)	18000	18000	18000	18000	18000	18000	18000	18000
Max Power input per Motor	(kW)	1.2	1.2	1.2	1.2	1.2	1.2	1.2	1.2
Max Amps per Motor	(A)	2.9	2.9	2.9	2.9	2.9	2.9	2.9	2.9
Motor RPM	(rpm)	900	900	900	900	900	900	900	900
System data (5)									
Nb of refrigerant circuit	#	2	2	2	2	2	2	2	2
Minimum cooling load % (4) (7)	%	15	15	15	15	15	15	15	15
R134a/R513A refrigerant charge Circuit 1 / Circuit 2 (8)	(kg)	108/43	104/53	112/54	102/96	112/54	103/108	107/110	107/110
Oil charge Circuit 1 / Circuit 2	(l)	16/8	16/8	16/8	16/16	16/8	16/16	16/16	16/16
POE Oil type		OIL0048E or OIL0023E							

- (1) Indicative performance at Evaporator water temperature: 12°C / 7°C- Condenser air temperature 35°C- for detailed performances consult Order Write Up.
- (2) Under 400V/3/50Hz.
- (3) Rated Condition without Pump Package.
- (4) Percent minimum load may be adjusted around 15%-20% according to operating conditions by local sales office.
- (5) Electrical & system data are indicative and subject to change without notice. Please refer to unit nameplate data.
- (6) Not applicable for Glycol application- see tables with Minimum Flow with Glycol.
- (7) Max speed - range is 60% to 100% of max speed.
- (8) Refrigerant charge may vary according to option- for instance +20% for process (digit 19 = p). For real value refer to unit nameplate.
- (9) Data containing information on two circuits shown as follows: ckt1/ckt2.

General Data

Table 17b – General Data RTAF 210-340 High Efficiency - AC Extra Low Noise - R1234 ze

		RTAF	RTAF	RTAF	RTAF	RTAF	RTAF
		210	230	265	285	305	340
		HE AC XLN	HE AC XLN	HE AC XLN	HE AC XLN	HE AC XLN	HE AC XLN
Net Cooling Capacity (1)	(kW)	726	820	892	1006	1094	1201
Unit electrical data (2) (3) (5)							
Maximum Power input in cooling	(kW)	346	403	403	479	533	538
Unit rated amps (Max compr+Fan+Control)	(A)	580	668	668	802	884	890
Unit start up amps (Starting Amps of the largest compr)	(A)	730	818	818	952	1034	1040
Displacement Power factor (DPF)		0.86	0.87	0.87	0.87	0.87	0.87
Max Power cable cross section	mm ²	4*185	4*185	4*185	4*185	4*185	4*185
Disconnect switch size	(A)	1250	1250	1250	1250	1250	1250
Compressor							
Quantity	#	3	3	3	4	4	4
Type		Screw	Screw	Screw	Screw	Screw	Screw
Model		65-78/65	78-78/78	78-78/78	65-78/65-78	78-78/78-78	78-78/78-78
Max Compr Power input Circuit1 / Circuit2	(kW)	98-125/ 98	125-125/ 125	125-125/ 125	98-125/ 98-125	125-125/ 125-125	125-125/ 125-125
Max Amps Circuit1 / Circuit 2 (3) (5)	(A)	163-204/ 163	204-204/ 204	204-204/ 204	163-204/ 163-204	204-204/ 204-204	204-204/ 204-204
Start up Amps Circuit1 / Circuit 2 (3)(5)	(A)	291-354/ 354	354-354/ 354	354-354/ 354	291-354/ 291-354	354-354/ 354-354	354-354/ 354-354
Motor RPM	(rpm)	3000	3000	3000	3000	3000	3000
Oil sump heater Circuit1 / Circuit 2	(W)	700	700	700	850	850	850
Evaporator							
Quantity	#	1	1	1	1	1	1
Type		Flooded shell and tube heat exchanger					
Evaporator model		300E	300D	300D	500E	500D	500D
Evaporator Water Content volume	(l)	86	97	97	130	146	146
Antifreeze Heater	(W)	2240	2240	2240	2440	2440	2440
Two pass evaporator							
Evap. Water Flow rate - Minimum	(l/s)	15.7	17.7	17.7	22.2	25.0	25.0
Evap. Water Flow rate - Maximum (6)	(l/s)	58.5	65.8	65.8	82.6	92.8	92.8
Nominal water connection size (Grooved coupling)	(in) - (mm)	6" - 150	6" - 150	6" - 150	8" - 200	8" - 200	8" - 201
Two pass evaporator with turbulator							
Evap. Water Flow rate - Minimum	(l/s)	13.2	14.8	14.8	18.5	20.8	20.8
Evap. Water Flow rate - Maximum (6)	(l/s)	52.5	59.1	59.1	74.2	83.4	83.4
Nominal water connection size (Grooved coupling)	(in) - (mm)	6" - 150	6" - 150	6" - 150	8" - 200	8" - 200	8" - 201
Hydraulic Module Components							
Standard head pressure pump option (Twin pump)							
Available Head Pressure (1)	(kPa)	N/A	N/A	N/A	N/A	N/A	N/A
Max. Motor Power Input	(kW)	11.0	11.0	15.0	15.0	15.0	22.0
Max. Rated Amps	(A)	20.8	20.8	29.0	29.0	29.0	39.7
High head pressure pump option (Twin pump)							
Available Head Pressure (1)	(kPa)	N/A	N/A	N/A	N/A	N/A	N/A
Max. Motor Power Input	(kW)	18.5	18.5	22.0	22.0	22.0	0.0
Max. Amps	(A)	34.5	34.5	39.7	39.7	39.7	0.0
Expansion Tank Volume	(l)	N/A	N/A	N/A	N/A	N/A	N/A
Max User water loop Volume for factory mounted expansion tank (1)	(l)	N/A	N/A	N/A	N/A	N/A	N/A
Max. Water-side Operating Pressure without pump package	(kPa)	N/A	N/A	N/A	N/A	N/A	N/A
Max. Water-side Operating Pressure with pump package	(kPa)	N/A	N/A	N/A	N/A	N/A	N/A
Antifreeze Heater with pump package	(W)	3300	3300	3400	3600	3600	3600
Condenser							
Type		Full aluminum Micro channel heat exchanger					
Quantity	#	12/4	12/6	12/6	12/10	12/10	12/12
Face area per coil	(m ²)	2.4	2.4	2.4	2.4	2.4	2.4
Condenser Fan							
Quantity	#	12/4	12/6	12/6	12/10	12/10	12/12
Diameter	(mm)	800	800	800	800	800	800
Standard / High ambient fan option							
Fan / motor Type		Propeller fan / Fixed speed - AC motor					
Airflow per Fan	(m ³ /h)	18000	18000	18000	18000	18000	18000
Max Power Input per Motor	(kW)	1.2	1.2	1.2	1.2	1.2	1.2
Max Amps per Motor	(A)	2.9	2.9	2.9	2.9	2.9	2.9
Motor RPM	(rpm)	900	900	900	900	900	900

General Data

Table 17b – General Data RTAF 210-340 High Efficiency - AC Extra Low Noise - R1234 ze (continued)

		RTAF 210	RTAF 230	RTAF 265	RTAF 285	RTAF 305	RTAF 340
		HE AC XLN	HE AC XLN	HE AC XLN	HE AC XLN	HE AC XLN	HE AC XLN
Low ambient fan option							
Fan / motor Type		Propeller fan / Variable speed - EC motor					
Airflow per Fan	(m ³ /h)	18000	18000	18000	18000	18000	18000
Max Power Input per Motor	(kW)	1.2	1.2	1.2	1.2	1.2	1.2
Max Amps per Motor	(A)	2.9	2.9	2.9	2.9	2.9	2.9
Motor RPM	(rpm)	900	900	900	900	900	900
System data (5)							
Nb of refrigerant circuit	#	2	2	2	2	2	2
Minimum cooling load % (4) (7)	%	15	15	15	15	15	15
Refrigerant charge Circuit 1 / Circuit 2	(kg)	98/40	104/49	104/49	100/92	102/96	102/102
Oil charge Circuit 1 / Circuit 2	(l)	13/7	13/7	13/7	13/13	13/13	13/13
POE Oil type (10)		OIL00317 or OIL00315					

(1) Indicative performance at Evaporator water temperature: 12°C / 7°C - Condenser air temperature 35°C - for detailed performances consult Order Write Up.

(2) Under 400V/3/50Hz.

(3) Rated Condition without Pump Package.

(4) Percent minimum load may be adjusted around 15%-20% according to operating conditions by local sales office.

(5) Electrical & system data are indicative and subject to change without notice. Please refer to unit nameplate data.

(6) Not applicable for Glycol application - see tables with Minimum Flow with Glycol.

(7) Max speed - range is 60% to 100% of max speed.

(8) Refrigerant charge may vary according to option - for instance +20% for process (digit 19 = p). For real value refer to unit nameplate.

(9) Data containing information on two circuits shown as follows: ckt1/ckt2.

(10) OIL0066E or OIL0067E may have been used on early orders and there is no restriction to continue to use them but preferable oil is OIL00315 or OIL00317.

General Data

Table 18a – General Data RTAF 250-450 Extra Efficiency - Standard and Low Noise - R134a - R513A

		RTAF 250	RTAF 280	RTAF 310	RTAF 350	RTAF 355	RTAF 380	RTAF 410	RTAF 415	RTAF 450
		XE SN LN	XE SN LN	XE SN LN	XE SN LN	XE SN LN	XE SN LN	XE SN LN	XE SN LN	XE SN LN
Cooling Capacity (1)	(kW)	876	990	1107	1237	1218	1359	1463	1479	1606
Unit electrical data (2) (3) (5)										
Maximum Power input in cooling	(kW)	374	424	485	530	544	580	625	625	704
Unit rated amps (Max compr +Fan+Control)	(A)	620	700	802	874	900	958	1036	1037	1169
Unit start up amps (Starting Amps of the largest compr+RLA of 2nd compr+RLA of all fans+ control)	(A)	773	853	916	1027	982	1111	1150	1151	1251
Displacement Power Factor (DPF)		0.87	0.88	0.88	0.88	0.87	0.88	0.87	0.87	0.87
Max power cable cross section	(mm ²)	4x185	4x185	4x185	4x185	4x185	4x185	4x185	4x185	6x185
Disconnect switch size	(A)	1250	1250	1250	1250	1250	1250	1250	1250	1600
Compressor										
Quantity	#	3	3	3	4	3	4	4	4	4
Type		Screw	Screw	Screw	Screw	Screw	Screw	Screw	Screw	Screw
Model (9)		85-85/ 70	85-100/ 85	100-100/ 100	85-85/ 85-85	115-115/ 115	85-100/ 85-100	100-100/ 100-100	100-100/ 100-101	115-115/ 115-115
Max Compr Power input Circuit 1/ Circuit 2	kW	121-121/ 99	121-144/ 121	144-144/ 144	121-121/ 121-121	164-164/ 164	121-144/ 121-144	144-144/ 144-144	144-144/ 144-144	164-164/ 164-164
Max Amps Circuit 1 / Circuit 2 (3) (5)	(A)	201-201/ 166	201-240/ 201	240-240/ 240	201-201/ 201-201	273-273/ 273	201-240/ 201-240	240-240/ 240-240	240-240/ 240-240	273-273/ 273-273
Start up Amps Circuit 1 / Circuit 2 (3) (5)	(A)	354-354/ 291	354-354/ 354	354-354/ 354	354-354/ 354-354	354-354/ 354	354-354/ 354-354	354-354/ 354-354	354-354/ 354-354	354-354/ 354-354
Motor RPM	(rpm)	3000	3000	3000	3000	3000	3000	3000	3000	3000
Oil sump heater Circuit 1 / Circuit 2	(W)	300/150	300/150	300/150	300/300	300/300	300/300	300/300	300/300	300/300
Evaporator										
Quantity	#	1	1	1	1	1	1	1	1	1
Type		Flooded shell and tube heat exchanger								
Evaporator model		300D	300B	300A	500D	300A	500C	500B	500B	500B
Evaporator Water Content volume	(l)	97	108	120	146	120	159	170	170	170
Antifreeze Heater	(W)	2240	2240	2240	2440	2440	2440	2440	2440	2440
Two pass evaporator										
Evap. Water Flow rate - Minimum	(l/s)	17.7	20.1	22.8	25.0	22.8	27.8	30.3	30.3	30.3
Evap. Water Flow rate - Maximum (6)	(l/s)	65.8	74.5	84.8	92.8	84.8	103.0	112.5	112.5	112.5
Nominal water connection size (Grooved coupling)	(in) - (DN)	6" - 150	6" - 150	6" - 150	8" - 200	6" - 150	8" - 200	8" - 200	8" - 200	8" - 200
Two pass evaporator with turbulator										
Evap. Water Flow rate - Minimum (6)	(l/s)	14.8	16.7	19.0	20.8	19.0	23.1	25.3	25.3	25.3
Evap. Water Flow rate - Maximum	(l/s)	59.1	66.9	76.1	83.4	76.1	92.5	101.1	101.1	101.1
Nominal water connection size (Grooved coupling)	(in) - (mm)	6" - 150	6" - 150	6" - 150	8" - 200	6" - 150	8" - 200	8" - 200	8" - 200	8" - 200
Hydraulic Module Components										
Standard head pressure pump option (Twin pump)										
Available Head Pressure (1)	(kPa)	160	106	115	139	82	127	116	116	77
Max Motor Power input	(kW)	15	15	15	22	15	22	22	22	22
Max Amps	(A)	28	28	28	39.7	28	39.7	39.7	39.7	39.7
High head pressure pump option (Twin Pump)										
Available Head Pressure (1)	(kPa)	216	220	174	NA	175	NA	NA	NA	NA
Max Motor Power input	(kW)	18.5	22	22	NA	22	NA	NA	NA	NA
Max Amps	(A)	34.5	39.7	39.7	NA	39.7	NA	NA	NA	NA
Expansion Tank Volume	(l)	80	160	160	160	160	160	160	160	160
Max User water loop Volume for factory mounted expansion tank (1)	(l)	40000	8000	8000	8000	8000	8000	8000	8000	8000
Max. Water-side Operating Pressure without pump package	(kPa)	1000	1000	1000	1000	1000	1000	1000	1000	1000
Max. Water-side Operating Pressure with pump package	(kPa)	450	450	450	450	450	450	450	450	450
Antifreeze Heater with pump package	(W)	3300	3400	3400	3600	3400	3600	3600	3600	3600
Condenser										
Type		Full aluminum Micro channel heat exchanger								
Quantity	#	12/4	12/6	14/6	12/10	14/6	12/12	12/12	12/12	12/12
Face area per coil	(m ²)	2.4	2.4	2.4	2.4	2.4	2.4	2.4	2.4	2.4
Condenser Fan										
Quantity	#	12/4	12/6	14/6	12/10	14/6	12/12	12/12	12/12	12/12
Diameter	(mm)	800	800	800	800	800	800	800	800	800
Standard / High ambient fan option										
Fan / motor Type		Propeller fan / Variable Speed - EC motor								
Airflow per Fan	(m ³ /h)	20000	20000	20000	20000	20000	20000	20000	22500	20000
Max Power input per Motor	(kW)	1.3	1.3	1.3	1.3	1.3	1.3	1.3	1.9	1.3
Max Amps per Motor	(A)	2.3	2.3	2.3	2.3	2.3	2.3	2.3	3.0	2.3
Motor RPM	(rpm)	910	910	910	910	910	910	910	1020	910

General Data

Table 18a – General Data RTAF 250-450 Extra Efficiency - Standard and Low Noise - R134a - R513A (continued)

		RTAF 250	RTAF 280	RTAF 310	RTAF 350	RTAF 355	RTAF 380	RTAF 410	RTAF 415	RTAF 450
		XE SN LN	XE SN LN	XE SN LN	XE SN LN	XE SN LN	XE SN LN	XE SN LN	XE SN LN	XE SN LN
Low ambient fan option										
Fan / motor Type		Propeller fan / Variable Speed - EC motor								
Airflow per Fan	(m ³ /h)	20000	20000	20000	20000	20000	20000	20000	22500	20000
Max Power input per Motor	(kW)	1.3	1.3	1.3	1.3	1.3	1.3	1.3	1.9	1.3
Max Amps per Motor	(A)	2.3	2.3	2.3	2.3	2.3	2.3	2.3	3.0	2.3
Motor RPM	(rpm)	910	910	910	910	910	910	910	1020	910
System data (5)										
Nb of refrigerant circuit	#	2	2	2	2	2	2	2	2	2
Minimum cooling load % (4) (7)	%	15	15	15	15	15	15	15	15	15
R134a/R513A refrigerant charge Circuit 1 / Circuit 2 (8)	(kg)	108/43	104/53	112/54	102/96	112/54	103/108	107/110	125/122	107/110
Oil charge Circuit 1 / Circuit 2	(l)	16/8	16/8	16/8	16/16	16/8	16/16	16/16	16/16	16/16
POE Oil type		OIL0048E or OIL0023E								

- (1) Indicative performance at Evaporator water temperature: 12°C / 7°C - Condenser air temperature 35°C- for detailed performances consult Order Write Up.
- (2) Under 400V/3/50Hz.
- (3) Rated Condition without Pump Package.
- (4) Percent minimum load may be adjusted around 15%-20% according to operating conditions by local sales office.
- (5) Electrical & system data are indicative and subject to change without notice. Please refer to unit nameplate data.
- (6) Not applicable for Glycol application- see tables with Minimum Flow with Glycol.
- (7) Max speed - range is 60% to 100% of max speed.
- (8) Refrigerant charge may vary according to option - for instance +20% for process (digit 19=P). For real value refer to unit nameplate.
- (9) Data containing information on two circuits shown as follows: ckt1/ckt2.

General Data

Table 18b – General Data RTAF 210-340 Extra Efficiency- Standard and Low Noise - R1234 ze

		RTAF	RTAF	RTAF	RTAF	RTAF	RTAF
		210	230	265	285	305	340
		XE SN LN	XE SN LN	XE SN LN	XE SN LN	XE SN LN	XE SN LN
Net Cooling Capacity (1)	(kW)	730	824	895	1011	1101	1205
Unit electrical data (2) (3) (5)							
Maximum Power input in cooling	(kW)	346	403	403	479	533	536
Unit rated amps (Max compr+Fan+Control)	(A)	580	668	668	802	884	890
Unit start up amps (Starting Amps of the largest compr)	(A)	730	818	818	952	1034	1040
Displacement Power factor (DPF)		0.86	0.87	0.87	0.87	0.87	0.87
Max Power cable cross section	mm ²	4*185	4*185	4*185	4*185	4*185	4*185
Disconnect switch size	(A)	1250	1250	1250	1250	1250	1250
Compressor							
Quantity	#	3	3	3	4	4	4
Type		Screw	Screw	Screw	Screw	Screw	Screw
Model		65-78/65	78-78/78	78-78/78	65-78/65-78	78-78/78-78	78-78/78-78
Max Compr Power input Circuit1 / Circuit2	(kW)	98-125/ 98	125-125/ 125	125-125/ 125	98-125/ 98-125	125-125/ 125-125	125-125/ 125-125
Max Amps Circuit1 / Circuit 2 (3) (5)	(A)	163-204/ 163	204-204/ 204	204-204/ 204	163-204/ 163-204	204-204/ 204-204	204-204/ 204-204
Start up Amps Circuit1 / Circuit 2 (3)(5)	(A)	291-354/ 354	354-354/ 354	354-354/ 354	291-354/ 291-354	354-354/ 354-354	354-354/ 354-354
Motor RPM	(rpm)	3000	3000	3000	3000	3000	3000
Oil sump heater Circuit1 / Circuit 2	(W)	700	700	700	850	850	850
Evaporator							
Quantity	#	1	1	1	1	1	1
Type		Flooded shell and tube heat exchanger					
Evaporator model		300E	300D	300D	500E	500D	500D
Evaporator Water Content volume	(l)	86	97	97	130	146	146
Antifreeze Heater	(W)	2240	2240	2240	2440	2440	2440
Two pass evaporator							
Evap. Water Flow rate - Minimum	(l/s)	15.7	17.7	17.7	22.2	25.0	25.0
Evap. Water Flow rate - Maximum (6)	(l/s)	58.5	65.8	65.8	82.6	92.8	92.8
Nominal water connection size (Grooved coupling)	(in) - (mm)	6" - 150	6" - 150	6" - 150	8" - 200	8" - 200	8" - 201
Two pass evaporator with turbulator							
Evap. Water Flow rate - Minimum	(l/s)	13.2	14.8	14.8	18.5	20.8	20.8
Evap. Water Flow rate - Maximum (6)	(l/s)	52.5	59.1	59.1	74.2	83.4	83.4
Nominal water connection size (Grooved coupling)	(in) - (mm)	6" - 150	6" - 150	6" - 150	8" - 200	8" - 200	8" - 201
Hydraulic Module Components							
Standard head pressure pump option (Twin pump)							
Available Head Pressure (1)	(kPa)	N/A	N/A	N/A	N/A	N/A	N/A
Max. Motor Power Input	(kW)	11.0	11.0	15.0	15.0	15.0	22.0
Max. Rated Amps	(A)	20.8	20.8	29.0	29.0	29.0	39.7
High head pressure pump option (Twin pump)							
Available Head Pressure (1)	(kPa)	N/A	N/A	N/A	N/A	N/A	N/A
Max. Motor Power Input	(kW)	18.5	18.5	22.0	22.0	22.0	0.0
Max. Amps	(A)	34.5	34.5	39.7	39.7	39.7	0.0
Expansion Tank Volume	(l)	N/A	N/A	N/A	N/A	N/A	N/A
Max User water loop Volume for factory mounted expansion tank (1)	(l)	N/A	N/A	N/A	N/A	N/A	N/A
Max. Water-side Operating Pressure without pump package	(kPa)	N/A	N/A	N/A	N/A	N/A	N/A
Max. Water-side Operating Pressure with pump package	(kPa)	N/A	N/A	N/A	N/A	N/A	N/A
Antifreeze Heater with pump package	(W)	3300	3300	3400	3600	3600	3600
Condenser							
Type		Full aluminum Micro channel heat exchanger					
Quantity	#	12/4	12/6	12/6	12/10	12/10	12/12
Face area per coil	(m ²)	2.4	2.4	2.4	2.4	2.4	2.4
Condenser Fan							
Quantity	#	12/4	12/6	12/6	12/10	12/10	12/12
Diameter	(mm)	800	800	800	800	800	800
Standard / High ambient fan option							
Fan / motor Type		Propeller fan / Variable speed - EC motor					
Airflow per Fan	(m ³ /h)	20000	20000	20000	20000	20000	20000
Max Power Input per Motor	(kW)	1.3	1.3	1.3	1.3	1.3	1.3
Max Amps per Motor	(A)	2.3	2.3	2.3	2.3	2.3	2.3
Motor RPM	(rpm)	910	910	910	910	910	910

General Data

Table 18b – General Data RTAF 210-340 Extra Efficiency - Standard and Low Noise - R1234 ze (continued)

		RTAF 210	RTAF 230	RTAF 265	RTAF 285	RTAF 305	RTAF 340
		XE SN LN	XE SN LN	XE SN LN	XE SN LN	XE SN LN	XE SN LN
Low ambient fan option							
Fan / motor Type		Propeller fan / Variable speed - EC motor					
Airflow per Fan	(m ³ /h)	20000	20000	20000	20000	20000	20000
Max Power Input per Motor	(kW)	1.3	1.3	1.3	1.3	1.3	1.3
Max Amps per Motor	(A)	2.3	2.3	2.3	2.3	2.3	2.3
Motor RPM	(rpm)	910	910	910	910	910	910
System data (5)							
Nb of refrigerant circuit	#	2	2	2	2	2	2
Minimum cooling load % (4) (7)	%	15	15	15	15	15	15
Refrigerant charge Circuit 1 / Circuit 2	(kg)	98/40	104/49	104/49	100/92	102/96	102/102
Oil charge Circuit 1 / Circuit 2	(l)	13/7	13/7	13/13	13/13	13/13	13/13
POE Oil type (10)		OIL00317 or OIL00315					

(1) Indicative performance at Evaporator water temperature: 12°C / 7°C - Condenser air temperature 35°C - for detailed performances consult Order Write Up.

(2) Under 400V/3/50Hz.

(3) Rated Condition without Pump Package.

(4) Percent minimum load may be adjusted around 15%-20% according to operating conditions by local sales office.

(5) Electrical & system data are indicative and subject to change without notice. Please refer to unit nameplate data.

(6) Not applicable for Glycol application - see tables with Minimum Flow with Glycol.

(7) Max speed - range is 60% to 100% of max speed.

(8) Refrigerant charge may vary according to option - for instance +20% for process (digit 19 = p). For real value refer to unit nameplate.

(9) Data containing information on two circuits shown as follows: ckt1/ckt2.

(10) OIL0066E or OIL0067E may have been used on early orders and there is no restriction to continue to use them but preferable oil is OIL00315 or OIL00317.

General Data

Table 19a – General Data RTAF 250-450 Extra Efficiency - Extra Low Noise - R134a - R513A

		RTAF 250 XE XLN	RTAF 280 XE XLN	RTAF 310 XE XLN	RTAF 350 XE XLN	RTAF 355 XE XLN	RTAF 380 XE XLN	RTAF 410 XE XLN	RTAF 450 XE XLN
Cooling Capacity (1)	(kW)	875	990	1107	1237	1217	1358	1463	1606
Unit electrical data (2) (3) (5)									
Maximum Power input in cooling	(kW)	374	424	485	530	544	580	625	704
Unit rated amps (Max compr +Fan+Control)	(A)	620	700	802	874	900	958	1036	1169
Unit start up amps (Starting Amps of the largest compr+RLA of 2nd compr+RLA of all fans+ control)	(A)	773	853	916	1027	982	1111	1150	1251
Displacement Power Factor (DPF)		0.87	0.88	0.88	0.88	0.87	0.88	0.87	0.87
Max power cable cross section	(mm ²)	4x185	4x185	4x185	4x185	4x185	4x185	4x185	6x185
Disconnect switch size	(A)	1250	1250	1250	1250	1250	1250	1250	1600
Compressor									
Quantity	#	3	3	3	4	3	4	4	4
Type		Screw	Screw	Screw	Screw	Screw	Screw	Screw	Screw
Model (9)		85-85/70	85-100/85	100-100/100	85-85/ 85-85	115-115/ 115	85-100/ 85-100	100-100/ 100-100	115-115/ 115-115
Max Compr Power input Circuit 1/ Circuit 2	(kW)	121-121/99	121-144/121	144-144/144	121-121/ 121-121	164-164/ 164	121-144/ 121-144	144-144/ 144-144	164-164/ 164-164
Max Amps Circuit 1 / Circuit 2 (3) (5)	(A)	201-201/166	201-240/201	240-240/240	201-201/ 201-201	273-273/ 273	201-240/ 201-240	240-240/ 240-240	273-273/ 273-273
Start up Amps Circuit 1 / Circuit 2 (3) (5)	(A)	354-354/291	354-354/354	354-354/354	354-354/ 354-354	354-354/ 354	354-354/ 354-354	354-354/ 354-354	354-354/ 354-354
Motor RPM	(rpm)	3000	3000	3000	3000	3000	3000	3000	3000
Oil sump heater Circuit 1 / Circuit 2	(W)	300/150	300/150	300/150	300/300	300/300	300/300	300/300	300/300
Evaporator									
Quantity	#	1	1	1	1	1	1	1	1
Type		Flooded shell and tube heat exchanger							
Evaporator model		300D	300B	300A	500D	300A	500C	500B	500B
Evaporator Water Content volume	(l)	97	108	120	146	120	159	170	170
Antifreeze Heater	(W)	2240	2240	2240	2440	2440	2440	2440	2440
Two pass evaporator									
Evap. Water Flow rate - Minimum	(l/s)	17.7	20.1	22.8	25.0	22.8	27.8	30.3	30.3
Evap. Water Flow rate - Maximum (6)	(l/s)	65.8	74.5	84.8	92.8	84.8	103.0	112.5	112.5
Nominal water connection size (Grooved coupling)	(in) - (DN)	6" - 150	6" - 150	6" - 150	8" - 200	6" - 150	8" - 200	8" - 200	8" - 200
Two pass evaporator with turbulator									
Evap. Water Flow rate - Minimum (6)	(l/s)	14.8	16.7	19.0	20.8	19.0	23.1	25.3	25.3
Evap. Water Flow rate - Maximum	(l/s)	59.1	66.9	76.1	83.4	76.1	92.5	101.1	101.1
Nominal water connection size (Grooved coupling)	(in) - (mm)	6" - 150	6" - 150	6" - 150	8" - 200	6" - 150	8" - 200	8" - 200	8" - 200
Hydraulic Module Components									
Standard head pressure pump option (Twin pump)									
Available Head Pressure (1)	(kPa)	160	106	115	139	82	127	116	77
Max Motor Power input	(kW)	15	15	15	22	15	22	22	22
Max Amps	(A)	28	28	28	39.7	28	39.7	39.7	39.7
High head pressure pump option (Twin Pump)									
Available Head Pressure (1)	(kPa)	216	220	174	NA	175	NA	NA	NA
Max Motor Power input	(kW)	18.5	22	22	NA	22	NA	NA	NA
Max Amps	(A)	34.5	39.7	39.7	NA	39.7	NA	NA	NA
Expansion Tank Volume	(l)	80	160	160	NA	160	NA	NA	160
Max User water loop Volume for factory mounted expansion tank (1)	(l)	4000	8000	8000	8000	8000	8000	8000	8000
Max. Water-side Operating Pressure without pump package	(kPa)	1000	1000	1000	1000	1000	1000	1000	1000
Max. Water-side Operating Pressure with pump package	(kPa)	450	450	450	450	450	450	450	450
Antifreeze Heater with pump package	(W)	3300	3400	3400	3600	3400	3600	3600	3600
Condenser									
Type		Full aluminum Micro channel heat exchanger							
Quantity	#	12/4	12/6	14/6	12/10	14/6	12/12	12/12	12/12
Face area per coil	(m ²)	2.4	2.4	2.4	2.4	2.4	2.4	2.4	2.4
Condenser Fan									
Quantity	#	12/4	12/6	14/6	12/10	14/6	12/12	12/12	12/12
Diameter	(mm)	800	800	800	800	800	800	800	800
Standard / High ambient fan option									
Fan / motor Type		Propeller fan / Fixed Speed - EC motor							
Airflow per Fan	(m ³ /h)	20500	20500	20500	20500	20500	20500	20500	20500
Max Power input per Motor	(kW)	1.1	1.1	1.1	1.1	1.1	1.1	1.1	1.1
Max Amps per Motor	(A)	1.9	1.9	1.9	1.9	1.9	1.9	1.9	1.9
Motor RPM	(rpm)	885	885	885	885	885	885	885	885

General Data

Table 19a – General Data RTAF 250-450 Extra Efficiency - Extra Low Noise - R134a - R513A (continued)

		RTAF 250	RTAF 280	RTAF 310	RTAF 350	RTAF 355	RTAF 380	RTAF 410	RTAF 450
		XE XLN	XE XLN	XE XLN	XE XLN	XE XLN	XE XLN	XE XLN	XE XLN
Low ambient fan option									
Fan / motor Type		Propeller fan / Fixed Speed - EC motor							
Airflow per Fan	(m ³ /h)	20000	20000	20000	20000	20000	20000	20000	20000
Max Power input per Motor	(kW)	1.1	1.1	1.1	1.1	1.1	1.1	1.1	1.1
Max Amps per Motor	(A)	1.8	1.8	1.8	1.8	1.8	1.8	1.8	1.8
Motor RPM	(rpm)	860	860	860	860	860	860	860	860
System data (5)									
Nb of refrigerant circuit	#	2	2	2	2	2	2	2	2
Minimum cooling load % (4) (7)	%	15	15	15	15	15	15	15	15
R134a/R513A refrigerant charge Circuit 1 / Circuit 2 (8)	(kg)	108/43	104/53	112/54	102/96	112/54	103/108	107/110	107/110
Oil charge Circuit 1 / Circuit 2	(l)	16/8	16/8	16/8	16/16	16/8	16/16	16/16	16/16
POE Oil type		OIL0048E or OIL0023E							

- (1) Indicative performance at Evaporator water temperature: 12°C / 7°C - Condenser air temperature 35°C- for detailed performances consult Order Write Up.
- (2) Under 400V/3/50Hz.
- (3) Rated Condition without Pump Package.
- (4) Percent minimum load may be adjusted around 15%-20% according to operating conditions by local sales office.
- (5) Electrical & system data are indicative and subject to change without notice. Please refer to unit nameplate data.
- (6) Not applicable for Glycol application- see tables with Minimum Flow with Glycol.
- (7) Max speed - range is 60% to 100% of max speed.
- (8) Refrigerant charge may vary according to option - for instance +20% for process (digit 19=P). For real value refer to unit nameplate.
- (9) Data containing information on two circuits shown as follows: ckt1/ckt2.

General Data

Table 19b – General Data RTAF 210-340 Extra Efficiency- Extra Low Noise - R1234 ze

		RTAF 210 XE XLN	RTAF 230 XE XLN	RTAF 265 XE XLN	RTAF 285 XE XLN	RTAF 305 XE XLN	RTAF 340 XE XLN
Net Cooling Capacity (1)	(kW)	730	824	895	1011	1101	1205
Unit electrical data (2) (3) (5)							
Maximum Power input in cooling	(kW)	346	403	403	479	533	536
Unit rated amps (Max compr+Fan+Control)	(A)	580	668	668	802	884	890
Unit start up amps (Starting Amps of the largest compr)	(A)	730	818	818	952	1034	1040
Displacement Power factor (DPF)		0.86	0.87	0.87	0.87	0.87	0.87
Max Power cable cross section	mm ²	4*185	4*185	4*185	4*185	4*185	4*185
Disconnect switch size	(A)	1250	1250	1250	1250	1250	1250
Compressor							
Quantity	#	3	3	3	4	4	4
Type		Screw	Screw	Screw	Screw	Screw	Screw
Model		65-78/65	78-78/78	78-78/78	65-78/65-78	78-78/78-78	78-78/78-78
Max Compr Power input Circuit1 / Circuit2	(kW)	98-125/ 98	125-125/ 125	125-125/ 125	98-125/ 98-125	125-125/ 125-125	125-125/ 125-125
Max Amps Circuit1 / Circuit 2 (3) (5)	(A)	163-204/ 163	204-204/ 204	204-204/ 204	163-204/ 163-204	204-204/ 204-204	204-204/ 204-204
Start up Amps Circuit1 / Circuit 2 (3)(5)	(A)	291-354/ 354	354-354/ 354	354-354/ 354	291-354/ 291-354	354-354/ 354-354	354-354/ 354-354
Motor RPM	(rpm)	3000	3000	3000	3000	3000	3000
Oil sump heater Circuit1 / Circuit 2	(W)	700	700	700	850	850	850
Evaporator							
Quantity	#	1	1	1	1	1	1
Type		Flooded shell and tube heat exchanger					
Evaporator model		300E	300D	300D	500E	500D	500D
Evaporator Water Content volume	(l)	86	97	97	130	146	146
Antifreeze Heater	(W)	2240	2240	2240	2440	2440	2440
Two pass evaporator							
Evap. Water Flow rate - Minimum	(l/s)	15.7	17.7	17.7	22.2	25.0	25.0
Evap. Water Flow rate - Maximum (6)	(l/s)	58.5	65.8	65.8	82.6	92.8	92.8
Nominal water connection size (Grooved coupling)	(in) - (mm)	6" - 150	6" - 150	6" - 150	8" - 200	8" - 200	8" - 201
Two pass evaporator with turbulator							
Evap. Water Flow rate - Minimum	(l/s)	13.2	14.8	14.8	18.5	20.8	20.8
Evap. Water Flow rate - Maximum (6)	(l/s)	52.5	59.1	59.1	74.2	83.4	83.4
Nominal water connection size (Grooved coupling)	(in) - (mm)	6" - 150	6" - 150	6" - 150	8" - 200	8" - 200	8" - 201
Hydraulic Module Components							
Standard head pressure pump option (Twin pump)							
Available Head Pressure (1)	(kPa)	N/A	N/A	N/A	N/A	N/A	N/A
Max. Motor Power Input	(kW)	11.0	11.0	15.0	15.0	15.0	22.0
Max. Rated Amps	(A)	20.8	20.8	29.0	29.0	29.0	39.7
High head pressure pump option (Twin pump)							
Available Head Pressure (1)	(kPa)	N/A	N/A	N/A	N/A	N/A	N/A
Max. Motor Power Input	(kW)	18.5	18.5	22.0	22.0	22.0	0.0
Max. Amps	(A)	34.5	34.5	39.7	39.7	39.7	0.0
Expansion Tank Volume	(l)	N/A	N/A	N/A	N/A	N/A	N/A
Max User water loop Volume for factory mounted expansion tank (1)	(l)	N/A	N/A	N/A	N/A	N/A	N/A
Max. Water-side Operating Pressure without pump package	(kPa)	N/A	N/A	N/A	N/A	N/A	N/A
Max. Water-side Operating Pressure with pump package	(kPa)	N/A	N/A	N/A	N/A	N/A	N/A
Antifreeze Heater with pump package	(W)	3300	3300	3400	3600	3600	3600
Condenser							
Type		Full aluminum Micro channel heat exchanger					
Quantity	#	12/4	12/6	12/6	12/10	12/10	12/12
Face area per coil	(m ²)	2.4	2.4	2.4	2.4	2.4	2.4
Condenser Fan							
Quantity	#	12/4	12/6	12/6	12/10	12/10	12/12
Diameter	(mm)	800	800	800	800	800	800
Standard / High ambient fan option							
Fan / motor Type		Propeller fan / Fixed speed - EC motor					
Airflow per Fan	(m ³ /h)	20000	20000	20000	20000	20000	20000
Max Power Input per Motor	(kW)	1.1	1.1	1.1	1.1	1.1	1.1
Max Amps per Motor	(A)	1.8	1.8	1.8	1.8	1.8	1.8
Motor RPM	(rpm)	860	860	860	860	860	860

General Data

Table 19b – General Data RTAF 210-340 Extra Efficiency - Extra Low Noise - R1234 ze (continued)

		RTAF 210 XE XLN	RTAF 230 XE XLN	RTAF 265 XE XLN	RTAF 285 XE XLN	RTAF 305 XE XLN	RTAF 340 XE XLN
Low ambient fan option							
Fan / motor Type		Propeller fan / Variable speed - EC motor					
Airflow per Fan	(m ³ /h)	20000	20000	20000	20000	20000	20000
Max Power Input per Motor	(kW)	1.1	1.1	1.1	1.1	1.1	1.1
Max Amps per Motor	(A)	1.8	1.8	1.8	1.8	1.8	1.8
Motor RPM	(rpm)	860	860	860	860	860	860
System data (5)							
Nb of refrigerant circuit	#	2	2	2	2	2	2
Minimum cooling load % (4) (7)	%	15	15	15	15	15	15
Refrigerant charge Circuit 1 / Circuit 2	(kg)	98/40	104/49	104/49	100/92	102/96	102/102
Oil charge Circuit 1 / Circuit 2	(l)	13/7	13/7	13/7	13/13	13/13	13/13
POE Oil type (10)		OIL00317 or OIL00315					

(1) Indicative performance at Evaporator water temperature: 12°C / 7°C - Condenser air temperature 35°C - for detailed performances consult Order Write Up.

(2) Under 400V/3/50Hz.

(3) Rated Condition without Pump Package.

(4) Percent minimum load may be adjusted around 15%-20% according to operating conditions by local sales office.

(5) Electrical & system data are indicative and subject to change without notice. Please refer to unit nameplate data.

(6) Not applicable for Glycol application - see tables with Minimum Flow with Glycol.

(7) Max speed - range is 60% to 100% of max speed.

(8) Refrigerant charge may vary according to option - for instance +20% for process (digit 19 = p). For real value refer to unit nameplate.

(9) Data containing information on two circuits shown as follows: ckt1/ckt2.

(10) OIL0066E or OIL0067E may have been used on early orders and there is no restriction to continue to use them but preferable oil is OIL00315 or OIL00317.

General Data

Table 20a – General Data RTAF 250-410 High Seasonal Efficiency Short - Standard and Low Noise - R134a - R513A

		RTAF	RTAF	RTAF	RTAF	RTAF	RTAF
		250	280	310	350	380	410
		HSS SN LN	HSS SN LN	HSS SN LN	HSS SN LN	HSS SN LN	HSS SN LN
Cooling Capacity (1)	(kW)	862	968	1066	1195	1312	1432
Unit electrical data (2) (3) (5)							
Maximum Power input in cooling	(kW)	375	425	471	527	577	627
Unit rated amps (Max compr +Fan+Control)	(A)	588	668	739	836	920	997
Unit start up amps (Starting Amps of the largest compr+RLA of 2nd compr+RLA of all fans+ control)	(A)	741	782	853	989	1034	1111
Unit Power factor		0.92	0.92	0.92	0.91	0.91	0.91
Max power cable cross section	(mm ²)	4*300	4*300	4*300	4*300	4*300	4*300
Disconnect switch size	(A)	1250	1250	1250	1250	1250	1250
Compressor							
Quantity	#	3	3	3	4	4	4
Type		Screw	Screw	Screw	Screw	Screw	Screw
Model (9)		85-85/70	85-100/85	100-100/100	85-85/85-85	85-100/85-100	100-100/100-100
Max Compr Power input Circuit 1/Circuit 2	kW	124-121/101	124-144/124	147-144/147	124-121/124-121	124-144/121-144	147-144/147-144
Max Amps Circuit 1 / Circuit 2 (3) (4)	(A)	188-201/153	188-240/188	224-240/224	188-201/188-201	188-240/188-240	238-240/238-240
Start up Amps Circuit 1 / Circuit 2 (3) (4)	(A)	188-354/153	188-354/188	224-354/224	188-354/188-354	188-354/188-354	224-354/224-354
Motor RPM	(rpm)	3000	3000	3000	3000	3000	3000
Oil sump heater Circuit 1 / Circuit 2	(W)	300/150	300/150	300/150	300/300	300/300	300/300
Evaporator							
Quantity	#	1	1	1	1	1	1
Type		Flooded shell and tube heat exchanger					
Evaporator model		300D	300B	300A	500D	500C	500B
Evaporator Water Content volume	(l)	97	108	120	146	159	170
Antifreeze Heater	(W)	2240	2240	2240	2440	2440	2440
One pass evaporator							
Evap. Water Flow rate - Minimum	(l/s)	17.7	20.1	22.8	25.0	27.8	30.3
Evap. Water Flow rate - Maximum (6)	(l/s)	65.8	74.5	84.8	92.8	103.0	112.5
Nominal water connection size (Grooved coupling)	(in) - (DN)	6" - 150	6" - 150	6" - 150	8" - 200	8" - 200	8" - 200
One pass with turbulator evaporator							
Evap. Water Flow rate - Minimum (6)	(l/s)	14.8	16.7	19.0	20.8	23.1	25.3
Evap. Water Flow rate - Maximum	(l/s)	59.1	66.9	76.1	83.4	92.5	101.1
Nominal water connection size (Grooved coupling)	(in) - (mm)	6" - 150	6" - 150	6" - 150	8" - 200	8" - 200	8" - 200
Hydraulic Module Components							
Standard head pressure pump option							
Available Head Pressure (1)	(kPa)	167	118	95	146	134	120
Max Motor Power input	(kW)	15	15	15	22	22	22
Max Amps	(A)	28	28	28	39.7	39.7	39.7
High head pressure pump option							
Available Head Pressure (1)	(kPa)	223	229	193	N/A	N/A	N/A
Max Motor Power input	(kW)	18.5	22	22	N/A	N/A	N/A
Max Amps	(A)	34.5	39.7	39.7	N/A	N/A	N/A
Expansion Tank Volume	(l)	80	160	160	160	160	160
Max User water loop Volume for factory mounted expansion tank (1)	(l)	4000	8000	8000	8000	8000	8000
Max. Water-side Operating Pressure without pump package	(kPa)	1000	1000	1000	1000	1000	1000
Max. Water-side Operating Pressure with pump package	(kPa)	450	450	450	450	450	450
Antifreeze Heater with pump package	(W)	3300	3400	3400	3600	3600	3600
Condenser							
Type		Full aluminum Micro channel heat exchanger					
Quantity	#	10/4	10/6	10/6	10/8	10/10	12/10
Face area per coil	(m ²)	2.4	2.4	2.4	2.4	2.4	2.4

General Data

Table 20a – General Data RTAF 250-410 High Seasonal Efficiency Short- Standard and Low Noise - R134a - R513A (continued)

		RTAF 250	RTAF 280	RTAF 310	RTAF 350	RTAF 380	RTAF 410
		HSS SN LN	HSS SN LN	HSS SN LN	HSS SN LN	HSS SN LN	HSS SN LN
Condenser Fan							
Quantity	#	10/4	10/6	10/6	10/8	10/10	12/10
Diameter	(mm)	800	800	800	800	800	800
Standard / High ambient fan option							
Fan / motor Type		Propeller fan / Variable speed - EC motor					
Airflow per Fan	(m ³ /h)	20000	20000	20000	20000	20000	21500
Max Power input per Motor	(kW)	1.3	1.3	1.3	1.3	1.3	1.4
Max Amps per Motor	(A)	2.3	2.3	2.3	2.3	2.3	2.5
Motor RPM	(rpm)	910	910	910	910	910	984
Low ambient fan option							
Fan / motor Type		Propeller fan / Variable speed - EC motor					
Airflow per Fan	(m ³ /h)	20000	20000	20000	20000	20000	21500
Max Power input per Motor	(kW)	1.3	1.3	1.3	1.3	1.3	1.4
Max Amps per Motor	(A)	2.3	2.3	2.3	2.3	2.3	2.5
Motor RPM	(rpm)	910	910	910	910	910	984
System data (5)							
Nb of refrigerant circuit	#	2	2	2	2	2	2
Minimum cooling load % (4) (7)	%	10	10	10	10	10	10
R134a/R513A refrigerant charge Circuit 1 / Circuit 2 (8)	(kg)	108/47	111/55	113/56	110/103	114/113	125/118
Oil charge Circuit 1 / Circuit 2	(l)	16/8	16/8	16/8	16/16	16/16	16/16
POE Oil type		OIL00317 or OIL00311					

- (1) Indicative performance at Evaporator water temperature: 12°C / 7°C - Condenser air temperature 35°C - for detailed performances consult Order Write Up.
(2) Under 400V/3/50Hz.
(3) Rated Condition without Pump Package.
(4) Percent minimum load may be adjusted around 15%-20% according to operating conditions by local sales office.
(5) Electrical & system data are indicative and subject to change without notice. Please refer to unit nameplate data.
(6) Not applicable for Glycol application - see tables with Minimum Flow with Glycol.
(7) Max speed - range is 60% to 100% of max speed.
(8) Refrigerant charge may vary according to option - for instance +20% for process (digit 19 = p). For real value refer to unit nameplate.
(9) Data containing information on two circuits shown as follows: ckt1/ckt2.

General Data

Table 20b – General Data RTAF 210-405 High Seasonal Efficiency Short- Standard and Low Noise - R1234 ze

		RTAF 210	RTAF 230	RTAF 265	RTAF 275	RTAF 285	RTAF 300	RTAF 305	RTAF 340	RTAF 385	RTAF 405
		HSS SN LN	HSS SN LN	HSS SN LN	HSS SN LN	HSS SN LN	HSS SN LN	HSS SN LN	HSS SN LN	HSS SN LN	HSS SN LN
Net Cooling Capacity (1)	(kW)	727	809	887	999	998	1105	1085	1188	1310	1426
Unit electrical data (2) (3) (5)											
Maximum Power input in cooling	(kW)	379	421	425	468	511	515	554	558	605	652
Unit rated amps (Max compr+Fan+Control)	(A)	591	656	662	727	807	799	872	878	949	1021
Unit start up amps (Starting Amps of the largest compr)	(A)	741	806	812	877	957	949	1022	1028	1099	1171
Displacement Power factor (DPF)		0.93	0.93	0.93	0.93	0.92	0.93	0.92	0.92	0.92	0.92
Max Power cable cross section	mm ²	4*185	4*185	4*185	4*185	4*185	4*185	4*185	4*185	4*185	6*185
Disconnect switch size	(A)	1250	1250	1250	1250	1250	1250	1250	1250	1250	1600
Compressor											
Quantity	#	3	3	3	3	4	3	4	4	4	4
Type		Screw	Screw	Screw	Screw	Screw	Screw	Screw	Screw	Screw	Screw
Model (9)		65-78/ 65	78-78/ 78	78-78/ 78	78-78/ 78	65-78/ 65-78	78-78/ 78	78-78/ 78-78	78-78/ 78-78	78-78/ 78-78	78-78/ 78-78
Max Compr Power input Circuit1/ Circuit2	(kW)	112-125/ 112	134-125/ 134	134-125/ 134	155-125/ 155	112-125/ 112-125	179-125/ 179	134-125/ 134-125	134-125/ 134-125	155-125/ 155-125	179-125/ 179-125
Max Amps Circuit1 / Circuit 2 (3) (4)	(A)	171-204/ 171	203-204/ 203	203-204/ 203	236-204/ 236	203-204/ 203-204	271-204/ 271	203-204/ 203-204	203-204/ 203-204	236-204/ 236-204	271-204/ 271-204
Start up Amps Circuit1 / Circuit 2 (3)(4)	(A)	171-354/ 171	203-354/ 203	203-354/ 203	236-204/ 236	171-354/ 171-354	271-354/ 271	203-354/ 203-354	203-354/ 203-354	236-354/ 236-354	271-354/ 271-354
Motor RPM	(rpm)	3000	3000	3000	3000	3000	3000	3000	3000	3000	3000
Oil sump heater Circuit1 / Circuit 2	(W)	700	700	700	700	850	700	850	850	850	850
Evaporator											
Quantity	#	1	1	1	1	1	1	1	1	1	1
Type		Flooded shell and tube heat exchanger									
Evaporator model		300E	300D	300D	300B	500E	300B	500D	500D	500C	500B
Evaporator Water Content volume	(l)	86	97	97	108	130	108	146	146	159	170
Antifreeze Heater	(W)	2240	2240	2240	2240	2440	2240	2440	2440	2440	2440
Two pass evaporator											
Evap. Water Flow rate - Maximum (6)	(l/s)	15.7	17.7	17.7	20.1	22.2	20.1	25.0	25.0	27.8	30.3
Evap. Water Flow rate - Maximum	(l/s)	58.5	65.8	65.8	74.5	82.6	74.5	92.8	92.8	103.0	112.5
Two pass evaporator with turbulator	(in) - (mm)	6" - 150	6" - 150	6" - 150	6" - 150	8" - 200	6" - 150	8" - 200	8" - 201	8" - 200	8" - 200
Two pass evaporator with turbulator											
Evap. Water Flow rate - Maximum (6)	(l/s)	13.2	14.8	14.8	16.7	18.5	16.7	20.8	20.8	23.1	25.3
Evap. Water Flow rate - Maximum	(l/s)	52.5	59.1	59.1	66.9	74.2	66.9	83.4	83.4	92.5	101.1
Nominal water connection size (Grooved coupling)	(in) - (mm)	6" - 150	6" - 150	6" - 150	6" - 150	8" - 200	6" - 150	8" - 200	8" - 201	8" - 200	8" - 200
Hydraulic Module Components											
Standard head pressure pump option (Twin pump)											
Max. Motor Power Input	(kPa)	N/A	N/A	N/A	N/A	N/A	N/A	N/A	N/A	N/A	N/A
Max. Motor Power	(kW)	11.0	11.0	15.0	15.0	15.0	15.0	15.0	22.0	22.0	22.0
High head pressure pump option (Twin pump)	(A)	20.8	20.8	29.0	29.0	29.0	29.0	29.0	39.7	39.7	39.7
High head pressure pump option (Twin pump)											
Max. Motor Power Input	(kPa)	N/A	N/A	N/A	N/A	N/A	N/A	N/A	N/A	N/A	N/A
Max. Amps	(kW)	18.5	18.5	22.0	22.0	22.0	22.0	22.0	0.0	0.0	0.0
Max. Rated Amps	(A)	34.5	34.5	39.7	39.7	39.7	39.7	39.7	0.0	0.0	0.0
Expansion Tank Volume	(l)	N/A	N/A	N/A	N/A	N/A	N/A	N/A	N/A	N/A	N/A
Max User water loop Volume for factory mounted expansion tank (1)	(l)	N/A	N/A	N/A	N/A	N/A	N/A	N/A	N/A	N/A	N/A
Max. Water-side Operating Pressure without pump package	(kPa)	N/A	N/A	N/A	N/A	N/A	N/A	N/A	N/A	N/A	N/A
Max. Water-side Operating Pressure with pump package	(kPa)	N/A	N/A	N/A	N/A	N/A	N/A	N/A	N/A	N/A	N/A
Antifreeze Heater with pump package	(W)	3300	3300	3400	3400	3600	3400	3600	3600	3600	3600
Condenser											
Type		Full aluminum Micro channel heat exchanger									
Quantity	#	10/4	10/4	10/6	10/6	10/8	10/6	10/8	10/10	12/10	12/10
Face area per coil	(m ²)	2.4	2.4	2.4	3.4	2.4	2.4	2.4	2.4	2.4	2.4
Condenser Fan											
Quantity	#	10/4	10/4	10/6	10/6	10/8	10/6	10/8	10/10	12/10	12/10
Diameter	(mm)	800	800	800	800	800	800	800	800	800	800
Standard / High ambient fan option											
Fan / motor Type		Propeller fan / Variable speed - EC motor									
Max Power Input per Motor	(m ³ /h)	20000	20000	20000	20000	20000	20000	20000	20000	20000	20000
Max Amps per Motor	(kW)	1.3	1.3	1.3	1.3	1.3	1.3	1.3	1.3	1.3	1.3
Motor RPM	(A)	2.3	2.3	2.3	2.3	2.3	2.3	2.3	2.3	2.3	2.3
Rated motor RPM	(rpm)	910	910	910	910	910	910	910	910	910	910

General Data

Table 20b – General Data RTAF 210-405 High Seasonal Efficiency Short- Standard and Low Noise - R1234 ze (continued)

		RTAF 210	RTAF 230	RTAF 265	RTAF 275	RTAF 285	RTAF 300	RTAF 305	RTAF 340	RTAF 385	RTAF 405
		HSS SN LN	HSS SN LN	HSS SN LN	HSS SN LN	HSS SN LN	HSS SN LN	HSS SN LN	HSS SN LN	HSS SN LN	HSS SN LN
Standard / High ambient fan option											
Fan / motor Type		Propeller fan / Variable speed - EC motor									
Max Power Input per Motor	(m ³ /h)	20000	20000	20000	20000	20000	20000	20000	20000	20000	20000
Max Amps per Motor	(kW)	1.3	1.3	1.3	1.3	1.3	1.3	1.3	1.3	1.3	1.3
Motor RPM	(A)	2.3	2.3	2.3	2.3	2.3	2.3	2.3	2.3	2.3	2.3
Maximum ambient operation High ambient (8)	(rpm)	55	55	55	55	55	55	55	55	55	55
System data (5)											
Minimum cooling load % (4) (7)	#	2	2	2	2	2	2	2	2	2	2
Minimum cooling load % (6)	%	15	15	15	15	15	15	15	15	15	15
Refrigerant charge Circuit 1 / Circuit 2	(kg)	90/40	93/44	93/49	96/51	90/88	96/51	94/91	94/96	108/100	107/104
Oil charge Circuit 1 / Circuit 2	(l)	13/7	13/7	13/7	13/7	13/13	13/7	13/13	13/13	13/13	13/13
POE Oil type (10)		OIL00317 or OIL00315									

(1) Indicative performance at Evaporator water temperature: 12°C / 7°C- Condenser air temperature 35°C- for detailed performances consult Order Write Up.

(2) Under 400V/3/50Hz.

(3) Rated Condition without Pump Package.

(4) Percent minimum load may be adjusted around 15%-20% according to operating conditions by local sales office.

(5) Electrical & system data are indicative and subject to change without notice. Please refer to unit nameplate data.

(6) Not applicable for Glycol application- see tables with Minimum Flow with Glycol.

(7) Max speed- range is 60% to 100% of max speed.

(8) Refrigerant charge may vary according to option- for instance +20% for process (digit 19 = p). For real value refer to unit nameplate.

(9) Data containing information on two circuits shown as follows: ckt1/ckt2.

(10) OIL0066E or OIL0067E may have been used on early orders and there is no restriction to continue to use them but preferable oil is OIL00315 or OIL00317.

General Data

Table 21a – General Data RTAF 250-410 High Seasonal Efficiency Short - Extra Low Noise - R134a - R513A

		RTAF 250 HSS XLN	RTAF 280 HSS XLN	RTAF 310 HSS XLN	RTAF 350 HSS XLN	RTAF 380 HSS XLN	RTAF 410 HSS XLN
Cooling Capacity (1)	(kW)	861	968	1065	1195	1311	1431
Unit electrical data (2) (3) (4)							
Maximum Power input in cooling	(kW)	375	425	471	527	577	627
Unit rated amps (Max compr +Fan+Control)	(A)	588	668	739	836	920	997
Unit start up amps (Starting Amps of the largest compr+RLA of 2nd compr+RLA of all fans+ control)	(A)	741	782	853	989	1034	1111
Unit Power factor		0.92	0.92	0.92	0.91	0.91	0.91
Max power cable cross section	(mm ²)	4*300	4*300	4*300	4*300	4*300	4*300
Disconnect switch size	(A)	1250	1250	1250	1250	1250	1250
Compressor							
Quantity	#	3	3	3	4	4	4
Type		Screw	Screw	Screw	Screw	Screw	Screw
Model (8)		85-85/70	85-100/85	100-100/100	85-85/85-85	85-100/85-100	100-100/100-100
Max Compr Power input Circuit 1/Circuit 2	kW	124-121/101	124-144/124	147-144/147	124-121/124-121	124-144/121-144	147-144/147-144
Max Amps Circuit 1 / Circuit 2 (3) (4)	(A)	188-201/153	188-240/188	224-240/224	188-201/188-201	188-240/188-240	224-240/224-240
Start up Amps Circuit 1 / Circuit 2 (3) (4)	(A)	188-354/153	188-354/188	224-354/224	188-354/188-354	188-354/188-354	224-354/224-354
Motor RPM	(rpm)	3000	3000	3000	3000	3000	3000
Oil sump heater Circuit 1 / Circuit 2	(W)	300/150	300/150	300/150	300/300	300/300	300/300
Evaporator							
Quantity	#	1	1	1	1	1	1
Type		Flooded shell and tube heat exchanger					
Evaporator model		300D	300B	300A	500D	500C	500B
Evaporator Water Content volume	(l)	97	108	120	146	159	170
Antifreeze Heater	(W)	2240	2240	2240	2440	2440	2440
One pass evaporator							
Evap. Water Flow rate - Minimum	(l/s)	17.7	20.1	22.8	25.0	27.8	30.3
Evap. Water Flow rate - Maximum (5)	(l/s)	65.8	74.5	84.8	92.8	103.0	112.5
Nominal water connection size (Grooved coupling)	(in) - (DN)	6" - 150	6" - 150	6" - 150	8" - 200	8" - 200	8" - 200
One pass with turbulator evaporator							
Evap. Water Flow rate - Minimum (5)	(l/s)	14.8	16.7	19.0	20.8	23.1	25.3
Evap. Water Flow rate - Maximum	(l/s)	59.1	66.9	76.1	83.4	92.5	101.1
Nominal water connection size (Grooved coupling)	(in) - (mm)	6" - 150	6" - 150	6" - 150	8" - 200	8" - 200	8" - 200
Hydraulic Module Components							
Standard head pressure pump option							
Available Head Pressure (1)	(kPa)	167	118	95	146	134	120
Max Motor Power input	(kW)	15	15	15	22	22	22
Max Amps	(A)	28	28	28	39.7	39.7	39.7
High head pressure pump option							
Available Head Pressure (1)	(kPa)	223	229	193	N/A	N/A	N/A
Max Motor Power input	(kW)	18.5	22	22	N/A	N/A	N/A
Max Amps	(A)	34.5	39.7	39.7	N/A	N/A	N/A
Expansion Tank Volume	(l)	80	160	160	160	160	160
Max User water loop Volume for factory mounted expansion tank (1)	(l)	4000	8000	8000	8000	8000	8000
Max. Water-side Operating Pressure without pump package	(kPa)	1000	1000	1000	1000	1000	1000
Max. Water-side Operating Pressure with pump package	(kPa)	450	450	450	450	450	450
Antifreeze Heater with pump package	(W)	3300	3400	3400	3600	3600	3600
Condenser							
Type		Full aluminum Micro channel heat exchanger					
Quantity	#	10/4	10/6	10/6	10/8	10/10	12/10
Face area per coil	(m ²)	2.4	2.4	2.4	2.4	2.4	2.4

General Data

Table 21a – General Data RTAF 250-410 High Seasonal Efficiency Short- Extra Low Noise - R134a - R513A (continued)

		RTAF 250	RTAF 280	RTAF 310	RTAF 350	RTAF 380	RTAF 410
		HSS XLN	HSS XLN	HSS XLN	HSS XLN	HSS XLN	HSS XLN
Condenser Fan							
Quantity	#	10/4	10/6	10/6	10/8	10/10	12/10
Diameter	(mm)	800	800	800	800	800	800
Standard / High ambient fan option							
Fan / motor Type		Propeller fan / Variable speed - EC motor					
Airflow per Fan	(m ³ /h)	20000	20000	20000	20000	20000	20500
Max Power input per Motor	(kW)	1.1	1.1	1.1	1.1	1.1	1.1
Max Amps per Motor	(A)	1.8	1.8	1.8	1.8	1.8	1.9
Motor RPM	(rpm)	860	860	860	860	860	885
Low ambient fan option							
Fan / motor Type		Propeller fan / Variable speed - EC motor					
Airflow per Fan	(m ³ /h)	20000	20000	20000	20000	20000	20500
Max Power input per Motor	(kW)	1.1	1.1	1.1	1.1	1.1	1.1
Max Amps per Motor	(A)	1.8	1.8	1.8	1.8	1.8	1.9
Motor RPM	(rpm)	860	860	860	860	860	885
System data (4)							
Nb of refrigerant circuit	#	2	2	2	2	2	2
Minimum cooling load % (6)	%	10	10	10	10	10	10
R134a/R513A refrigerant charge Circuit 1 / Circuit 2 (7)	(kg)	93/45	96/49	97/52	94/91	98/100	107/104
Oil charge Circuit 1 / Circuit 2	(l)	16/8	16/8	16/8	16/16	16/16	16/16
POE Oil type		OIL00317 or OIL00311					

- (1) Indicative performance at Evaporator water temperature: 12°C / 7°C - Condenser air temperature 35°C - for detailed performances consult Order Write Up.
(2) Under 400V/3/50Hz.
(3) Rated Condition without Pump Package.
(4) Electrical & system data are indicative and subject to change without notice. Please refer to unit nameplate data.
(5) Not applicable for Glycol application - see tables with Minimum Flow with Glycol.
(6) Max speed - range is 60% to 100% of max speed.
(7) Refrigerant charge may vary according to option - for instance +20% for process (digit 19=P). For real value refer to unit nameplate.
(8) Data containing information on two circuits shown as follows: ckt1/ckt2.

General Data

Table 21b –General Data RTAF 210-405 High Seasonal Efficiency Short - Extra Low Noise - R1234 ze

		RTAF 210	RTAF 230	RTAF 265	RTAF 275	RTAF 285	RTAF 300	RTAF 305	RTAF 340	RTAF 385	RTAF 405
		HSS XLN	HSS XLN	HSS XLN	HSS XLN	HSS XLN	HSS XLN	HSS XLN	HSS XLN	HSS XLN	HSS XLN
Cooling Capacity (1)	(kW)	725	806	886	997	996	1102	1081	1186	1307	1423
Unit amps (4) (5)											
Maximum power input in cooling	(kW)	379	421	425	468	511	515	554	558	605	652
Unit rated amps (Max compr+Fan+Control)	(A)	591	656	662	727	807	799	872	878	949	1021
Unit start up amps (Start up Amps of the largest compr+RLA of the 2nd compr+RLA of all fans+control)	(A)	741	806	812	877	957	949	1022	1028	1099	1171
Displacement Power Factor (DPF)		0.93	0.93	0.93	0.93	0.92	0.93	0.92	0.92	0.92	0.92
Max power cable cross section		4*185	4*185	4*185	4*185	4*185	4*185	4*185	4*185	4*185	6*185
Disconnect switch size	(A)	1250	1250	1250	1250	1250	1250	1250	1250	1250	1600
Compressor											
Compressor Number per Circuit	#	2	2	2	2	2	2	2	2	2	2
Type		Screw	Screw	Screw	Screw	Screw	Screw	Screw	Screw	Screw	Screw
Max Compr Power input Circuit1/ Circuit2	(kW)	65-78/ 65	78-78/ 78	78-78/ 78	78-78/ 78	65-78/ 65-78	78-78/ 78	78-78/ 78-78	78-78/ 78-78	78-78/ 78-78	78-78/ 78-78
Max Amps Circuit1 / Circuit 2 (3) (5)		112-125/ 112	134-125/ 134	134-125/ 134	155-125/ 155	112-125/ 112-125	179-125/ 179	134-125/ 134-125	134-125/ 134-125	155-125/ 155-125	179-125/ 179-125
Start up Amps Circuit1 / Circuit 2 (3)(5)	(A)	171-204/ 171	203-204/ 203	203-204/ 203	236-204/ 236	203-204/ 203-204	271-204/ 271	203-204/ 203-204	203-204/ 203-204	236-204/ 236-204	271-204/ 271-204
Locked Rotor Amps Circuit1 / Circuit 2 (4)	(A)	171-354/ 171	203-354/ 203	203-354/ 203	239-204/ 236	171-354/ 171-354	271-354/ 271	203-354/ 203-354	203-354/ 203-354	236-354/ 236-354	271-354/ 271-354
Motor maxRPM (variable speed)	(rpm)	3000	3000	3000	3000	3000	3000	3000	3000	3000	3000
Oil sump heater Circuit1 / Circuit 2	(W)	700	700	700	700	850	700	850	850	850	850
Evaporator											
Quantity	#	1	1	1	1	1	1	1	1	1	1
Type		Flooded shell and tube heat exchanger									
Evaporator model		300E	300D	300D	300B	500E	300B	500D	500D	500C	500B
Evaporator Water Content volume	(l)	86	97	97	108	130	108	146	146	159	170
Antifreeze Heater	(W)	2240	2240	2240	2240	2440	2240	2440	2440	2440	2440
Antifreeze Heater											
Evap. Water Flow rate - Maximum (6)	(l/s)	15.7	17.7	17.7	20.1	22.2	20.1	25.0	25.0	27.8	30.3
Evap. Water Flow rate - Maximum	(l/s)	58.5	65.8	65.8	74.5	82.6	74.5	92.8	92.8	103.0	112.5
Two pass evaporator with turbulator	(in) - (mm)	6" - 150	6" - 150	6" - 150	6" - 150	8" - 200	6" - 150	8" - 200	8" - 201	8" - 200	8" - 200
Nominal water connection size (Grooved coupling)											
Evap. Water Flow rate - Maximum (6)	(l/s)	13.2	14.8	14.8	16.7	18.5	16.7	20.8	20.8	23.1	25.3
Evap. Water Flow rate - Maximum	(l/s)	52.5	59.1	59.1	66.9	74.2	66.9	83.4	83.4	92.5	101.1
Nominal water connection size (Grooved coupling)	(in) - (mm)	6" - 150	6" - 150	6" - 150	6" - 150	8" - 200	6" - 150	8" - 200	8" - 201	8" - 200	8" - 200
Hydraulic Module Components											
Standard head pressure pump option (Twin pump)											
Max. Motor Power Input	(kPa)	N/A	N/A	N/A	N/A	N/A	N/A	N/A	N/A	N/A	N/A
Max. Motor Power	(kW)	11.0	11.0	15.0	15.0	15.0	15.0	15.0	22.0	22.0	22.0
High head pressure pump option (Twin pump)	(A)	20.8	20.8	29.0	29.0	29.0	29.0	29.0	39.7	39.7	39.7
High head pressure pump option (Twin pump)											
Max. Motor Power Input	(kPa)	N/A	N/A	N/A	N/A	N/A	N/A	N/A	N/A	N/A	N/A
Max. Amps	(kW)	18.5	18.5	22.0	22.0	22.0	22.0	22.0	0.0	0.0	0.0
Max. Rated Amps	(A)	34.5	34.5	39.7	39.7	39.7	39.7	39.7	0.0	0.0	0.0
Expansion Tank Volume	(l)	N/A	N/A	N/A	N/A	N/A	N/A	N/A	N/A	N/A	N/A
Max User water loop Volume for factory mounted expansion tank (1)	(l)	N/A	N/A	N/A	N/A	N/A	N/A	N/A	N/A	N/A	N/A
Max. Water-side Operating Pressure without pump package	(kPa)	N/A	N/A	N/A	N/A	N/A	N/A	N/A	N/A	N/A	N/A
Max. Water-side Operating Pressure with pump package	(kPa)	N/A	N/A	N/A	N/A	N/A	N/A	N/A	N/A	N/A	N/A
Antifreeze Heater with pump package	(W)	3300	3300	3400	3400	3600	3400	3600	3600	3600	3600
Condenser											
Type		Full aluminum Micro channel heat exchanger									
Quantity	#	10/4	10/4	10/6	10/6	10/8	10/6	10/8	10/10	12/10	12/10
Face area per coil	(m ²)	2.4	2.4	2.4	3.4	2.4	2.4	2.4	2.4	2.4	2.4
Condenser Fan											
Quantity	#	10/4	10/4	10/6	10/6	10/8	10/6	10/8	10/10	12/10	12/10
Diameter	(mm)	800	800	800	800	800	800	800	800	800	800

General Data

Table 21b –General Data RTAF 210-405 High Seasonal Efficiency Short - Extra Low Noise - R1234 ze (continued)

		RTAF 210	RTAF 230	RTAF 265	RTAF 275	RTAF 285	RTAF 300	RTAF 305	RTAF 340	RTAF 385	RTAF 405
		HSS XLN	HSS XLN	HSS XLN	HSS XLN	HSS XLN	HSS XLN	HSS XLN	HSS XLN	HSS XLN	HSS XLN
Standard / High ambient fan option											
Fan / motor Type		Propeller fan / Variable speed - EC motor									
Max Power Input per Motor	(m ³ /h)	20000	20000	20000	20000	20000	20000	20000	20000	20000	20000
Max Amps per Motor	(kW)	1.1	1.1	1.1	1.1	1.1	1.1	1.1	1.1	1.1	1.1
Motor RPM	(A)	1.8	1.8	1.8	1.8	1.8	1.8	1.8	1.8	1.8	1.8
Rated motor RPM	(rpm)	860	860	860	860	860	860	860	860	860	860
Standard / High ambient fan option											
Fan / motor Type		Propeller fan / Variable speed - EC motor									
Max Power Input per Motor	(m ³ /h)	20000	20000	20000	20000	20000	20000	20000	20000	20000	20000
Max Amps per Motor	(kW)	1.1	1.1	1.1	1.1	1.1	1.1	1.1	1.1	1.1	1.1
Motor RPM	(A)	1.8	1.8	1.8	1.8	1.8	1.8	1.8	1.8	1.8	1.8
Maximum ambient operation High ambient (8)	(°C)	860	860	860	860	860	860	860	860	860	860
System data (5)											
Minimum cooling load % (4) (7)	#	2	2	2	2	2	2	2	2	2	2
Minimum cooling load % (6)	%	15	15	15	15	15	15	15	15	15	15
Refrigerant charge Circuit 1 / Circuit 2	(kg)	90/40	93/44	93/49	96/51	90/88	96/51	94/91	94/96	106/100	107/104
Oil charge Circuit 1 / Circuit 2	(l)	13/7	13/7	13/7	13/7	13/13	13/7	13/13	13/13	13/13	13/13
POE Oil type (10)		OIL00317 or OIL00315									

(1) Indicative performance at Evaporator water temperature: 12°C / 7°C - Condenser air temperature 35°C - for detailed performances consult Order Write Up.

(2) Under 400V/3/50Hz.

(3) Rated Condition without Pump Package.

(4) Percent minimum load may be adjusted around 15%-20% according to operating conditions by local sales office.

(5) Electrical & system data are indicative and subject to change without notice. Please refer to unit nameplate data.

(6) Not applicable for Glycol application - see tables with Minimum Flow with Glycol.

(7) Max speed - range is 60% to 100% of max speed.

(8) Refrigerant charge may vary according to option - for instance +20% for process (digit 19 = p). For real value refer to unit nameplate.

(9) Data containing information on two circuits shown as follows: ckt1/ckt2.

(10) OIL0066E or OIL0067E may have been used on early orders and there is no restriction to continue to use them but preferable oil is OIL00315 or OIL00317.

General Data

Table 22a – General Data RTAF 250-550 High Seasonal Efficiency - Standard and Low Noise - R134a - R513A

		RTAF 250	RTAF 280	RTAF 310	RTAF 350	RTAF 370	RTAF 380	RTAF 400	RTAF 410	RTAF 450	RTAF 510	RTAF 550
		HSE SN LN	HSE SN LN	HSE SN LN	HSE SN LN	HSE SN LN	HSE SN LN	HSE SN LN	HSE SN LN	HSE SN LN	HSE SN LN	HSE SN LN
Cooling Capacity (1)	(kW)	880	997	1115	1243	1397	1354	1496	1473	1592	1801	1899
Unit electrical data (2) (3) (4)												
Maximum Power input in cooling	(kW)	379	429	491	535	641	585	641	631	651	813	813
Unit rated amps (Max compr +Fan+Control)	(A)	594	674	769	848	999	932	999	1003	1035	1287	1288
Unit start up amps (Starting Amps of the largest compr+RLA of 2nd compr+RLA of all fans+ control)	(A)	747	788	883	1001	1081	1046	1081	1117	1149	1369	1370
Displacement Power Factor (DPF)		0.92	0.92	0.92	0.91	0.93	0.91	0.93	0.91	0.91	0.91	0.91
Max power cable cross section	(mm ²)	4x185	4x185	4x185	4x185	4x185	4x185	4x185	4x185	6x185	6x185	6x185
Disconnect switch size	(A)	1250	1250	1250	1250	1250	1250	1250	1250	1600	1600	1600
Compressor												
Quantity	#	3	3	3	4	3	4	3	4	4	4	4
Type		Screw	Screw	Screw	Screw	Screw	Screw	Screw	Screw	Screw	Screw	Screw
Model (8)		85-85/ 70	85-100/ 85	100-100/ 100	85-85/ 85-85	140-115/ 140	85-100/ 85-100	160-115/ 160	100-100/ 100-100	120-100/ 120-100	140-115/ 140-115	160-115/ 160-115
Max Compr Power input Circuit 1/Circuit 2	kW	124-121/ 101	124-144/ 124	147-144/ 147	124-121/ 124-121	218-164/ 218	124-144/ 124-144	218-164/ 218	147-144/ 147-144	157-144/ 157-144	218-164/ 218-164	218-164/ 218-164
Max Amps Circuit 1 / Circuit 2 (3) (4)	(A)	188-201/ 153	188-240/ 188	224-240/ 224	188-201/ 188-201	331-273/ 331	188-240/ 188-240	331-273/ 331	224-240/ 224-240	238-240/ 238-240	331-273/ 331-273	331-273/ 331-273
Start up Amps Circuit 1 / Circuit 2 (3) (4)	(A)	188-354/ 153	188-354/ 188	224-354/ 224	188-354/ 188-354	331-354/ 331	188-354/ 188-354	331-354/ 331	224-354/ 224-354	238-354/ 238-354	331-354/ 331-354	331-354/ 331-354
Motor RPM	(rpm)	3000	3000	3000	3000	3600	3000	4200	3000	3000	3600	4200
Oil sump heater Circuit 1 / Circuit 2	(W)	300/150	300/150	300/150	300/300	300/300	300/300	300/300	300/300	300/300	300/300	300/300
Evaporator												
Quantity	#	1	1	1	1	1	1	1	1	1	1	1
Type		Flooded shell and tube heat exchanger										
Evaporator model		300D	300B	300A	500D	300A	500C	300A	500B	500B	500N	500N
Evaporator Water Content volume	(l)	97	108	120	146	120	159	120	170	170	188	188
Antifreeze Heater	(W)	2240	2240	2240	2440	2440	2440	2440	2440	2440	2440	2440
Two pass evaporator												
Evap. Water Flow rate - Minimum	(l/s)	17.7	20.1	22.8	25.0	25.0	27.8	27.8	30.3	30.3	30.3	30.3
Evap. Water Flow rate - Maximum (5)	(l/s)	65.8	74.5	84.8	92.8	92.8	103.0	103.0	112.5	112.5	112.5	112.5
Nominal water connection size (Grooved coupling)	(in) - (DN)	6" - 150	6" - 150	6" - 150	8" - 200	8" - 200	8" - 200	8" - 200	8" - 200	8" - 200	8" - 200	8" - 200
Two pass evaporator with turbulator												
Evap. Water Flow rate - Minimum (5)	(l/s)	14.8	16.7	19.0	20.8	20.8	23.1	23.1	25.3	25.3	25.3	25.3
Evap. Water Flow rate - Maximum	(l/s)	59.1	66.9	76.1	83.4	83.4	92.5	92.5	101.1	101.1	101.1	101.1
Nominal water connection size (Grooved coupling)	(in) - (mm)	6" - 150	6" - 150	6" - 150	8" - 200	8" - 200	8" - 200	8" - 200	8" - 200	8" - 200	8" - 200	8" - 200
Hydraulic Module Components												
Standard head pressure pump option (Twin pump)												
Available Head Pressure (1)	(kPa)	160	106	115	139	NA	127	NA	116	100	NA	NA
Max Motor Power input	(kW)	15	15	15	22	NA	22	NA	22	30	NA	NA
Max Amps	(A)	28	28	28	39.7	NA	39.7	NA	39.7	54.1	NA	NA
High head pressure pump option (Twin Pump)												
Available Head Pressure (1)	(kPa)	216	220	174	NA	NA	NA	NA	NA	NA	NA	NA
Max Motor Power input	(kW)	18.5	22	22	NA	NA	NA	NA	NA	NA	NA	NA
Max Amps	(A)	34.5	39.7	39.7	NA	NA	NA	NA	NA	NA	NA	NA
Expansion Tank Volume	(l)	80	160	160	160	NA	160	NA	160	160	NA	NA
Max User water loop Volume for factory mounted expansion tank (1)	(l)	4000	8000	8000	8000	NA	8000	NA	8000	8000	NA	NA
Max. Water-side Operating Pressure without pump package	(kPa)	1000	1000	1000	1000	NA	1000	NA	1000	1000	NA	NA
Max. Water-side Operating Pressure with pump package	(kPa)	450	450	450	450	NA	450	NA	450	450	NA	NA
Antifreeze Heater with pump package	(W)	3300	3400	3400	3600	3400	3600	3400	3600	3600	3600	3600



General Data

Table 22a – General Data RTAF 250-550 High Seasonal Efficiency - Standard and Low Noise - R134a - R513A (continued)

		RTAF 250	RTAF 280	RTAF 310	RTAF 350	RTAF 370	RTAF 380	RTAF 400	RTAF 410	RTAF 450	RTAF 510	RTAF 550
		HSE SN LN	HSE SN LN	HSE SN LN	HSE SN LN	HSE SN LN	HSE SN LN	HSE SN LN	HSE SN LN	HSE SN LN	HSE SN LN	HSE SN LN
Condenser												
Type		Full aluminum Micro channel heat exchanger										
Quantity	#	12/4	12/6	14/6	12/10	12/8	12/12	12/8	12/12	12/12	12/12	12/12
Face area per coil	(m ²)	2.4	2.4	2.4	2.4	2.4	2.4	2.4	2.4	2.4	2.4	2.4
Condenser Fan												
Quantity	#	12/4	12/6	14/6	12/10	12/8	12/12	12/8	12/12	12/12	12/12	12/12
Diameter	(mm)	800	800	800	800	800	800	800	800	800	800	800
Standard / High ambient fan option												
Fan / motor Type		Propeller fan / Variable Speed - EC motor										
Airflow per Fan	(m ³ /h)	20000	20000	20000	20000	20000	20000	20000	21500	22400	22400	22400
Max Power input per Motor	(kW)	1.3	1.3	1.3	1.3	1.3	1.3	1.3	1.4	1.5	1.5	1.5
Max Amps per Motor	(A)	2.3	2.3	2.3	2.3	2.3	2.3	2.3	2.5	2.6	2.6	2.6
Motor RPM	(rpm)	910	910	910	910	910	910	910	984	1020	1020	1020
Low ambient fan option												
Fan / motor Type		Propeller fan / Fixed Speed - EC motor										
Airflow per Fan	(m ³ /h)	20000	20000	20000	20000	20000	20000	20000	21500	22400	22400	22400
Max Power input per Motor	(kW)	1.3	1.3	1.3	1.3	1.3	1.3	1.3	1.4	1.5	1.5	1.5
Max Amps per Motor	(A)	2.3	2.3	2.3	2.3	2.3	2.3	2.3	2.5	2.6	2.6	2.6
Motor RPM	(rpm)	910	910	910	910	910	910	910	984	1020	1020	1020
System data (4)												
Nb of refrigerant circuit	#	2	2	2	2	2	2	2	2	2	2	2
Minimum cooling load % (4) (7)	%	10	10	10	10	10	10	10	10	10	10	10
R134a/R513A refrigerant charge Circuit 1 / Circuit 2 (7)	(kg)	108/43	104/53	112/54	102/96	112/54	103/108	112/54	107/110	107/110	140/140	140/140
Oil charge Circuit 1 / Circuit 2	(l)	16/8	16/8	16/8	16/16	16/16	16/16	16/16	16/16	16/16	16/16	16/16
POE Oil type		OIL00317 or OIL00311										

- (1) Indicative performance at Evaporator water temperature: 12°C / 7°C - Condenser air temperature 35°C - for detailed performances consult Order Write Up.
- (2) Under 400V/3/50Hz.
- (3) Rated Condition without Pump Package.
- (4) Electrical & system data are indicative and subject to change without notice. Please refer to unit nameplate data.
- (5) Not applicable for Glycol application - see tables with Minimum Flow with Glycol.
- (6) Max speed - range is 60% to 100% of max speed.
- (7) Refrigerant charge may vary according to option - for instance +20% for process (digit 19=P). For real value refer to unit nameplate.
- (8) Data containing information on two circuits shown as follows: ckt1/ckt2.

General Data

Table 22b – General Data RTAF 210-470 & 141-191 High Seasonal Efficiency- Standard and Low Noise - R1234 ze

		RTAF 210	RTAF 230	RTAF 265	RTAF 275	RTAF 285	RTAF 300	RTAF 305	RTAF 340	RTAF 385	RTAF 405	RTAF 470	RTAF 141	RTAF 191
		HSE SN LN	HSE SN LN	HSE SN LN	HSE SN LN	HSE SN LN	HSE SN LN	HSE SN LN	HSE SN LN	HSE SN LN	HSE SN LN	HSE SN LN	HSE SN LN	HSE SN LN
Net Cooling Capacity (1)	(kW)	732	828	896	1006	1112	1013	1105	1206	1317	1433	1694	Not suitable for comfort application	
Unit electrical data (2)														
(3) (5)														
Maximum Power input in cooling	(kW)	382	429	429	472	519	523	562	566	609	656	763	511	644
Unit rated amps (Max compr+Fan+Control)		597	668	668	733	819	811	884	890	955	1027	1161	793	1009
Unit start up amps (Starting Amps of the largest compr)	(A)	747	818	818	883	969	961	1034	1040	1105	1177	1161	943	1159
Displacement Power factor (DPF)	(A)	0.93	0.93	0.93	0.93	0.92	0.93	0.92	0.92	0.92	0.92	0.95	0.93	0.92
Max Power cable cross section	(mm ²)	4*185	4*185	4*185	4*185	4*185	4*185	4*185	4*185	4*185	6*185	6*185	4*185	6*185
Disconnect switch size	(A)	1250	1250	1250	1250	1250	1250	1250	1250	1250	1600	1600	1250	1600
Compressor														
Quantity	#	3	3	3	3	4	3	4	4	4	4	4	3	3
Type		Screw	Screw	Screw	Screw	Screw	Screw	Screw	Screw	Screw	Screw	Screw	Screw	Screw
Model (9)		65-78/ 65	78-78/ 78	78-78/ 78	78-78/ 78	65-78/ 65-78	78-78/ 78	78-78/ 78-78	78-78/ 78-78	78-78/ 78-78	78-78/ 78-78	78-78/ 78-78	78-78/ 78	78-78/ 78-78
Max Compr Power input Circuit 1 / Circuit 2	(kW)	112-125/ 112	134-125/ 134	134-125/ 134	155-125/ 155	112-125/ 112-125	179-125/ 179	134-125/ 134-125	134-125/ 134-125	155-125/ 155-125	179-125/ 125	179-179/ 179-179	179-125/ 179	179-125/ 179-125
Max Amps Circuit 1 / Circuit 2 (3) (4)		171-204/ 171	203-204: 203	203-204/ 203	236-204/ 236	203-204/ 203-204	271-204/ 271	203-204/ 203-204	203-204/ 203-204	236-204/ 236-204	271-204/ 271-204	271-271/ 271-271	271-204/ 271	271-204/ 271-204
Start up Amps Circuit 1 / Circuit 2 (3)(4)	(A)	171-354/ 171	203-354/ 203	203-354/ 203	239-204/ 236	171-354/ 171-354	271-354/ 271	203-354/ 203-354	203-354/ 203-354	236-354/ 236-354	271-354/ 271-354	271-271/ 271-271	271-354/ 271	271-354/ 271-354
Motor RPM	(rpm)	3000	3000	3000	3000	3000	3000	3000	3000	3000	3000	3000	3000	3000
Oil sump heater Circuit 1 / Circuit 2	(W)	700	700	700	700	850	700	850	850	850	850	850	700	850
Evaporator														
Quantity	#	1	1	1	1	1	1	1	1	1	1	1	1	1
Type		Flooded shell and tube heat exchanger												
Evaporator model		300E	300D	300D	300B	500E	300B	500D	500D	500C	500B	500N	300E	500E
Evaporator Water Content volume	(l)	86	97	97	108	130	108	146	146	159	170	188	86	130
Antifreeze Heater	(W)													
Two pass evaporator														
Evap. Water Flow rate - Maximum (6)	(l/s)	15.7	17.7	17.7	20.1	22.2	20.1	25.0	25.0	27.8	30.3	30.3	15.7	22.2
Evap. Water Flow rate - Maximum	(l/s)	58.5	65.8	65.8	74.5	82.6	74.5	92.8	92.8	103.0	112.5	112.5	58.5	82.6
Two pass evaporator with turbulator	(in) - (mm)	6" - 150	6" - 150	6" - 150	6" - 150	8" - 200	6" - 150	8" - 200	8" - 201	8" - 200	8" - 200	8" - 200	6" - 150	8" - 200
Two pass evaporator with turbulator														
Evap. Water Flow rate - Maximum (6)	(l/s)	13.2	14.8	14.8	16.7	18.5	16.7	20.8	20.8	23.1	25.3	25.3	13.2	18.5
Evap. Water Flow rate - Maximum	(l/s)	52.5	59.1	59.1	66.9	74.2	66.9	83.4	83.4	92.5	101.1	101.1	52.5	74.2
Nominal water connection size (Grooved coupling)	(in) - (mm)	6" - 150	6" - 150	6" - 150	6" - 150	8" - 200	6" - 150	8" - 200	8" - 201	8" - 200	8" - 200	8" - 200	6" - 150	8" - 200
Hydraulic Module Components														
Standard head pressure pump option (Twin pump)														
Max. Motor Power Input	(kPa)	N/A	N/A	N/A	N/A	N/A	N/A	N/A	N/A	N/A	N/A	N/A	N/A	N/A
Max. Motor Power	(kW)	11.0	11.0	15.0	15.0	15.0	15.0	15.0	22.0	22.0	22.0	0.0	15.0	15.0
High head pressure pump option (Twin pump)	(A)	20.8	20.8	29.0	29.0	29.0	29.0	29.0	39.7	39.7	39.7	0.0	29.0	29.0



General Data

Table 22b – General Data RTAF 210-470 & 141-191 High Seasonal Efficiency- Standard and Low Noise- R1234 ze (continued)

		RTAF 210	RTAF 230	RTAF 265	RTAF 275	RTAF 285	RTAF 300	RTAF 305	RTAF 340	RTAF 385	RTAF 405	RTAF 470	RTAF 141	RTAF 191
		HSE SN LN	HSE SN LN	HSE SN LN	HSE SN LN	HSE SN LN	HSE SN LN	HSE SN LN	HSE SN LN	HSE SN LN	HSE SN LN	HSE SN LN	HSE SN LN	HSE SN LN
High head pressure pump option (Twin pump)		N/A	N/A	N/A	N/A	N/A	N/A	N/A	N/A	N/A	N/A	N/A	N/A	N/A
Max. Motor Power Input	(kPa)	N/A	N/A	N/A	N/A	N/A	N/A	N/A	N/A	N/A	N/A	N/A	N/A	N/A
Max. Amps	(kW)	18.5	18.5	22.0	22.0	22.0	22.0	22.0	0.0	0.0	0.0	0.0	18.5	22.0
Max. Rated Amps	(A)	35	35	40	40	40	40	40	0	0	0	0	35	40
Expansion Tank Volume	(l)	N/A	N/A	N/A	N/A	N/A	N/A	N/A	N/A	N/A	N/A	N/A	N/A	N/A
Max User water loop Volume for factory mounted expansion tank (1)	(l)	N/A	N/A	N/A	N/A	N/A	N/A	N/A	N/A	N/A	N/A	N/A	N/A	N/A
Max. Water-side Operating Pressure without pump package	(kPa)	N/A	N/A	N/A	N/A	N/A	N/A	N/A	N/A	N/A	N/A	N/A	N/A	N/A
Max. Water-side Operating Pressure with pump package	(kPa)	N/A	N/A	N/A	N/A	N/A	N/A	N/A	N/A	N/A	N/A	N/A	N/A	N/A
Antifreeze Heater with pump package	(W)	3300	3300	3400	3400	3600	3400	3600	3600	3600	3600	3600	3300	3600
Condenser														
Type		Full aluminum Micro channel heat exchanger												
Quantity	#	12/4	12/6	12/6	12/6	12/10	12/8	12/10	12/12	12/12	12/12	12/12	10/4	10/8
Face area per coil	(m ²)	2.4	2.4	2.4	3.4	2.4	2.4	2.4	2.4	2.4	2.4	2.4	2.4	2.4
Condenser Fan														
Quantity	#	12/4	12/6	12/6	12/6	12/10	12/8	12/10	12/12	12/12	12/12	12/12	10/4	10/8
Diameter	(mm)	800	800	800	800	800	800	800	800	800	800	800	800	800
Standard / High ambient fan option														
Fan / motor Type		Propeller fan / Variable speed - EC motor												
Max Power Input per Motor	(m ³ /h)	20000	20000	20000	20000	20000	20000	20000	22400	20000	20000	22400	20000	20000
Max Amps per Motor	(kW)	1.3	1.3	1.3	1.3	1.3	1.3	1.3	1.5	1.3	1.3	1.5	1.3	1.3
Motor RPM	(A)	2.3	2.3	2.3	2.3	2.3	2.3	2.3	2.6	2.3	2.3	2.6	2.3	2.3
Rated motor RPM	(rpm)	910	910	910	910	910	910	910	1020	910	910	1020	910	910
Standard / High ambient fan option														
Fan / motor Type		Propeller fan / Variable speed - EC motor												
Airflow per Fan	(m ³ /h)	20000	20000	20000	20000	20000	20000	20000	22400	20000	20000	22400	20000	20000
Max Power input per Motor	(kW)	1.3	1.3	1.3	1.3	1.3	1.3	1.3	1.5	1.3	1.3	1.5	1.3	1.3
Max Amps per Motor	(A)	2.3	2.3	2.3	2.3	2.3	2.3	2.3	2.6	2.3	2.3	2.6	2.3	2.3
Motor RPM	(rpm)	910	910	910	910	910	910	910	1020	910	910	1020	910	910
System data (5)														
Nb of refrigerant circuit	#	2	2	2	2	2	2	2	2	2	2	2	2	2
Minimum cooling load % (4) (7)	%	15	15	15	15	15	15	15	15	15	15	15	15	15
Refrigerant charge Circuit 1 / Circuit 2	(kg)	98/40	104/49	104/49	108/51	100/92	108/53	102/96	102/102	108/108	107/110	112/110	102/35	98/95
Oil charge Circuit 1 / Circuit 2	(l)	13/7	13/7	13/7	13/7	13/13	13/7	13/13	13/13	13/13	13/13	13/13	13/13	13/13
POE Oil type (10)		OIL00317 or OIL00315												

- (1) Indicative performance at Evaporator water temperature: 12°C / 7°C - Condenser air temperature 35°C- for detailed performances consult Order Write Up.
- (2) Under 400V/3/50Hz.
- (3) Rated Condition without Pump Package.
- (4) Percent minimum load may be adjusted around 15%-20% according to operating conditions by local sales office.
- (5) Electrical & system data are indicative and subject to change without notice. Please refer to unit nameplate data.
- (6) Not applicable for Glycol application- see tables with Minimum Flow with Glycol.
- (7) Max speed- range is 60% to 100% of max speed.
- (8) Refrigerant charge may vary according to option- for instance +20% for process (digit 19 = p). For real value refer to unit nameplate.
- (9) Data containing information on two circuits shown as follows: ckt1/ckt2.
- (10) OIL0066E or OIL0067E may have been used on early orders and there is no restriction to continue to use them but preferable oil is OIL00315 or OIL00317.

General Data

Table 23a – General Data RTAF 250-550 High Seasonal Efficiency - Extra Low Noise - R134a - R513A

		RTAF 250	RTAF 280	RTAF 310	RTAF 350	RTAF 370	RTAF 380	RTAF 400	RTAF 410	RTAF 450	RTAF 510	RTAF 550
		HSE XLN	HSE XLN	HSE XLN	HSE XLN	HSE XLN	HSE XLN	HSE XLN	HSE XLN	HSE XLN	HSE XLN	HSE XLN
Cooling Capacity (1)	(kW)	879	997	1115	1243	1404	1354	1504	1463	1591	1810	1911
Unit electrical data (2) (3) (4)												
Maximum Power input in cooling	(kW)	379	429	491	535	641	585	641	631	651	813	813
Unit rated amps (Max compr +Fan+Control)	(A)	594	674	769	848	999	932	999	1003	1035	1287	1288
Unit start up amps (Starting Amps of the largest compr+RLA of 2nd compr+RLA of all fans+ control)	(A)	747	788	883	1001	1081	1046	1081	1117	1149	1369	1370
Displacement Power Factor (DPF)		0.92	0.92	0.92	0.91	0.93	0.91	0.93	0.91	0.91	0.91	0.91
Max power cable cross section	(mm ²)	4x185	4x185	4x185	4x185	4x185	4x185	4x185	4x185	6x185	6x185	6x185
Disconnect switch size	(A)	1250	1250	1250	1250	1250	1250	1250	1250	1600	1600	1600
Compressor												
Quantity	#	3	3	3	4	3	4	3	4	4	4	4
Type		Screw	Screw	Screw	Screw	Screw	Screw	Screw	Screw	Screw	Screw	Screw
Model (8)		85-85/ 70	85-100/ 85	100-100/ 100	85-85/ 85-85	140-115/ 140	85-100/ 85-100	160-115/ 160	100-100/ 100-100	120-100/ 120-100	140-115/ 140-115	160-115/ 160-115
Max Compr Power input Circuit 1/Circuit 2	(kW)	124-121/ 101	124-144/ 124	147-144/ 147	124-121/ 124-121	218-164/ 218	124-144/ 124-144	218-164/ 218	147-144/ 147-144	157-144/ 157-144	218-164/ 218-164	218-164/ 218-164
Max Amps Circuit 1 / Circuit 2 (3) (4)	(A)	188-201/ 153	188-240/ 188	224-240/ 224	188-201/ 188-201	331-273/ 331	188-240/ 188-240	331-273/ 331	224-240/ 224-240	238-240/ 238-240	331-273/ 331-273	331-273/ 331-273
Start up Amps Circuit 1 / Circuit 2 (3) (4)	(A)	188-354/ 153	188-354/ 188	224-354/ 224	188-354/ 188-354	331-354/ 331	188-354/ 188-354	331-354/ 331	224-354/ 224-354	238-354/ 238-354	331-354/ 331-354	331-354/ 331-354
Motor RPM	(rpm)	3000	3000	3000	3000	3600	3000	4200	3000	3000	3600	4200
Oil sump heater Circuit 1 / Circuit 2	(W)	300/150	300/150	300/150	300/300	300/300	300/300	300/300	300/300	300/300	300/300	300/300
Evaporator												
Quantity	#	1	1	1	1	1	1	1	1	1	1	1
Type		Flooded shell and tube heat exchanger										
Evaporator model		300D	300B	300A	500D	300A	500C	300A	500B	500B	500N	500N
Evaporator Water Content volume	(l)	97	108	120	146	120	159	120	170	170	188	188
Antifreeze Heater	(W)	2240	2240	2240	2440	2440	2440	2440	2440	2440	2440	2440
Two pass evaporator												
Evap. Water Flow rate - Minimum	(l/s)	17.7	20.1	22.8	25.0	22.8	27.8	22.8	30.3	30.3	30.3	30.3
Evap. Water Flow rate - Maximum (5)	(l/s)	65.8	74.5	84.8	92.8	84.8	103.0	84.8	112.5	112.5	112.5	112.5
Nominal water connection size (Grooved coupling)	(in) - (DN)	6" - 150	6" - 150	6" - 150	8" - 200	6" - 150	8" - 200	6" - 150	8" - 200	8" - 200	8" - 200	8" - 200
Two pass evaporator with turbulator												
Evap. Water Flow rate - Minimum (5)	(l/s)	14.8	16.7	19.0	20.8	19.0	23.1	19.0	25.3	25.3	25.3	25.3
Evap. Water Flow rate - Maximum	(l/s)	59.1	66.9	76.1	83.4	76.1	92.5	76.1	101.1	101.1	101.1	101.1
Nominal water connection size (Grooved coupling)	(in) - (mm)	6" - 150	6" - 150	6" - 150	8" - 200	6" - 150	8" - 200	6" - 150	8" - 200	8" - 200	8" - 200	8" - 200
Hydraulic Module Components												
Standard head pressure pump option (Twin pump)												
Available Head Pressure (1)	(kPa)	160	106	115	139	NA	127	NA	116	100	NA	NA
Max Motor Power input	(kW)	15	15	15	22	NA	22	NA	22	30	NA	NA
Max Amps	(A)	28	28	28	39.7	NA	39.7	NA	39.7	54.1	NA	NA
High head pressure pump option (Twin Pump)												
Available Head Pressure (1)	(kPa)	216	220	174	NA	NA	NA	NA	NA	NA	NA	NA
Max Motor Power input	(kW)	18.5	22	22	NA	NA	NA	NA	NA	NA	NA	NA
Max Amps	(A)	34.5	39.7	39.7	NA	NA	NA	NA	NA	NA	NA	NA
Expansion Tank Volume	(l)	80	160	160	160	NA	160	NA	160	160	NA	NA
Max User water loop Volume for factory mounted expansion tank (1)	(l)	4000	8000	8000	8000	NA	8000	NA	8000	8000	NA	NA
Max. Water-side Operating Pressure without pump package	(kPa)	1000	1000	1000	1000	NA	1000	NA	1000	1000	NA	NA
Max. Water-side Operating Pressure with pump package	(kPa)	450	450	450	450	NA	450	NA	450	450	NA	NA
Antifreeze Heater with pump package	(W)	3300	3400	3400	3600	3400	3600	3400	3600	3600	3600	3600

General Data

Table 23a – General Data RTAF 250-550 High Seasonal Efficiency - Extra Low Noise - R134a - R513A (continued)

		RTAF 250	RTAF 280	RTAF 310	RTAF 350	RTAF 370	RTAF 380	RTAF 400	RTAF 410	RTAF 450	RTAF 510	RTAF 550
		HSE XLN	HSE XLN	HSE XLN	HSE XLN	HSE XLN	HSE XLN	HSE XLN	HSE XLN	HSE XLN	HSE XLN	HSE XLN
Condenser												
Type		Full aluminum Micro channel heat exchanger										
Quantity	#	12/4	12/6	14/6	12/10	12/8	12/12	12/8	12/12	12/12	12/12	12/12
Face area per coil	(m ²)	2.4	2.4	2.4	2.4	2.4	2.4	2.4	2.4	2.4	2.4	2.4
Condenser Fan												
Quantity	#	12/4	12/6	14/6	12/10	12/8	12/12	12/8	12/12	12/12	12/12	12/12
Diameter	(mm)	800	800	800	800	800	800	800	800	800	800	800
Standard / High ambient fan option												
Fan / motor Type		Propeller fan / Variable Speed - EC motor										
Airflow per Fan	(m ³ /h)	20000	20000	20000	20000	20000	20000	20000	20500	22200	23700	23700
Max Power input per Motor	(kW)	1.1	1.1	1.1	1.1	1.1	1.1	1.1	1.1	1.2	1.3	1.3
Max Amps per Motor	(A)	1.8	1.8	1.8	1.8	1.8	1.8	1.8	1.9	2.0	2.1	2.1
Motor RPM	(rpm)	860	860	860	860	860	860	860	885	955	1020	1020
Low ambient fan option												
Fan / motor Type		Propeller fan / Variable Speed - EC motor										
Airflow per Fan	(m ³ /h)	20000	20000	20000	20000	20000	20000	20000	20500	22200	23700	23700
Max Power input per Motor	(kW)	1.1	1.1	1.1	1.1	1.1	1.1	1.1	1.1	1.2	1.3	1.3
Max Amps per Motor	(A)	1.8	1.8	1.8	1.8	1.8	1.8	1.8	1.9	2.0	2.1	2.1
Motor RPM	(rpm)	860	860	860	860	860	860	860	885	955	1020	1020
System data (4)												
Nb of refrigerant circuit	#	2	2	2	2	2	2	2	2	2	2	2
Minimum cooling load % (6)	%	10	10	10	10	10	10	10	10	10	10	10
R134a/R513A refrigerant charge Circuit 1 / Circuit 2 (7)	(kg)	108/43	104/53	112/54	102/96	112/54	103/108	112/54	107/110	107/110	140/140	140/140
Oil charge Circuit 1 / Circuit 2	(l)	16/8	16/8	16/8	16/16	16/8	16/16	16/8	16/16	16/16	16/16	16/16
POE Oil type		OIL00317 or OIL00311										

(1) Indicative performance at Evaporator water temperature: 12°C / 7°C - Condenser air temperature 35°C - for detailed performances consult Order Write Up.

(2) Under 400V/3/50Hz.

(3) Rated Condition without Pump Package.

(4) Electrical & system data are indicative and subject to change without notice. Please refer to unit nameplate data.

(5) Not applicable for Glycol application - see tables with Minimum Flow with Glycol.

(6) Max speed - range is 60% to 100% of max speed.

(7) Refrigerant charge may vary according to option - for instance +20% for process (digit 19=P). For real value refer to unit nameplate.

(8) Data containing information on two circuits shown as follows: ckt1/ckt2.

General Data

Table 23b – General Data RTAF 210-470 & 141-191 High Seasonal Efficiency- Extra Low Noise - R1234 ze

		RTAF 210	RTAF 230	RTAF 265	RTAF 275	RTAF 285	RTAF 300	RTAF 305	RTAF 340	RTAF 385	RTAF 405	RTAF 470	RTAF 141	RTAF 191
		HSE XLN	HSE XLN	HSE XLN	HSE XLN	HSE XLN	HSE XLN	HSE XLN	HSE XLN	HSE XLN	HSE XLN	HSE XLN	HSE XLN	HSE XLN
Cooling Capacity (1)	(kW)	731	826	895	1004	1012	1110	1103	1205	1315	1430	1698	Not suitable for comfort application	
Unit electrical data (2)														
(3) (4)														
Maximum power input in cooling	(kW)	382	429	429	472	519	523	562	566	609	656	763	511	644
Unit rated amps (Max compr+Fan+Control)	(A)	597	668	668	733	819	811	884	890	956	1027	1161	793	1009
Unit start up amps (Starting Amps of the largest compr+RLA of 2nd compr+RLA of all fans+control)	(A)	747	818	818	883	969	961	1034	1040	1105	1177	1161	943	1159
Displacement Power Factor (DPF)		0.93	0.93	0.93	0.93	0.92	0.93	0.92	0.92	0.92	0.92	0.95	0.93	0.92
Max power cable cross section	mm ²	4*185	4*185	4*185	4*185	4*185	4*185	4*185	4*185	4*185	6*185	6*185	4*185	6*185
Disconnect switch size	(A)	1250	1250	1250	1250	1250	1250	1250	1250	1250	1600	1600	1250	1600
Compressor														
Quantity	#	3	3	3	3	3	3	4	4	4	4	4	4	4
Type		Screw	Screw	Screw	Screw	Screw	Screw	Screw	Screw	Screw	Screw	Screw	Screw	Screw
Model (9)		65-78/ 65	78-78/ 78	78-78/ 78	78-78/ 78	65-78/ 65-78	78-78/ 78	78-78/ 78-78	78-78/ 78-78	78-78/ 78-78	78-78/ 78-78	78-78/ 78-78	78-78/ 78	78-78/ 78-78
Max compr Power input Circuit 1/ Circuit 2	(kW)	112-125/ 112	134-125/ 134	134-125/ 134	155-125/ 155	112-125/ 112-125	179-125/ 179	134-125/ 134-125	134-125/ 134-125	155-125/ 155-125	179-125/ 179-125	179-125/ 179-125	179-125/ 179-125	179-125/ 179-125
Max Amps Circuit1 / Circuit 2 (3)(5)	(A)	171-204/ 171	203-204/ 203	203-204/ 203	236-204/ 236	203-204/ 203-204	271-204/ 271	203-204/ 203-204	203-204/ 203-204	236-204/ 236-204	271-204/ 271-204	271-204/ 271-204	271-204/ 271	271-204/ 271-204
Startup Amps Circuit 1/Circuit 2	(A)	171-354/ 171	203-354/ 203	203-354/ 203	239-204/ 236	171-354/ 171-354	271-354/ 271	203-354/ 203-354	203-354/ 203-354	236-354/ 236-354	271-354/ 271-354	271-271/ 271-271	271-354/ 271	271-354/ 271-354
Motor RPM	(rpm)	3000	3000	3000	3000	3000	3000	3000	3000	3000	3000	3000	3000	3000
Oil sump heater Circuit1 / Circuit 2	(W)	700	700	700	700	850	700	850	850	850	850	850	700	850
Evaporator														
Quantity	#	1	1	1	1	1	1	1	1	1	1	1		
Type		Flooded shell and tube heat exchanger												
Evaporator model		300E	300D	300D	300B	500E	300B	500D	500D	500C	500B	500N	300E	500E
Evaporator Water Content volume	(l)	86	97	97	108	130	108	146	146	159	170	188	86	130
Antifreeze heater	(W)													
Two pass evaporator														
Evap. Water Flow rate - Minimum	(l/s)	15.7	17.7	17.7	20.1	22.2	20.1	25.0	25.0	27.8	30.3	30.3	15.7	22.2
Evap. Water Flow rate - Maximum (6)	(l/s)	58.5	65.8	65.8	74.5	82.6	74.5	92.8	92.8	103.0	112.5	112.5	58.5	85.6
Two pass evaporator with turbulator	(in) - (mm)	6" - 150	6" - 150	6" - 150	6" - 150	8" - 200	6" - 150	8" - 200	8" - 201	8" - 200	8" - 200	8" - 200	6" - 150	8" - 200
Nominal water connection size (Grooved coupling)														
Evap. Water Flow rate - Minimum	(l/s)	13.2	14.8	14.8	16.7	18.5	16.7	20.8	20.8	23.1	25.3	25.3	13.2	18.5
Evap. Water Flow rate - Maximum (6)	(l/s)	52.5	59.1	59.1	66.9	74.2	66.9	83.4	83.4	92.5	101.1	101.1	52.5	74.2
Nominal water connection size (Grooved coupling)	(in) - (mm)	6" - 150	6" - 150	6" - 150	6" - 150	8" - 200	6" - 150	8" - 200	8" - 201	8" - 200	8" - 200	8" - 200	6" - 150	8" - 200
Hydraulic Module Components														
Standard head pressure pump option (Twin pump)														
Max. Motor Power Input	(kPa)	N/A	N/A	N/A	N/A	N/A	N/A	N/A	N/A	N/A	N/A	N/A	N/A	N/A
Max. Motor Power	(kW)	11.0	11.0	15.0	15.0	15.0	15.0	15.0	22.0	22.0	22.0	0.0	15.0	15.0
High head pressure pump option (Twin pump)	(A)	20.8	20.8	29.0	29.0	29.0	29.0	29.0	39.7	39.7	39.7	0.0	29.0	29.0



General Data

Table 23b – General Data RTAF 210-470 & 141-191 High Seasonal Efficiency- Extra Low Noise- R1234 ze (continued)

		RTAF 210	RTAF 230	RTAF 265	RTAF 275	RTAF 285	RTAF 300	RTAF 305	RTAF 340	RTAF 385	RTAF 405	RTAF 470	RTAF 141	RTAF 191
		HSE XLN	HSE XLN	HSE XLN	HSE XLN	HSE XLN	HSE XLN	HSE XLN	HSE XLN	HSE XLN	HSE XLN	HSE XLN	HSE XLN	HSE XLN
High head pressure pump option (Twin pump)		N/A	N/A	N/A	N/A	N/A	N/A	N/A	N/A	N/A	N/A	N/A	N/A	N/A
Max. Motor Power Input	(kPa)	N/A	N/A	N/A	N/A	N/A	N/A	N/A	N/A	N/A	N/A	N/A	N/A	N/A
Max. Amps	(kW)	18.5	18.5	22.0	22.0	22.0	22.0	22.0	0.0	0.0	0.0	0.0	18.5	22.0
Max. Rated Amps	(A)	35	35	40	40	40	40	40	0	0	0	0	35	40
Expansion Tank Volume	(l)	N/A	N/A	N/A	N/A	N/A	N/A	N/A	N/A	N/A	N/A	N/A	N/A	N/A
Max User water loop Volume for factory mounted expansion tank (1)	(l)	N/A	N/A	N/A	N/A	N/A	N/A	N/A	N/A	N/A	N/A	N/A	N/A	N/A
Max. Water-side Operating Pressure without pump package	(kPa)	N/A	N/A	N/A	N/A	N/A	N/A	N/A	N/A	N/A	N/A	N/A	N/A	N/A
Max. Water-side Operating Pressure with pump package	(kPa)	N/A	N/A	N/A	N/A	N/A	N/A	N/A	N/A	N/A	N/A	N/A	N/A	N/A
Antifreeze Heater with pump package	(W)	3300	3300	3400	3400	3600	3400	3600	3600	3600	3600	3600	3300	3600
Condenser														
Type		Full aluminum Micro channel heat exchanger												
Quantity	#	12/4	12/6	12/6	12/6	12/10	12/8	12/10	12/12	12/12	12/12	12/12	10/4	10/8
Face area per coil	(m ²)	2.4	2.4	2.4	3.4	2.4	2.4	2.4	2.4	2.4	2.4	2.4	2.4	2.4
Condenser Fan														
Quantity	#	12/4	12/6	12/6	12/6	12/10	12/8	12/10	12/12	12/12	12/12	12/12	10/4	10/8
Diameter	(mm)	800	800	800	800	800	800	800	800	800	800	800	800	800
Standard / High ambient fan option														
Fan / motor Type		Propeller fan / Variable speed - EC motor												
Max Power Input per Motor	(m ³ /h)	20000	20000	20000	20000	20000	20000	20000	20000	20000	20000	20000	22400	20000
Max Amps per Motor	(kW)	1.3	1.3	1.3	1.3	1.3	1.3	1.3	1.3	1.3	1.3	1.5	1.3	1.3
Motor RPM	(A)	2.3	2.3	2.3	2.3	2.3	2.3	2.3	2.3	2.3	2.3	2.6	2.3	2.3
Rated motor RPM	(rpm)	910	910	910	910	910	910	910	910	910	910	1020	910	910
Standard / High ambient fan option														
Fan / motor Type		Propeller fan / Variable speed - EC motor												
Max Power Input per Motor	(m ³ /h)	20000	20000	20000	20000	20000	20000	20000	20000	20000	20000	20000	22400	20000
Max Amps per Motor	(kW)	1.3	1.3	1.3	1.3	1.3	1.3	1.3	1.3	1.3	1.3	1.5	1.3	1.3
Motor RPM	(A)	2.3	2.3	2.3	2.3	2.3	2.3	2.3	2.3	2.3	2.3	2.6	2.3	2.3
Maximum ambient operation High ambient (8)	(°C)	910	910	910	910	910	910	910	910	910	910	1020	910	910
System data (5)														
Nb of refrigerant circuit	#	2	2	2	2	2	2	2	2	2	2	2	2	2
Minimum cooling load % (4) (7)	%	15	15	15	15	15	15	15	15	15	15	15	15	15
Refrigerant charge Circuit 1 / Circuit 2 (8)	(kg)	98/40	104/49	104/49	108/51	100/92	108/53	102/96	102/102	108/108	107/110	112/110	102/35	98/95
Oil charge Circuit 1 / Circuit 2	(l)	13/7	13/7	13/7	13/7	13/13	13/7	13/13	13/13	13/13	13/13	13/13	13/13	13/13
POE Oil type (10)		OIL00317 or OIL00315												

(1) Indicative performance at Evaporator water temperature: 12°C / 7°C- Condenser air temperature 35°C- for detailed performances consult Order Write Up.

(2) Under 400V/3/50Hz.

(3) Rated Condition without Pump Package.

(4) Percent minimum load may be adjusted around 15%-20% according to operating conditions by local sales office.

(5) Electrical & system data are indicative and subject to change without notice. Please refer to unit nameplate data.

(6) Not applicable for Glycol application- see tables with Minimum Flow with Glycol.

(7) Max speed- range is 60% to 100% of max speed.

(8) Refrigerant charge may vary according to option- for instance +20% for process (digit 19 = p). For real value refer to unit nameplate.

(9) Data containing information on two circuits shown as follows: ckt1/ckt2.

(10) OIL0066E or OIL0067E may have been used on early orders and there is no restriction to continue to use them but preferable oil is OIL00315 or OIL00317.

General Data

Table 24 – General Data RTAF 100-330 Extra Seasonal Efficiency – Standard Noise and Low Noise – R134a

		RTAF 100	RTAF 165	RTAF 200	RTAF 265	RTAF 330
		XSE-SN LN	XSE-SN LN	XSE-SN LN	XSE-SN LN	XSE-SN LN
Cooling Capacity (1)	(kW)	369	589	729	984	1223
Unit electrical data (2) (3) (4)						
Maximum power input in cooling	(kW)	143	237	273	371	470
Unit rated amps (Max compr+Fan+Control)	(A)	218	362	416	566	715
Unit start up amps (Starting Amps of the larges compr+RLA of 2nd compr+RLA of all fans+control)	(A)	218	362	416	566	715
Displacement Power Factor (DPF)		0.94	0.95	0.95	0.95	0.95
Max power cable cross section	(mm ²)	2*300	2*300	2*300	4*185	4*185
Disconnect switch size	(A)	630	630	630	1250	1250
Compressor						
Quantity	#	1	1	2	2	2
Type		Screw	Screw	Screw	Screw	Screw
Model (9)		100 / 0	165 / 0	100 / 100	100 / 165	165 / 165
Max Compressor power input circuit1/circuit 2	(A)	122 / 0	213 / 0	122 / 122	122 / 213	213 / 213
Max Amps Circuit1 / Circuit 2	(A)	186 / 0	323 / 0	186 / 186	186 / 323	323 / 323
Startup Amps Circuit 1/Circuit 2		186 / 0	323 / 0	186 / 186	186 / 323	323 / 323
Motor RPM (variable speed)	(rpm)	5800	5250	5800-5800	5800-5250	5250-5250
Oil sump heater Circuit1 / Circuit 2	(W)	340	340	550	550	550
Evaporator						
Quantity	#	1	1	1	1	1
Type		Flooded Shell and Tube Heat Exchanger				
Evaporator model		166D	166C	200A	330B	330B
Evaporator Water Content volume	(I)	57	66	105	110	110
Antifreeze heater	(W)	1640	1640	2040	2040	2040
Evaporator						
Evap. Water Flow rate - Minimum	(l/s)	8.7	10.7	15.3	20.1	20.1
Evap. Water Flow rate - Maximum (6)	(l/s)	32.1	39.5	56.6	74.5	74.5
Nominal water connection size (Grooved coupling)	(in) - (mm)	5" - 125	5" - 125	6" - 150	6" - 150	6" - 150
Evaporator with turbulators						
Evap. Water Flow rate - Minimum	(l/s)	7.2	8.9	12.7	16.7	16.7
Evap. Water Flow rate - Maximum	(l/s)	28.8	35.4	50.8	66.9	66.9
Nominal water connection size (Grooved coupling)	(in) - (mm)	5" - 125	5" - 125	6" - 150	6" - 150	6" - 150
Hydraulic Module Components						
Standard head pressure pump option (Twin pump)						
Available Head Pressuret	(kPa)	143	143	143	118	140
Max Motor Power input	(kW)	5.5	11.0	11.0	15.0	22.0
Max Amps	(A)	11	21	21	28	40
High head pressure pump option (Twin Pump)						
Available Head Pressuret	(kPa)	183	205	254	220	174
Max Motor Power input	(kW)	11	15	19	22	0
Max Amps	(A)	21	28	35	40	0
Expansion Tank Volume	(I)	80	80	80	80	80
Max User water loop Volume for factory mounted expansion tank (1)	(I)	6000	6000	6000	6000	6000
Max. Water-side Operating Pressure without pump package	(kPa)	1000	1000	1000	1000	1000
Max. Water-side Operating Pressure with pump package	(kPa)	450	450	450	450	450
Antifreeze Heater with pump package	(kPa)	2400	2400	2400	2400	2400
Condenser						
Type		Full aluminum Micro channel heat exchanger				
Quantity	#	10	12	7/7	8/10	12/10
Face area per coil	(m ²)	2.4	2.4	2.4	2.4	2.4
Condenser Fan (nominal conditions)						
Quantity	#	10	12	7/7	8/10	12/10
Diameter	(mm)	800	800	800	800	800
Standard fan						
Fan / motor Type		Propeller fan / Variable speed - EC motor				
Airflow per Fan	(m ³ /h)	20000	20000	20000	20000	20000
Power per Motor	(kW)	1.3	1.3	1.3	1.3	1.3
Rated Amps per Motor	(A)	2.3	2.3	2.3	2.3	2.3
Rated motor RPM	(rpm)	910	910	910	910	910

Table 24 – General Data RTAF 100-330 Extra Seasonal Efficiency – Standard Noise and Low Noise – R134a (continued)

		RTAF 100 XSE-SN LN	RTAF 165 XSE-SN LN	RTAF 200 XSE-SN LN	RTAF 265 XSE-SN LN	RTAF 330 XSE-SN LN
Dimensions						
Unit Length	(mm)	5645	6770	7895	10145	12395
Unit Width	(mm)	2220	2220	2220	2220	2220
Unit Height	(mm)	2526	2526	2526	2526	2526
Weights						
Shipping Weight(5)	(kg)	3450	4065	5275	6790	7730
Operating Weight(5)	(kg)	3520	4150	5405	6940	7900
Operating limits						
Minimum Starting/Operating Ambient (7)						
Standard ambient unit	(°C)	-10	-10	-10	-10	-10
Low Ambient (Option)	(°C)	-20	-20	-20	-20	-20
Maximum ambient operation Standard ambient (8)	(°C)	46	46	46	46	46
Maximum ambient operation High ambient (8)	(°C)	Not available	Not available	Not available	Not available	Not available
System data						
Nb of refrigerant circuit	#	1	1	2	2	2
Minimum cooling load % (6)	%	30	30	15	15	15
Standard unit						
R134a refrigerant charge Circuit1 / Circuit 2	(kg)	79	93	68/66	78/86	93/86
Oil charge Circuit1 / Circuit 2	(l)	11.5	13.5	11.5/11.5	11.5/13.5	13.5/13.5
Brine application unit						
R134a refrigerant charge Circuit1 / Circuit 2	(kg)	91	107	78/76	90/99	107/99
Oil charge Circuit1 / Circuit 2	(l)	13.0	15.0	13/13	13/15	15/15
Type				OIL00317 or OIL00311		

(1) Indicative performance at Evaporator water temperature: 12°C / 7°C- Condenser air temperature 35°C- for detailed performances consult Order Write Up.

(2) Under 400V/3/50Hz.

(3) Rated Condition without Pump Package.

(4) Percent minimum load may be adjusted around 15%-20% according to operating conditions by local sales office.

(5) Electrical & system data are indicative and subject to change without notice. Please refer to unit nameplate data.

(6) Not applicable for Glycol application- see tables with Minimum Flow with Glycol.

(7) Max speed- range is 60% to 100% of max speed.

(8) Refrigerant charge may vary according to option- for instance +20% for process (digit 19 = p). For real value refer to unit nameplate.

(9) Data containing information on two circuits shown as follows: ckt1/ckt2.

Table 25 – General Data RTAF 100-330 Extra Seasonal Efficiency – Extra Low Noise – R134a

		RTAF 100 XSE-XLN	RTAF 165 XSE-XLN	RTAF 200 XSE-XLN	RTAF 265 XSE-XLN	RTAF 330 XSE-XLN
Cooling Capacity (1)	(kW)	369	589	729	984	1223
Unit electrical data (2) (3) (4)						
Maximum power input in cooling	(kW)	143	237	273	371	470
Unit rated amps (Max compr+Fan+Control)	(A)	218	362	416	566	715
Unit start up amps (Starting Amps of the larges compr+RLA of 2nd compr+RLA of all fans+control)	(A)	218	362	416	566	715
Displacement Power Factor (DPF)		0.94	0.95	0.95	0.95	0.95
Max power cable cross section	(mm2)	2*300	2*300	2*300	4*185	4*185
Disconnect switch size	(A)	630	630	630	1250	1250
Compressor						
Quantity	#	1	1	2	2	2
Type		Screw	Screw	Screw	Screw	Screw
Model (9)		100 / 0	165 / 0	100 / 100	100 / 165	165 / 165
Max Compressor power input circuit1/circuit 2	(A)	122 / 0	213 / 0	122 / 122	122 / 213	213 / 213
Max Amps Circuit1 / Circuit 2	(A)	186 / 0	323 / 0	186 / 186	186 / 323	323 / 323
Startup Amps Circuit 1/Circuit 2		186 / 0	323 / 0	186 / 186	186 / 323	323 / 323
Motor max RPM (variable speed)	(rpm)	5800	5250	5800-5800	5800-5250	5250-5250
Oil sump heater Circuit1 / Circuit 2	(W)	340	340	550	550	550
Evaporator						
Quantity	#	1	1	1	1	1
Type		Flooded Shell and Tube Heat Exchanger				
Evaporator model		166D	166C	200A	330B	330B
Evaporator Water Content volume	(l)	57	66	105	110	110
Antifreeze heater	(W)	1640	1640	2040	2040	2040
Evaporator						
Evap. Water Flow rate - Minimum	(l/s)	8.7	10.7	15.3	20.1	20.1
Evap. Water Flow rate - Maximum (6)	(l/s)	32.1	39.5	56.6	74.5	74.5
Nominal water connection size (Grooved coupling)	(in) - (mm)	5" - 125	5" - 125	6" - 150	6" - 150	6" - 150
Evaporator with turbulators						
Evap. Water Flow rate - Minimum	(l/s)	7.2	8.9	12.7	16.7	16.7
Evap. Water Flow rate - Maximum	(l/s)	28.8	35.4	50.8	66.9	66.9
Nominal water connection size (Grooved coupling)	(in) - (mm)	5" - 125	5" - 125	6" - 150	6" - 150	6" - 150
Hydraulic Module Components						
Standard head pressure pump option (Twin pump)						
Available Head Pressure	(kPa)	143	143	143	118	140
Max Motor Power input	(kW)	6	11	11	15	22
Max Amps	(A)	11	21	21	28	40
High head pressure pump option (Twin Pump)						
Available Head Pressure	(kPa)	183	205	254	220	174
Max Motor Power input	(kW)	11	15	19	22	0
Max Amps	(A)	21	28	35	40	0
Expansion Tank Volume	(A)	21	28	35	40	0
Max User water loop Volume for factory mounted expansion tank (1)	(l)	6000	6000	6000	6000	6000
Max. Water-side Operating Pressure without pump package	(kPa)	1000	1000	1000	1000	1000
Max. Water-side Operating Pressure with pump package	(kPa)	450	450	450	450	450
Antifreeze Heater with pump package	(kPa)	2400	2400	2400	2400	2400
Condenser						
Type		Full aluminum Micro channel heat exchanger				
Quantity	#	10	12	7/7	8/10	12/10
Face area per coil	(m ²)	2.4	2.4	2.4	2.4	2.4
Condenser Fan (nominal conditions)						
Quantity	#	10	12	7/7	8/10	12/10
Diameter	(mm)	800	800	800	800	800
Standard fan						
Fan / motor Type		Propeller fan / Variable speed - AC motor				
Airflow per Fan	(m3/h)	20000	20000	20000	20000	20000
Power per Motor	(kW)	1.1	1.1	1.1	1.1	1.1
Rated Amps per Motor	(A)	1.8	1.8	1.8	1.8	1.8
Rated motor RPM	(rpm)	860	860	860	860	860

Table 25 – General Data RTAF 100-330 Extra Seasonal Efficiency – Extra Low Noise – R134a (continued)

		RTAF 100 XSE-XLN	RTAF 165 XSE-XLN	RTAF 200 XSE-XLN	RTAF 265 XSE-XLN	RTAF 330 XSE-XLN
Dimensions						
Unit Length	(mm)	5645	6770	7895	10145	12395
Unit Width	(mm)	2220	2220	2220	2220	2220
Unit Height	(mm)	2526	2526	2526	2526	2526
Weights						
Shipping Weight(5)	(kg)	3600	4235	5515	7070	8030
Operating Weight(5)	(kg)	3670	4320	5645	7220	8200
Operating Limits						
Minimum Starting/Operating Ambient (7)						
Standard ambient unit	(°C)	-10	-10	-10	-10	-10
Low Ambient (Option)	(°C)	-20	-20	-20	-20	-20
Maximum ambient operation Standard ambient (8)	(°C)	46	46	46	46	46
Maximum ambient operation High ambient (8)	(°C)	Not available	Not available	Not available	Not available	Not available
System data						
Nb of refrigerant circuit	#	1	1	2	2	2
Minimum cooling load % (6)	%	30	30	15	15	15
Standard unit						
R134a refrigerant charge Circuit1 / Circuit 2	(kg)	79	93	68/66	78/86	93/86
Oil charge Circuit1 / Circuit 2	(l)	11.5	13.5	11.5/11.5	11.5/13.5	13.5/13.5
Brine application unit						
R134a refrigerant charge Circuit1 / Circuit 2	(kg)	91	107	78/76	90/99	107/99
Oil charge Circuit1 / Circuit 2	(l)	13.0	15.0	13/13	13/15	15/15
Type		OIL00317 or OIL00311				

(1) Indicative performance at Evaporator water temperature: 12°C / 7°C- Condenser air temperature 35°C- for detailed performances consult Order Write Up.

(2) Under 400V/3/50Hz.

(3) Rated Condition without Pump Package.

(4) Percent minimum load may be adjusted around 15%-20% according to operating conditions by local sales office.

(5) Electrical & system data are indicative and subject to change without notice. Please refer to unit nameplate data.

(6) Not applicable for Glycol application- see tables with Minimum Flow with Glycol.

(7) Max speed- range is 60% to 100% of max speed.

(8) Refrigerant charge may vary according to option- for instance +20% for process (digit 19 = p). For real value refer to unit nameplate.

(9) Data containing information on two circuits shown as follows: ckt1/ckt2.

Table 26 – General Data RTAF 100-330 Extra Seasonal Efficiency – Whisper Low Noise – R134a

		RTAF 100	RTAF 165	RTAF 200	RTAF 265	RTAF 330
		XSE-WLN	XSE-WLN	XSE-WLN	XSE-WLN	XSE-WLN
Cooling Capacity (1)	(kW)	345	552	691	914	1110
Unit electrical data (2) (3) (4)						
Maximum power input in cooling	(kW)	134	229	264	358	456
Unit rated amps (Max compr+Fan+Control)	(A)	212	358	414	560	713
Unit start up amps (Starting Amps of the larges compr+RLA of 2nd compr+RLA of all fans+control)	(A)	212	358	414	560	713
Displacement Power Factor (DPF)		0.94	0.95	0.95	0.95	0.95
Max power cable cross section	(mm ²)	2*300	2*300	2*300	4*185	4*185
Disconnect switch size	(A)	630	630	630	1250	1250
Compressor						
Quantity	#	1	1	2	2	2
Type		Screw	Screw	Screw	Screw	Screw
Model (9)		100 / 0	165 / 0	100 / 100	100 / 165	165 / 165
Max Compressor power input circuit1/circuit 2	(A)	122 / 0	213 / 0	122 / 122	122 / 213	213 / 213
Max Amps Circuit1 / Circuit 2	(A)	186 / 0	323 / 0	186 / 186	186 / 323	323 / 323
Startup Amps Circuit 1/Circuit 2		186 / 0	323 / 0	186 / 186	186 / 323	323 / 323
Motor RPM (variable speed)	(rpm)	5800	5250	5800-5800	5800-5250	5250-5250
Oil sump heater Circuit1 / Circuit 2	(W)	340	340	550	550	550
Evaporator						
Quantity	#	1	1	1	1	1
Type		Flooded Shell and Tube Heat Exchanger				
Evaporator model		166D	166C	200A	330B	330B
Evaporator Water Content volume	(l)	57	66	105	110	110
Antifreeze heater	(W)	1640	1640	2040	2040	2040
Evaporator						
Evap. Water Flow rate - Minimum	(l/s)	8.7	10.7	15.3	20.1	20.1
Evap. Water Flow rate - Maximum (6)	(l/s)	32.1	39.5	56.6	74.5	74.5
Nominal water connection size (Grooved coupling)	(in) - (mm)	5" - 125	5" - 125	6" - 150	6" - 150	6" - 150
Evaporator with turbulators						
Evap. Water Flow rate - Minimum	(l/s)	7.2	8.9	12.7	16.7	16.7
Evap. Water Flow rate - Maximum	(l/s)	28.8	35.4	50.8	66.9	66.9
Nominal water connection size (Grooved coupling)	(in) - (mm)	5" - 125	5" - 125	6" - 150	6" - 150	6" - 150
Hydraulic Module Components						
Standard head pressure pump option (Twin pump)						
Available Head Pressure	(kPa)	143	143	143	118	140
Max Motor Power input	(kW)	5.5	11	11	15	22
Max Amps	(A)	11	21	21	28	40
High head pressure pump option (Twin Pump)						
Available Head Pressure	(kPa)	183	205	254	220	174
Max Motor Power input	(kW)	11	15	19	22	0
Max Amps	(A)	21	28	35	40	0
Expansion Tank Volume	(l)	80	80	80	80	80
Max User water loop Volume for factory mounted expansion tank (1)	(l)	6000	6000	6000	6000	6000
Max. Water-side Operating Pressure without pump package	(kPa)	1000	1000	1000	1000	1000
Max. Water-side Operating Pressure with pump package	(kPa)	450	450	450	450	450
Antifreeze Heater with pump package	(kPa)	2400	2400	2400	2400	2400
Condenser						
Type		Full aluminum Micro channel heat exchanger				
Quantity	#	10	12	7/7	8/10	12/10
Face area per coil	(m ²)	2.4	2.4	2.4	2.4	2.4
Condenser Fan (nominal conditions)						
Quantity	#	10	12	7/7	8/10	12/10
Diameter	(mm)	800	800	800	800	800
Standard fan						
Fan / motor Type		Propeller fan / Variable speed - AC motor				
Airflow per Fan	(m ³ /h)	20000	20000	20000	20000	20000
Power per Motor	(kW)	1.1	1.1	1.1	1.1	1.1
Rated Amps per Motor	(A)	1.8	1.8	1.8	1.8	1.8
Rated motor RPM	(rpm)	860	860	860	860	860

Table 26 – General Data RTAF 100-330 Extra Seasonal Efficiency – Whisper Low Noise – R134a (continued)

		RTAF 100	RTAF 165	RTAF 200	RTAF 265	RTAF 330
		XSE-WLN	XSE-WLN	XSE-WLN	XSE-WLN	XSE-WLN
Dimensions						
Unit Length	(mm)	5645	6770	7895	10145	12395
Unit Width	(mm)	2220	2220	2220	2220	2220
Unit Height	(mm)	2526	2526	2526	2526	2526
Weights						
Shipping Weight(5)	(kg)	3720	4355	5755	7310	8270
Operating Weight(5)	(kg)	3790	4440	5885	7460	8440
Operating Limits						
Minimum Starting/Operating Ambient (7)						
Standard ambient unit	(°C)	-10	-10	-10	-10	-10
Low Ambient (Option)	(°C)	-20	-20	-20	-20	-20
Maximum ambient operation Standard ambient (8)	(°C)	46	46	46	46	46
Maximum ambient operation High ambient (8)	(°C)	Not available	Not available	Not available	Not available	Not available
System data						
Nb of refrigerant circuit	#	1	1	2	2	2
Minimum cooling load % (6)	%	30	30	15	15	15
Standard unit						
R134a refrigerant charge Circuit1 / Circuit 2	(kg)	79	93	68/66	78/86	93/86
Oil charge Circuit1 / Circuit 2	(l)	11.5	13.5	11.5/11.5	11.5/13.5	13.5/13.5
Brine application unit						
R134a refrigerant charge Circuit1 / Circuit 2	(kg)	91	107	78/76	90/99	107/99
Oil charge Circuit1 / Circuit 2	(l)	13.0	15.0	13/13	13/15	15/15
Type		OIL00317 or OIL00311				

(1) Indicative performance at Evaporator water temperature: 12°C / 7°C- Condenser air temperature 35°C- for detailed performances consult Order Write Up.

(2) Under 400V/3/50Hz.

(3) Rated Condition without Pump Package.

(4) Percent minimum load may be adjusted around 15%-20% according to operating conditions by local sales office.

(5) Electrical & system data are indicative and subject to change without notice. Please refer to unit nameplate data.

(6) Not applicable for Glycol application- see tables with Minimum Flow with Glycol.

(7) Max speed- range is 60% to 100% of max speed.

(8) Refrigerant charge may vary according to option- for instance +20% for process (digit 19 = p). For real value refer to unit nameplate.

(9) Data containing information on two circuits shown as follows: ckt1/ckt2.

Table 27 – General Data RTAF 100-330 Extra Seasonal Short –Standard Noise & Low Noise – R134a

		RTAF 100	RTAF 165	RTAF 200	RTAF 265	RTAF 330
		XSS-SN-LN	XSS-SN-LN	XSS-SN-LN	XSS-SN-LN	XSS-SN-LN
Cooling Capacity (1)	(kW)	358	576	700	934	1176
Unit electrical data (2) (3) (4)						
Maximum power input in cooling	(kW)	134	229	264	358	456
Unit rated amps (Max compr+Fan+Control)	(A)	212	358	414	560	713
Unit start up amps (Starting Amps of the larges compr+RLA of 2nd compr+RLA of all fans+control)	(A)	212	358	414	560	713
Displacement Power Factor (DPF)		0.94	0.95	0.95	0.95	0.95
Max power cable cross section	(mm ²)	2*300	2*300	2*300	4*185	4*185
Disconnect switch size	(A)	630	630	630	1250	1250
Compressor						
Quantity	#	1	1	2	2	2
Type		Screw	Screw	Screw	Screw	Screw
Model		100 / 0	165 / 0	100 / 100	100 / 165	165 / 165
Max Compressor power input circuit1/circuit 2	(A)	122 / 0	213 / 0	122 / 122	122 / 213	213 / 213
Max Amps Circuit1 / Circuit 2	(A)	186 / 0	323 / 0	186 / 186	186 / 323	323 / 323
Startup Amps Circuit 1/Circuit 2		186 / 0	323 / 0	186 / 186	186 / 323	323 / 323
Motor RPM (variable speed)	(rpm)	5800	5250	5800-5800	5800-5250	5250-5250
Oil sump heater Circuit1 / Circuit 2	(W)	340	340	550	550	550
Evaporator						
Quantity	#	1	1	1	1	1
Type		Flooded Shell and Tube Heat Exchanger				
Evaporator model		166D	166C	200A	330B	330B
Evaporator Water Content volume	(l)	57	66	105	110	110
Antifreeze heater	(W)	1640	1640	2040	2040	2040
Evaporator						
Evap. Water Flow rate - Minimum	(l/s)	8.7	10.7	15.3	20.1	20.1
Evap. Water Flow rate - Maximum (6)	(l/s)	32.1	39.5	56.6	74.5	74.5
Nominal water connection size (Grooved coupling)	(in) - (mm)	5" - 125	5" - 125	6" - 150	6" - 150	6" - 150
Evaporator with turbulators						
Evap. Water Flow rate - Minimum	(l/s)	7.2	8.9	12.7	16.7	16.7
Evap. Water Flow rate - Maximum	(l/s)	28.8	35.4	50.8	66.9	66.9
Nominal water connection size (Grooved coupling)	(in) - (mm)	5" - 125	5" - 125	6" - 150	6" - 150	6" - 150
Hydraulic Module Components						
Standard head pressure pump option (Twin pump)						
Available Head Pressure	(kPa)	143	143	143	118	140
Max Motor Power input	(kW)	5.5	11	11	18.5	22
Max Amps	(A)	11	20.8	20.8	34.5	39.7
High head pressure pump option (Twin Pump)						
Available Head Pressure	(kPa)	183	205	254	220	174
Max Motor Power input	(kW)	11	15	18.5	0	0
Max Amps	(A)	20.8	28	34.5	0	0
Expansion Tank Volume	(l)	80	80	80	80	80
Max User water loop Volume for factory mounted expansion tank (1)	(l)	6000	6000	6000	6000	6000
Max. Water-side Operating Pressure without pump package	(kPa)	1000	1000	1000	1000	1000
Max. Water-side Operating Pressure with pump package	(kPa)	450	450	450	450	450
Antifreeze Heater with pump package	(kPa)	2400	2400	2400	2400	2400
Condenser						
Type		Full aluminum Micro channel heat exchanger				
Quantity	#	6	8	5/5	5/7	8/8
Face area per coil	(m ²)	2.4	2.4	2.4	2.4	2.4
Condenser Fan (nominal conditions)						
Quantity	#	6	8	5/5	5/7	8/8
Diameter	(mm)	800	800	800	800	800
Standard fan						
Fan / motor Type		Propeller fan / Fixed speed - AC motor				
Airflow per Fan	(m ³ /h)	20000	20000	20000	20000	20000
Power per Motor	(kW)	1.4	1.4	1.4	1.4	1.4
Rated Amps per Motor	(A)	3.4	3.4	3.4	3.4	3.4
Rated motor RPM	(rpm)	932	932	932	932	932

Table 27 – General Data RTAF 100-330 Extra Seasonal Short –Standard Noise & Low Noise – R134a (continued)

		RTAF 100	RTAF 165	RTAF 200	RTAF 265	RTAF 330
		XSS-SN-LN	XSS-SN-LN	XSS-SN-LN	XSS-SN-LN	XSS-SN-LN
Dimensions						
Unit Length	(mm)	4520	4520	5645	7254	9396
Unit Width	(mm)	2220	2220	2220	2220	2220
Unit Height	(mm)	2526	2526	2526	2526	2526
Weights						
Shipping Weight(5)	(kg)	2850	3415	4635	5810	6750
Operating Weight(5)	(kg)	2920	3500	4765	5960	6915
Operating Limits						
Minimum Starting/Operating Ambient (7)						
Standard ambient unit	(°C)	-10	-10	-10	-10	-10
Low Ambient (Option)	(°C)	-20	-20	-20	-20	-20
Maximum ambient operation Standard ambient (8)	(°C)	46	46	46	46	46
Maximum ambient operation High ambient (8)	(°C)	Not available	Not available	Not available	Not available	Not available
System data						
Nb of refrigerant circuit	#	1	1	2	2	2
Minimum cooling load % (6)	%	30	30	15	15	15
Standard unit						
R134a refrigerant charge Circuit1 / Circuit 2	(kg)	66	80	61/60	69/78	81/80
Oil charge Circuit1 / Circuit 2	(l)	11.5	13.5	11.5/11.5	11.5/13.5	13.5/13.5
Brine application unit						
R134a refrigerant charge Circuit1 / Circuit 2	(kg)	75	92	70/69	79/90	93/92
Oil charge Circuit1 / Circuit 2	(l)	13.0	15.0	13/13	13/15	15/15
Type		OIL00317 or OIL00311				

(1) Indicative performance at Evaporator water temperature: 12°C / 7°C- Condenser air temperature 35°C- for detailed performances consult Order Write Up.

(2) Under 400V/3/50Hz.

(3) Rated Condition without Pump Package.

(4) Percent minimum load may be adjusted around 15%-20% according to operating conditions by local sales office.

(5) Electrical & system data are indicative and subject to change without notice. Please refer to unit nameplate data.

(6) Not applicable for Glycol application- see tables with Minimum Flow with Glycol.

(7) Max speed- range is 60% to 100% of max speed.

(8) Refrigerant charge may vary according to option- for instance +20% for process (digit 19 = p). For real value refer to unit nameplate.

(9) Data containing information on two circuits shown as follows: ckt1/ckt2.

Table 28 – General Data RTAF 100-330 Extra Seasonal Short –Low Ambient Standard Noise & Low Noise – R134a

		RTAF 100	RTAF 165	RTAF 200	RTAF 265	RTAF 330
		XSS-LA-SN-LN	XSS-LA-SN-LN	XSS-LA-SN-LN	XSS-LA-SN-LN	XSS-LA-SN-LN
Cooling Capacity (1)	(kW)	358	563	701	935	1177
Unit electrical data (2) (3) (4)						
Maximum power input in cooling	(kW)	135	229	265	360	458
Unit rated amps (Max compr+Fan+Control)	(A)	206	350	404	548	697
Unit start up amps (Starting Amps of the larges compr+RLA of 2nd compr+RLA of all fans+control)	(A)	206	350	404	548	697
Displacement Power Factor (DPF)		0.94	0.95	0.95	0.95	0.95
Max power cable cross section	(mm ²)	2*300	2*300	2*300	4*185	4*185
Disconnect switch size	(A)	630	630	630	1250	1250
Compressor						
Quantity	#	1	1	2	2	2
Type		Screw	Screw	Screw	Screw	Screw
Model		100 / 0	165 / 0	100 / 100	100 / 165	165 / 165
Max Compressor power input circuit1/circuit 2	(A)	122 / 0	213 / 0	122 / 122	122 / 213	213 / 213
Max Amps Circuit1 / Circuit 2	(A)	186 / 0	323 / 0	186 / 186	186 / 323	323 / 323
Startup Amps Circuit 1/Circuit 2		186 / 0	323 / 0	186 / 186	186 / 323	323 / 323
Motor RPM (variable speed)	(rpm)	5800	5250	5800-5800	5800-5250	5250-5250
Oil sump heater Circuit1 / Circuit 2	(W)	340	340	550	550	550
Evaporator						
Quantity	#	1	1	1	1	1
Type		Flooded Shell and Tube Heat Exchanger				
Evaporator model		166D	166C	200A	330B	330B
Evaporator Water Content volume	(l)	57	66	105	110	110
Antifreeze heater	(W)	1640	1640	2040	2040	2040
Evaporator						
Evap. Water Flow rate - Minimum	(l/s)	8.7	10.7	15.3	20.1	20.1
Evap. Water Flow rate - Maximum (6)	(l/s)	32.1	39.5	56.6	74.5	74.5
Nominal water connection size (Grooved coupling)	(in) - (mm)	5" - 125	5" - 125	6" - 150	6" - 150	6" - 150
Evaporator with turbulators						
Evap. Water Flow rate - Minimum	(l/s)	7.2	8.9	12.7	16.7	16.7
Evap. Water Flow rate - Maximum	(l/s)	28.8	35.4	50.8	66.9	66.9
Nominal water connection size (Grooved coupling)	(in) - (mm)	5" - 125	5" - 125	6" - 150	6" - 150	6" - 150
Hydraulic Module Components						
Standard head pressure pump option (Twin pump)						
Available Head Pressure	(kPa)	143	143	143	118	140
Max Motor Power input	(kW)	5.5	11	11	18.5	22
Max Amps	(A)	11	20.8	20.8	34.5	39.7
High head pressure pump option (Twin Pump)						
Available Head Pressure	(kPa)	183	205	254	220	174
Max Motor Power input	(kW)	11	15	18.5	0	0
Max Amps	(A)	20.8	28	34.5	0	0
Expansion Tank Volume	(l)	80	80	80	80	80
Max User water loop Volume for factory mounted expansion tank (1)	(l)	6000	6000	6000	6000	6000
Max. Water-side Operating Pressure without pump package	(kPa)	1000	1000	1000	1000	1000
Max. Water-side Operating Pressure with pump package	(kPa)	450	450	450	450	450
Antifreeze Heater with pump package	(kPa)	2400	2400	2400	2400	2400
Condenser						
Type		Full aluminum Micro channel heat exchanger				
Quantity	#	6	8	5/5	5/7	8/8
Face area per coil	(m ²)	2.4	2.4	2.4	2.4	2.4
Condenser Fan (nominal conditions)						
Quantity	#	6	8	5/5	5/7	8/8
Diameter	(mm)	800	800	800	800	800
Standard fan						
Fan / motor Type		Propeller fan / Variable speed - EC motor				
Airflow per Fan	(m ³ /h)	20000	20000	20000	20000	20000
Power per Motor	(kW)	1.3	1.3	1.3	1.3	1.3
Rated Amps per Motor	(A)	2.3	2.3	2.3	2.3	2.3
Rated motor RPM	(rpm)	860	860	860	860	860

Table 28 – General Data RTAF 100-330 Extra Seasonal Short –Low Ambient Standard Noise & Low Noise – R134a (continued)

		RTAF 100	RTAF 165	RTAF 200	RTAF 265	RTAF 330
		XSS-LA-SN-LN	XSS-LA-SN-LN	XSS-LA-SN-LN	XSS-LA-SN-LN	XSS-LA-SN-LN
Dimensions						
Unit Length	(mm)	4520	4520	5645	7254	9396
Unit Width	(mm)	2220	2220	2220	2220	2220
Unit Height	(mm)	2526	2526	2526	2526	2526
Weights						
Shipping Weight(5)	(kg)	2850	3415	4635	5810	6750
Operating Weight(5)	(kg)	2920	3500	4765	5960	6915
Operating Limits						
Minimum Starting/Operating Ambient (7)						
Standard ambient unit	(°C)	-10	-10	-10	-10	-10
Low Ambient (Option)	(°C)	-20	-20	-20	-20	-20
Maximum ambient operation Standard ambient (8)	(°C)	46	46	46	46	46
Maximum ambient operation High ambient (8)	(°C)	Not available	Not available	Not available	Not available	Not available
System data						
Nb of refrigerant circuit	#	1	1	2	2	2
Minimum cooling load % (6)	%	30	30	15	15	15
Standard unit						
R134a refrigerant charge Circuit1 / Circuit 2	(kg)	66	80	61/60	69/78	81/80
Oil charge Circuit1 / Circuit 2	(l)	11.5	13.5	11.5/11.5	11.5/13.5	13.5/13.5
Brine application unit						
R134a refrigerant charge Circuit1 / Circuit 2	(kg)	75	92	70/69	79/90	93/92
Oil charge Circuit1 / Circuit 2	(l)	13.0	15.0	13/13	13/15	15/15
Type		OIL00317 or OIL00311				

(1) Indicative performance at Evaporator water temperature: 12°C / 7°C- Condenser air temperature 35°C- for detailed performances consult Order Write Up.

(2) Under 400V/3/50Hz.

(3) Rated Condition without Pump Package.

(4) Percent minimum load may be adjusted around 15%-20% according to operating conditions by local sales office.

(5) Electrical & system data are indicative and subject to change without notice. Please refer to unit nameplate data.

(6) Not applicable for Glycol application- see tables with Minimum Flow with Glycol.

(7) Max speed- range is 60% to 100% of max speed.

(8) Refrigerant charge may vary according to option- for instance +20% for process (digit 19 = p). For real value refer to unit nameplate.

(9) Data containing information on two circuits shown as follows: ckt1/ckt2.

Table 29 – General Data RTAF 100-330 Extra Seasonal Short –EC Extra Low Noise – R134a

		RTAF 100	RTAF 165	RTAF 200	RTAF 265	RTAF 330
		XSS-EC XLN	XSS-EC XLN	XSS-EC XLN	XSS-EC XLN	XSS-EC XLN
Cooling Capacity (1)	(kW)	358	563	701	935	1177
Unit electrical data (2) (3) (4)						
Maximum power input in cooling	(kW)	135	229	265	360	458
Unit rated amps (Max compr+Fan+Control)	(A)	206	350	404	548	697
Unit start up amps (Starting Amps of the larges compr+RLA of 2nd compr+RLA of all fans+control)	(A)	206	350	404	548	697
Displacement Power Factor (DPF)		0.94	0.95	0.95	0.95	0.95
Max power cable cross section	(mm ²)	2*300	2*300	2*300	4*185	4*185
Disconnect switch size	(A)	630	630	630	1250	1250
Compressor						
Quantity	#	1	1	2	2	2
Type		Screw	Screw	Screw	Screw	Screw
Model		100 / 0	165 / 0	100 / 100	100 / 165	165 / 165
Max Compressor power input circuit1/circuit 2	(A)	122 / 0	213 / 0	122 / 122	122 / 213	213 / 213
Max Amps Circuit1 / Circuit 2	(A)	186 / 0	323 / 0	186 / 186	186 / 323	323 / 323
Startup Amps Circuit 1/Circuit 2		186 / 0	323 / 0	186 / 186	186 / 323	323 / 323
Motor RPM (variable speed)	(rpm)	5800	5250	5800-5800	5800-5250	5250-5250
Oil sump heater Circuit1 / Circuit 2	(W)	340	340	550	550	550
Evaporator						
Quantity	#	1	1	1	1	1
Type		Flooded Shell and Tube Heat Exchanger				
Evaporator model		166D	166C	200A	330B	330B
Evaporator Water Content volume	(l)	57	66	105	110	110
Antifreeze heater	(W)	1640	1640	2040	2040	2040
Evaporator						
Evap. Water Flow rate - Minimum	(l/s)	8.7	10.7	15.3	20.1	20.1
Evap. Water Flow rate - Maximum (6)	(l/s)	32.1	39.5	56.6	74.5	74.5
Nominal water connection size (Grooved coupling)	(in) - (mm)	5" - 125	5" - 125	6" - 150	6" - 150	6" - 150
Evaporator with turbulators						
Evap. Water Flow rate - Minimum	(l/s)	7.2	8.9	12.7	16.7	16.7
Evap. Water Flow rate - Maximum	(l/s)	28.8	35.4	50.8	66.9	66.9
Nominal water connection size (Grooved coupling)	(in) - (mm)	5" - 125	5" - 125	6" - 150	6" - 150	6" - 150
Hydraulic Module Components						
Standard head pressure pump option (Twin pump)						
Available Head Pressure	(kPa)	143	143	143	118	140
Max Motor Power input	(kW)	5.5	11	11	18.5	22
Max Amps	(A)	11	20.8	20.8	34.5	39.7
High head pressure pump option (Twin Pump)						
Available Head Pressure	(kPa)	183	205	254	220	174
Max Motor Power input	(kW)	11	15	18.5	0	0
Max Amps	(A)	20.8	28	34.5	0	0
Expansion Tank Volume	(l)	80	80	80	80	80
Max User water loop Volume for factory mounted expansion tank (1)	(l)	6000	6000	6000	6000	6000
Max. Water-side Operating Pressure without pump package	(kPa)	1000	1000	1000	1000	1000
Max. Water-side Operating Pressure with pump package	(kPa)	450	450	450	450	450
Antifreeze Heater with pump packagee	(kPa)	2400	2400	2400	2400	2400
Condenser						
Type		Full aluminum Micro channel heat exchanger				
Quantity	#	6	8	5/5	5/7	8/8
Face area per coil	(m ²)	2.4	2.4	2.4	2.4	2.4
Condenser Fan (nominal conditions)						
Quantity	#	6	8	5/5	5/7	8/8
Diameter	(mm)	800	800	800	800	800
Standard fan						
Fan / motor Type		Propeller fan / Variable speed - EC motor				
Airflow per Fan	(m ³ /h)	20000	20000	20000	20000	20000
Power per Motor	(kW)	1.1	1.1	1.1	1.1	1.1
Rated Amps per Motor	(A)	1.8	1.8	1.8	1.8	1.8
Rated motor RPM	(rpm)	860	860	860	860	860

Table 29 – General Data RTAF 100-330 Extra Seasonal Short –EC Extra Low Noise – R134a (continued)

		RTAF 100	RTAF 165	RTAF 200	RTAF 265	RTAF 330
		XSS-EC XLN	XSS-EC XLN	XSS-EC XLN	XSS-EC XLN	XSS-EC XLN
Dimensions						
Unit Length	(mm)	4520	4520	5645	7254	9396
Unit Width	(mm)	2220	2220	2220	2220	2220
Unit Height	(mm)	2526	2526	2526	2526	2526
Weights						
Shipping Weight(5)	(kg)	2900	3465	4735	5910	6850
Operating Weight(5)	(kg)	2970	3550	4865	6060	7015
Operating Limits						
Minimum Starting/Operating Ambient (7)						
Standard ambient unit	(°C)	-10	-10	-10	-10	-10
Low Ambient (Option)	(°C)	-20	-20	-20	-20	-20
Maximum ambient operation Standard ambient (8)	(°C)	46	46	46	46	46
Maximum ambient operation High ambient (8)	(°C)	Not available	Not available	Not available	Not available	Not available
System data						
Nb of refrigerant circuit	#	1	1	2	2	2
Minimum cooling load % (6)	%	30	30	15	15	15
Standard unit						
R134a refrigerant charge Circuit1 / Circuit 2	(kg)	66	80	61/60	69/78	81/80
Oil charge Circuit1 / Circuit 2	(l)	11.5	13.5	11.5/11.5	11.5/13.5	13.5/13.5
Brine application unit						
R134a refrigerant charge Circuit1 / Circuit 2	(kg)	75	92	70/69	79/90	93/92
Oil charge Circuit1 / Circuit 2	(l)	13.0	15.0	13/13	13/15	15/15
Type		OIL00317 or OIL00311				

(1) Indicative performance at Evaporator water temperature: 12°C / 7°C - Condenser air temperature 35°C - for detailed performances consult Order Write Up.

(2) Under 400V/3/50Hz.

(3) Rated Condition without Pump Package.

(4) Percent minimum load may be adjusted around 15%-20% according to operating conditions by local sales office.

(5) Electrical & system data are indicative and subject to change without notice. Please refer to unit nameplate data.

(6) Not applicable for Glycol application- see tables with Minimum Flow with Glycol.

(7) Max speed- range is 60% to 100% of max speed.

(8) Refrigerant charge may vary according to option- for instance +20% for process (digit 19 = p). For real value refer to unit nameplate.

(9) Data containing information on two circuits shown as follows: ckt1/ckt2.

Table 30 – General Data RTAF 100-330 Extra Seasonal Short –EC Whisper Low Noise – R134a

		RTAF 100	RTAF 165	RTAF 200	RTAF 265	RTAF 330
		XSS-EC WLN	XSS-EC WLN	XSS-EC WLN	XSS-EC WLN	XSS-EC WLN
Cooling Capacity (1)	(kW)	335	524	675	901	1064
Unit electrical data (2) (3) (4)						
Maximum power input in cooling	(kW)	135	229	265	360	458
Unit rated amps (Max compr+Fan+Control)	(A)	206	350	404	548	697
Unit start up amps (Starting Amps of the larges compr+RLA of 2nd compr+RLA of all fans+control)	(A)	206	350	404	548	697
Displacement Power Factor (DPF)		0.94	0.95	0.95	0.95	0.95
Max power cable cross section	(mm ²)	2*300	2*300	2*300	4*185	4*185
Disconnect switch size	(A)	630	630	630	1250	1250
Compressor						
Quantity	#	1	1	2	2	2
Type		Screw	Screw	Screw	Screw	Screw
Model		100 / 0	165 / 0	100 / 100	100 / 165	165 / 165
Max Compressor power input circuit1/circuit 2	(A)	122 / 0	213 / 0	122 / 122	122 / 213	213 / 213
Max Amps Circuit1 / Circuit 2	(A)	186 / 0	323 / 0	186 / 186	186 / 323	323 / 323
Startup Amps Circuit 1/Circuit 2		186 / 0	323 / 0	186 / 186	186 / 323	323 / 323
Motor RPM (variable speed)	(rpm)	5800	5250	5800-5800	5800-5250	5250-5250
Oil sump heater Circuit1 / Circuit 2	(W)	340	340	550	550	550
Evaporator						
Quantity	#	1	1	1	1	1
Type		Flooded Shell and Tube Heat Exchanger				
Evaporator model		166D	166C	200A	330B	330B
Evaporator Water Content volume	(l)	57	66	105	110	110
Antifreeze heater	(W)	1640	1640	2040	2040	2040
Evaporator						
Evap. Water Flow rate - Minimum	(l/s)	8.7	10.7	15.3	20.1	20.1
Evap. Water Flow rate - Maximum (6)	(l/s)	32.1	39.5	56.6	74.5	74.5
Nominal water connection size (Grooved coupling)	(in) - (mm)	5" - 125	5" - 125	6" - 150	6" - 150	6" - 150
Evaporator with turbulators						
Evap. Water Flow rate - Minimum	(l/s)	7.2	8.9	12.7	16.7	16.7
Evap. Water Flow rate - Maximum	(l/s)	28.8	35.4	50.8	66.9	66.9
Nominal water connection size (Grooved coupling)	(in) - (mm)	5" - 125	5" - 125	6" - 150	6" - 150	6" - 150
Hydraulic Module Components						
Standard head pressure pump option (Twin pump)						
Available Head Pressure	(kPa)	143	143	143	118	140
Max Motor Power input	(kW)	5.5	11	11	18.5	22
Max Amps	(A)	11	20.8	20.8	34.5	39.7
High head pressure pump option (Twin Pump)						
Available Head Pressure	(kPa)	183	205	254	220	174
Max Motor Power input	(kW)	11	15	18.5	0	0
Max Amps	(A)	20.8	28	34.5	0	0
Expansion Tank Volume	(l)	80	80	80	80	80
Max User water loop Volume for factory mounted expansion tank (1)	(l)	6000	6000	6000	6000	6000
Max. Water-side Operating Pressure without pump package	(kPa)	1000	1000	1000	1000	1000
Max. Water-side Operating Pressure with pump package	(kPa)	450	450	450	450	450
Antifreeze Heater with pump packagee	(kPa)	2400	2400	2400	2400	2400
Condenser						
Type		Full aluminum Micro channel heat exchanger				
Quantity	#	6	8	5/5	5/7	8/8
Face area per coil	(m ²)	2.4	2.4	2.4	2.4	2.4
Condenser Fan (nominal conditions)						
Quantity	#	6	8	5/5	5/7	8/8
Diameter	(mm)	800	800	800	800	800
Standard fan						
Fan / motor Type		Propeller fan / Variable speed - EC motor				
Airflow per Fan	(m ³ /h)	20000	20000	20000	20000	20000
Power per Motor	(kW)	1.1	1.1	1.1	1.1	1.1
Rated Amps per Motor	(A)	1.8	1.8	1.8	1.8	1.8
Rated motor RPM	(rpm)	860	860	860	860	860

Table 30 – General Data RTAF 100-330 Extra Seasonal Short –EC Whisper Low Noise – R134a (continued)

		RTAF 100	RTAF 165	RTAF 200	RTAF 265	RTAF 330
		XSS-EC WLN	XSS-EC WLN	XSS-EC WLN	XSS-EC WLN	XSS-EC WLN
Dimensions						
Unit Length	(mm)	4520	4520	5645	7254	9396
Unit Width	(mm)	2220	2220	2220	2220	2220
Unit Height	(mm)	2526	2526	2526	2526	2526
Weights						
Shipping Weight(5)	(kg)	3020	3585	4975	6150	7090
Operating Weight(5)	(kg)	3090	3670	5105	6300	7255
Operating Limits						
Minimum Starting/Operating Ambient (7)						
Standard ambient unit	(°C)	-10	-10	-10	-10	-10
Low Ambient (Option)	(°C)	-20	-20	-20	-20	-20
Maximum ambient operation Standard ambient (8)	(°C)	46	46	46	46	46
Maximum ambient operation High ambient (8)	(°C)	Not available	Not available	Not available	Not available	Not available
System data						
Nb of refrigerant circuit	#	1	1	2	2	2
Minimum cooling load % (6)	%	30	30	15	15	15
Standard unit						
R134a refrigerant charge Circuit1 / Circuit 2	(kg)	66	80	61/60	69/78	81/80
Oil charge Circuit1 / Circuit 2	(l)	11.5	13.5	11.5/11.5	11.5/13.5	13.5/13.5
Brine application unit						
R134a refrigerant charge Circuit1 / Circuit 2	(kg)	75	92	70/69	79/90	93/92
Oil charge Circuit1 / Circuit 2	(l)	13.0	15.0	13/13	13/15	15/15
Type		OIL00317 or OIL00311				

(1) Indicative performance at Evaporator water temperature: 12°C / 7°C- Condenser air temperature 35°C- for detailed performances consult Order Write Up.

(2) Under 400V/3/50Hz.

(3) Rated Condition without Pump Package.

(4) Percent minimum load may be adjusted around 15%-20% according to operating conditions by local sales office.

(5) Electrical & system data are indicative and subject to change without notice. Please refer to unit nameplate data.

(6) Not applicable for Glycol application- see tables with Minimum Flow with Glycol.

(7) Max speed- range is 60% to 100% of max speed.

(8) Refrigerant charge may vary according to option- for instance +20% for process (digit 19 = p). For real value refer to unit nameplate.

(9) Data containing information on two circuits shown as follows: ckt1/ckt2.

Table 31 – General Data RTAF 100-330 Extra Seasonal Short –AC Extra Low Noise – R134a

		RTAF 100	RTAF 165	RTAF 200	RTAF 265	RTAF 330
		XSS-AC XLN	XSS-AC XLN	XSS-AC XLN	XSS-AC XLN	XSS-AC XLN
Cooling Capacity (1)	(kW)	355	570	692	921	1162
Unit electrical data (2) (3) (4)						
Maximum power input in cooling	(kW)	132	225	260	353	450
Unit rated amps (Max compr+Fan+Control)	(A)	206	349	403	547	696
Unit start up amps (Starting Amps of the larges compr+RLA of 2nd compr+RLA of all fans+control)	(A)	206	349	403	547	696
Displacement Power Factor (DPF)		0.93	0.93	0.93	0.93	0.93
Max power cable cross section	(mm ²)	2*300	2*300	2*300	4*185	4*185
Disconnect switch size	(A)	630	630	630	1250	1250
Compressor						
Quantity	#	1	1	2	2	2
Type		Screw	Screw	Screw	Screw	Screw
Model		100 / 0	165 / 0	100 / 100	100 / 165	165 / 165
Max Compressor power input circuit1/circuit 2	(A)	122 / 0	213 / 0	122 / 122	122 / 213	213 / 213
Max Amps Circuit1 / Circuit 2	(A)	186 / 0	323 / 0	186 / 186	186 / 323	323 / 323
Startup Amps Circuit 1/Circuit 2		186 / 0	323 / 0	186 / 186	186 / 323	323 / 323
Motor RPM (variable speed)	(rpm)	5800	5250	5800-5800	5800-5250	5250-5250
Oil sump heater Circuit1 / Circuit 2	(W)	340	340	550	550	550
Evaporator						
Quantity	#	1	1	1	1	1
Type		Flooded Shell and Tube Heat Exchanger				
Evaporator model		166D	166C	200A	330B	330B
Evaporator Water Content volume	(l)	57	66	105	110	110
Antifreeze heater	(W)	1640	1640	2040	2040	2040
Evaporator						
Evap. Water Flow rate - Minimum	(l/s)	8.7	10.7	15.3	20.1	20.1
Evap. Water Flow rate - Maximum (6)	(l/s)	32.1	39.5	56.6	74.5	74.5
Nominal water connection size (Grooved coupling)	(in) - (mm)	5" - 125	5" - 125	6" - 150	6" - 150	6" - 150
Evaporator with turbulators						
Evap. Water Flow rate - Minimum	(l/s)	7.2	8.9	12.7	16.7	16.7
Evap. Water Flow rate - Maximum	(l/s)	28.8	35.4	50.8	66.9	66.9
Nominal water connection size (Grooved coupling)	(in) - (mm)	5" - 125	5" - 125	6" - 150	6" - 150	6" - 150
Hydraulic Module Components						
Standard head pressure pump option (Twin pump)						
Available Head Pressuret	(kPa)	143	143	143	118	140
Max Motor Power input	(kW)	5.5	11	11	18.5	22
Max Amps	(A)	11	20.8	20.8	34.5	39.7
High head pressure pump option (Twin Pump)						
Available Head Pressure	(kPa)	183	205	254	220	174
Max Motor Power input	(kW)	11	15	18.5	0	0
Max Amps	(A)	20.8	28	34.5	0	0
Expansion Tank Volume	(l)	80	80	80	80	80
Max User water loop Volume for factory mounted expansion tank (1)	(l)	6000	6000	6000	6000	6000
Max. Water-side Operating Pressure without pump package	(kPa)	1000	1000	1000	1000	1000
Max. Water-side Operating Pressure with pump package	(kPa)	450	450	450	450	450
Antifreeze Heater with pump packagee	(kPa)	2400	2400	2400	2400	2400
Condenser						
Type		Full aluminum Micro channel heat exchanger				
Quantity	#	6	8	5/5	5/7	8/8
Face area per coil	(m ²)	2.4	2.4	2.4	2.4	2.4
Condenser Fan (nominal conditions)						
Quantity	#	6	8	5/5	5/7	8/8
Diameter	(mm)	800	800	800	800	800
Standard fan						
Fan / motor Type		Propeller fan / Variable speed - EC motor				
Airflow per Fan	(m ³ /h)	18000	18000	18000	18000	18000
Power per Motor	(kW)	1.2	1.2	1.2	1.2	1.2
Rated Amps per Motor	(A)	2.9	2.9	2.9	2.9	2.9
Rated Motor RPM	(rpm)	900	900	900	900	900

Table 31 – General Data RTAF 100-330 Extra Seasonal Short –AC Extra Low Noise – R134a (continued)

		RTAF 100	RTAF 165	RTAF 200	RTAF 265	RTAF 330
		XSS-EC WLN	XSS-EC WLN	XSS-EC WLN	XSS-EC WLN	XSS-EC WLN
Dimensions						
Unit Length	(mm)	4520	4520	5645	7254	9396
Unit Width	(mm)	2220	2220	2220	2220	2220
Unit Height	(mm)	2526	2526	2526	2526	2526
Weights						
Shipping Weight(5)	(kg)	2900	3465	4735	5910	6850
Operating Weight(5)	(kg)	2970	3550	4865	6060	7015
Operating Limits						
Minimum Starting/Operating Ambient (7)						
Standard ambient unit	(°C)	-10	-10	-10	-10	-10
Low Ambient (Option)	(°C)	-20	-20	-20	-20	-20
Maximum ambient operation Standard ambient (8)	(°C)	46	46	46	46	46
Maximum ambient operation High ambient (8)	(°C)	Not available	Not available	Not available	Not available	Not available
System data						
Nb of refrigerant circuit	#	1	1	2	2	2
Minimum cooling load % (6)	%	30	30	15	15	15
Standard unit						
R134a refrigerant charge Circuit1 / Circuit 2	(kg)	66	80	61/60	69/78	81/80
Oil charge Circuit1 / Circuit 2	(l)	11.5	13.5	11.5/11.5	11.5/13.5	13.5/13.5
Brine application unit						
R134a refrigerant charge Circuit1 / Circuit 2	(kg)	75	92	70/69	79/90	93/92
Oil charge Circuit1 / Circuit 2	(l)	13.0	15.0	13/13	13/15	15/15
Type		OIL00317 or OIL00311				

(1) Indicative performance at Evaporator water temperature: 12°C / 7°C - Condenser air temperature 35°C - for detailed performances consult Order Write Up.

(2) Under 400V/3/50Hz.

(3) Rated Condition without Pump Package.

(4) Percent minimum load may be adjusted around 15%-20% according to operating conditions by local sales office.

(5) Electrical & system data are indicative and subject to change without notice. Please refer to unit nameplate data.

(6) Not applicable for Glycol application- see tables with Minimum Flow with Glycol.

(7) Max speed- range is 60% to 100% of max speed.

(8) Refrigerant charge may vary according to option- for instance +20% for process (digit 19 = p). For real value refer to unit nameplate.

(9) Data containing information on two circuits shown as follows: ckt1/ckt2.

Table 32 – General Data RTAF 100-330 Extra Seasonal Short –AC Whisper Low Noise – R134a

		RTAF 100	RTAF 165	RTAF 200	RTAF 265	RTAF 330
		XSS-AC WLN	XSS-AC WLN	XSS-AC WLN	XSS-AC WLN	XSS-AC WLN
Cooling Capacity (1)	(kW)	339	518	667	888	1075
Unit electrical data (2) (3) (4)						
Maximum power input in cooling	(kW)	132	225	260	353	450
Unit rated amps (Max compr+Fan+Control)	(A)	206	349	403	547	696
Unit start up amps (Starting Amps of the larges compr+RLA of 2nd compr+RLA of all fans+control)	(A)	206	349	403	547	696
Displacement Power Factor (DPF)		0.93	0.93	0.93	0.93	0.93
Max power cable cross section	(mm ²)	2*300	2*300	2*300	4*185	4*185
Disconnect switch size	(A)	630	630	630	1250	1250
Compressor						
Quantity	#	1	1	2	2	2
Type		Screw	Screw	Screw	Screw	Screw
Model		100 / 0	165 / 0	100 / 100	100 / 165	165 / 165
Max Compressor power input circuit1/circuit 2	(A)	122 / 0	213 / 0	122 / 122	122 / 213	213 / 213
Max Amps Circuit1 / Circuit 2	(A)	186 / 0	323 / 0	186 / 186	186 / 323	323 / 323
Startup Amps Circuit 1/Circuit 2		186 / 0	323 / 0	186 / 186	186 / 323	323 / 323
Motor RPM (variable speed)	(rpm)	5800	5250	5800-5800	5800-5250	5250-5250
Oil sump heater Circuit1 / Circuit 2	(W)	340	340	550	550	550
Evaporator						
Quantity	#	1	1	1	1	1
Type		Flooded Shell and Tube Heat Exchanger				
Evaporator model		166D	166C	200A	330B	330B
Evaporator Water Content volume	(l)	57	66	105	110	110
Antifreeze heater	(W)	1640	1640	2040	2040	2040
Evaporator						
Evap. Water Flow rate - Minimum	(l/s)	8.7	10.7	15.3	20.1	20.1
Evap. Water Flow rate - Maximum (6)	(l/s)	32.1	39.5	56.6	74.5	74.5
Nominal water connection size (Grooved coupling)	(in) - (mm)	5" - 125	5" - 125	6" - 150	6" - 150	6" - 150
Evaporator with turbulators						
Evap. Water Flow rate - Minimum	(l/s)	7.2	8.9	12.7	16.7	16.7
Evap. Water Flow rate - Maximum	(l/s)	28.8	35.4	50.8	66.9	66.9
Nominal water connection size (Grooved coupling)	(in) - (mm)	5" - 125	5" - 125	6" - 150	6" - 150	6" - 150
Hydraulic Module Components						
Standard head pressure pump option (Twin pump)						
Available Head Pressure	(kPa)	143	143	143	118	140
Max Motor Power input	(kW)	5.5	11	11	18.5	22
Max Amps	(A)	11	20.8	20.8	34.5	39.7
High head pressure pump option (Twin Pump)						
Available Head Pressure	(kPa)	183	205	254	220	174
Max Motor Power input	(kW)	11	15	18.5	0	0
Max Amps	(A)	20.8	28	34.5	0	0
Expansion Tank Volume	(l)	80	80	80	80	80
Max User water loop Volume for factory mounted expansion tank (1)	(l)	6000	6000	6000	6000	6000
Max. Water-side Operating Pressure without pump package	(kPa)	1000	1000	1000	1000	1000
Max. Water-side Operating Pressure with pump package	(kPa)	450	450	450	450	450
Antifreeze Heater with pump packagee	(kPa)	2400	2400	2400	2400	2400
Condenser						
Type		Full aluminum Micro channel heat exchanger				
Quantity	#	6	8	5/5	5/7	8/8
Face area per coil	(m ²)	2.4	2.4	2.4	2.4	2.4
Condenser Fan (nominal conditions)						
Quantity	#	6	8	5/5	5/7	8/8
Diameter	(mm)	800	800	800	800	800
Standard fan						
Fan / motor Type		Propeller fan / Variable speed - EC motor				
Airflow per Fan	(m ³ /h)	18000	18000	18000	18000	18000
Power per Motor	(kW)	1.2	1.2	1.2	1.2	1.2
Rated Amps per Motor	(A)	2.9	2.9	2.9	2.9	2.9
Rated Motor RPM	(rpm)	900	900	900	900	900

Table 32 – General Data RTAF 100-330 Extra Seasonal Short –AC Whisper Low Noise – R134a (continued)

		RTAF 100	RTAF 165	RTAF 200	RTAF 265	RTAF 330
		XSS-AC WLN	XSS-AC WLN	XSS-AC WLN	XSS-AC WLN	XSS-AC WLN
Dimensions						
Unit Length	(mm)	4520	4520	5645	7254	9396
Unit Width	(mm)	2220	2220	2220	2220	2220
Unit Height	(mm)	2526	2526	2526	2526	2526
Weights						
Shipping Weight(5)	(kg)	3020	3585	4975	6150	7090
Operating Weight(5)	(kg)	3090	3670	5105	6300	7255
Operating Limits						
Minimum Starting/Operating Ambient (7)						
Standard ambient unit	(°C)	-10	-10	-10	-10	-10
Low Ambient (Option)	(°C)	-20	-20	-20	-20	-20
Maximum ambient operation Standard ambient (8)	(°C)	46	46	46	46	46
Maximum ambient operation High ambient (8)	(°C)	Not available	Not available	Not available	Not available	Not available
System data						
Nb of refrigerant circuit	#	1	1	2	2	2
Minimum cooling load % (6)	%	30	30	15	15	15
Standard unit						
R134a refrigerant charge Circuit1 / Circuit 2	(kg)	66	80	61/60	69/78	81/80
Oil charge Circuit1 / Circuit 2	(l)	11.5	13.5	11.5/11.5	11.5/13.5	13.5/13.5
Brine application unit						
R134a refrigerant charge Circuit1 / Circuit 2	(kg)	75	92	70/69	79/90	93/92
Oil charge Circuit1 / Circuit 2	(l)	13.0	15.0	13/13	13/15	15/15
Type		OIL00317 or OIL00311				

(1) Indicative performance at Evaporator water temperature: 12°C / 7°C- Condenser air temperature 35°C- for detailed performances consult Order Write Up.

(2) Under 400V/3/50Hz.

(3) Rated Condition without Pump Package.

(4) Percent minimum load may be adjusted around 15%-20% according to operating conditions by local sales office.

(5) Electrical & system data are indicative and subject to change without notice. Please refer to unit nameplate data.

(6) Not applicable for Glycol application- see tables with Minimum Flow with Glycol.

(7) Max speed- range is 60% to 100% of max speed.

(8) Refrigerant charge may vary according to option- for instance +20% for process (digit 19 = p). For real value refer to unit nameplate.

(9) Data containing information on two circuits shown as follows: ckt1/ckt2.

Installation Requirements

Installation Responsibilities

Generally contractor must do the following items when installing an RTAF unit:

1. Install the unit on a flat foundation strong enough to support unit loading and level (within 5 mm across the length and width of the unit).
2. Install the units as per instructions contained in this manual.
3. Where specified, provide and install valves in the water piping upstream and downstream of the evaporator water connections, to isolate the evaporator for maintenance, and to balance and trim the system.
4. Furnish and install a water flow prove device and/or auxiliary contacts to prove chiller water flow.
5. Furnish and install water pressure gauges in the inlet and outlet of the evaporator water box.
6. Supply and install an air vent cock to the top of the evaporator water box.
7. Furnish and install strainers ahead of all pumps and automatic modulating valves.
8. Provide and install field wiring according to schematics provided in the control panel.
9. Install heat tape and insulate the chilled water lines and any other portion of the system, as required, to prevent sweating under normal operating conditions or freezing during low ambient temperature conditions.
10. Ensure that the compressor and oil separator heaters have been operating for a minimum of 24 hours before starting. Failure to do so may result in equipment damage.
11. Start the unit under supervision of a qualified service technician.

Nameplates

The RTAF outdoor unit nameplates are applied to the exterior of the control panel. A compressor nameplate is located on each compressor.

Unit Nameplate

The unit nameplate provides the following information:

- Unit model and size description
- Unit serial number
- Identifies unit electrical requirements
- Lists correct operating charges of R-134a and refrigerant oil
- Lists unit test pressures

Compressor Nameplate

The compressor nameplate provides following information:

- Compressor model number.
- Compressor serial number.
- Compressor electrical characteristics.
- Utilization range
- Recommended refrigerant

Storage

Extended storage of the unit prior to the installation requires the following precautions:

1. Store the unit in a secured area, to avoid intentional damages.
2. Close the suction, discharge and liquid-line isolation valves.
3. At least every three months, connect a gauge and manually check the pressure in the refrigerant circuit. If the refrigerant pressure is below 13 Bar at 20°C (or 10 Bar at 10°C), call a qualified service organization and the appropriate Trane sales office.

Note: if the unit is stored before servicing near a construction site it is highly recommended to protect micro channel coils from any concrete and iron element. Failure to do so may considerably reduce reliability of the unit.

Lifting and Moving Instructions

A specific lifting method is recommended, which can be described as follow:

1. Lifting points are built into the unit, see lifting instruction label on the unit.
2. Slings and spreader bar must be provided by crane operator and attached on the lifting points.
3. Use the 4 or 8 rigging points (according to unit size) which are built into the unit.
4. The minimum lifting capacity of each sling as well as the spreader bar must be higher than the tabulated unit shipping weight.
5. **CAUTION!** Lift and handle with care. Avoid shocks while handling.



Installation Requirements

Dimension and Weights

Dimensions details, dimensions of hydraulic connections, electrical connections, isolator positioning, specific features for heat recovery and free cooling are included in submittals and diagrams provided in documentation package.

Center of Gravity

See instructions on lifting drawings available on request.

WARNING! Heavy Objects!

Ensure that all the lifting equipment used is properly rated for weight of the unit being lifted. Each of the cables (chains or slings), hooks, and shackles used to lift the unit must be capable of supporting the entire weight of unit. Lifting cables (chains or slings) may not be the same length. Adjust as necessary for even unit lift. Other lifting arrangements could cause equipment or property damage. Failure to follow instructions above or properly lift unit could result in unit dropping and possibly crushing operator/technician which could result in death or serious injury.

WARNING! Improper Unit Lift!

Test lift unit approximately 10 cm to verify proper center of gravity lift point. To avoid dropping of unit, reposition lifting point if unit is not level. Failure to properly lift unit could result in unit dropping and possibly crushing operator/technician which could result in death or serious injury and possible equipment or property- only damage.

Clearances

When installing the unit, provide enough space around the unit to allow the installation and maintenance personnel unrestricted access to all service points. Unobstructed flow of condenser air is essential to maintain chiller capacity and operating efficiency. When determining unit placement, give careful consideration to ensuring a sufficient air flow across the condenser coils heat-transfer surface.

Notes:

1. Area above unit required for operation, maintenance, panel access and airflow: **NO OBSTRUCTIONS ABOVE UNIT**
2. For installations with obstructions or multiple units, refer to Trane office for Close Spacing and Restricted Airflow advices.
3. Minimum clearance of 1990 mm on the side of the unit is required for coil replacement. If sufficient clearance is not available on the side of the unit, coil replacement should be performed through top of unit.
4. Enough clearance is required in front of the control panels. Must be measured from front of panel, not end of unit base.
5. Clearances should be sufficient for tube pull out of evaporator (2.5 m in the evaporator water box side of the unit for 2 compressors units and 4.5 m for 3 and 4 compressors units)
6. Refer to submittal drawings for complementary information.

Unit Isolation and Leveling

Provide a foundation with sufficient strength and mass to support the unit operating weight (that is, including completed piping, full operating charges of refrigerant and oil, and water). Refer to unit operating weights. The unit must be leveled within 5 mm over its length and width. Use shims as necessary to level the unit. For additional reduction of sound and vibration, install the optional elastomeric isolators.

Sound consideration

The most effective form of acoustical isolation is to locate the unit away from any sound sensitive area. Structurally transmitted sound can be reduced by elastomeric vibration eliminators. Spring isolators are not recommended. Consult an acoustical engineer in critical sound applications.

For maximum isolation effect, isolate water lines and electrical conduit. Rubber isolated piping hangers can be used to reduce the sound transmitted through water piping. To reduce sound transmitted through electrical conduit, use flexible electrical conduit.

EU and Local Regulations codes on sound emissions should always be considered. Since the environment in which a sound source is located affects the sound pressure, unit placement must be carefully evaluated.

Installation Requirements

Elastomeric Isolators Installation (Optional)

Isolators are ready to install. Mountings have to be placed on a rigid and level foundation. External equipment should not transmit additional vibration to the chiller. The position of elastomeric isolator and weight per point are given in the Neoprene isolators installation drawing which is supplied with the chiller. Wrong placement along the unit may result in excessive deflection.

1. Secure the isolators to the mounting surface using the mounting slots in the isolator's base plate. Do NOT fully tighten the isolators mounting bolts at this time. See the isolators submittals for isolators location, maximum weights, and isolators diagrams.
2. Align the mounting holes in the base of the unit with the threaded positioning pins on the top of the isolators.
3. Install the unit on the isolators and secure the isolators to the unit with a nut. The maximum isolators deflection should be 13 mm.
4. Level the unit carefully. Fully tighten the isolator mounting bolts.

Figure 1 – Elastomeric Isolator

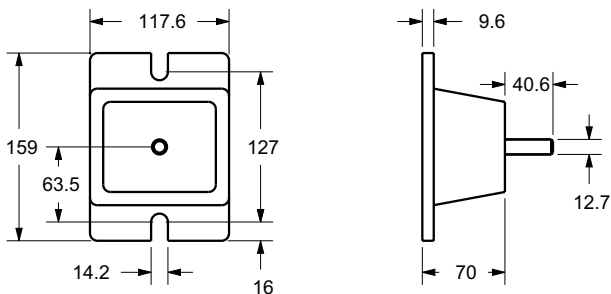

Isolator Pads Installation (Optional)

Isolators are ready to install. Mountings have to be placed on a rigid and level foundation. External equipment should not transmit additional vibration to the chiller. The position of pads isolator is given in the pad isolators installation or selection drawing which is supplied with the chiller.

Figure 2 – Isolator pads

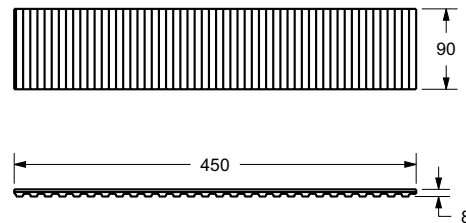



Chilled Water Piping Recommendations

Water Treatment

In the evaporator the following material are in contact with water:

- Water boxes are made of cast iron (GJL250 EN-code)
- Tube plates are made of steel (P265GH code)
- Tubes are made of copper
- Turbulators when present in evaporator tubes are made of phosphorous brass.

When the unit is supplied with hydraulic module, the following additional materials are in contact with water:

- Pump frame and connections are made of cast iron
- Water pipes are made of iron
- Pipe sealings are made of EPDM rubber (ethylene propylene diene monomer rubber)
- Pump sealings are made of silicon carbide
- Strainer is made of stainless steel

Notice!

Dirt, scale, products of corrosion, and other foreign material will adversely affect heat transfer between the water and system components. Foreign matter in the chilled-water system can also increase pressure drop and consequently, reduce water flow. Proper water treatment must be determined locally, depending on the type of system and local water characteristics.

Neither salt nor brackish water is recommended for use in Trane air-cooled chillers. Use of either will lead to an unpredictably shorter life cycle. Trane encourages the employment of a reputable water treatment specialist, familiar with local water conditions, to assist in this determination and in the establishment of a proper water treatment program.

CAUTION! If using an acidic commercial flushing solution, construct a temporary bypass around the unit to prevent damage to internal components of the evaporator. Trane assumes no responsibility for equipment failures which results from untreated or improperly treated water or saline or brackish water. If calcium chloride is used for water treatment, an applicable corrosion inhibitor must also be used. Failure to do so may result in damage to system components. Do not use untreated or improperly treated water. Equipment damage may occur.

Notice: Coil Damage!

Failure to follow instructions below could result in freecooling coil freeze. For units with free-cooling option, introduction of uninhibited water into the system is not recommended, as it could lead to internal corrosion and risk of coil freeze. To avoid free-cooling coil damage:

- If the building loop needs to be charged with water for testing purposes, isolate free-cooling coils by closing free-cooling service shut-off valve and modulating valve.
- Completely drain any water inadvertently introduced into the system, and replace with glycol fluid as required for the free-cooling system.
- If water was introduced for hydronic testing, and was not immediately replaced with glycol solution, a glycol (freeze inhibitor) solution must be introduced to the free-cooling system/coils for any long term storage.

Evaporator Piping

Evaporator water connections are grooved.

Thoroughly flush all water piping to the unit before making the final piping connections to the unit.

Components and layout will vary slightly, depending on the location of connections and the water sources (see figure Typical RTAF water piping figure).

An air vent is located on top of the evaporator at the chiller water outlet. Be sure to provide additional air vents at the highest points in the piping to remove air from the chilled water system. Install necessary pressure gauges to monitor the entering and leaving chilled water pressure.

Provide shut off valves in lines to the gauges to isolate them from the system when they are not in use. Use rubber vibration eliminators to prevent vibration transmission through the water lines.

If desired, install thermometers in the lines to monitor entering and leaving water line to control water flow balance. Install shutoff valves on both the entering and leaving water lines so that the evaporator can be isolated for service.

CAUTION! The chilled-water connections to the evaporator are to be "grooved pipe" type connections. Do not attempt to weld these connections, because the heat generated from welding can cause microscopic and macroscopic fractures on the cast iron water boxes that can lead to premature failure of the water box. An optional grooved pipe stub and coupling is available for welding on flanges.

To prevent damage to chilled-water components, do not allow evaporator pressure (maximum working pressure) to exceed 10 Bar. The maximum service pressure depends on free cooling type and potential pump package option. The value of max service pressure is indicated on unit nameplate.

A pipe strainer must be installed in the entering water line. Failure to do so can allow waterborne debris to enter the evaporator.

Evaporator Piping

Evaporator Piping Components

Piping components include all devices and controls used to provide proper water system operation and unit operating safety. A typical RTAF evaporator piping is shown below.

Figure 3 – Typical RTAF evaporator water piping

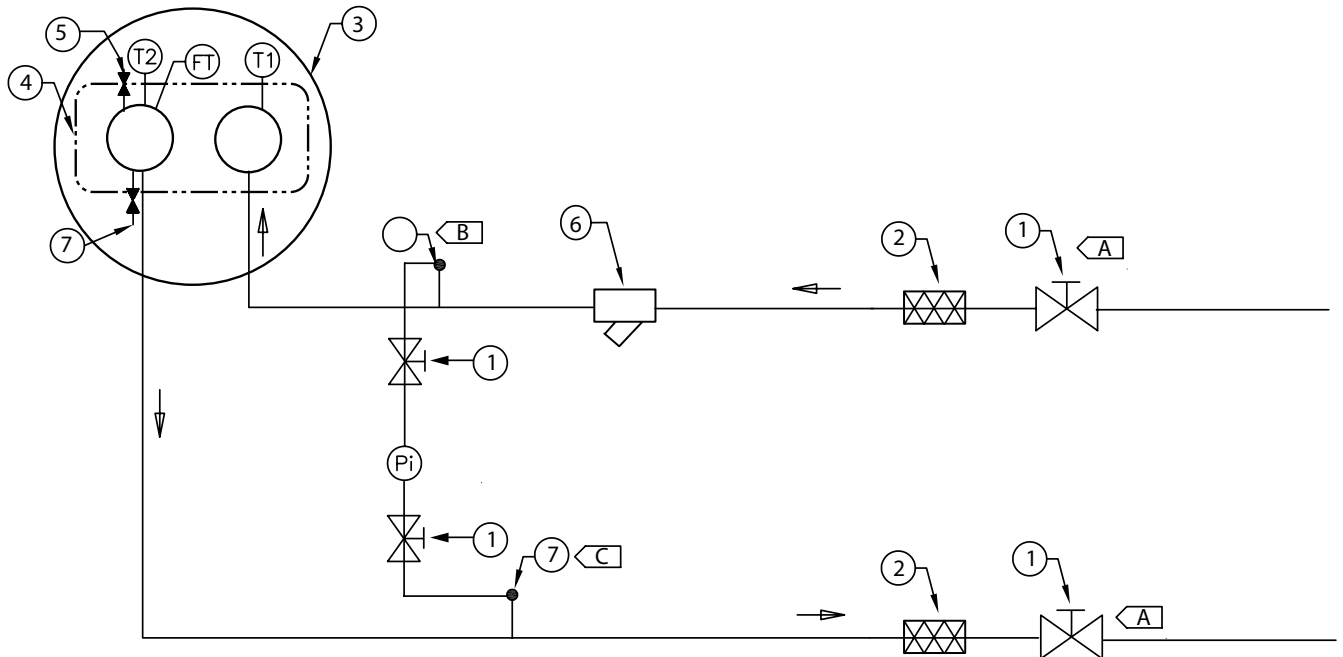

- 1 = Isolation valve
- 2 = Vibration isolators
- 3 = Evaporator – End view (2-pass)
- 4 = Evaporator Waterbox
- 5 = Vent
- 6 = Strainer
- 7 = Drain

- Pi = Pressure gauge
- FT = Water Flow Switch
- T1 = Evaporator Water Inlet Temperature Sensor
- T2 = Evaporator Water Outlet Temperature Sensor
- A = Isolate unit for initial water loop cleaning
- B = Vent must be installed at the high point of the line
- C = Drain must be installed at the low point of the line

Entering Chilled Water Piping

- Air vents to bleed the air from the system (to be placed on the highest point)
- Water pressure gauges with shutoff valves
- Vibration eliminators
- Shutoff (isolation) valves
- Thermometers if desired (temperature readings available on chiller controller display)
- Clean-out tees
- Pipe strainer

Leaving Chilled Water Piping

- Air vents to bleed the air from the system (to be placed on the highest point)
- Water pressure gauges with shut off valves
- Vibration eliminators
- Shutoff (isolation) valves
- Thermometers (temperature readings available on the chiller controller display)
- Clean-out tees
- Balancing valve
- Flow Proving Device

Drainage

A large capacity drain must be provided for water vessel drain-down during shutdown or repair. The evaporator is provided with drain connections. An air vent on top of the evaporator waterbox prevents vacuum by removing air from evaporator for complete drainage.

Drain connections and vents are also provided on header pipes for use when free-cooling option.

Evaporator configuration varies with unit size.

- 2 compressors unit: 2-pass evaporator
- 3/4 compressors unit : 1-pass evaporator

Figure 4 – Drain and vent position on evaporator

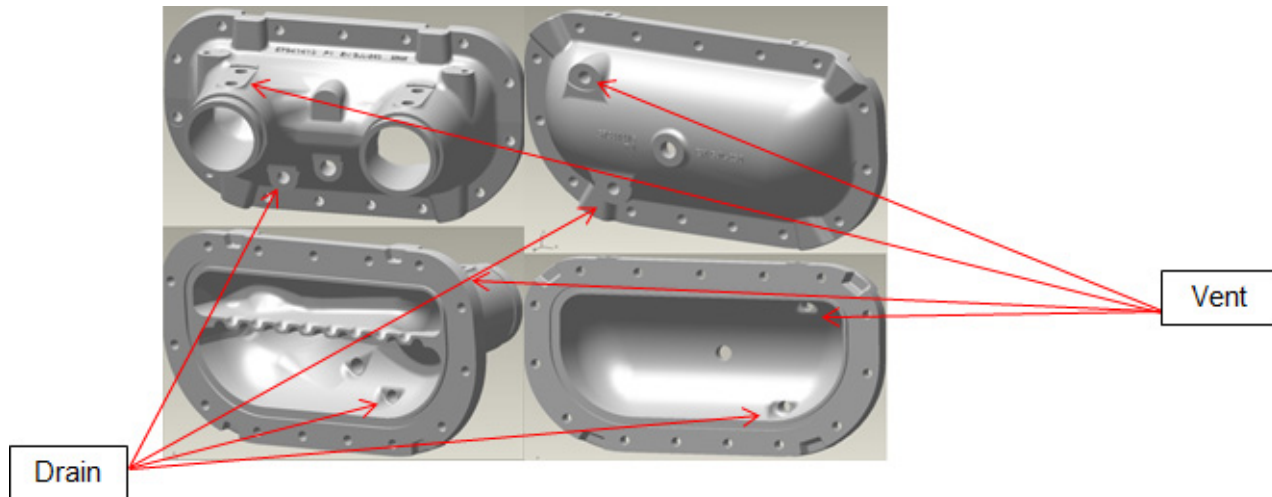
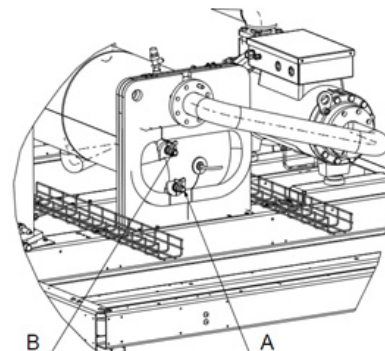
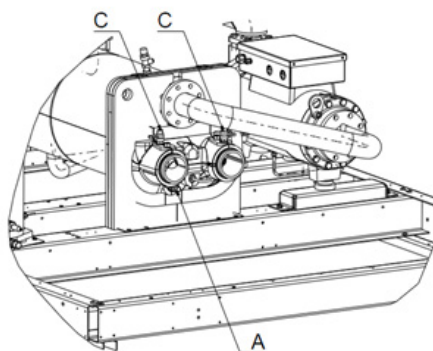

Figure 5 – Drain and air vent fitting location on the evaporator water side

Water connection side

Opposite side



A: Drain valve

B: Air vent valve

C: Air vent valve and pressure tab

Notice: Waterbox Damage!

Failure to follow these instructions could result in damage to the waterbox. Do not use Teflon® pipe tape or overtighten when installing valves, drains, plugs, and vents on cast iron waterboxes.

RTAF chillers are equipped with two drain connections, one located on each waterbox. Waterboxes also include vent connections to assist in bleeding air from the chilled water loop. These vent connections should not be assumed to be capable of venting all chilled water piping.

In order to completely remove water from the evaporator tubes and waterboxes, vent and drain connections on both waterboxes should be opened. Use pressurized air to ensure all water is removed from the evaporator. In addition, two-pass supply waterboxes should have drainage capability through supply water piping. Incomplete drainage increases the risk of damage due to expansion associated with trapped water freezing.

Note: If evaporator will be drained for winter storage, the heaters must be disconnected to prevent overheating. It is also mandatory to fulfill the drainage for winter season for unit arriving from factory.

Sufficient glycol quantity and concentration must be introduced in the lower part of the evaporator head to prevent damage from stagnating water freezing.

Pressure Gauges

Install field-supplied pressure components as shown in Figure 6. Locate pressure gauges or taps in a straight run of pipe; avoid placing them near elbow (at least at 10 pipe diameter from discontinuity).

To read manifold pressure gauges, open one valve and close the other (depending on the side of the desired reading), this eliminates errors resulting from differently calibrated gauges installed at unmatched elevations.

Pressure Relief Valves

Install a water pressure relief valve in the evaporator inlet piping between evaporator and the inlet shutoff valve. Water vessels with close-coupled shutoff valves have high potential for hydrostatic pressure buildup on a water temperature increase. Refer to applicable local codes for relief valve installation.

Evaporator Flow Switch

Specific connection and schematic wiring diagram are shipped within the unit. Some piping and control schemes, particularly those using a single water pump for both chilled and hot water, must be analyzed to determine how and/or if a flow sensing device will provide the desired operation.

Flow Switch Installation – Typical Requirements

1. Mount the switch upright, with a minimum of 10 pipe diameters of straight horizontal run on each side. Do not install close to elbows, orifices, or valves. The arrow on the switch must point in the direction of the flow. For additional information, consult the flow switch information sheet coming with the part.
2. To prevent switch fluttering, remove all air from the water system. Tracer UC800 provides a 6 second time delay after a “loss-of-flow” diagnostic before shutting the unit down. Contact a Trane service representative if nuisance machine shutdowns persist.
3. Adjust the switch to open when water flow falls below nominal values. Evaporator data is given on the General Information Section. Flow Switch contacts are closed on proof of water flow.
4. Install a pipe strainer in the entering evaporator-water line to protect components.

CAUTION! Control voltage from the chiller to the flow proving device is 110V AC.

Notice: Evaporator Damage!

If the microprocessor calls for a pump to start and water does not flow, the evaporator may be damaged catastrophically. It is the responsibility of the installing contractor and/or the customer to ensure that a pump will always be running when called upon by the chiller controls.

Evaporator Waterside

Figure 6a – Evaporator water pressure drop with standard tubes - Sizes 090-330

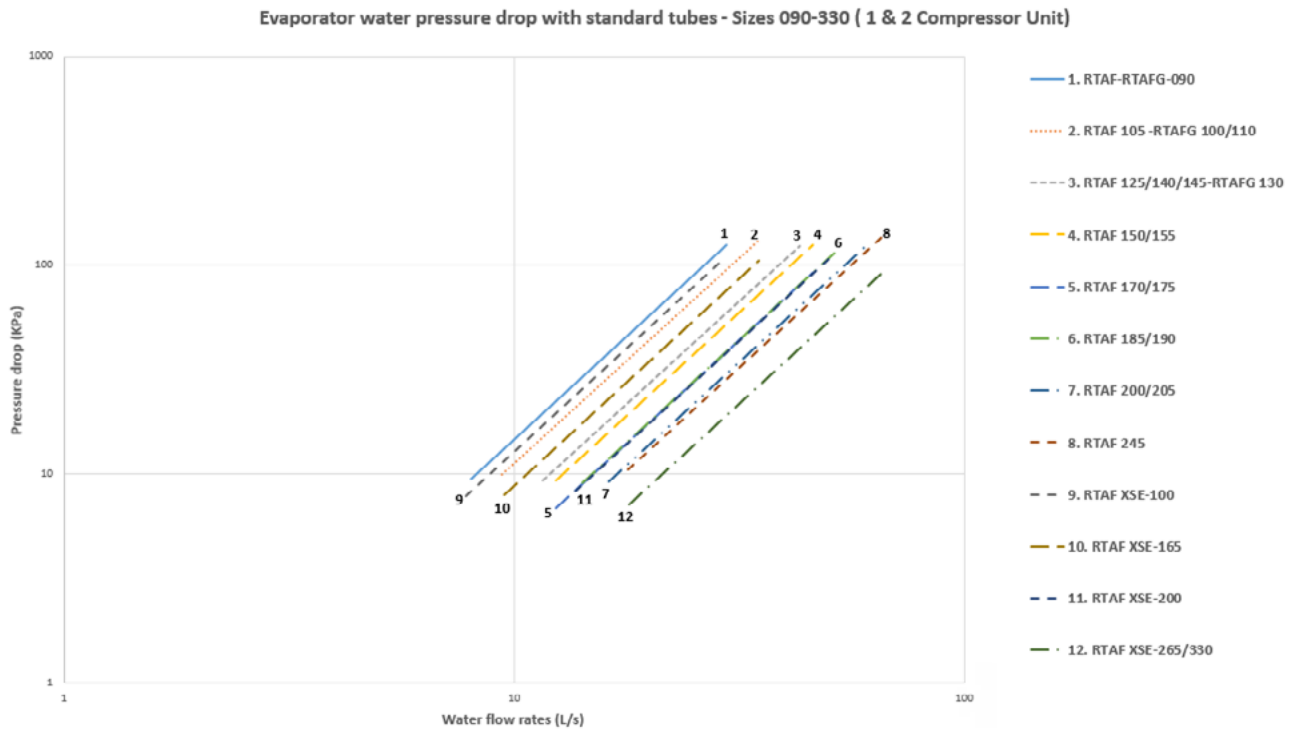

Evaporator Waterside

Figure 6b – Evaporator water pressure drop with standard tubes - Sizes 210-550

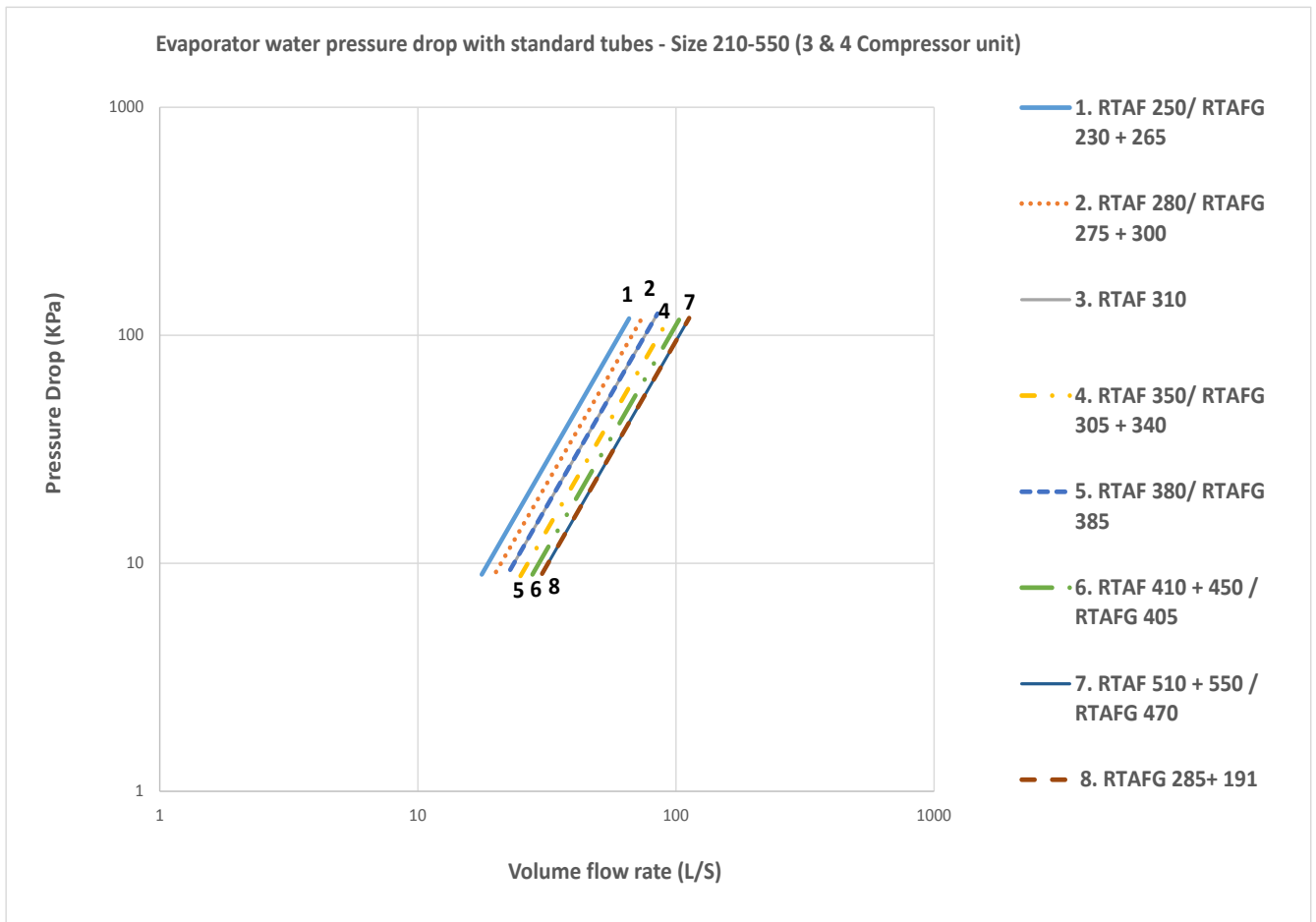

Evaporator Waterside

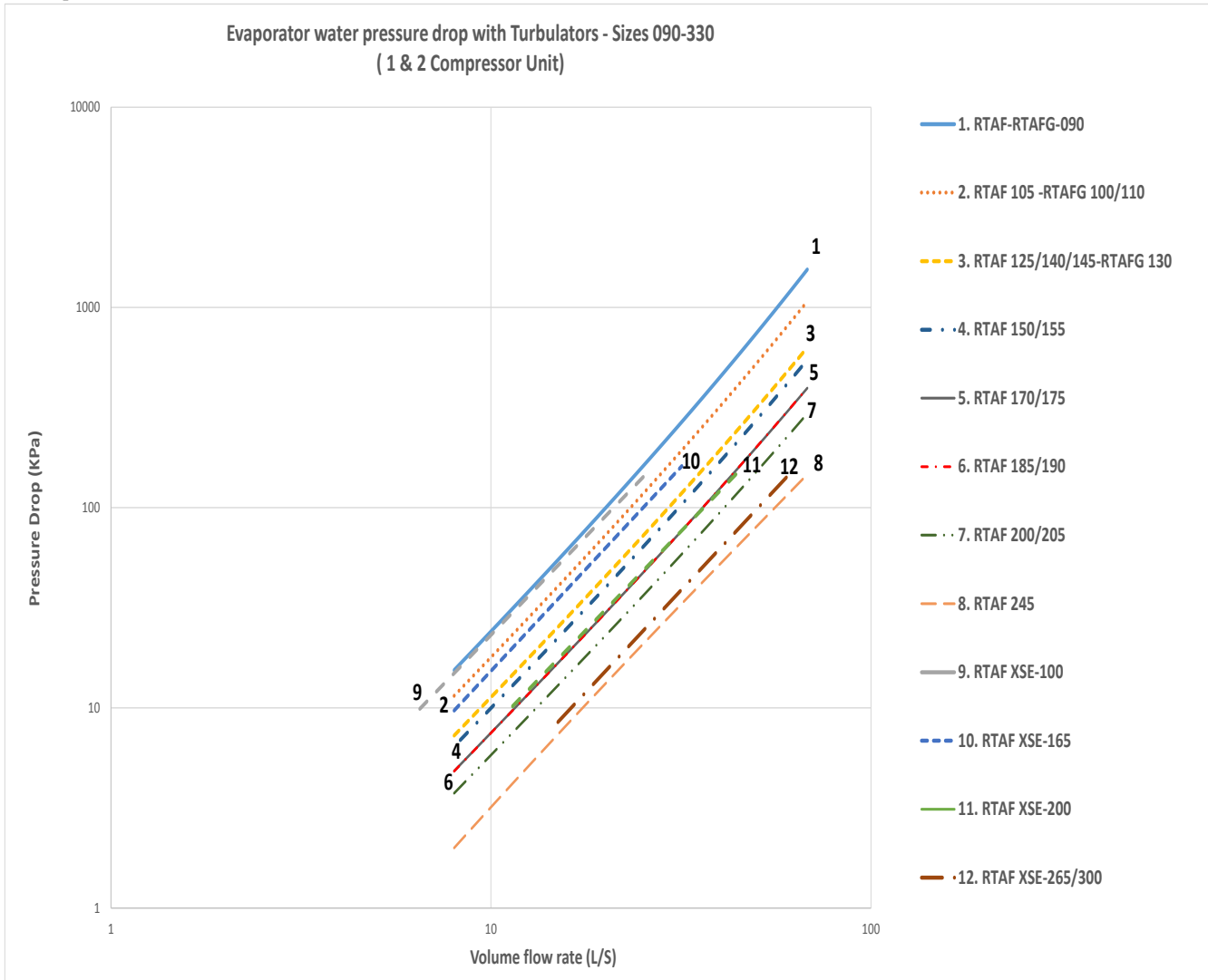

Evaporator Waterside

Figure 7b – Evaporator water pressure drop with Turbulators - Sizes 210-550

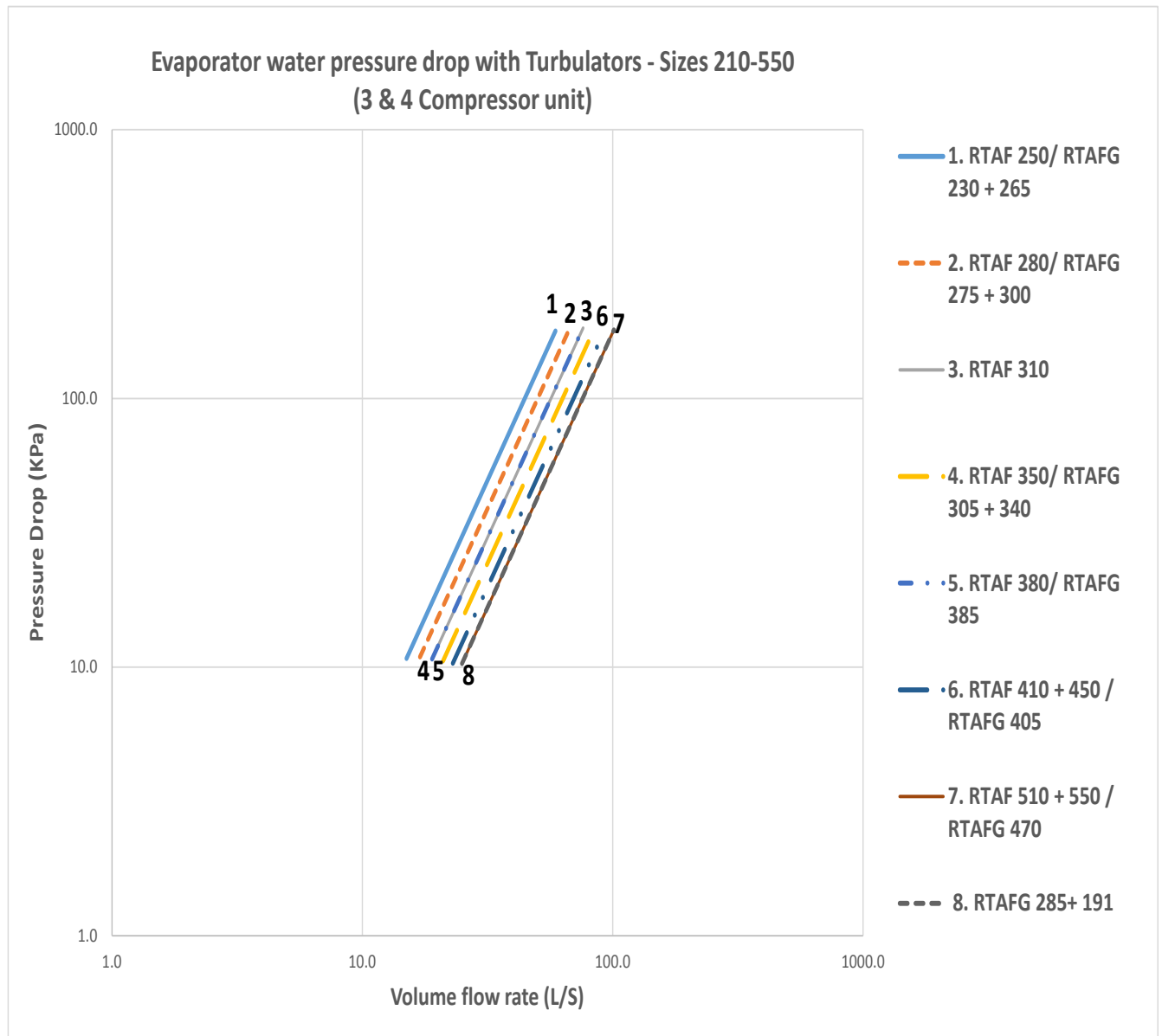

Optional Integrated Pump Package

Installation – Mechanical

Chiller can be ordered with an optional integrated hydraulic module. In this case, chiller will be provided with the following components factory mounted and tested:

- Twin centrifugal water pump, Low pressure or High pressure (option)
- Water strainer to protect the pump against impurities in the circuit
- Expansion module with expansion vessel and pressure relief valve sufficient to ensure the expansion of the water loop ability
- Thermal insulation for antifreeze protection
- Balancing valve for equilibrate the flow of water circuit
- Drain valve
- Temperature sensor

Note: A pressure switch device to detect lack of water is not included in the pump package. Installation of this type of device is highly recommended to avoid sealing damage due to operation of pump without enough water.

On chiller sizes 090, 105, 125 and 250 standard efficiency; the suction pipe is not installed on the pump flange for shipping purpose. This operation will have to be done once the chiller is delivered on job site according to the following figure. Fasteners and gaskets are fixed to the pipe assembly.

Figure 8 – Shipping arrangement and Operational arrangement

Unit size 090-125

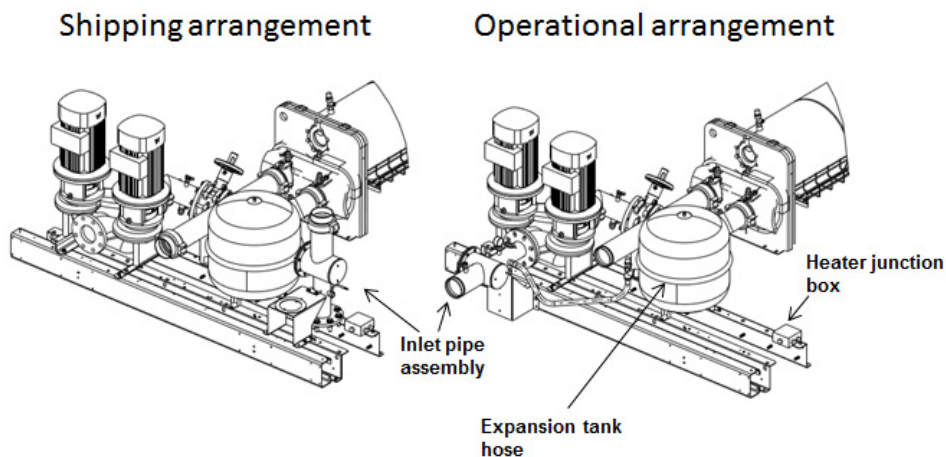

Unit size 250

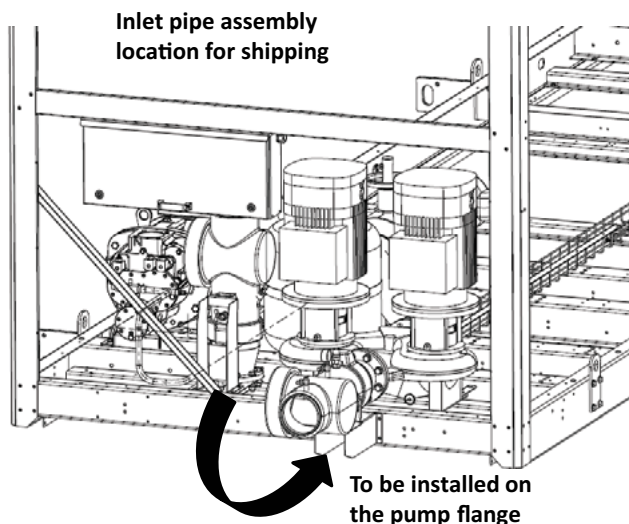
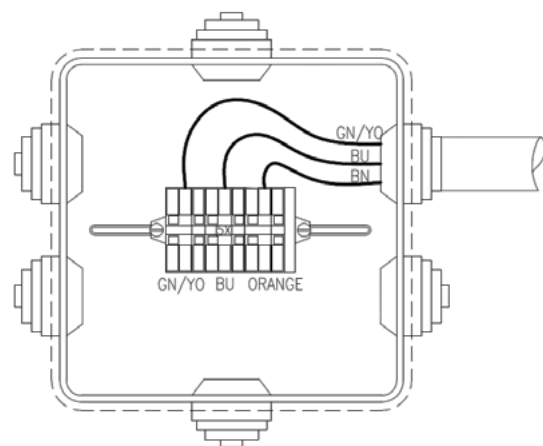

Figure 9 – The junction box



The heater cable will be routed along the frame cross member to be connected to the heater terminal block located inside the junction box according to the following figure.

Optional Integrated Pump Package

Pump Curves

In the figures below are described Pump Curves with a combination of Standard Head- High Head with standard tubes and turbulators inside the evaporator for the whole unit range, sizes 090 to 245 and sizes 250 to 450.

Figure 10 – Pump Curve - Sizes 090-245 - Standard Head - Standard Tube

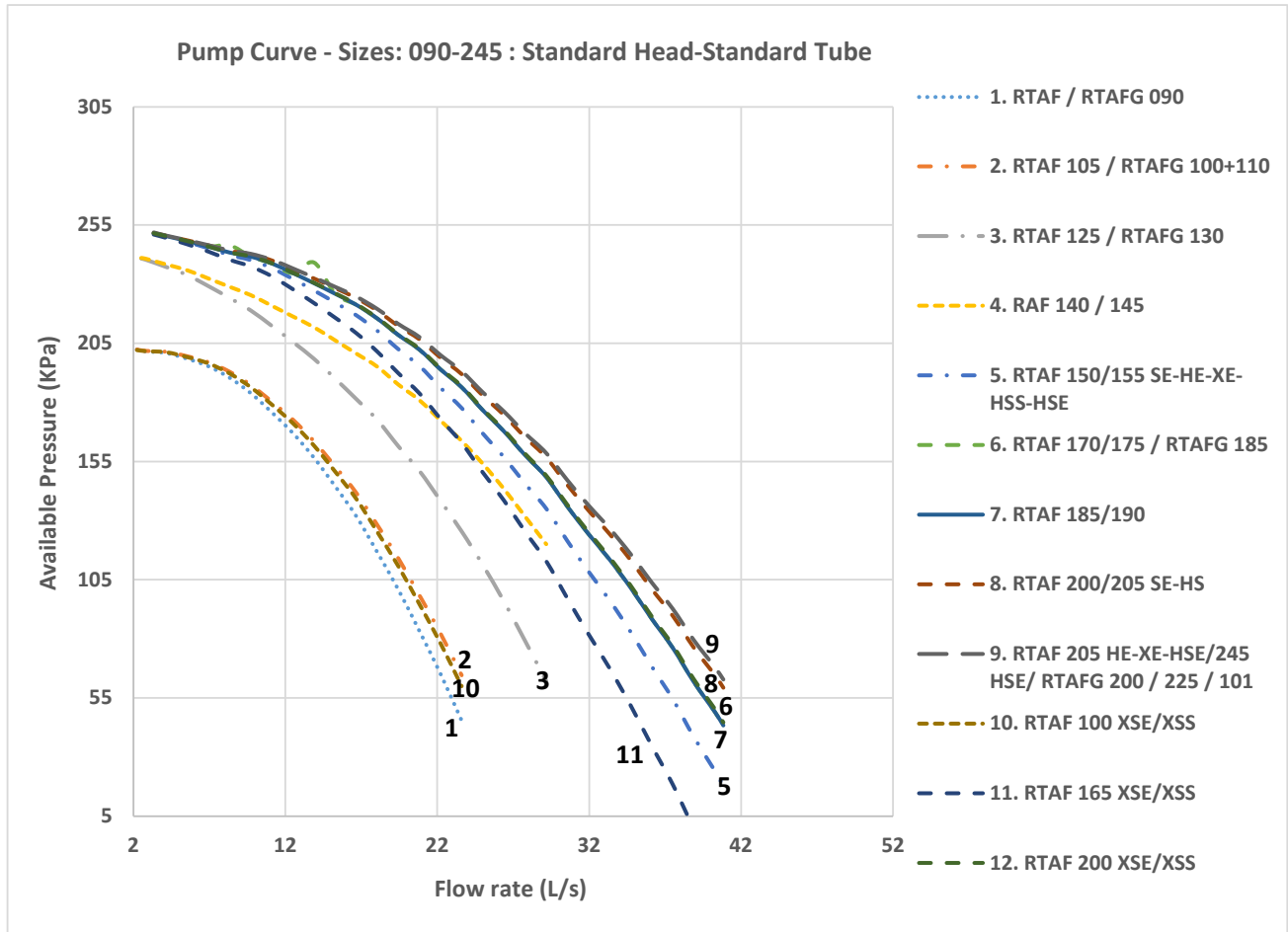

Optional Integrated Pump Package

Figure 11 – Pump Curve - Sizes 090-245 - High Head - Standard Tube

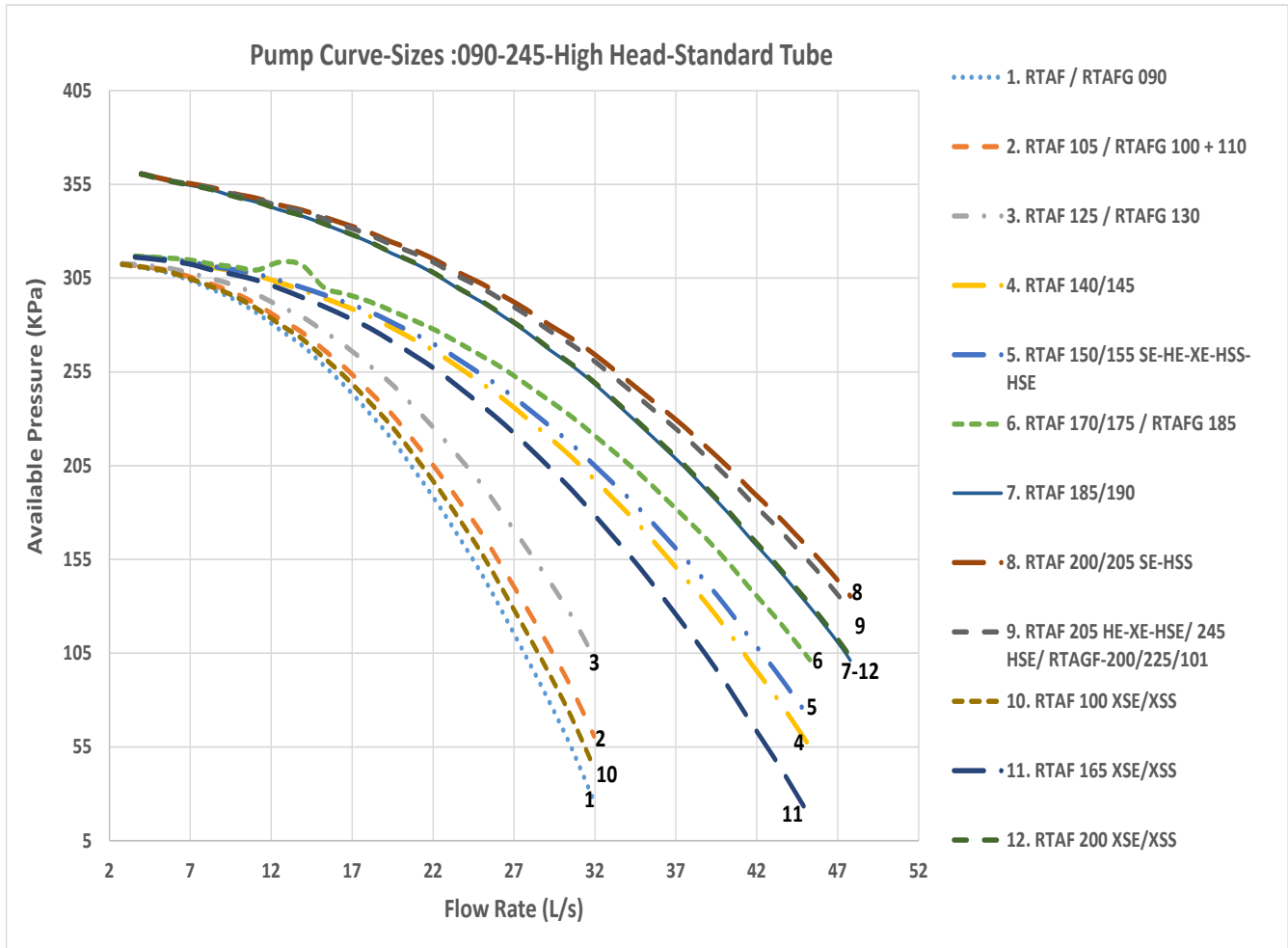

Optional Integrated Pump Package

Figure 12 – Pump Curve - Sizes 250 - 450 - Standard Head - Standard Tubes

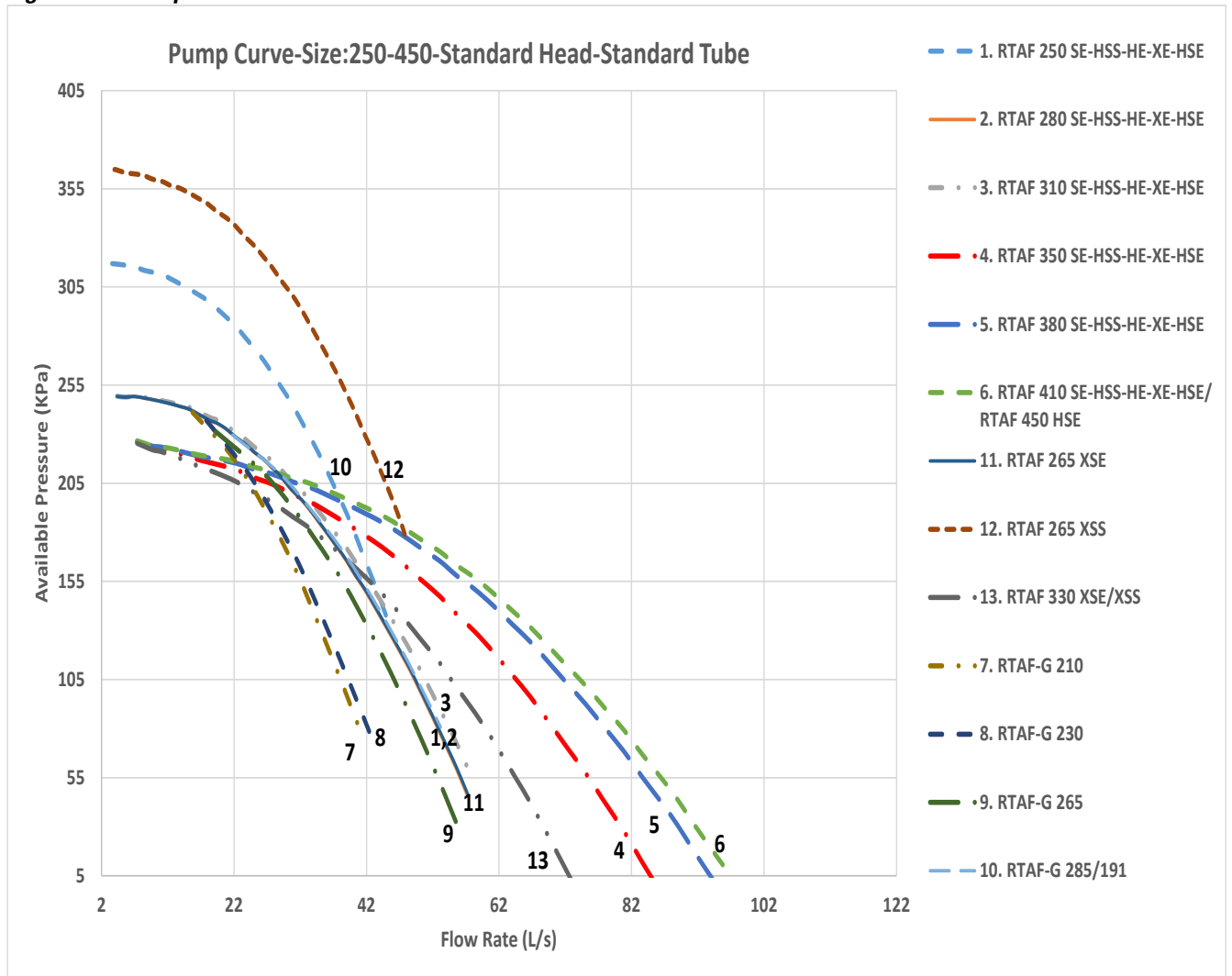

Optional Integrated Pump Package

Figure 13 – Pump Curve - Sizes 250 - 280 - 310 - High Head - Standard Tubes

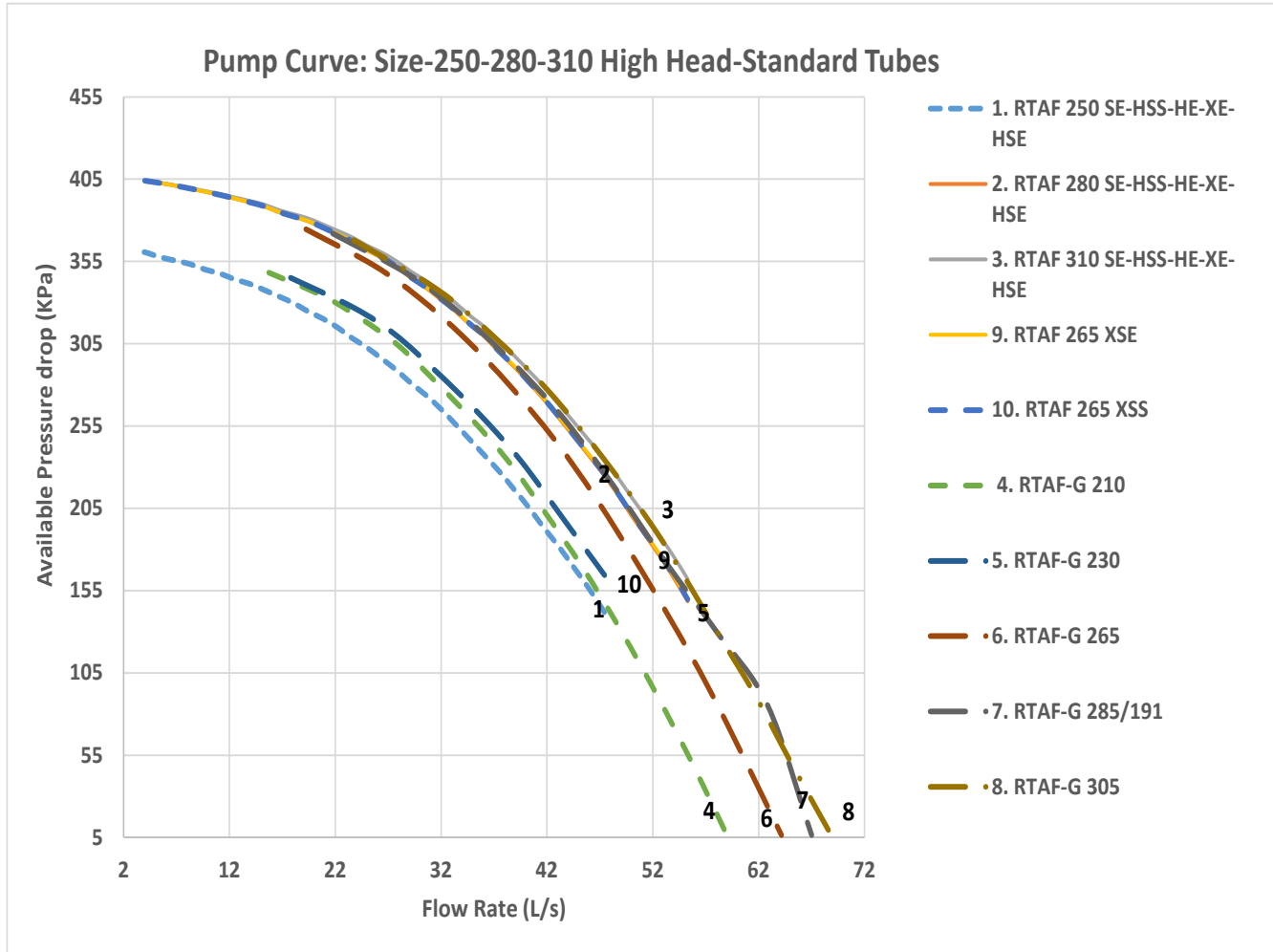

Optional Integrated Pump Package

Figure 14 – Pump Curve - Sizes 090-245 - Standard Head - Tube with Turbulators

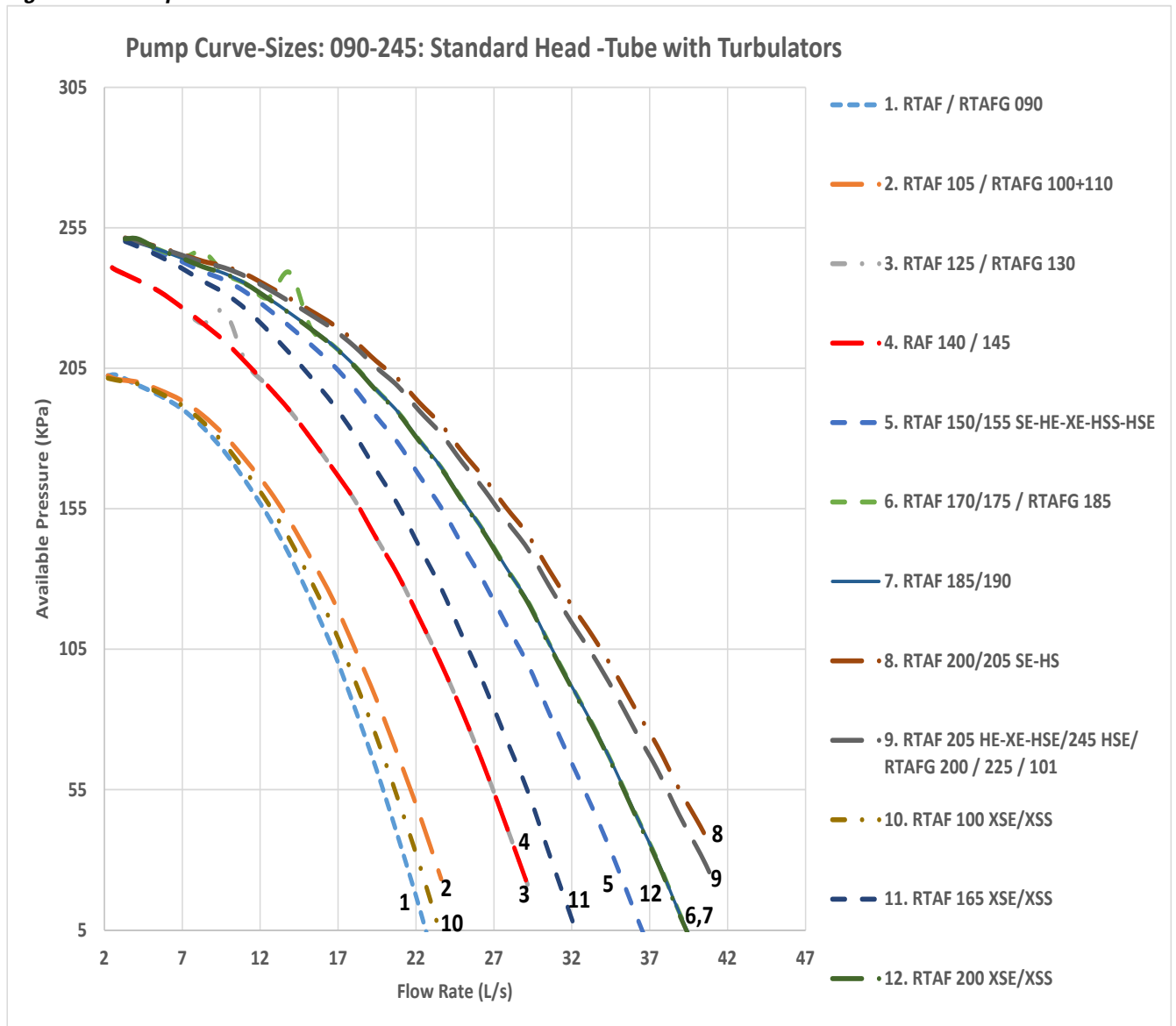

Optional Integrated Pump Package

Figure 15 – Pump Curve - Sizes 090-245 - High Head - Tube with Turbulators

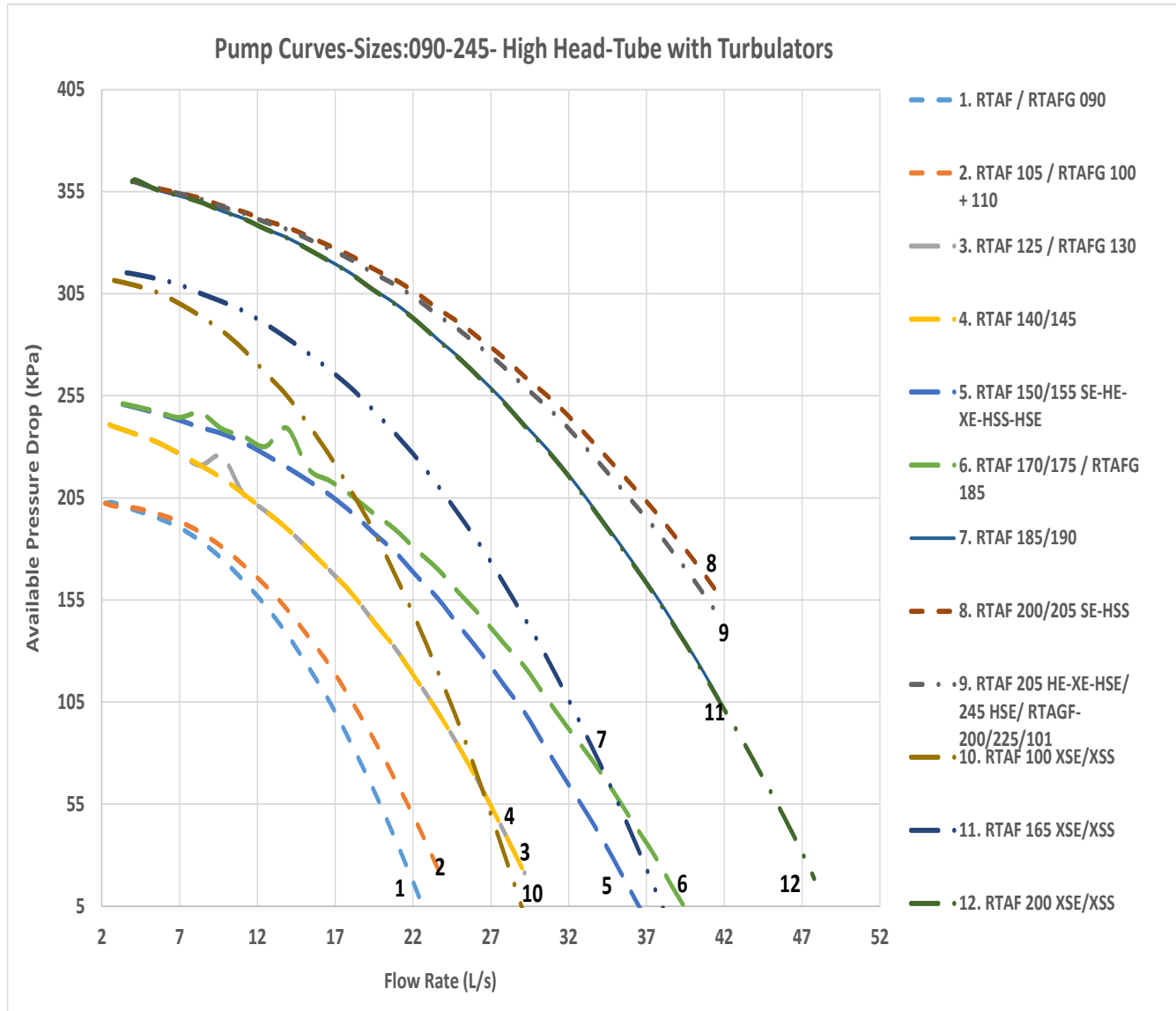

Optional Integrated Pump Package

Figure 16 – Pump Curve - Sizes 250 - 450 - Standard Head - Tubes with Turbulators

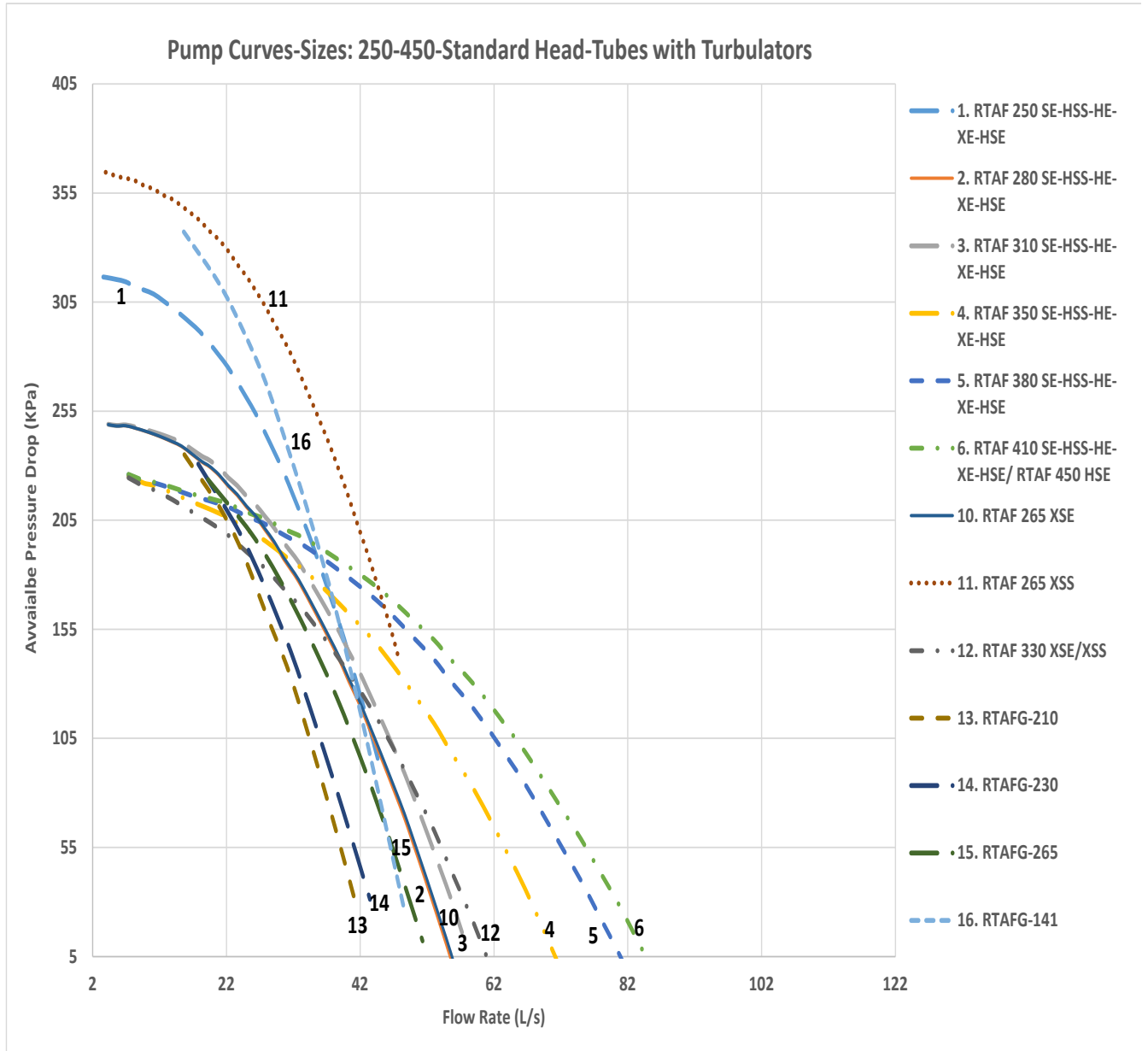

Optional Integrated Pump Package

Figure 17 – Pump Curve - Sizes 250 - 280 - 310 - High Head - Standard Tubes

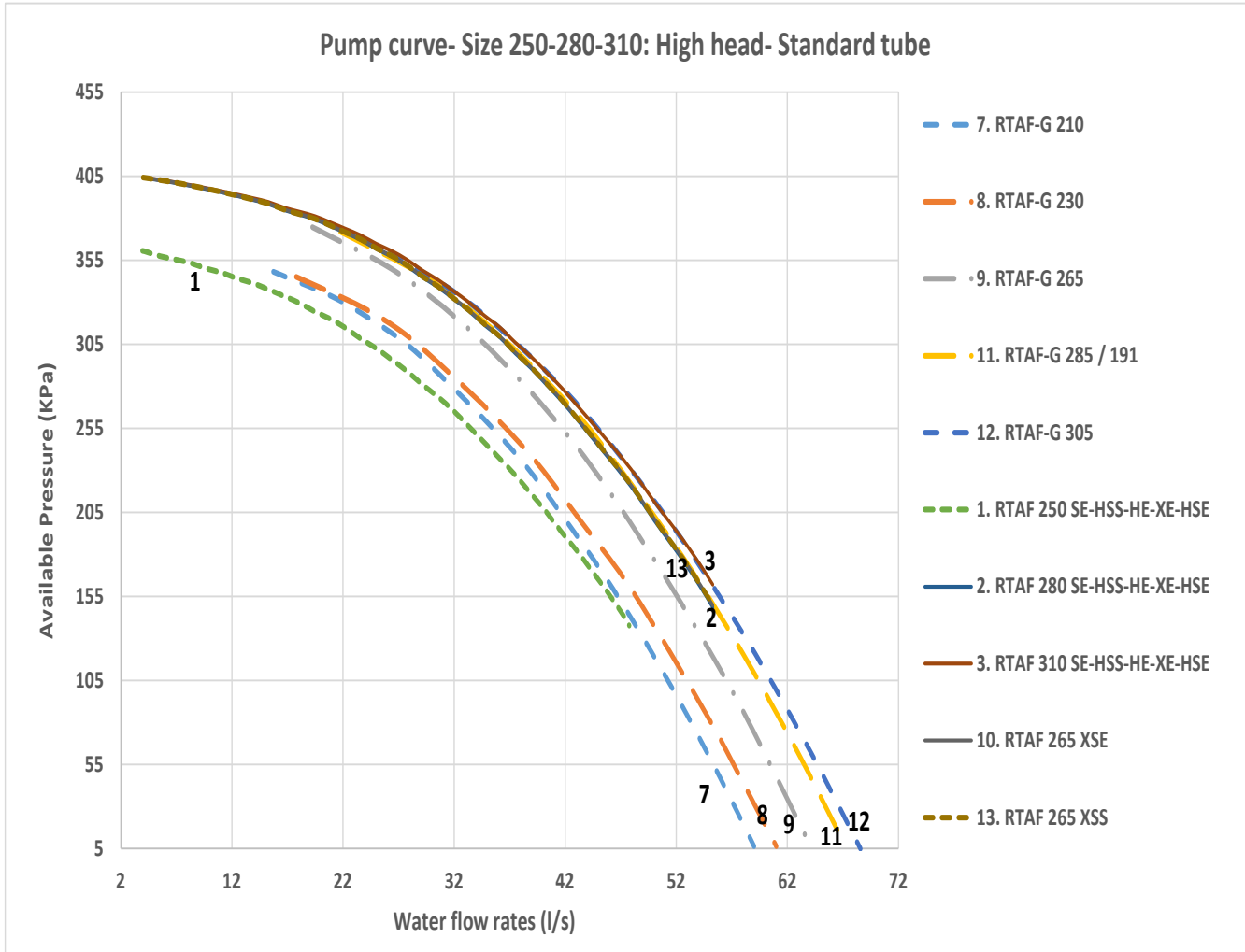

Note: High head pump is not available for sizes 350, 370, 380, 400, 410, 415, 450, 510 and 550.

Partial Heat Recovery

Heat recovery option is made with a plate heat exchanger in series with the air-cooled condenser. This heat exchanger benefits the discharge gas superheat as well as a part of the condensing gas heat to be transferred to hot water system.

PHR General data

Table 33 – General Data Partial Heat Recovery (PHR) RTAF with Fix Speed Compressor - R134a

PHR		RTAF 090	RTAF 105	RTAF 125	RTAF 140	RTAF 145	RTAF 150	RTAF 155	RTAF 170	RTAF 175	RTAF 185	RTAF 190
Efficiency Level(s)		SE/HE/XE	SE/HE/XE	SE/HE/XE	SE/HE/XE	SE/HE/XE	SE/HE/XE	SE/HE/XE	SE/HE/XE	SE/HE/XE	SE/HE/XE	SE/HE/XE
Heating capacity (1)												
Gross heating Capacity (1)	(kW)	82	94	110	127	131	136	141	146	154	164	169
Condenser												
Type		Stainless steel Copper Brazed plate Heat exchanger										
Circuit 1 BPHE		B3-095 28pl	B3-095 28pl	B3-095 28pl	B3-095 28pl	B3-095 28pl	B3-095 40pl	B3-095 40pl	B3-095 40pl	B3-095 40pl	B3-095 40pl	B3-095 40pl
Circuit 2 BPHE		B3-095 28pl	B3-095 28pl	B3-095 28pl	B3-095 28pl	B3-095 28pl	B3-095 40pl	B3-095 40pl	B3-095 40pl	B3-095 40pl	B3-095 40pl	B3-095 40pl
Nominal water connection size (Grooved coupling)	(in) - (mm)	2" - 50mm	2" - 50mm	2" - 50mm	2" - 50mm	2" - 50mm	2" - 50mm	2" - 50mm	2" - 50mm	2" - 50mm	2" - 50mm	2" - 50mm
Water content volume	(l)	10.0	10.0	10.0	10.0	10.0	12.0	12.0	12.0	12.0	12.0	12.0

PHR		RTAF 200	RTAF 205	RTAF 245	RTAF 250	RTAF 280	RTAF 310	RTAF 350	RTAF 355	RTAF 380	RTAF 410	RTAF 450
Efficiency Level(s)		SE/HE/XE	SE/HE/XE	SE/HE/XE	SE/HE/XE	SE/HE/XE	SE/HE/XE	SE/HE/XE	SE/HE/XE	SE/HE/XE	SE/HE/XE	SE/HE/XE
Heating capacity (1)												
Gross heating Capacity (1)	(kW)	177	183	198	215	244	269	299	294	331	362	398
Condenser												
Type		Stainless steel Copper Brazed plate Heat exchanger										
Circuit 1 BPHE		B3-095 40pl	B3-095 40pl	B3-095 40pl	B3-095 70pl	B3-095 70pl	B3-095 70pl	B3-095 70pl	B3-095 70pl	B3-095 70pl	B3-095 70pl	B3-095 70pl
Circuit 2 BPHE		B3-095 40pl	B3-095 40pl	B3-095 40pl	B3-095 40pl	B3-095 40pl	B3-095 40pl	B3-095 70pl	B3-095 40pl	B3-095 70pl	B3-095 70pl	B3-095 70pl
Nominal water connection size (Grooved coupling)	(in) - (mm)	2" - 50mm	2" - 50mm	2" - 50mm	2" - 50mm	2" - 50mm	2" - 50mm	2" - 50mm	2" - 50mm	2" - 50mm	2" - 50mm	2" - 50mm
Water content volume	(l)	12.0	12.0	12.0	30.0	30.0	30.0	35.0	30.0	35.0	35.0	35.0

Table 34 – General Data Partial Heat Recovery (PHR) RTAF with Variable Speed Compressor (with VFD) - R134a

PHR		RTAF 090	RTAF 105	RTAF 125	RTAF 145	RTAF 155	RTAF 175	RTAF 190	RTAF 205	RTAF 245	RTAF 250	RTAF 280
Efficiency Level(s)		HSE/HSS	HSE/HSS	HSE/HSS	HSE/HSS	HSE/HSS	HSE/HSS	HSE/HSS	HSE/HSS	HSE/HSS	HSE/HSS	HSE/HSS
Heating capacity (1)												
Gross heating Capacity (1)	(kW)	83	96	113	133	144	160	174	187	218	221	250
Condenser												
Type		Stainless steel Copper Brazed plate Heat exchanger										
Circuit 1 BPHE		B3-095 28pl	B3-095 28pl	B3-095 28pl	B3-095 28pl	B3-095 40pl	B3-095 40pl	B3-095 40pl	B3-095 40pl	B3-095 40pl	B3-095 70pl	B3-095 70pl
Circuit 2 BPHE		B3-095 28pl	B3-095 28pl	B3-095 28pl	B3-095 28pl	B3-095 40pl	B3-095 40pl	B3-095 40pl	B3-095 40pl	B3-095 40pl	B3-095 40pl	B3-095 40pl
Nominal water connection size (Grooved coupling)	(in) - (mm)	2" - 50mm	2" - 50mm	2" - 50mm	2" - 50mm	2" - 50mm	2" - 50mm	2" - 50mm	2" - 50mm	2" - 50mm	2" - 50mm	2" - 50mm
Water content volume	(l)	10.0	10.0	10.0	10.0	12.0	12.0	12.0	12.0	12.0	30.0	30.0

PHR		RTAF 310	RTAF 350	RTAF 380	RTAF 410	RTAF 450	RTAF 100	RTAF 165	RTAF 200	RTAF 265	RTAF 330	
Efficiency Level(s)		HSE/HSS	HSE/HSS	HSE/HSS	HSE/HSS	HSE/HSS	XSE/XSS	XSE/XSS	XSE/XSS	XSE/XSS	XSE/XSS	
Heating capacity (1)												
Gross heating Capacity (1)	(kW)	280	312	340	369	399	92	147	182	246	306	
Condenser												
Type		Stainless steel Copper Brazed plate Heat exchanger										
Circuit 1 BPHE		B3-095 70pl	B3-095 70pl	B3-095 70pl	B3-095 70pl	B3-095 70pl	B3-095 40pl	B3-095 70pl	B3-095 40pl	B3-095 40pl	B3-095 70pl	
Circuit 2 BPHE		B3-095 40pl	B3-095 70pl	B3-095 70pl	B3-095 70pl	B3-095 70pl			B3-095 40pl	B3-095 70pl	B3-095 70pl	
Nominal water connection size (Grooved coupling)	(in) - (mm)	2" - 50mm	2" - 50mm	2" - 50mm	2" - 50mm	2" - 50mm	2" - 50mm	2" - 50mm	2" - 50mm	2" - 50mm	2" - 50mm	
Water content volume	(l)	30.0	35.0	35.0	35.0	35.0	10.0	10.0	15.0	30.0	30.0	

(1) Indicative performance at Evaporator water temperature : 12°C/7°C- Condenser air temperature 35°C- Condenser water temperature 40°C/45°C .



Partial Heat Recovery

PHR General data

Table 35 – General Data Partial Heat Recovery (PHR) RTAF with Variable Speed Compressor - R1234ze

PHR		RTAF 090	RTAF 100	RTAF 110	RTAF 120	RTAF 130	RTAF 145	RTAF 155	RTAF 185	RTAF 200	RTAF 210	RTAF 225
Efficiency Level(s)		HSS/ HSE	HSS/ HSE	HSS/ HSE	HSS/ HSE	HSS/ HSE	HSS/ HSE	HSS/ HSE	HSS/ HSE	HSS/ HSE	HSS/ HSE	HSS/ HSE
Heating capacity (1)												
Gross heating Capacity (1)	(kW)	81	89	98	106	114	127	138	153	180	184	208
Condenser												
Type		Stainless steel Copper Brazed plate Heat exchanger (Danfoss)										
Circuit 1 BPHE		B3-095 28pl	B3-095 28pl	B3-095 28pl	B3-095 28pl	B3-095 28pl	B3-095 28pl	B3-095 40pl	B3-095 40pl	B3-095 40pl	B3-095 70pl	B3-095 40pl
Circuit 2 BPHE		B3-095 28pl	B3-095 28pl	B3-095 28pl	B3-095 28pl	B3-095 28pl	B3-095 28pl	B3-095 40pl	B3-095 40pl	B3-095 40pl	B3-095 40pl	B3-095 40pl
Nominal water connection size (Grooved coupling)	(in) - (mm)	2" - 50mm	2" - 50mm	2" - 50mm	2" - 50mm	2" - 50mm	2" - 50mm	2" - 50mm	2" - 50mm	2" - 50mm	2" - 50mm	2" - 50mm
Water content volume	(l)	10.0	10.0	10.0	10.0	10.0	10.0	12.0	12.0	10.0	10.0	12.0

PHR		RTAF 230	RTAF 265	RTAF 275	RTAF 285	RTAF 300	RTAF 305	RTAF 340	RTAF 385	RTAF 405	RTAF 470
Efficiency Level(s)		HSS/HSE	HSS/HSE	HSS/HSE	HSS/HSE	HSS/HSE	HSS/HSE	HSS/HSE	HSS/HSE	HSS/HSE	HSE
Heating capacity (1)											
Gross heating Capacity (1)	(kW)	208	225	252	254	279	277	302	330	359	425
Condenser											
Type		Stainless steel Copper Brazed Plates Heat Exchanger (Danfoss)									
Circuit 1 BPHE		B3-095 70pl	B3-095 70pl	B3-095 70pl	B3-095 70pl	B3-095 70pl	B3-095 70pl	B3-095 70pl	B3-095 70pl	B3-095 70pl	B3-095 70pl
Circuit 2 BPHE		B3-095 40pl	B3-095 40pl	B3-095 40pl	B3-095 70pl	B3-095 40pl	B3-095 70pl	B3-095 70pl	B3-095 70pl	B3-095 70pl	B3-095 70pl
Nominal water connection size (Grooved coupling)	(in) - (mm)	2" - 50mm	2" - 50mm	2" - 50mm	2" - 50mm	2" - 50mm	2" - 50mm	2" - 50mm	2" - 50mm	2" - 50mm	2" - 50mm
Water content volume	(l)	30	30	30	35	30	35	35	35	35	35

PHR General data

Table 36 – General Data Partial Heat Recovery (PHR) RTAF with Fix Speed Compressor - R1234ze

PHR		RTAF 90	RTAF 100	RTAF 110	RTAF 120	RTAF 130	RTAF 145	RTAF 155
Efficiency Level(s)		SE/HE/XE	SE/HE/XE	SE/HE/XE	SE/HE/XE	SE/HE/XE	SE/HE/XE	SE/HE/XE
Heating capacity (1)								
Gross heating Capacity (1)	(kW)	82	89	97	105	113	126	136
Condenser								
Type		Stainless steel Copper Brazed plate Heat exchanger (Danfoss)						
Circuit 1 BPHE		B3-095 28pl	B3-095 28pl	B3-095 28pl	B3-095 28pl	B3-095 28pl	B3-095 28pl	B3-095 40pl
Circuit 2 BPHE		B3-095 28pl	B3-095 28pl	B3-095 28pl	B3-095 28pl	B3-095 28pl	B3-095 28pl	B3-095 40pl
Nominal water connection size (Grooved coupling)	(in) - (mm)	2" - 50mm	2" - 50mm	2" - 50mm	2" - 50mm	2" - 50mm	2" - 50mm	2" - 50mm
Water content volume	(l)	10.0	10.0	10.0	10.0	10.0	10.0	12.0

PHR		RTAF 185	RTAF 210	RTAF 230	RTAF 265	RTAF 285	RTAF 305	RTAF 340
Efficiency Level(s)		SE/HE/XE	SE/HE/XE	SE/HE/XE	SE/HE/XE	SE/HE/XE	SE/HE/XE	SE/HE/XE
Heating capacity (1)								
Gross heating Capacity (1)	(kW)	151	182	202	222	249	271	297
Condenser								
Type		Stainless steel Copper Brazed Plates Heat Exchanger (Danfoss)						
Circuit 1 BPHE		B3-095 40pl	B3-095 70pl	B3-095 70pl	B3-095 70pl	B3-095 70pl	B3-095 70pl	B3-095 70pl
Circuit 2 BPHE		B3-095 40pl	B3-095 40pl	B3-095 40pl	B3-095 40pl	B3-095 70pl	B3-095 70pl	B3-095 70pl
Nominal water connection size (Grooved coupling)	(in) - (mm)	2" - 50mm	2" - 50mm	2" - 50mm	2" - 50mm	2" - 50mm	2" - 50mm	2" - 50mm
Water content volume	(l)	12	30	30	30	35	35	35

(1) Indicative performance at Evaporator water temperature : 12°C/7°C- Condenser air temperature 35°C- Condenser water temperature 40°C/45°C . For accurate value refer to OWU.

Partial Heat Recovery

Figure 18 – Water pressure drop - heat recovery heat exchanger

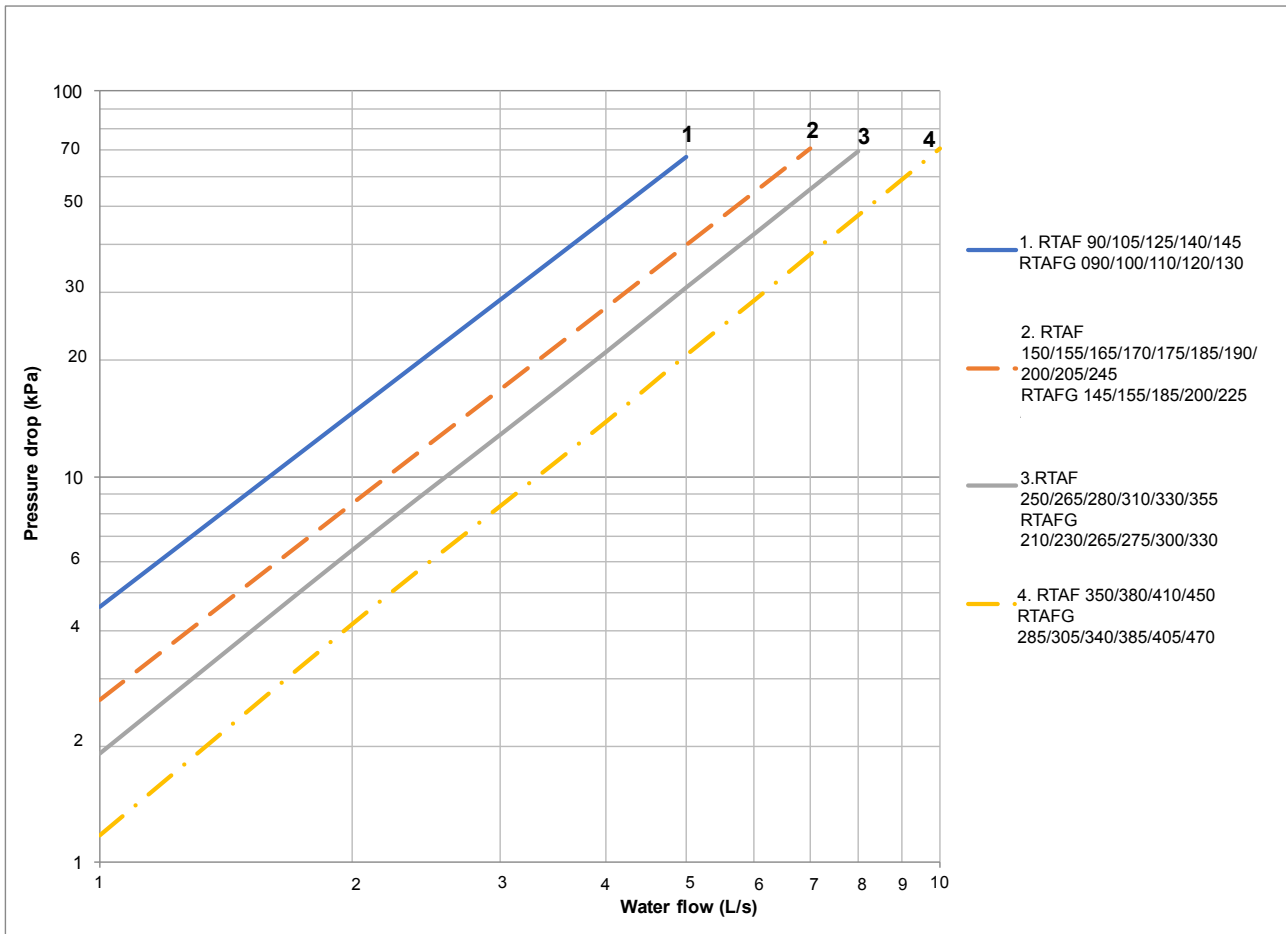



Total Heat Recovery

THR General data

Table 37 – General Data Total Heat Recovery (THR) RTAF with Fix Speed Compressor - R134a

THR		RTAF 090	RTAF 105	RTAF 125	RTAF 140	RTAF 145	RTAF 150	RTAF 155	RTAF 170	RTAF 175	RTAF 185	RTAF 190
Efficiency Level(s)		SE/HE/XE	SE/HE/XE	SE/HE/XE	SE/HE/XE	SE/HE/XE	SE/HE/XE	SE/HE/XE	SE/HE/XE	SE/HE/XE	SE/HE/XE	SE/HE/XE
Heating capacity (1)												
Gross heating Capacity (1)	(kW)	885	378	443	527	612	612	681	681	743	751	811
Condenser												
Type		Stainless steel Copper Brazed plate Heat exchanger										
Circuit 1 BPHE		B56N-W 112pl	B56N-W 112pl	B56N-W 112pl	B56N-W 112pl	B56N-W 112pl	B56N-W 176pl	B56N-W 176pl	B56N-W 176pl	B56N-W 176pl	B56N-W 176pl	B56N-W 176pl
Circuit 2 BPHE		B56N-W 112pl	B56N-W 112pl	B56N-W 112pl	B56N-W 112pl	B56N-W 112pl	B56N-W 176pl	B56N-W 176pl	B56N-W 176pl	B56N-W 176pl	B56N-W 176pl	B56N-W 176pl
Nominal water connection size (Grooved coupling)	(in) - (mm)	4" - 100mm	4" - 100mm	4" - 100mm	4" - 100mm	4" - 100mm	5" - 125mm	5" - 125mm	5" - 125mm	5" - 125mm	5" - 125mm	5" - 125mm
Water content volume (THR Full)	(l)	95.0	95.0	95.0	95.0	95.0	128.0	128.0	128.0	128.0	128.0	128.0
Water Content Volume (THR only)	(l)	33.0	33.0	33.0	33.0	33.0	52.0	52.0	52.0	52.0	52.0	52.0
Antifreeze Heater	(W)	900	900	900	900	900	900	900	900	900	900	900
BPHE heaters	(W)	132	132	132	132	132	132	132	132	132	132	132

THR		RTAF 200	RTAF 205	RTAF 250	RTAF 280	RTAF 310	RTAF 350	RTAF 355	RTAF 380	RTAF 410	RTAF 450						
Efficiency Level(s)		SE/HE/XE	SE/HE/XE	SE HE/HE	SE HE/HE	SE HE/HE	SE HE/HE	SE/HE/XE	SE HE/HE	SE HE/HE	SE/HE/XE						
Heating capacity (1)																	
Gross heating Capacity (1)	(kW)	811	887	1047	1035	1180	1160	1321	1295	1475	1452	1470	1618	1590	1760	1727	1936
Condenser																	
Type		Stainless steel Copper Brazed plate Heat exchanger															
Circuit 1 BPHE		B56N-W 176pl	B56N-W 176pl	B427L 318pl	B427L 318pl	B427L 318pl	B427L 318pl	B427L 318pl	B427L 318pl	B427L 318pl	B427L 318pl	B427L 318pl					
Circuit 2 BPHE		B56N-W 176pl	B56N-W 176pl	B56N-W 176pl	B56N-W 176pl	B56N-W 176pl	B427L 318pl	B56N-W 176pl	B427L 318pl	B427L 318pl	B427L 318pl	B427L 318pl					
Nominal water connection size (Grooved coupling)	(in) - (mm)	5" - 125mm	5" - 125mm	6" - 150mm	6" - 150mm	6" - 150mm	6" - 150mm	6" - 150mm	6" - 150mm	6" - 150mm	6" - 150mm	6" - 150mm					
Water content volume (THR Full)	(l)	128.0	128.0	200	200	200	230	200	230	230	230	230					
Water Content Volume (THR only)	(l)	52.0	52.0	91	91	91	129	91	129	129	129	129					
Antifreeze Heater	(W)	900	900	900	900	900	900	900	900	900	900	900					
BPHE heaters	(W)	132	132	165	165	165	165	165	165	200	200	200					

Table 38 – General Data Total Heat Recovery (THR) RTAF with Variable Speed Compressor (with VFD) - R134a

THR		RTAF 090	RTAF 105	RTAF 125	RTAF 140	RTAF 145	RTAF 150	RTAF 155	RTAF 170	RTAF 175	RTAF 185	RTAF 190	RTAF 200
Efficiency Level(s)		HSS/HSE	HSS/HSE	HSS/HSE	HSS	HSS/HSE	HSS	HSS/HSE	HSS	HSS/HSE	HSS	HSS/HSE	HSS
Heating capacity (1)													
Gross heating Capacity (1)	(kW)	387	449	533	619	687	675	747	741	813	786	888	
Condenser													
Type		Stainless steel Copper Brazed plate Heat exchanger											
Circuit 1 BPHE		B56N-W 112pl	B56N-W 112pl	B56N-W 112pl	B56N-W 112pl	B56N-W 176pl	B56N-W 176pl	B56N-W 176pl	B56N-W 176pl	B56N-W 176pl	B56N-W 176pl	B56N-W 176pl	
Circuit 2 BPHE		B56N-W 112pl	B56N-W 112pl	B56N-W 112pl	B56N-W 112pl	B56N-W 176pl	B56N-W 176pl	B56N-W 176pl	B56N-W 176pl	B56N-W 176pl	B56N-W 176pl	B56N-W 176pl	
Nominal water connection size (Grooved coupling)	(in) - (mm)	4" - 100mm	4" - 100mm	4" - 100mm	4" - 100mm	5" - 125mm	5" - 125mm	5" - 125mm	5" - 125mm	5" - 125mm	5" - 125mm	5" - 125mm	
Water content volume (THR Full)	(l)	95.0	95.0	95.0	95.0	128.0	128.0	128.0	128.0	128.0	128.0	128.0	
Water Content Volume (THR only)	(l)	33.0	33.0	33.0	33.0	52.0	52.0	52.0	52.0	52.0	52.0	52.0	
Antifreeze Heater	(W)	900	900	900	900	900	900	900	900	900	900	900	
BPHE heaters	(W)	132	132	132	132	132	132	132	132	132	132	132	

THR		RTAF 205	RTAF 245 (2)	RTAF 250	RTAF 280	RTAF 310	RTAF 350	RTAF 380	RTAF 410	RTAF 450
Efficiency Level(s)		HSS/HSE	HSS	HSS/HSE	HSS/HSE	HSS/HSE	HSS/HSE	HSS/HSE	HSS/HSE	HSE
Heating capacity (1)										
Gross heating Capacity (1)	(kW)	856	1055	1035	1152	1283	1444	1582	1714	1907
Condenser										
Type		Stainless steel Copper Brazed plate Heat exchanger								
Circuit 1 BPHE		B56N-W 176pl	B56N-W 176pl	B427L 318pl	B427L 318pl	B427L 318pl	B427L 318pl	B427L 318pl	B427L 318pl	B427L 318pl
Circuit 2 BPHE		B56N-W 176pl	B56N-W 176pl	B56N-W 176pl	B56N-W 176pl	B56N-W 176pl	B427L 318pl	B427L 318pl	B427L 318pl	B427L 318pl
Nominal water connection size (Grooved coupling)	(in) - (mm)	5" - 125mm	5" - 125mm	6" - 150mm	6" - 150mm	6" - 150mm	6" - 150mm	6" - 150mm	6" - 150mm	6" - 150mm
Water content volume (THR Full)	(l)	128.0	128.0	200	200	200	230	230	230	230
Water Content Volume (THR only)	(l)	52.0	52.0	91	91	91	129	129	129	129
Antifreeze Heater	(W)	900	900	900	900	900	900	900	900	900
BPHE heaters	(W)	132	132	165	165	165	200	200	200	200

(1) Indicative performance at Evaporator water temperature : 12°C / 7°C- Condenser air temperature 35°C- Condenser water temperature 40°C/45°C . For accurate value refer to OWU.

(2) Data may vary according to compressor selection for a given tonnage.

Total Heat Recovery

THR General data

Table 39 – General Data Total Heat Recovery (THR) RTAF with Fix Speed Compressor - R1234ze

THR		RTAF 090	RTAF 100	RTAF 110	RTAF 120	RTAF 130	RTAF 145	RTAF 155	RTAF 185
Efficiency Level(s)		SE/HE/XE	SE/HE/XE	SE/HE/XE	SE/HE/XE	SE/HE/XE	SE/HE/XE	SE/HE/XE	SE/HE/XE
Heating capacity									
Gross heating Capacity (1)	(kW)	379	415	452	486	522	573	635	742
Condenser									
Type		Stainless steel Copper Brazed plate Heat exchanger							
Circuit 1 BPHE		B56N-W 112pl	B56N-W 112pl	B56N-W 112pl	B56N-W 112pl	B56N-W 112pl	B56N-W 112pl	B56N-W 176pl	B56N-W 176pl
Circuit 2 BPHE		B56N-W 112pl	B56N-W 112pl	B56N-W 112pl	B56N-W 112pl	B56N-W 112pl	B56N-W 112pl	B56N-W 176pl	B56N-W 176pl
Nominal water connection size (Grooved coupling)	(in) - (mm)	4" - 100mm	4" - 100mm	4" - 100mm	4" - 100mm	4" - 100mm	4" - 100mm	5" - 125mm	5" - 125mm
Water content volume	(l)	95.0	95.0	95.0	95.0	95.0	95.0	128.0	128.0
Antifreeze Heater	(W)	900.0	900.0	900.0	900.0	900.0	900.0	900.0	900.0
BPHE heaters	(W)	132.0	132.0	132.0	132.0	132.0	132.0	132.0	132.0

THR		RTAF 210	RTAF 230	RTAF 265	RTAF 285	RTAF 305	RTAF 340
Efficiency Level(s)		SE/HE/XE	SE/HE/XE	SE/HE/XE	SE/HE/XE	SE/HE/XE	SE/HE/XE
Heating capacity (1)							
Gross heating Capacity	(kW)	845	948	1105	1163	1268	1484
Condenser - Water Cooled (THR)							
Type		Stainless steel Copper Brazed Plates Heat Exchanger					
Circuit 1 BPHE		B427L 318pl	B427L 318pl	B427L 318pl	B427L 318pl	B427L 318pl	B427L 318pl
Circuit 2 BPHE		B56N-W 176pl	B56N-W 176pl	B56N-W 176pl	B427L 318pl	B427L 318pl	B427L 318pl
Nominal water connection size (Grooved coupling)	(in) - (mm)	6" - 150mm	6" - 150mm	6" - 150mm	6" - 150mm	6" - 150mm	6" - 150mm
Water content volume	(l)	200	200	200	230	230	230
Antifreeze Heater	(W)	900	900	900	900	900	900
BPHE heaters	(W)	165	165	165	200	200	200

THR General data

Table 40 – General Data Total Heat Recovery (THR) RTAF with Variable Speed Compressor - R1234ze

THR		RTAF 090	RTAF 100	RTAF 110	RTAF 120	RTAF 130	RTAF 145	RTAF 155	RTAF 185	RTAF 200	RTAF 225	RTAF 101
Efficiency Level(s)		HSS/ HSE	HSS/ HSE	HSS/ HSE	HSS/ HSE	HSS/ HSE	HSS/ HSE	HSS/ HSE	HSS/ HSE	HSS/ HSE	HSS/ HSE	HSS/ HSE
Heating capacity (1)												
Gross heating Capacity	(kW)	377	415	452	488	525	577	643	746	746	1035	1034
Condenser												
Type		Stainless steel Copper Brazed plate Heat exchanger										
Circuit 1 BPHE		B56N-W 112pl	B56N-W 112pl	B56N-W 112pl	B56N-W 112pl	B56N-W 112pl	B56N-W 112pl	B56N-W 176pl	B56N-W 176pl	B56N-W 176pl	B56N-W 176pl	B56N-W 176pl
Circuit 2 BPHE		B56N-W 112pl	B56N-W 112pl	B56N-W 112pl	B56N-W 112pl	B56N-W 112pl	B56N-W 112pl	B56N-W 176pl	B56N-W 176pl	B56N-W 176pl	B56N-W 176pl	B56N-W 176pl
Nominal water connection size (Grooved coupling)	(in) - (mm)	4" - 100mm	4" - 100mm	4" - 100mm	4" - 100mm	4" - 100mm	4" - 100mm	5" - 125mm	5" - 125mm	5" - 125mm	5" - 125mm	5" - 125mm
Water content volume	(l)	95.0	95.0	95.0	95.0	95.0	95.0	128.0	128.0	128.0	128.0	128.0
Antifreeze Heater	(W)	900.0	900.0	900.0	900.0	900.0	900.0	900.0	900.0	900.0	900.0	900.0
BPHE heaters	(W)	132.0	132.0	132.0	132.0	132.0	132.0	132.0	132.0	132.0	132.0	132.0

THR		RTAF 210	RTAF 230	RTAF 265	RTAF 275	RTAF 285	RTAF 300	RTAF 305	RTAF 340	RTAF 385	RTAF 405	RTAF 470
Efficiency Level(s)		HSS/ HSE	HSS/ HSE	HSS/ HSE	HSS/ HSE	HSS/ HSE	HSS/ HSE	HSS/ HSE	HSS/ HSE	HSS/ HSE	HSS/ HSE	HSS/ HSE
Heating capacity (1)												
Gross heating Capacity	(kW)	848	955	1107	1165	1240	1291	1394	1485	1622	1783	2139
Condenser - Water Cooled (THR)												
Type		Stainless steel Copper Brazed plate Heat exchanger										
Circuit 1 BPHE		B427L 318pl	B427L 318pl	B427L 318pl	B427L 318pl	B427L 318pl	B427L 318pl	B427L 318pl	B427L 318pl	B427L 318pl	B427L 318pl	B427L 318pl
Circuit 2 BPHE		B56N-W 176pl	B56N-W 176pl	B56N-W 176pl	B56N-W 176pl	B427L 318pl	B56N-W 176pl	B427L 318pl	B427L 318pl	B427L 318pl	B427L 318pl	B427L 318pl
Nominal water connection size (Grooved coupling)	(in) - (mm)	6" - 150mm	6" - 150mm	6" - 150mm	6" - 150mm	6" - 150mm	6" - 150mm	6" - 150mm	6" - 150mm	6" - 150mm	6" - 150mm	6" - 150mm
Water content volume	(l)	200	200	200	200	230	200	230	230	230	230	230
Antifreeze Heater	(W)	900	900	900	900	900	900	900	900	900	900	900
BPHE heaters	(W)	165	165	165	165	200	165	200	200	200	200	200

(1) Indicative performance at Evaporator water temperature : 12°C / 7°C- Condenser air temperature 35°C- Condenser water temperature 40°C/45°C . For accurate value refer to OWU.

(2) Data may vary according to compressor selection for a given tonnage.

Total Heat Recovery

2 versions:

- Digit 23=T Full equipment (BPHE + Water lines + 3-ways water valve + heaters + flow-switch + insulation)
- Digit 23=V Naked (BPHE + insulation)
- This type of unit remains an air-cooled chiller before modification into a Total Heat Recovery unit. Start up and Shut down are always carried out in chiller mode. (freeze protection by standard tank)
- All Free cooling options exclude Total Heat Recovery and not developed for high ambient.
- Operating map : Maximum water temperature depends on compressor load and operating conditions. It may vary from 30°C to 61°C. For details performance consult Order Write Up.
- Flow-switch : The flow-switch is fitted on water line to monitor a too low water flow through the Total Heat Recovery heat Exchanger.
- Heaters are placed on water piping to heat the whole Total Heat Recovery system (water piping, water 3-ways valve, BPHE).
- To protect the Total Heat Recovery circuit during winter or off mode, circuit must be filled by glycol with at least a concentration of 35%.
- Introduction of an expansion tank and safety valve is recommended on the water circuit.
- The water valve is a safety device to allow a limited water flow below 25°C of THR entering water. Above 25°C, the 3-ways water valve is full open.

Total Heat Recovery

Figure 19 – THR pressure drop - Heat Exchanger Only

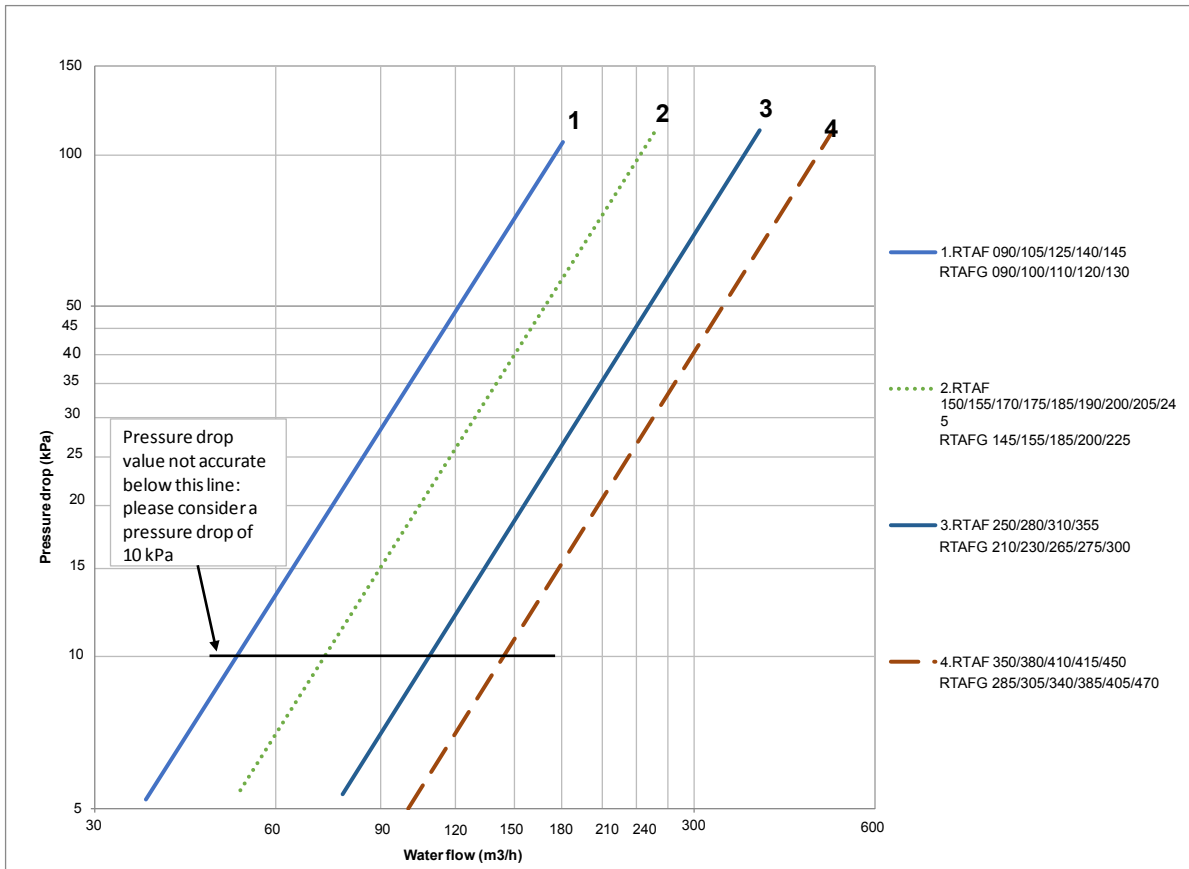
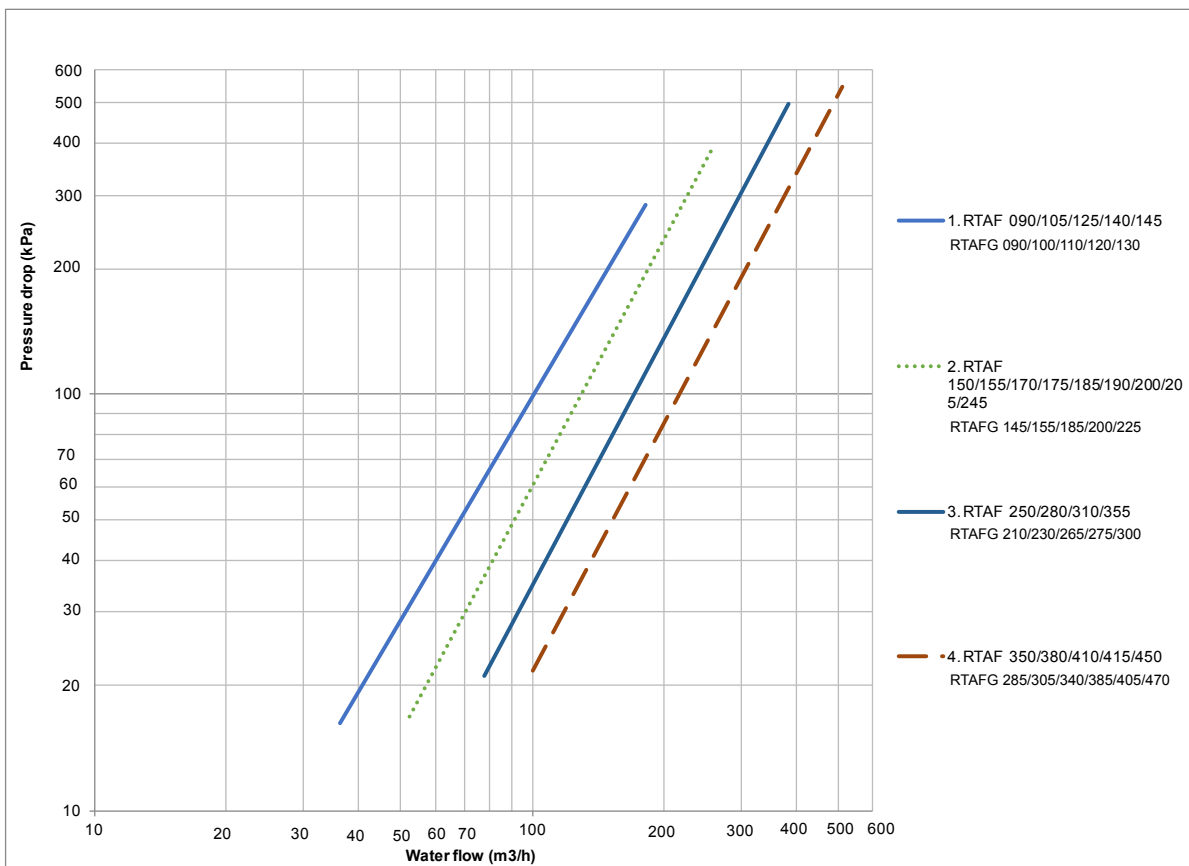

Figure 20 – THR pressure drop - BPHE + 3 Ways valve + Water Piping





Optional Free-Cooling

Table 41a – General data for free cooling option sizes 090- 205 - R134a

		RTAF 090	RTAF 105	RTAF 125	RTAF 145	RTAF 155	RTAF 175	RTAF 185	RTAF 190	RTAF 200	RTAF 205
General											
Heat-Exchanger Type		Aluminum heat exchanger									
Fan type (1) (SE-SN/HE-SN/HE-LN)		AC	AC	AC	AC	AC	AC	AC	AC	AC	AC
Power per Motor	(kW)	1.79	1.79	1.79	1.79	1.79	1.78	1.76	1.79	1.79	1.78
Motor RPM	(rpm)	932	932	932	932	932	932	932	932	932	932
Fan type (2) SE-LN/XE-SN/XE-LN/HSS-SN/ HSS-LN/HSE-SN/HSE-LN		EC	EC	EC	EC	EC	EC	EC	EC	EC	EC
Power per Motor	(kW)	1.47	1.47	1.47	1.47	1.47	1.47	1.47	1.47	1.47	1.47
Motor RPM	(rpm)	910	910	910	910	910	910	910	910	910	910
Fan type (3) SE-XLN/XE-XLN/HSS-SN/ HSS-XLN/HSE-XLN		ECXLN	ECXLN	ECXLN	ECXLN	ECXLN	ECXLN	ECXLN	ECXLN	ECXLN	ECXLN
Power per Motor	(kW)	1.21	1.21	1.21	1.21	1.21	1.21	1.21	1.21	1.21	1.21
Motor RPM	(rpm)	860	860	860	860	860	860	860	860	860	860
Input water connection size (Grooved coupling)	(in) - (DN)	4" - 100	4" - 100	5" - 125	5" - 125	5" - 125	6" - 150	6" - 168.3	6" - 150	6" - 168.3	6" - 150
Output water connection size (Grooved coupling)	(in) - (DN)	4" - 100	4" - 100	5" - 125	5" - 125	5" - 125	6" - 150	6" - 168.3	6" - 150	6" - 168.3	6" - 150
Direct Free Cooling Option (4)											
Total Free Cooling Option											
Coils quantity SE-SN/SE-LN/SE-XLN/ HSS-SN/HSS-LN/HSS-XLN (5)	#	7	7	7	9	9	9	9	11	11	11
Coils quantity HE-SN/HE-LN/XE-SN/XE-LN/ XE-XLN/HSE-SN/HSE-LN/HSE-XLN (6)	#	9	9	9	11	11	11	/	13	/	13
Summer nominal water flow	(L/s)	15.8	18.4	21.4	25.6	27.5	30.4	27.5	33.4	35.0	36.0
Summer unit pressure drop	(kPa)	74	88	100	82	90	95	96	115	104	117
Winter unit pressure drop	(kPa)	143	165	187	182	197	204	217	204	217	209
Free Cooling weight (5)	(kg)	502	502	502	648	653	694	584	782	584.0	779
Additional water content (without Evap.) (5)	(L)	183	183	185	231	231	262	216	301	216.3	301
Free Cooling weight (6)	(kg)	607	607	655	742	742	782	/	862	/	869
Additional water content (without Evap.) (6)	(L)	223	223	231	270	270	301	/	338	/	338
Partial Free Cooling type											
Coils quantity	#	4	4	4	6	6	6	6	6	6	6
Summer nominal water flow	(L/s)	16.1	18.6	21.6	26.0	28.0	30.8	26.3	33.8	35.7	36.6
Summer unit pressure drop	(kPa)	75	89	76	85	92	97	93	117	108	119
Winter unit pressure drop	(kPa)	132	150	165	149	159	167	162	191	162	196
Additional Free Cooling weight (without water) (5)	(kg)	393	393	395	548	548	584	584	580	584	580
Additional water content (without Evap.) (5)	(L)	134	134	135	183	183	216	216	214	216	214
Additional Free Cooling weight (without water) (6)	(kg)	397	397	435	540	544	580	/	577	/	577
Additional water content (without Evap.) (6)	(L)	137	137	140	181	181	214	/	218	/	218
Glycol Free Option											
Total Free Cooling type											
Coils quantity (5)	#	7	7	7	9	9	9	9	11	9	11
Coils quantity (6)	#	9	9	9	11	11	11	/	13	/	13
Summer nominal water flow	(L/s)	14.8	17.2	20.1	23.9	25.7	28.3	30.2	31.1	32.5	33.6
Summer & Winter unit pressure drop	(kPa)	63.9	74.5	79.9	77.9	84.4	89.3	NA	90.4	NA	90.1
Glycol Pump Max Power input (kW)	(kW)	5.5	5.5	11	11	11	11	11	11	11	11
Glycol Pump Max Amps @ 110 V	(A)	10.2	10.2	20.5	20.5	20.5	20.5	20.5	20.5	20.5	20.5
Freeze protection - Max Power input	kW	0.72	0.72	0.72	0.9	0.9	0.9	0.9	0.9	1.02	1.02
Freeze protection - Max Amps	A	1.8	1.8	1.8	2.25	2.25	2.25	2.25	2.25	2.55	2.55
Additional Free Cooling weight (without water) (5)	(kg)	1032	1032	1069	1320	1307	1326	1326	1467	1326	1473
Additional Free Cooling weight (without water) (6)	(kg)	1125	1125	1227	1395	1395	1414	/	1561	/	1561
Additional water content (without Evap.) (5)	(L)	69	69	88	109	109	111	111	126	111	126
Additional water content (without Evap.) (6)	(L)	69	69	88	109	109	111	/	126	/	126
Glycol content (5)	(L)	238	238	238	304	304	306	306	360	306	360
Glycol content (6)	(L)	279	279	283	342	342	345	/	396	/	396
Additional baseframe length (5)	(m)	/	/	/	/	/	/	/	/	/	/
Additional baseframe length (6)	(m)	/	/	/	/	/	/	/	/	/	/

Optional Free-Cooling

Table 41a – General data for free cooling option sizes 090- 205 - R134a (continued)

		RTAF 090	RTAF 105	RTAF 125	RTAF 145	RTAF 155	RTAF 175	RTAF 185	RTAF 190	RTAF 200	RTAF 205
Partial Free Cooling type											
Coils quantity (5)	#	4	4	4	6	6	6	6	6	6	6
Coils quantity (6)	#	4	4	4	6	6	6	/	6	/	6
Summer nominal water flow	(L/s)	15.1	17.5	20.3	24.3	26.1	28.7	30.7	31.5	33.2	34.2
Summer & Winter unit pressure drop	(kPa)	51	57	58	82	88	65	NA	77	NA	75
Glycol Pump Max Power input (kW)	(kW)	4.0	4.0	4.0	4.0	4.0	5.5	5.5	5.5	5.5	5.5
Glycol Pump Max Amps @ 110 V	(A)	7.8	7.8	7.8	7.8	7.8	10.2	10.2	10.2	10.2	10.2
Freeze protection - Max Power input	kW	0.66	0.66	0.66	0.66	0.66	0.72	0.72	0.72	0.72	0.72
Freeze protection - Max Amps	A	1.65	1.65	1.65	1.65	1.65	1.80	1.80	1.80	1.80	1.80
Additional Free Cooling weight (without water) (5)	(kg)	777	777	789	928	928	1027	1027	1023	1027	1023
Additional Free Cooling weight (without water) (6)	(kg)	785	785	801	918	924	1023	/	1019	/	1019
Additional water content (without Evap.) (5)	(L)	54	54	73	73	73	90	90	90	90	90
Additional water content (without Evap.) (6)	(L)	785	785	801	918	924	1023	/	1019	/	1019
Glycol content (5)	(L)	175	175	173	219	219	239	239	238	239	238
Glycol content (6)	(L)	279	279	283	342	342	345	/	396	/	396
Additional baseframe length (5)	(m)	1.125	1.125	1.125	/	/	/	/	/	/	/
Additional baseframe length (6)	(m)	/	/	/	/	/	/	/	/	/	/

(1) SE-SN/HE-SN/HE-LN

(2) SE-LN/XE-SN/XE-LN/HSS-SN/HSS-LN/HSE-SN/HSE-LN

(3) SE-XLN/XE-XLN/HSS-SN/HSS-XLN/HSE-XLN

(4) Max Speed - range is 60% to 100% of max speed

(5) SE-SN/SE-LN/SE-XLN/HSS-SN/HSS-LN/HSS-XLN

(6) HE-SN/HE-LN/XE-SN/XE-LN/XE-XLN/HSE-SN/HSE-LN/HSE-XLN



Optional Free-Cooling

Table 41b – General data for free cooling option sizes 250- 410 - R134a

		RTAF 250 (4)	RTAF 280	RTAF 310	RTAF 350	RTAF 380	RTAF 410
General							
Heat-Exchanger Type		Aluminum heat exchanger					
Fan type (1) (SE-SN/HE-SN/HE-LN)		AC	AC	AC	AC	AC	AC
Power per Motor	(kW)	1.78	1.79	1.78	1.79	1.79	1.79
Motor RPM	(rpm)	932	932	932	932	932	932
Fan type (2) SE-LN/XE-SN/XE-LN/HSS-SN/HSS-LN/HSE-SN/HSE-LN		EC	EC	EC	EC	EC	EC
Power per Motor	(kW)	1.47	1.47	1.47	1.47	1.47	1.47
Motor RPM	(rpm)	910	910	910	910	910	910
Fan type (3) SE-XLN/XE-XLN/HSS-SN/HSS-XLN/HSE-XLN		ECXLN	ECXLN	ECXLN	ECXLN	ECXLN	ECXLN
Power per Motor	(kW)	1.21	1.21	1.21	1.21	1.21	1.21
Motor RPM	(rpm)	860	860	860	860	860	860
Input water connection size (Grooved coupling)	(in) - (DN)	6" - 150	6" - 150	6" - 150	8" - 200	8" - 200	8" - 200
Output water connection size (Grooved coupling)	(in) - (DN)	6" - 150	6" - 150	6" - 150	8" - 200	8" - 200	8" - 200
Direct Free Cooling Option							
Total Free Cooling Option							
Coils quantity SE-SN/SE-LN/SE-XLN/HSS-SN/HSS-LN/HSS-XLN (6)	#	14	16	16	18	20	22
Coils quantity HE-SN/HE-LN/XE-SN/XE-LN/XE-XLN/HSE-SN/HSE-LN/HSE-XLN (7)	#	16	18	20	22	24	24
Summer nominal water flow	(L/s)	42.0	47.6	52.7	58.6	64.8	70.1
Summer unit pressure drop	(kPa)	93	106	118	98	109	119
Winter unit pressure drop	(kPa)	207	215	229	205	210	219
Free Cooling weight (6)	(kg)	1090	1239	1373	1425	1522	1629
Additional water content (without Evap.) (6)	(L)	602	663	663	765	829	892
Free Cooling weight (7)	(kg)	1239	1350	1596	1627	1757	1760
Additional water content (without Evap.) (7)	(L)	663	726	787	892	956	956
Partial Free Cooling type							
Coils quantity	#	8	8	10	10	10	12
Summer nominal water flow	(L/s)	42.5	48.0	53.3	59.9	65.9	71.5
Summer unit pressure drop	(kPa)	94.2	107.2	119.5	101.0	111.9	122.9
Winter unit pressure drop	(kPa)	180.5	201.7	184.4	204.6	224.3	209.1
Additional Free Cooling weight (without water) (6)	(kg)	786	807	1084	993	1049	1086
Additional water content (without Evap.) (6)	(L)	413	416	479	518	532	578
Additional Free Cooling weight (without water) (7)	(kg)	807	804	1081	993	1049	1112
Additional water content (without Evap.) (7)	(L)	416	413	476	518	532	582
Free Cooling Glycol Free Option							
Total Free Cooling type							
Coils quantity (6)	#	N/A	16	16	18	20	22
Coils quantity (7)	#	16	18	20	22	24	24
Summer nominal water flow	(L/s)	39.7	44.4	49.2	54.7	60.5	65.4
Summer & Winter unit pressure drop	(kPa)	77	84	92	101	98	107
Glycol Pump Max Power input (kW)	(kW)	22	22	22	22	22	22
Glycol Pump Max Amps @ 110 V	(A)	38	38	38	38	38	38
Freeze protection - Max Power input	kW	1.8	1.8	1.8	1.8	1.8	2.04
Freeze protection - Max Amps	A	4.5	4.5	4.5	4.5	4.5	5.1
Additional Free Cooling weight (without water) (6)	(kg)	N/A	2354	2354	2541	2752	2869
Additional Free Cooling weight (without water) (7)	(kg)	2354	2475	2595	2762	3009	3013
Additional water content (without Evap.) (6)	(L)	N/A	245	245	281	311	311
Additional water content (without Evap.) (7)	(L)	245	245	245	281	311	311
Glycol content (6)	(L)	N/A	765	765	825	918	982
Glycol content (7)	(L)	765	828	888	952	1045	1045
Additional baseframe length (6)	(m)	N/A	1.125	1.125	1.125	1.125	1.125
Additional baseframe length (7)	(m)	1.125	1.125	/	1.125	/	/
Partial Free Cooling type							
Coils quantity (6)	#	N/A	8	10	10	10	12
Coils quantity (7)	#	8	8	10	10	10	12

Optional Free-Cooling

Table 41b – General data for free cooling option sizes 250- 410- R134a (continued)

		RTAF 250 (4)	RTAF 280	RTAF 310	RTAF 350	RTAF 380	RTAF 410
Summer nominal water flow	(L/s)	40.2	44.8	49.8	55.9	61.6	66.8
Summer & Winter unit pressure drop	(kPa)	96	78	85	80	87	94
Glycol Pump Max Power input (kW)	(kW)	11.0	11.0	11.0	11.0	11.0	11.0
Glycol Pump Max Amps @ 110 V	(A)	20.5	20.5	20.5	20.5	20.5	20.5
Freeze protection - Max Power input	kW	1.32	1.32	1.32	1.44	1.44	1.44
Freeze protection - Max Amps	A	3.30	3.30	3.30	3.60	3.60	3.60
Additional Free Cooling weight (without water) (6)	(kg)	N/A	1422	1551	1675	1736	1775
Additional Free Cooling weight (without water) (7)	(kg)	1348	1419	1547	1675	1736	1803
Additional water content (without Evap.) (6)	(L)	N/A	132	132	182	182	182
Additional water content (without Evap.) (7)	(L)	111	132	132	182	182	182
Glycol content (6)	(L)	N/A	496	560	575	589	635
Glycol content (7)	(L)	475	493	556	575	589	639
Additional baseframe length (6)	(m)	N/A	1.125	1.125	1.125	1.125	1.125
Additional baseframe length (7)	(m)	1.125	1.125	/	1.125	/	/

- (1) SE-SN/HE-SN/HE-LN
- (2) SE-LN/XE-SN/XE-LN/HSS-SN/HSS-LN/HSE-SN/HSE-LN
- (3) SE-XLN/XE-XLN/HSS-SN/HSS-XLN/HSE-XLN
- (4) Option is not define for size 250 option SE-SN/SE-LN/SE-XLN/HSS-LN/HSS-XLN
- (5) Max Speed - range is 60% to 100% of max speed
- (6) SE-SN/SE-LN/SE-XLN/HSS-SN/HSS-LN/HSS-XLN
- (7) HE-SN/HE-LN/XE-SN/XE-LN/XE-XLN/HSE-SN/HSE-LN/HSE-XLN



Optional Free-Cooling

Chiller integrated free-cooling operation mode

The power of chiller integrated free-cooling relies on the chiller control to maximize the use of free-cooling when outdoor temperatures are favorable. The choice between compressor refrigeration and Free-Cooling refrigeration will be made and activated depending on three temperature measurements:

- The ambient air temperature
- The evaporator entering and leaving temperature
- The chilled water set point

Free-cooling coils are fit in series with the evaporator, and a set of water regulation valves allows the coils to be by-passed when they are no longer needed due to outdoor temperatures which are favorable for free-cooling.

Three operating modes can be differentiated:

1. Summer operation or Compressor refrigeration mode

In this operation mode, ambient temperature is higher than the temperature of the fluid entering the evaporator. Free-cooling is not activated, compressors are running, and control is done in function of the fan/compressor logic of operation.

2. Mid-season operation or combined refrigeration + Free-cooling mode

In this operation mode, free-cooling will be enabled whenever the outdoor temperature is below the evaporator entering water temperature. The operating logic is described below. The free-cooling system operates combined with the mechanical compressor refrigeration. Most of the time, free-cooling will only partially cover the required cooling duty. In other words, mechanical refrigeration will complete what has already been delivered by free-cooling.

3. Winter operation or Full free-cooling mode

Below a certain ambient temperature, and depending on the chilled water set point requested, the entire cooling duty is delivered by the free-cooling system. Compressors do not operate, since the free-cooling coils will be able to deliver the requested chilled water temperature. The regulation of the capacity is described in the next section. In this mode, only fans are running.

General information

The chiller integrated free-cooling system fluid based consist in a set of "Macro-channels" or "Radiators" coils, fit in the same frame than the MCHE condenser coils of the chiller refrigerant circuit. Free-cooling coils will be full aluminum, flat radiator design type, with low air pressure drop to avoid fan performances degradation.

Free-cooling coils are fit in series with the evaporator, and a set of water regulation valves ensures the system to reach the required free-cooling capacity.

Optional Free-Cooling

Figure 21 – Flow chart – Free-Cooling – Direct free cooling version

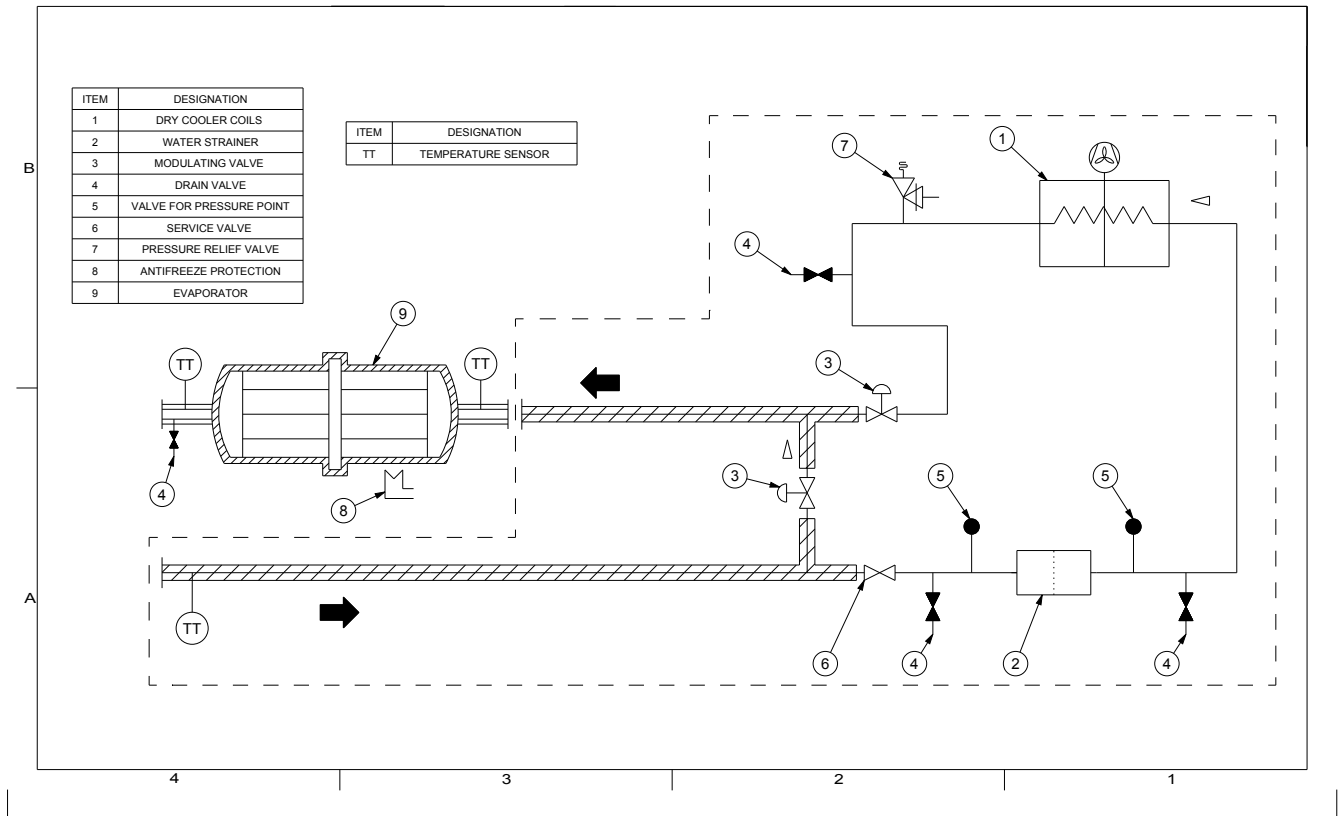

Note: glycol free cooling chilled water setpoint should be in the range of [4°C - 20°C]. Water & Glycol mixture is filled on the free cooling coils on valve item 4 (3/4").

Optional Free-Cooling

Figure 22 – Total and Partial Free-Cooling option

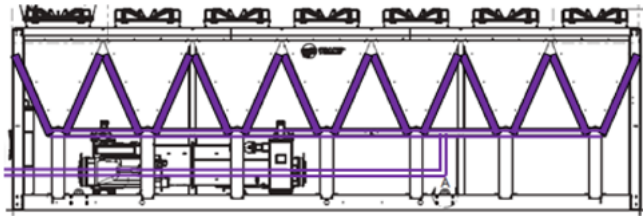

a. Total Free Cooling, Direct free cooling version

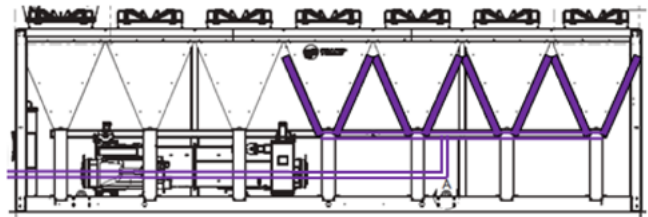

b. Partial Free Cooling, Direct free cooling version

If there is a need to get a definition for partial heat recovery coil distribution, please contact the Trane Sales office.

Free-Cooling Enabling Conditions

To get the free cooling active, condition is to have unit in active cooling mode and that Outdoor temperature low enough according to figure below.

The free cooling function is enabled when outdoor air temperature is below Active chilled water cooling set point minus FC_offset.

A hysteresis should also apply to avoid short cycling of Free Cooling enabling logic. The Free Cooling offset is an adjustable parameter to make free cooling active.

If free cooling function is enabled, free cooling becomes the 1st stage of cooling. Free cooling is the first stage to engage for cooling capacity loading and the last stage to consider in capacity unloading.

In order to maximize tandem operation of free cooling with compressor the following logic is applied:

When unit is configured in “Partial free cooling”, when free cooling reaches its full capacity and there is a call for compressor start, then the first circuit to start shall be circuit 2 (if available). This also means compressor balancing function is disabled in these conditions.

Note: UC800 will not lockout compressor below free cooling change over point, but the compressor is locked out when outdoor air is below “low ambient limit” set at -10°C. So FC will be the only source of cooling below -10°C.

Figure 23 – Free-cooling enabling conditions

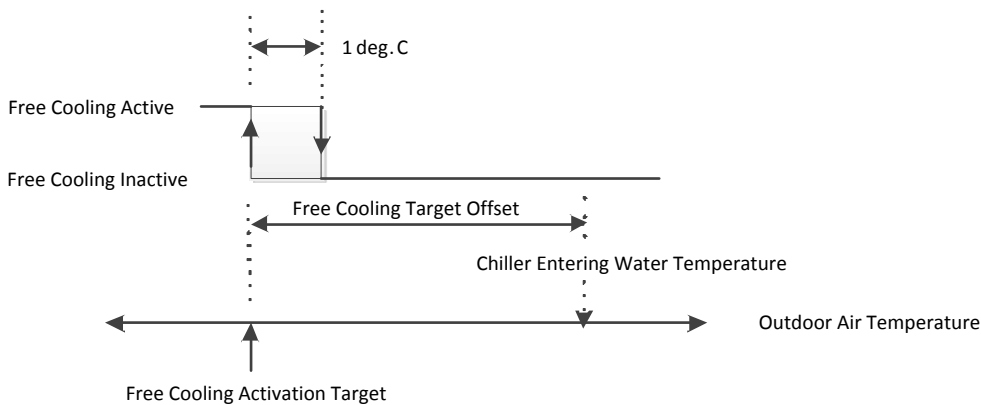

Optional Free-Cooling

Figure 24 – Flow chart - Free cooling - Glycol free version

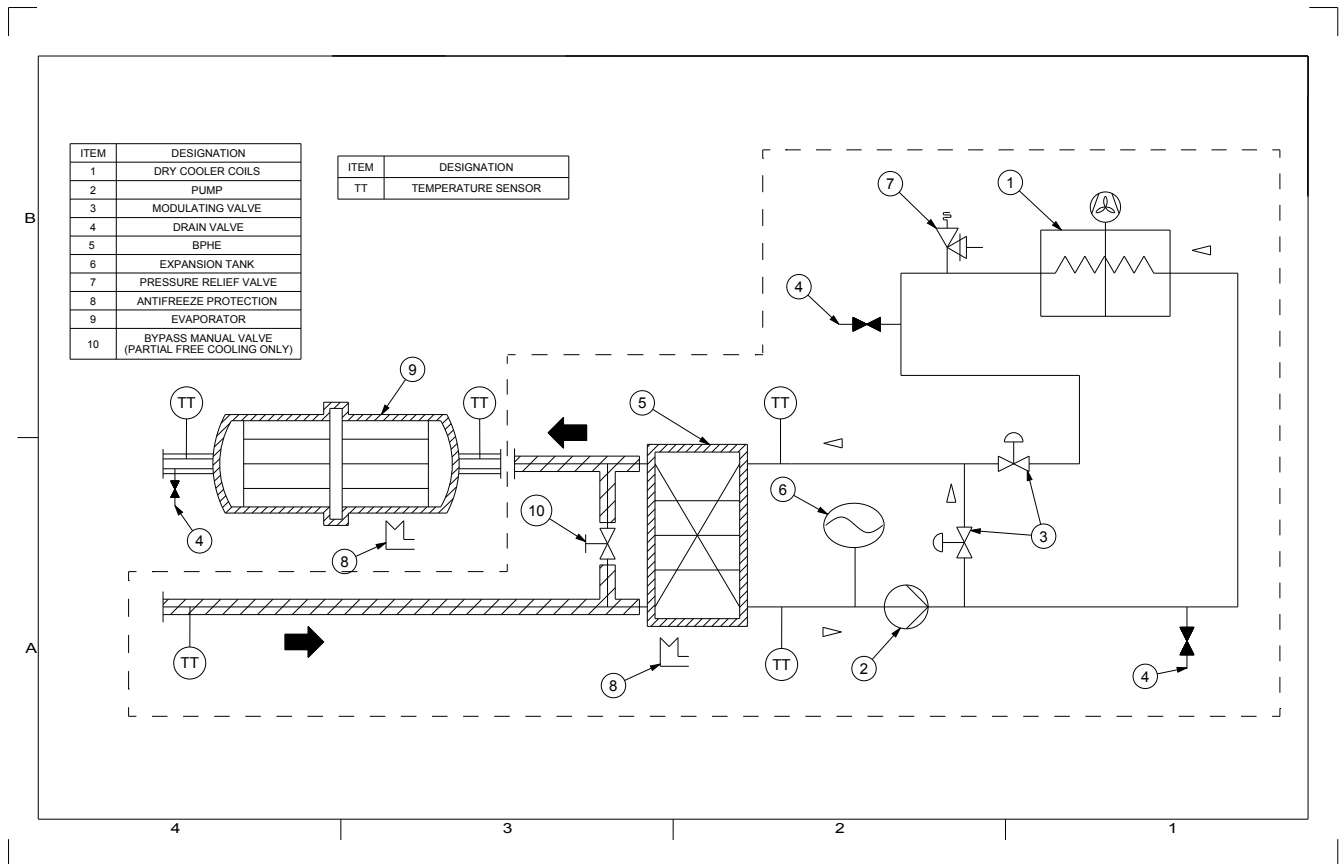

Note: glycol free cooling chilled water setpoint should be in the range of [4°C- 20° C]. Glycol is filled on the free cooling coils on valve item 4 (3/4").



Optional Free-Cooling

Note for installation

All Submittal, lifting diagram, neoprene pads positioning and wiring diagrams have been supplied with chiller order.

The maximum pressure of the Glycol side when unit is equipped with free cooling is 400 kPa for Glycol free option or 600kPa for Direct free cooling except on evaporator side for glycol free 1000 kPa Refer to unit nameplate for rated value.

Pump operation with Glycol free : it is requested to have a minimum water side pressure of 250 kPa to avoid cavitation.

Glycol free option : To avoid component damage, a filter (1 mm mesh) must be supplied by the customer and installed at the unit inlet.

Unit is shipped without glycol content on the free cooling circuit.

Free cooling loop venting must be performed by using Manual override mode to run the free cooling pump and opening free cooling and closing bypass valve.

At 10 to 20°C ambient, the expansion shall be pressurized at 250 kpa. It should be checked when glycol loop is not yet filled or glycol pressure is near zero.

All Free-cooling units must be freeze-protected with at least 30% Ethylene Glycol in the cooling loop circuit which is the most convenient percentage in order to protect the unit against freezing. Upon receipt, make sure that there is no remaining test water in the free cooling circuit as it may freeze during winter periods.

Protection coverage with 30% Ethylene Glycol:

- Freezing point without burst effect = -13°C
- Freezing point with burst effect = -50°C.

Water can be trapped in BPHE and specific care must be taken to remove it completely from BPHE during off mode if drainage is the winter protection chosen.

Optional Free-Cooling

The free cooling option circuit consists of copper, carbon steel, cast iron, zinc, synthetic rubber, brass, and Aluminum AA3102, AA3003, AA4045 in addition to other materials that may be in the building loop connected to the chiller. The inhibited glycol solution should be selected at desired concentration to ensure adequate inhibitor content. It is not advised to dilute a stronger concentrate due to inhibitor dilution. Glycol fluid should be free from foreign solid particles. A maintenance schedule should be selected per the glycol manufacturer's requirements to insure adequate protection during product usage.

Notice: Equipment Damage!

Failure to follow instructions below could cause equipment damage.

DO NOT USE UNTREATED WATER. Glycol solution must be utilised with the Direct Free Cooling option. Glycol percentage should be based on freeze avoidance requirements. The glycol solution requires an inhibitor package to be carefully chosen with the aid of a qualified water treatment specialist to abate corrosion in a mixed

metal system.

The building glycol loop should not be vented to atmosphere. A closed system is required to limit oxidation potential within the loop.

Make-up water should be avoided.

Free cooler by-pass valve adjustment

For intervention on free cooler by-pass valve it is recommended to consult the valve service literature.

For every new referencing of the motor end travel, an adaptation of the motor should be done by pushing button 2.

To change the bypass percentage follows below procedure:

- No tuning is needed on free cooling valve which always stays on full opening/closure.
- For bypass valve Belimo, minimum opening can be adjusted by pushing the release button (4) and by turning handle 5 to 50% opening for instance (45°)

Operating controls and indicators

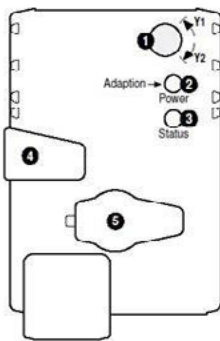

- 1** Direction of rotation switch
Switch over: Direction of rotation changes
 - 2** Push-button and LED display green
Off: No power supply or malfunction
On: In operation
Press button: Triggers angle of rotation adaptation, followed by standard mode
 - 3** Push-button and LED display yellow
Off: Standard mode
On: Adaptation or synchronising process active
Press button: No function
 - 4** Gear disengagement button
Press button: Gear disengages, motor stops, manual override possible
Release button: Gear engages, synchronisation starts, followed by standard mode
 - 5** Service plug
For connecting parameterisation and service tools
- Check power supply connection
2 Off and **3** On Possible wiring error in power supply

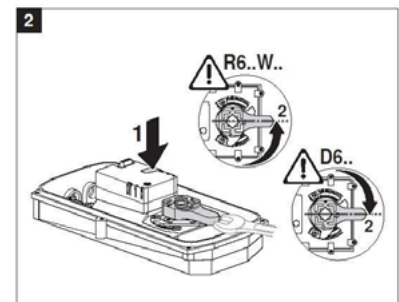

Optional Free-Cooling

With a Phillips screwdriver, move the end of travel. Fix it to always keep an opening between 100% and the minimum desired (50%) in example below.

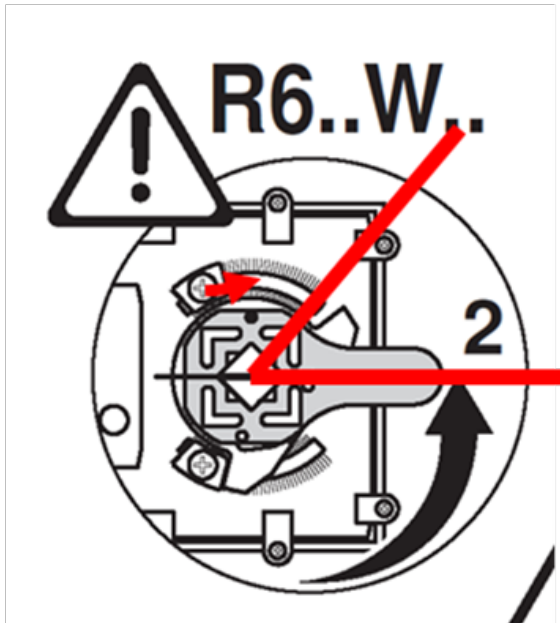

If the minimum opening is modified after the first powering, motor re-calibration is needed to validate the new operating range. When motor is powered, push green led button (2). Motor memorizes the new reference of end of travel position on its signal (2...10VDC)

Note for maintenance : Check glycol circuit pressure before free cooling operation season starts. Run glycol pump few minutes in manual override during monthly maintenance operation when free cooling is continuously OFF to avoid possible glycol cristalization. Pump Override function is located in TD7 via Button Settings-> Manual Control Settings-> Free Cooling Pump Override.

Optional Free-Cooling

Water Pressure Drops - Coils

The free cooling water pressure drops given in charts below (coil + valve) should be added to evaporator pressure drop to get full unit pressure drop.

Figure 25 – Water pressure drop - Partial Free-Cooling - Sizes 090-245

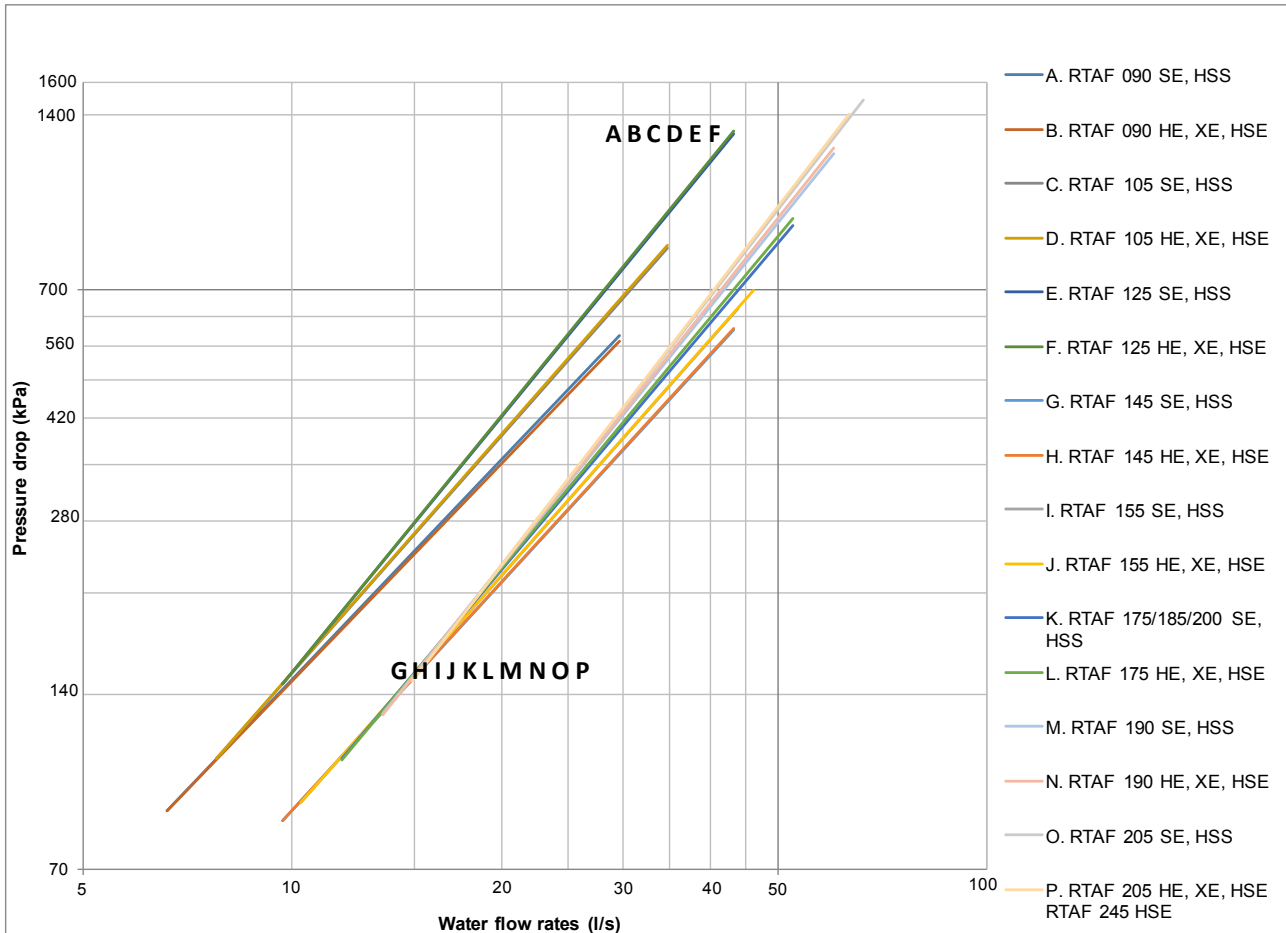

Optional Free-Cooling

Figure 26 – Water pressure drop -Partial Free-Cooling - Direct Free Cooling version - Sizes 250-410

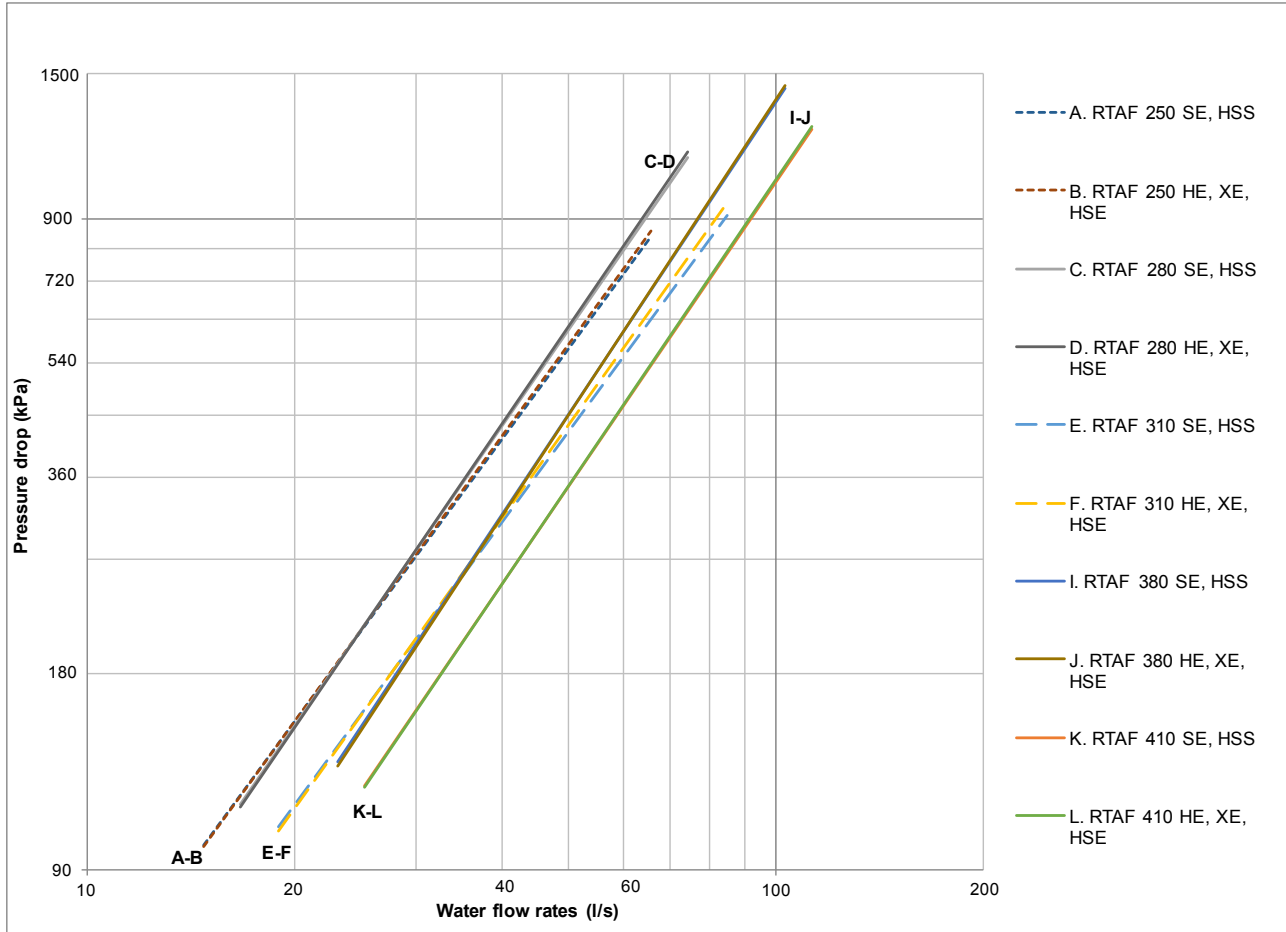

Optional Free-Cooling

Figure 27 – Water pressure drop - Total Free Cooling - Direct Free cooling version - Sizes 090-245

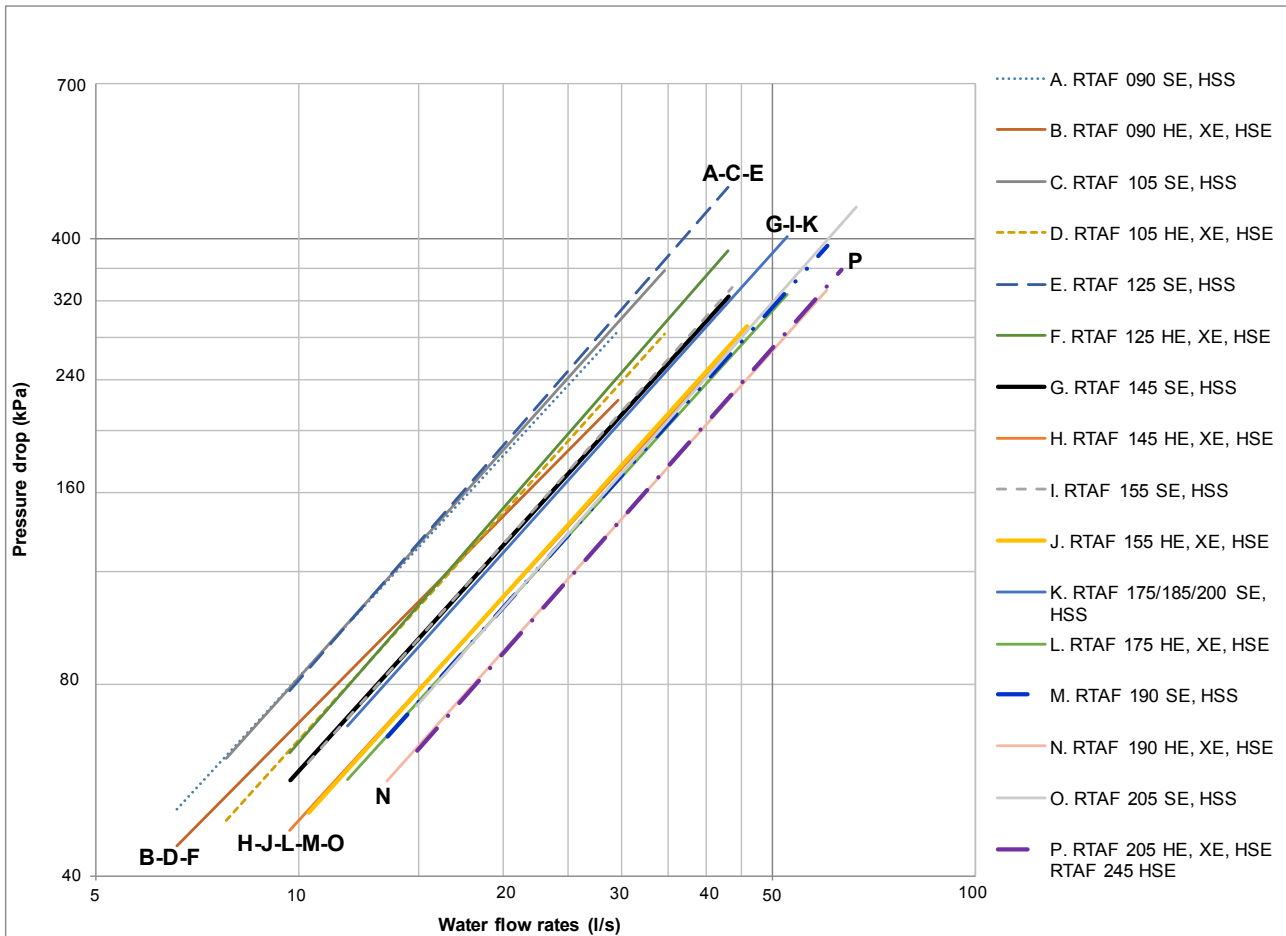

Optional Free-Cooling

Figure 28 – Water pressure drop - Total Free Cooling - Direct Free Cooling Version- Sizes 250-410

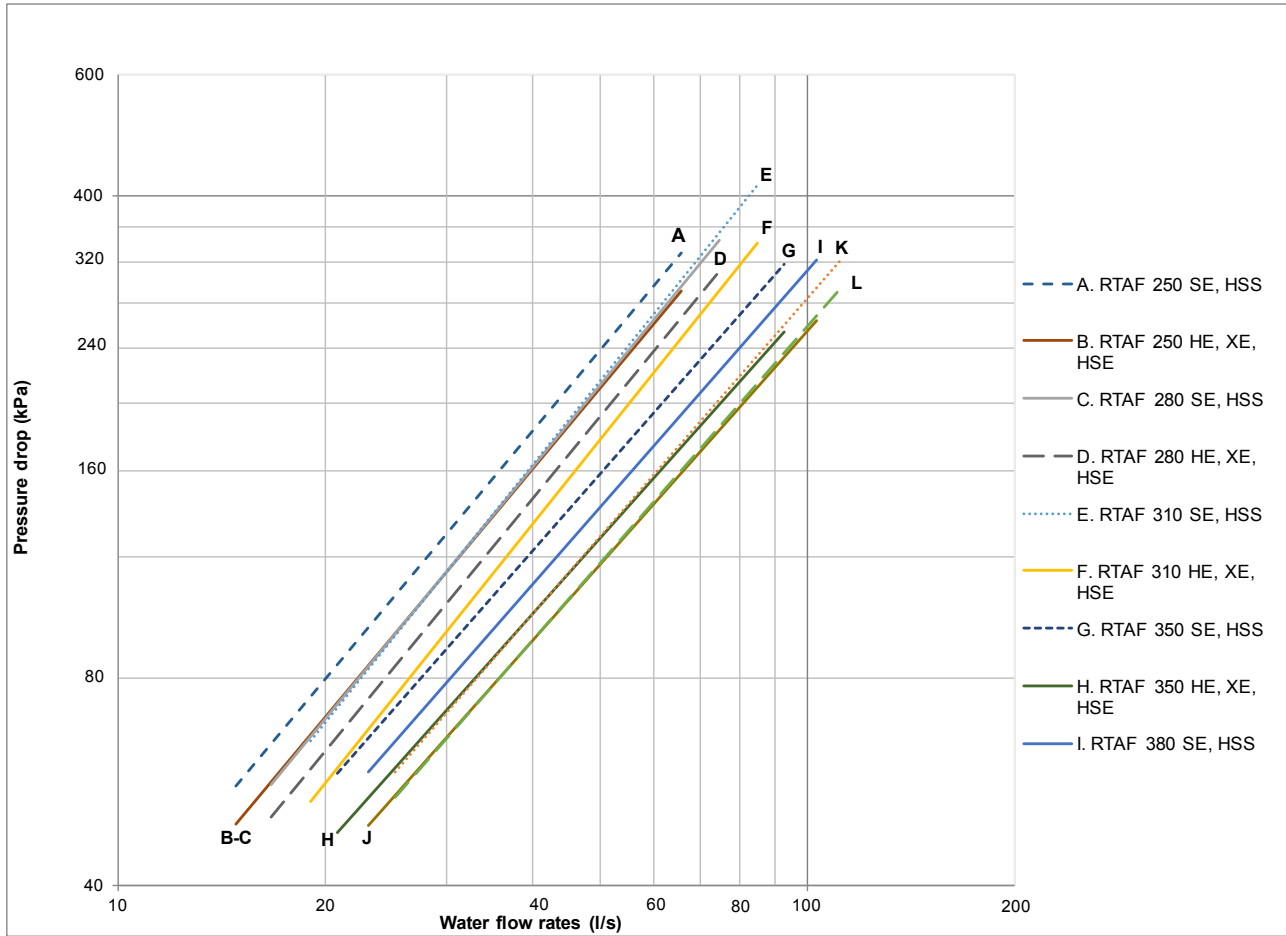

Optional Free-Cooling

Figure 29 – Water Pressure Drop - Glycol Free - Partial Free Cooling - Sizes 90-205

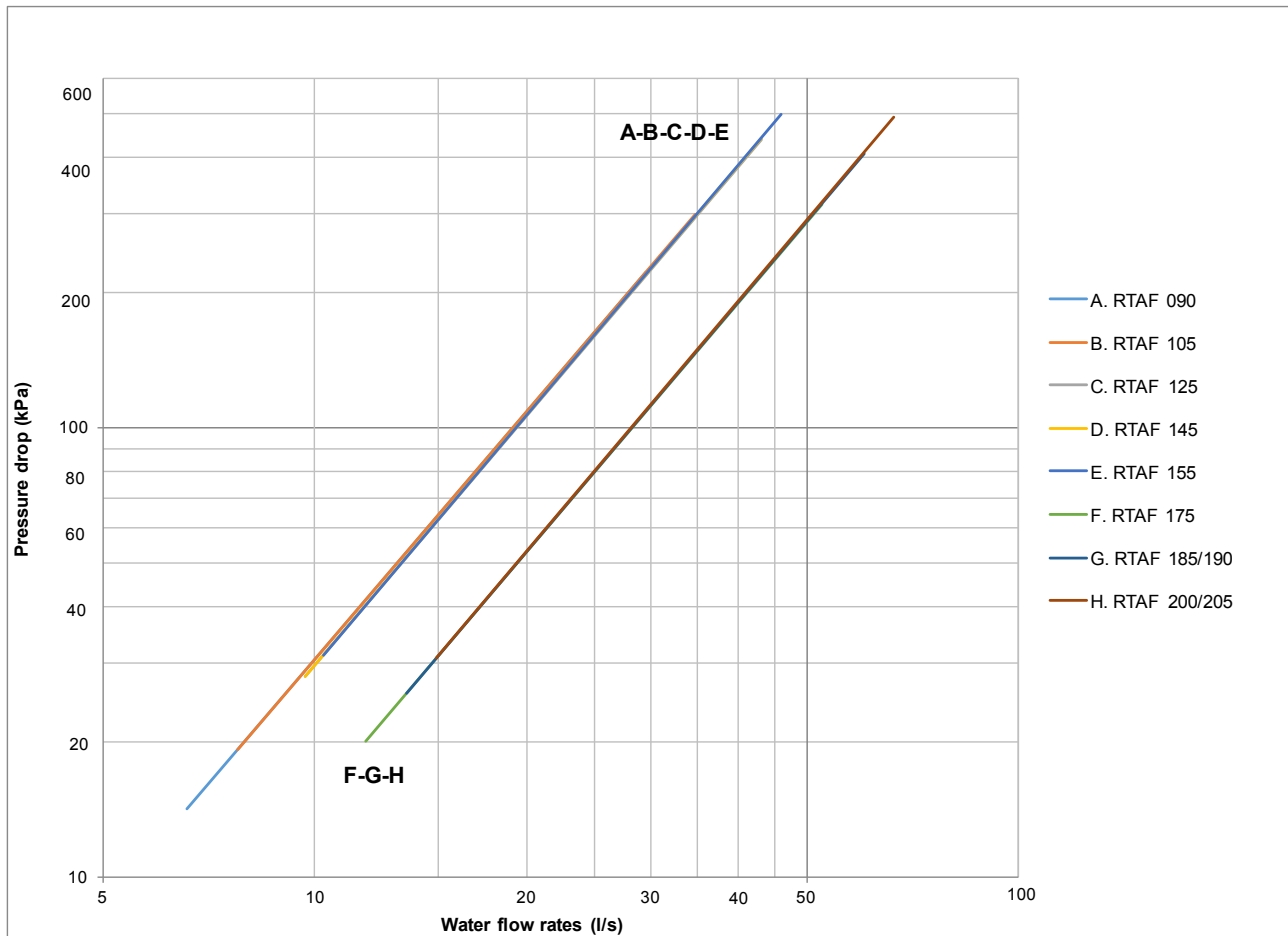

Optional Free-Cooling

Figure 30 – Water Pressure Drop - Glycol Free - Total Free Cooling - Sizes 90-205

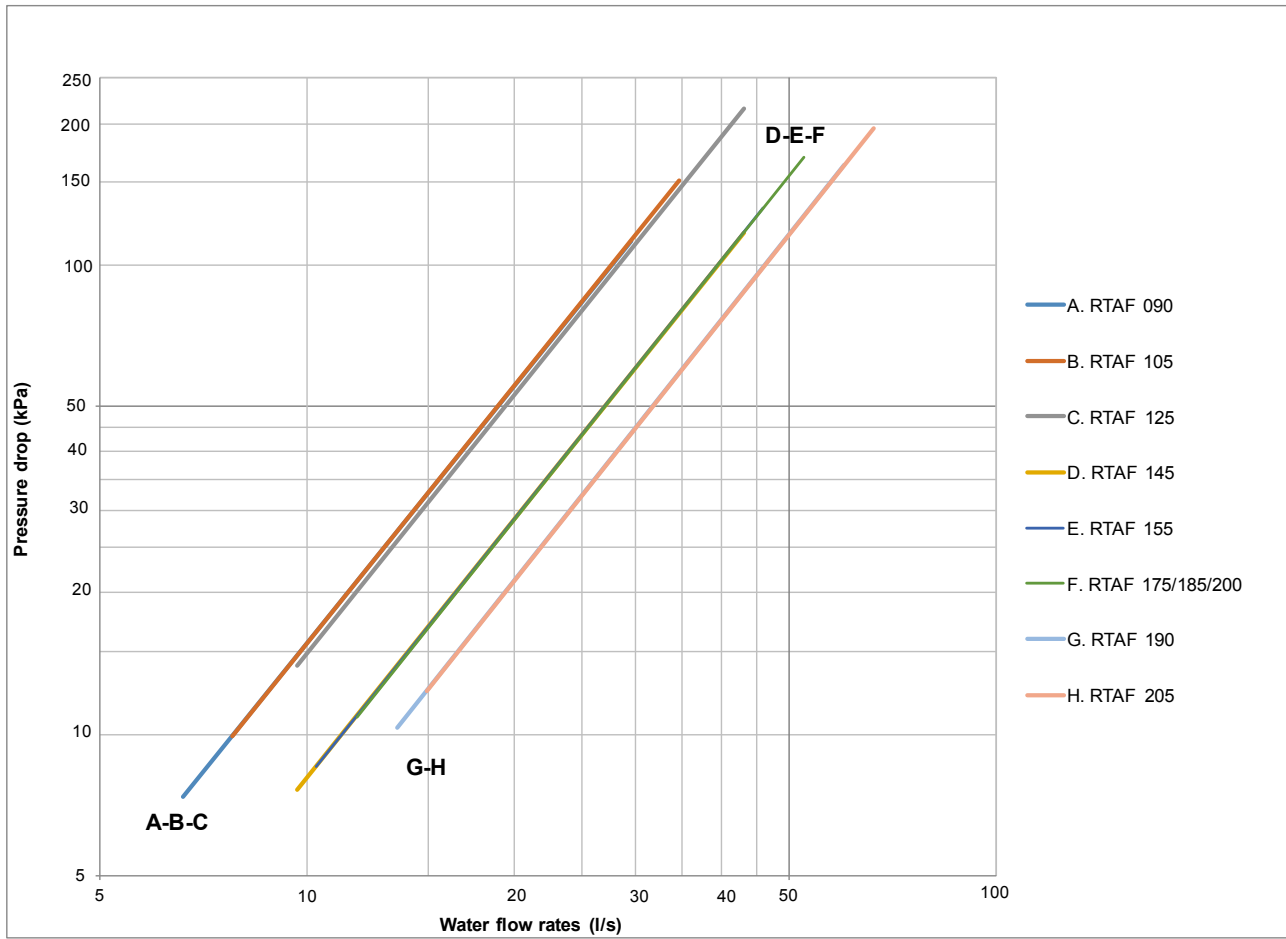

Optional Free-Cooling

Figure 31 – Water Pressure Drop - Glycol Free - Partial Free Cooling - Sizes 250- 410

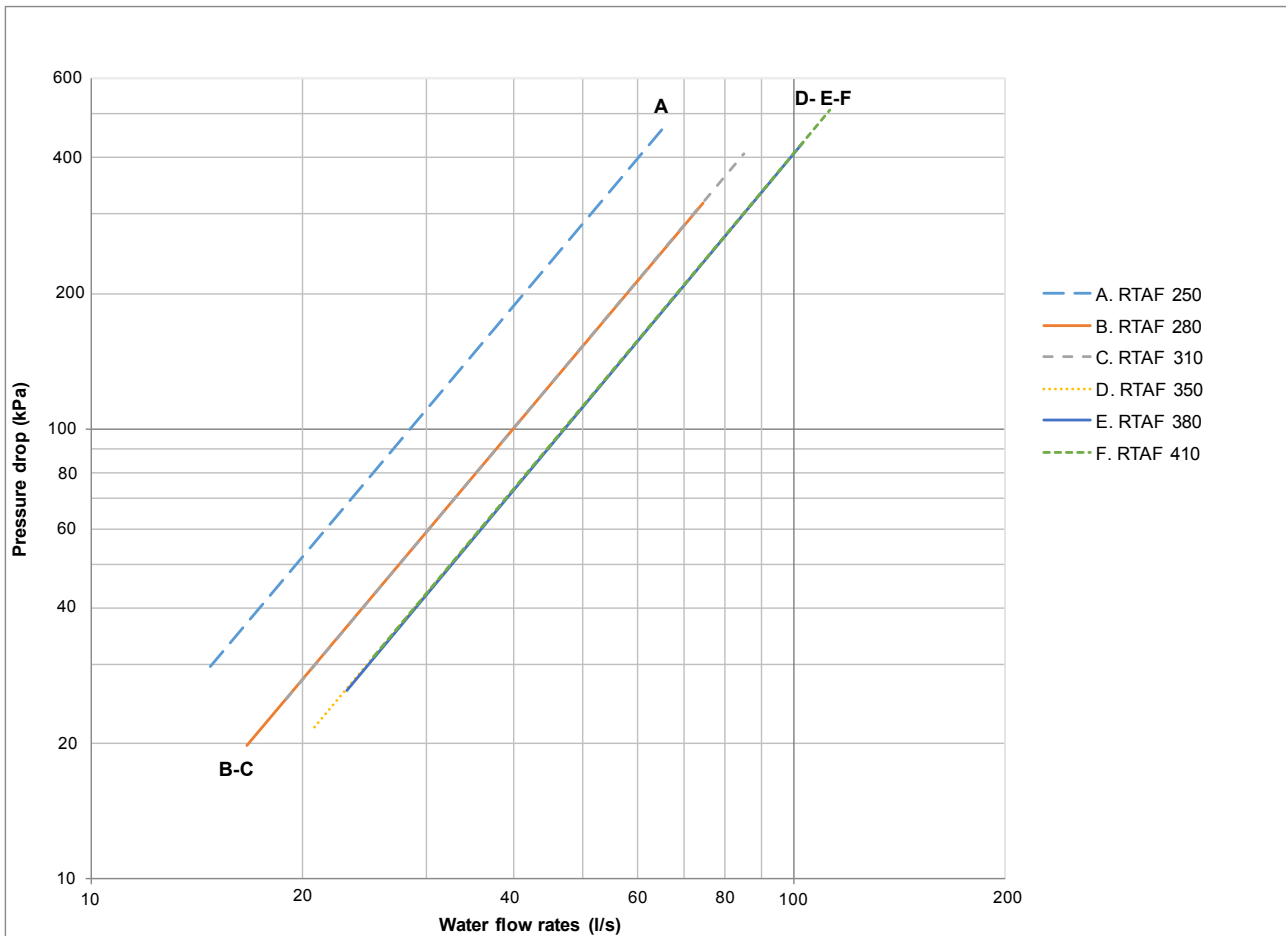

Optional Free-Cooling

Figure 32 – Water Pressure Drop - Glycol Free - Total Free Cooling - Sizes 250-410

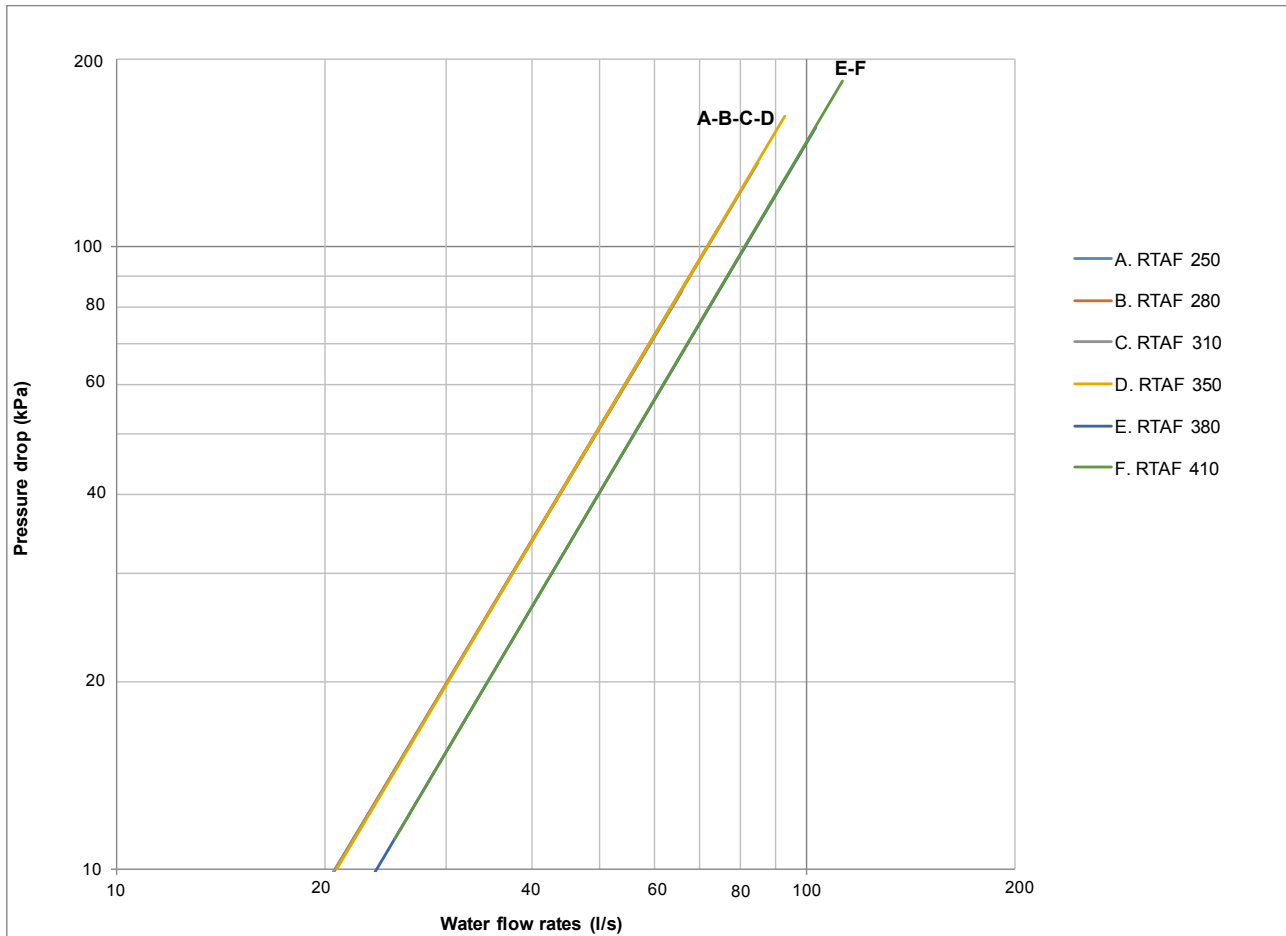

Evaporator Waterside

Freeze Protection

Depending on the ambient temperature the unit may be exposed to freeze, there are multiple options for freeze protection. They are listed in order of highest ambient (least freeze protection) to the lowest ambient (most freeze protection).

For all chiller running with water under cold ambient temperature (below 0°C), it is extremely important to keep full water flow in the evaporator for an extended time after last compressor stops. This will protect evaporator tube from freezing by refrigerant migration. This is why evaporator water pump output relay must be used to control the chilled water pump. This is not mandatory if glycol is used with protection down to lowest ambient expected.

1. Water pump and heaters

- Heaters are factory installed on water boxes and evaporator shell. They will protect it from freezing in ambient temperatures down to -20°C. Heaters are installed on the water piping and on the pumps of units equipped with hydraulic module.
- Install heat tape on all water piping, pumps, and other components that may be damaged if exposed to freezing temperatures. Heat tape must be designed for low ambient temperature applications. Heat tape selection should be based on the lowest expected ambient temperature.
- Tracer™ UC800 controller can start the pump(s) when freezing conditions are detected. For this option the pumps must be controlled by the RTAF unit and this function validated on the chiller controller.
- Water circuit valves need to stay open at all times.

Note: Water pump control and heater combination will protect the evaporator down to any ambient temperature provided power is available to the pump and the UC800 controller. This option will NOT protect the evaporator in the event of power failure to the chiller unless backup power is supplied to the necessary components.

Note: When no chiller operation is possible and the pump is already off, UC800 pump control function for freeze protection will command the pump to turn on:

- ON if the average of the evaporator entering water temperature, evaporator leaving temperature, and the evaporator refrigerant pool temperature is less than Low Evaporator Refrigerant Temperature Cutout (LERTC) + 2.2°C for a period of time
- OFF again if the evaporator refrigerant pool temperature rise above LERTC + 3.3°C for a period of time

Note: The period of time referenced for ON and OFF conditions above described is dependent on past running conditions and present temperature measured.

- ON if entering OR leaving water temperature < LWTC for 16.2°C-sec
- OFF again if water temperature > LWTC for 30 min

OR

2. Freeze inhibitor

- Freeze protection can be accomplished by adding sufficient glycol to protect against freezing down to the lowest ambient expected.
 - See “evaporator glycol requirement” section for guidance on determining the glycol concentration.
- Note:** Use of glycol type antifreeze reduces the cooling capacity of the unit and must be considered in the design of the system specifications.

OR

3. Drain water circuit

For ambient temperatures below -20°C and for those installation not including either option 1 or 2 above described

- Shut off power supply to unit and to all heaters.
- Purge the water circuit
- Blow out the evaporator to ensure that no liquid is left inside the evaporator and the water lines. Drain the pump.

CAUTION! Evaporator damage!

If insufficient concentration or no glycol is used, the evaporator water pumps must be controlled by the UC800 to avoid severe damage to the evaporator due to freezing. A power loss of 15 minutes during freezing can damage the evaporator. It is the responsibility of the installing contractor and/or the customer to ensure that a pump will start when called upon by the chiller controls. Please consult the table named “Recommended Low Evaporator Refrigerant Cutout (LRTC) and % Glycol for RTAF chillers”.

With factory-fitted disconnect switch option, evaporator trace heating is taken from the live side of the isolator. As a consequence, the heaters are energized as long as the main switch is closed. Supply voltage to the heating tapes is 400V.

Avoid the use of very low or near minimum chilled fluid flow rates through the chiller. Higher velocity chilled fluid flow reduces freeze risk in all situations.

Flow rates below published limits have increased freeze potential and have not been considered by freeze protection algorithms.

- Avoid applications and situations that result in a requirement for rapid cycling or repeated starting and stopping of the chiller. Keep in mind that chiller control algorithms may prevent a rapid compressor restart after shutting down when the evaporator has been operating near or below the LERTC limit.
- Maintain refrigerant charge at appropriate levels. If charge is in question, contact Trane service. A reduced or low level of charge can increase the likelihood of freezing conditions in the evaporator and/or LERTC diagnostic shutdowns.

The warranty will be void, in case of freezing due to the lack of use of either of these protections.



Evaporator Waterside (not for free cooling version)

Evaporator Glycol Requirement

Table 42 – Leaving water temperature cutout & glycol mass percent recommended for RTAF chillers with Standard tubes

Unit type ΔT evaporator coolant (K) LWT (°C) LWTC (°C)		Ethylene Glycol						
		2 %wt Glycol	3 %wt Glycol	4 %wt Glycol	5 %wt Glycol	6 %wt Glycol	7 %wt Glycol	8 %wt Glycol
4	1.2	-	4	4	4	4	4	5
2	-0.8	-	8	8	9	10	12	-
0	-2.8	13	13	13	15	19	-	-
-2	-4.8	18	18	19	-	-	-	-
-4	-6.8	22	22	-	-	-	-	-
-5	-7.8	24	25	-	-	-	-	-
-6	-8.8	25	29	-	-	-	-	-
-7	-9.8	27	-	-	-	-	-	-
-8	-10.8	29	-	-	-	-	-	-
-9	-11.8	31	-	-	-	-	-	-
-10	-12.8	-	-	-	-	-	-	-
-11	-13.8	-	-	-	-	-	-	-
-12	-14.8	-	-	-	-	-	-	-

Table 43 – Leaving water temperature cutout & glycol mass percent recommended for RTAF chillers with Standard tubes

Unit type ΔT evaporator coolant (K) LWT (°C) LWTC (°C)		Monopropylene Glycol						
		2 %wt Glycol	3 %wt Glycol	4 %wt Glycol	5 %wt Glycol	6 %wt Glycol	7 %wt Glycol	8 %wt Glycol
4	1.2	-	4	4	4	4	5	-
2	-0.8	10	9	10	12	-	-	-
0	-2.8	15	16	21	-	-	-	-
-2	-4.8	20	-	-	-	-	-	-
-4	-6.8	27	-	-	-	-	-	-
-5	-7.8	-	-	-	-	-	-	-
-6	-8.8	-	-	-	-	-	-	-
-7	-9.8	-	-	-	-	-	-	-
-8	-10.8	-	-	-	-	-	-	-

The table above is for RTAF sizes 090 to 245. For RTAF sizes 250 to 550, please consult your local Trane Sales Office.

Evaporator Waterside

Table 44 – Leaving water temperature cutout & glycol mass percent recommended for RTAF chillers with Turbulators

Unit type ΔT evaporator coolant (K)		Ethylene Glycol						
		2	3	4	5	6	7	8
LWT (°C)	LWTC (°C)	%wt Glycol	%wt Glycol	%wt Glycol	%wt Glycol	%wt Glycol	%wt Glycol	%wt Glycol
4	1.2	-	3	3	3	3	4	4
2	-0.8	-	8	8	9	9	10	11
0	-2.8	-	13	13	14	15	15	16
-2	-4.8	17	18	19	19	19	20	-
-4	-6.8	21	22	22	24	23	24	-
-5	-7.8	23	24	24	25	25	-	-
-6	-8.8	25	26	26	27	27	-	-
-7	-9.8	27	27	28	28	29	-	-
-8	-10.8	28	29	29	30	31	-	-
-9	-11.8	30	30	31	32	-	-	-
-10	-12.8	31	32	33	34	-	-	-
-11	-13.8	33	33	35	-	-	-	-
-12	-14.8	34	35	-	-	-	-	-

Table 45 – Leaving water temperature cutout & Ethylene Glycol mass percent recommended for RTAF chillers with standard tubes with turbulators

Unit type ΔT evaporator coolant (K)		Monopropylene Glycol						
		2	3	4	5	6	7	8
LWT (°C)	LWTC (°C)	%wt Glycol	%wt Glycol	%wt Glycol	%wt Glycol	%wt Glycol	%wt Glycol	%wt Glycol
4	1.2	-	3	3	3	4	4	6
2	-0.8	-	9	10	11	12	13	13
0	-2.8	-	16	17	18	18	19	20
-2	-4.8	20	22	22	23	24	25	-
-4	-6.8	25	26	27	28	30	-	-
-5	-7.8	27	28	29	31	-	-	-
-6	-8.8	29	30	32	-	-	-	-
-7	-9.8	31	32	-	-	-	-	-
-8	-10.8	32	34	-	-	-	-	-

The table above is for RTAF sizes 090 to 245. For RTAF sizes 250 to 550, please consult your local Trane Sales Office

Evaporator Waterside

Table 46 – Recommended Low Evaporator Refrigerant Cutout (LRTC) and % Glycol for RTAF chillers size 090 to 245

Glycol Percentage (weight %)	Ethylene Glycol			Mono Propylene Glycol		
	Solution Freeze Point (°C)	Low refrigerant temperature Cutout LRTC (°C)	Minimum Recommended LWTC (°C)	Solution Freeze Point (°C)	Low refrigerant temperature Cutout LRTC (°C)	Minimum Recommended LWTC (°C)
0	0	-1.9	1.7	0	-1.9	1.7
2	-0.6	-2.4	1.1	-0.6	-2.4	1.1
4	-1.3	-3.2	0.4	-1.2	-3.1	0.5
5	-1.7	-3.6	0	-1.5	-3.4	0.2
6	-2.1	-3.9	-0.4	-1.8	-3.7	-0.2
8	-2.8	-4.7	-1.2	-2.4	-4.3	-0.8
10	-3.6	-5.5	-1.9	-3.1	-5	-1.4
12	-4.5	-6.4	-2.8	-3.8	-5.7	-2.2
14	-5.4	-7.3	-3.7	-4.6	-6.4	-2.9
15	-5.8	-7.7	-4.2	-4.9	-6.8	-3.3
16	-6.3	-8.2	-4.7	-5.3	-7.2	-3.7
18	-7.4	-9.3	-5.7	-6.2	-8.1	-4.5
20	-8.4	-10.3	-6.8	-7.1	-8.9	-5.4
22	-9.6	-11.5	-7.9	-8	-9.9	-6.3
24	-10.8	-12.7	-9.2	-9.1	-10.9	-7.4
25	-11.4	-13.3	-9.8	-9.6	-11.4	-7.9
26	-12.1	-14	-10.4	-10.1	-12	-8.4
28	-13.5	-15.4	-11.8	-11.3	-13.2	-9.7
30	-14.9	-16.8	-13.3	-12.6	-14.5	-10.9
32	-16.5	-18.4	-14.8	-14	-15.9	-12.3
34	-18.2	-20.1	-15	-15.5	-17.4	-13.8
35	-19.1	-20.6	-15	-16.3	-18.2	-14.6
36	-19.9	-20.6	-15	-17.1	-18.9	-15
38	-21.8	-20.6	-15	-18.8	-20.6	-15
40	-23.8	-20.6	-15	-20.7	-20.6	-15
42	-25.9	-20.6	-15	-22.7	-20.6	-15
44	-28.1	-20.6	-15	-24.8	-20.6	-15
45	-29.3	-20.6	-15	-25.9	-20.6	-15
46	-30.5	-20.6	-15	-27.1	-20.6	-15
48	-32.9	-20.6	-15	-29.5	-20.6	-15
50	-35.6	-20.6	-15	-32.1	-20.6	-15

CAUTION!

1. Additional glycol beyond the recommendations will adversely affect unit performance. The unit efficiency will be reduced and the saturated evaporator temperature will be reduced. For some operating conditions this effect can be significant.
2. If additional glycol is used, then use the actual % glycol to establish the low refrigerant cutout set point.

3. The minimum low refrigerant cutout set point allowed is -20.6°C. This minimum is established by the solubility limits of the oil in the refrigerant.
4. With glycol application, ensure that there is no fluctuation of brine flow versus Order Write Up value, as a reduction of flow will adversely affect unit performance and behaviour.

Evaporator Waterside

Table 47 – Recommended Low Evaporator Refrigerant Cutout (LRTC) and % Glycol for RTAF chillers size 245 to 550

Ethylene Glycol				Mono Propylene Glycol			
Glycol Percentage (weight %)	Solution Freeze Point (°C)	Minimum Recommended LRTC (°C)	Minimum Recommended LWTC (°C)	Solution Freeze Point (°C)	Minimum Recommended LRTC (°C)	Minimum Recommended LWTC (°C)	
0	0.0	0.0	2.8	0.0	0.0	2.8	
2	-0.6	-1.4	2.2	-0.6	-1.4	2.2	
4	-1.3	-2.1	1.5	-1.2	-2.0	1.6	
5	-1.7	-2.5	1.1	-1.5	-2.3	1.3	
6	-2.0	-2.9	0.7	-1.8	-2.6	1.0	
8	-2.8	-3.6	0.0	-2.5	-3.3	0.3	
10	-3.6	-4.5	-0.8	-3.1	-4.0	-0.4	
12	-4.5	-5.3	-1.7	-3.8	-4.7	-1.1	
14	-5.4	-6.2	-2.6	-4.6	-5.4	-1.8	
15	-5.9	-6.7	-3.1	-5.0	-5.8	-2.2	
16	-6.3	-7.2	-3.6	-5.4	-6.2	-2.6	
18	-7.4	-8.2	-4.6	-6.2	-7.0	-3.4	
20	-8.4	-9.3	-5.7	-7.1	-7.9	-4.3	
22	-9.6	-10.4	-6.8	-8.0	-8.8	-5.2	
24	-10.8	-11.6	-8.0	-9.0	-9.9	-6.3	
25	-11.4	-12.3	-8.7	-9.6	-10.4	-6.8	
26	-12.1	-12.9	-9.3	-10.1	-11.0	-7.4	
28	-13.5	-14.3	-10.7	-11.3	-12.2	-8.5	
30	-15.0	-15.8	-12.2	-12.6	-13.4	-9.8	
32	-16.5	-17.3	-13.7	-14.0	-14.8	-11.2	
34	-18.2	-19.0	-15.0	-15.5	-16.3	-12.7	
35	-19.0	-19.9	-15.0	-16.3	-17.1	-13.5	
36	-19.9	-20.6	-15.0	-17.1	-17.9	-14.3	
38	-21.8	-20.6	-15.0	-18.8	-19.6	-15.0	
40	-23.8	-20.6	-15.0	-20.7	-20.6	-15.0	
42	-25.9	-20.6	-15.0	-22.6	-20.6	-15.0	
44	-28.1	-20.6	-15.0	-24.8	-20.6	-15.0	
45	-29.3	-20.6	-15.0	-25.9	-20.6	-15.0	
46	-30.5	-20.6	-15.0	-27.1	-20.6	-15.0	
48	-33.0	-20.6	-15.0	-29.5	-20.6	-15.0	
50	-35.6	-20.6	-15.0	-32.1	-20.6	-15.0	

CAUTION!

1. Additional glycol beyond the recommendations will adversely affect unit performance. The unit efficiency will be reduced and the saturated evaporator temperature will be reduced. For some operating conditions this effect can be significant.
2. If additional glycol is used, then use the actual % glycol to establish the low refrigerant cutout set point.
3. The minimum low refrigerant cutout set point allowed is - 20.6°C. This minimum is established by the solubility limits of the oil in the refrigerant.
4. With glycol application, ensure that there is no fluctuation of brine flow versus Order Write Up value, as a reduction of flow will adversely affect unit performance and behaviour.
5. Tables above should not be interpreted as suggesting operating ability or performance characteristics at all tabulated glycol percentages. Full unit simulation is required for proper prediction of unit performance for specific operating conditions. For information on specific conditions, contact Trane.

General Electrical Recommendations

Electrical Parts

When reviewing this manual keep in mind.

- All field-installed wiring must be in accordance with local regulations, CE directives and guidelines. Be sure to satisfy proper equipment grounding requirements according CE
- The following standardized values- Maximum Amps- Short Circuit Amps- Starting Amps are displayed on unit nameplate.
- All field-installed wiring must be checked for proper terminations, and for possible shorts or grounds.

Note: always refer to wiring diagrams shipped with chiller or unit submittal for specific electrical schematic and connection information.

Important: to prevent control malfunctions, do not run low voltage wiring (<30V) in conduit with conductors carrying more than 30 volts.

WARNING! Hazardous Voltage with Capacitor!

Disconnect all electric power, including remote disconnects and discharge all motor start/run and AFD (Adaptive Frequency™ Drive) capacitors before servicing. Follow proper lockout/tagout procedures to ensure the power cannot be inadvertently energized.

- For variable frequency drives or other energy storing components provided by Trane or others, refer to the appropriate manufacturer’s literature for allowable waiting periods for discharges capacitors. Verify with an appropriate voltmeter that all capacitors have discharged
- DC bus capacitors retain hazardous voltages after input power has been disconnected. Follow proper lockout/tagout procedures to ensure the power cannot be inadvertently energized

After disconnecting input power, wait five (5) minutes for units which are equipped with EC fans and wait twenty (20) minutes for units which are equipped with variable frequency drive (0V DC) before touching any internal components.

Failure to follow these instructions could result death or serious injury

For additional information regarding the safe discharge of capacitors, see “Adaptive Frequency™ Drive (AFD3) Capacitor Discharge” and BAS-SVX19B-E4.

Hazardous Voltage – Pressurized Burning Fluid!

Before removing compressor terminal box cover for servicing, or servicing power side of control panel, CLOSE COMPRESSOR DISCHARGE SERVICE VALVE and disconnect all electric power including remote disconnects. Discharge all motor start/run capacitors. Follow lockout/tagout procedures to ensure the power cannot be inadvertently energized. Verify with an appropriate voltmeter that all capacitors have discharged.

The compressor contains hot, pressurized refrigerant. Motor terminals act as a seal against this refrigerant. Care should be taken when servicing NOT to damage or loosen motor terminals.

Do not operate compressor without terminal box cover in place.

Failure to follow all electrical safety precautions could result in death or seriously injure.

CAUTION! To avoid corrosion, overheating or general damage, at terminal connections, unit is designed for copper mono-conductors only. In case of multiconductor cable, an intermediate connection box must be added. For cable with alternative material, bi-material connecting devices are mandatory. Cable routing inside control panel should be made case by case by installer. Do not allow conduit to interfere with other components, structural members or equipment. Control voltage (115V) wiring in conduit must be separate from conduit carrying low voltage (<30V) wiring. To prevent control malfunctions, do not run low voltage wiring (<30V) in conduit with conductors carrying more than 30V.

WARNING!

The Warning Label is displayed on the equipment and shown on wiring diagrams and schematics. Strict adherence to these warnings must be observed. Failure to do so may result in personal injury or death. **CAUTION!** Units must not be linked to the neutral wiring of the installation. Units are compatible with the following neutral operating conditions:

TNS	IT	TNC	TT
Standard	Special	Special	Standard*

* Differential protection should be suited for industrial machinery with current leak which can be higher than 500 mA (several motors and frequency drives).

General Electrical Recommendations

Electrical data

To get the following electrical data details: Refer to General Data tables for each unit configuration and size.

- Maximum Power input (kW)
- Unit rated amps (Max compr +Fan+Control)
- Unit start up amps (Starting Amps of the largest compr+RLA of 2nd compr+RLA of all fans+ control)
- Compressor Power factor
- Disconnect switch size (A)
- Short Circuit Rating for all sizes =35 kA

For the control of every unit

- Max power input is 1.4 kW
- Max Amps is 3.4 A

Fan data

- Motor AC : I max=4.0 A- P max=1.85 kW
- Motor EC : I max=3.0 A- P max=1.95 kW

Wiring diagrams are shipped with unit and can be found in the unit control panel.

Note : Rating is made for 400 V, 3 phases, 50 Hz power supply.

Installer-Supplied Components

Customer wiring interface connections are shown in the electrical schematics and connection diagrams that are shipped with the unit. The installer must provide the following components if not ordered with the unit:

- Power supply wiring (in conduit) for all field-wired connections
- All control (interconnecting) wiring (in conduit) for field supplied devices
- Fused-disconnect switches

Power Supply Wiring

All power supply wiring must be sized and selected accordingly by the project engineer in accordance with standard IEC 60364. All wiring must comply with local codes. The installing (or electrical) contractor must provide and install the system interconnecting wiring, as well as the power supply wiring. It must be properly sized and equipped with the appropriate fuse-disconnect switches. The type and installation location(s) of the fused-disconnect switches must comply with all applicable codes.

Cut holes into the sides of the control panel for the appropriately-sized power wiring conduits. The wiring is passed through these conduits and connected to the terminal blocks.

To provide proper phasing of 3 phase input, make connections as shown in field wiring diagrams and as stated on the yellow WARNING label in the starter panel. Proper equipment grounds must be provided to each ground connection in the panel

CAUTION! Customer wiring interface connections are shown in the electrical schematics and connection diagrams that are shipped with the unit. The installer must provide the following components if not ordered with the unit.

WARNING! To prevent injury or death, disconnect all electrical power sources before completing wiring connections to the unit.

CAUTION! The use of copper mono-conductors is the preferred solution to avoid corrosion and overheating at terminal connections.

Control Power Supply

Chiller is provided with control power transformer, it is not necessary to provide additional control power voltage to the unit.

Heater Power Supply

The evaporator shell is insulated from ambient air and protected from freezing for temperature down to -20°C by two thermostatically-controlled immersion heaters combined with evaporator pumps activation through Tracer UC800. Whenever the ambient temperature drops below 0°C the thermostat energizes the heaters and the Tracer UC800 activates the pumps. If ambient temperatures below -20°C are expected, contact your Trane local office.

CAUTION! The control panel main processor does not check for loss of power to the heat tape nor does it verify thermostat operation. A qualified technician must frequently verify power to the heat tape and confirm operation of the heat tape thermostat, to avoid catastrophic damage to the evaporator.

CAUTION! With factory-fitted disconnect switch, trace heating is taken from the live side of the isolator so power remains on. Supply voltage to the heating tapes is 400V.

In case of winter water drainage for freeze protection, it is compulsory to disconnect the evaporator heaters to protect them from burning due to overheat.

Water Pump Power Supply

Provide power-supply wiring with fused disconnect switch(es) for the chilled water pump(s).

Interconnecting Wiring

Chilled-Water Flow (Pump) Interlock

RTAF requires a field-supplied, control-voltage contact input through a flow proving switch (6S51) and an auxiliary contact (6K51). Connect the proving switch and auxiliary contact to terminal 2 connector J2 cards (1A14). Refer to the field wiring diagram for details.

Chilled-Water Pump Control

An evaporator water-pump output relay closes when the chiller is given a signal to go into the AUTO mode of operation from any source. The contact is opened to turn off the pump in the event of most machine-level diagnostics, to prevent the buildup of pump heat.

CAUTION! The evaporator water pump output relay must be used to control the chilled water pump and to benefit from the water pump timer function at startup and shutdown of the chiller. This is required when the chiller is in operation under freezing conditions, especially if the chilled water loop does not contain glycol.

CAUTION! Refer to Freeze Protection section for information about the evaporator circulating pump.

Installer-Supplied Components

Alarm and Status Relay Outputs (Programmable Relays)

See RTAF **User Guide** for alarm and status relay outputs.

EDLS and ECWS Analog Input Signal Wiring Details

See RTAF **User Guide** for EDLS and ECWS.

Operating Principles

This section describes the overall flow chart principle for RTAF. Detailed information for a given order is supplied with order package documentation.

Figure 33 – Example of Typical Refrigerant System Schematic & Oil Lube Circuit Schematic

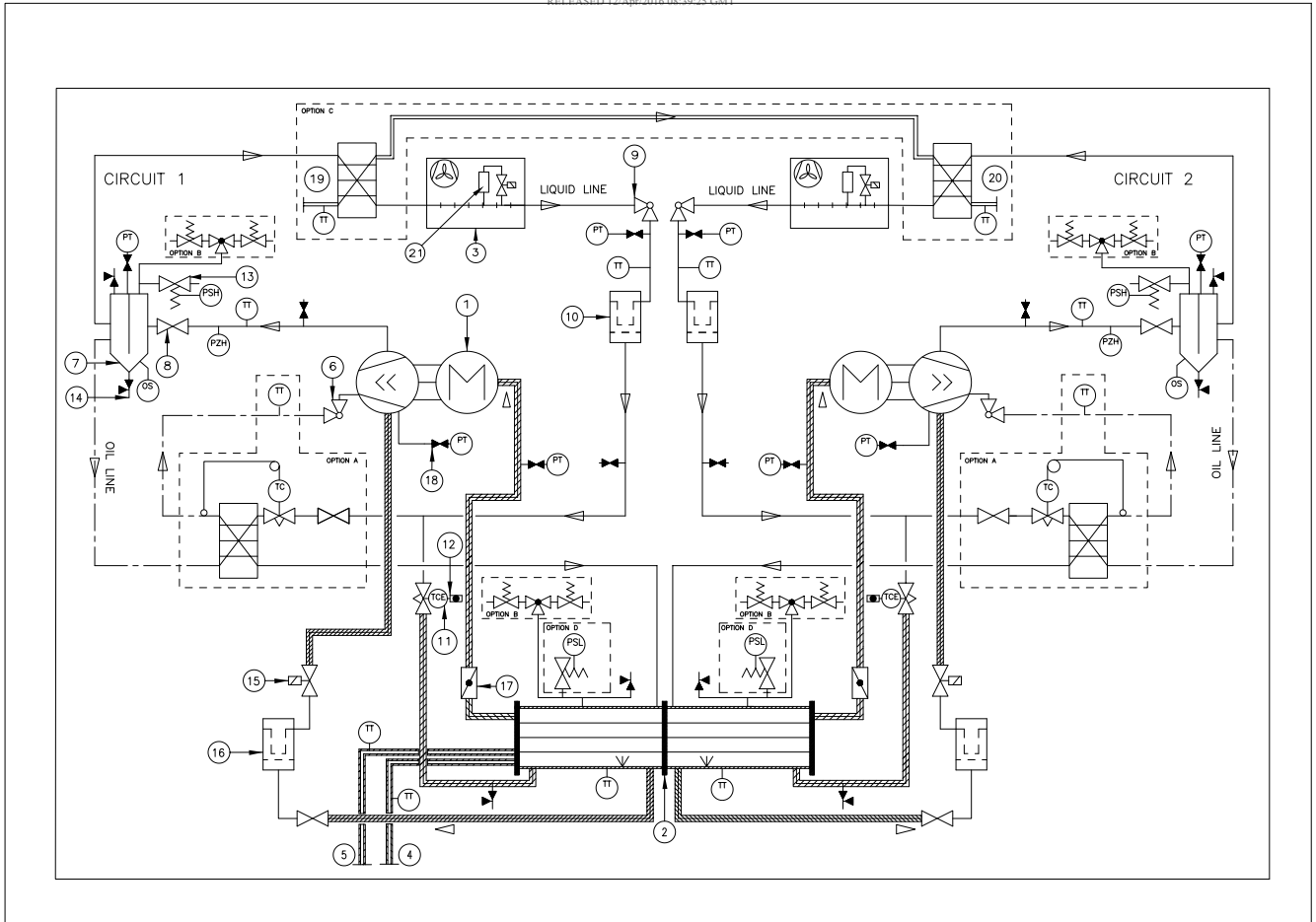

- 1 = Screw compressor
- 2 = Evaporator
- 3 = Air-cooled condenser
- 4 = Evaporator water inlet connection
- 5 = Evaporator water outlet connection
- 6 = Oil service valve
- 7 = Oil separator
- 8 = Discharge service valve
- 9 = Liquid shut off valve
- 10 = Filter drier
- 11 = Electronic expansion valve
- 12 = Sight glass
- 13 = Relief valve
- 14 = Service valve
- 15 = Oil line solenoid valve
- 16 = Oil filter
- 17 = Suction service valve
- 18 = Schraeder valve
- 19 = PHR water inlet connection
- 20 = PHR water outlet connection
- 21 = Refrigerant tank

- PT = Pressure transducer
- PSH = High pressure relief valve
- PSL = Low pressure relief valve
- PZH = High pressure switch
- TT = Temperature sensor
- TCE = Electronic expansion valve
- TC = Expansion valve
- OS = Optical sensor
- Option A = Auxilliary oil cooler
- Option B = Dual Relief Valve
- Option C = Heat Recovery
- Option D = Refrigerant tank according the unit size and the unit version

Operating Principles

Refrigerant Circuit

Each unit has two refrigerant circuits, with one or two rotary screw per circuit. Each refrigerant circuit includes a compressor suction and discharge service valve, liquid line shutoff valve, removable core filter, liquid line sight glass with moisture indicator, charging port and electronic expansion valve. Fully modulating compressors and electronic expansion valve provide variable capacity modulation over the entire operating range.

Refrigerant Cycle

Typical refrigerant cycle on the RTAF is represented on the pressure enthalpy diagram shown in the figure below. Key state points are indicated on the figure. The cycle for the full load design point is represented in the plot.

Figure 34 – Pressure enthalpy (P-h) diagram

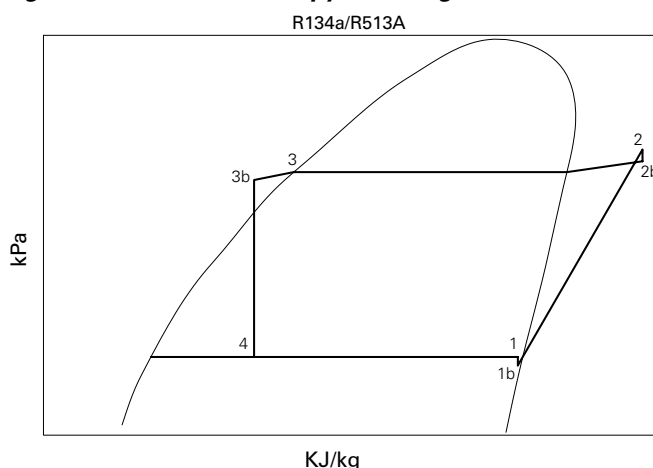

The RTAF chiller uses a shell and tube evaporator design with refrigerant evaporating on the shell side and water flowing inside tubes having enhanced surfaces (states 4 to 1). The suction lines are designed to minimize pressure drop (states 1 to 1b) the compressor is a twin-rotor helical rotary compressor designed similarly to the compressors offered in other Trane screw compressor based chiller (states 1b to 2). The discharge lines include a highly efficient oil separation system that removes 99,8% of the oil from the refrigerant stream going to the heat exchangers (states 2 to 2b). De-superheating, condensing and sub-cooling are accomplished in a microchannel cooled heat exchanger where refrigerant is condensed inside the microchannel (states 2b to 3b). Refrigerant flow through the system is balanced by an electronic expansion valve (states 3b to 4).

Refrigerant Cycle with Economizer

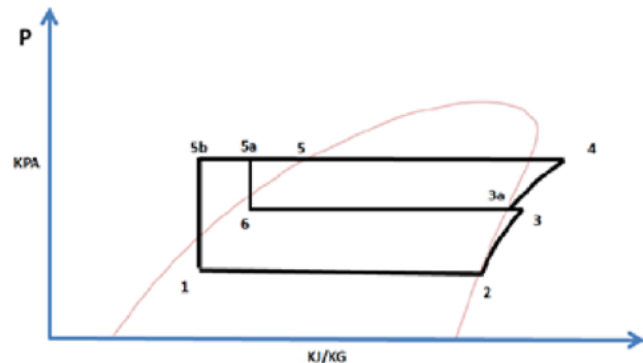

Liquid refrigerant either leaves the micro channel condenser at point 5a and a part of it flows to the secondary expansion valve and enters BPHE economizer at point 6 and then the flow is vaporized to the compressor economizer port at state 3a. Meanwhile the major part flows to BPHE economizer acting as an additive subcooler and refrigerant is cooled down to state 5b then the major part of the liquid flow goes through the main expansion valve and returns to the evaporator at state 1.

Refrigerant and Oil

RTAF use R134a, R513A or R1234ze, Trane believes that responsible refrigerant practices are important to the environment, our customers, and the air conditioning industry. All technicians who handle refrigerants must be properly qualified. All local and UE regulations in what handling, reclaiming, recovering and recycling, must be followed.

R134a/R513A/R1234ze is a medium pressure refrigerant. It may not be used in any condition that would cause the chiller to operate in vacuum without a purge system. RTAF is not equipped with a purge system. Therefore RTAF must not be operated in a condition that would result in a saturated condition in the chiller of -26°C or lower. R134a/R513A/R1234ze requires the use of specific POE oils as designated on the unit nameplate and listed on the table 31.

Table 48 – Trane oil according to refrigerant

Refrigerant	Trane OIL
R134a & R513 fixed speed compr	OIL0048E/OIL0023E
R513A	OIL0048E/OIL0023E
R134a+R513 with VFD	OIL00317/OIL00315
R1234ze	OIL00317/OIL00315 OIL066E/OIL067E possible if on nameplate

Operating Principles

Compressor and Lube Oil System

The rotary screw compressor is semi-hermetic, direct drive, with rolling element bearings, differential refrigerant pressure oil pump and oil heater. The motor is a suction gas cooled, hermetically sealed, two-pole squirrel cage induction motor.

Capacity control is done via a slide valve on fixed speed compressor on SE, HE and XE versions.

An adaptive frequency drive provides capacity control of the lead compressor on each circuit on HSE/HSS version. For maximum efficiency, larger tonnage units utilize both fixed speed and variable speed compressors staged in the same circuit.

Oil separator is provided separate from the compressor.

Oil filtration is provided internal to the compressor.

Check valves in the compressor discharge and lube oil system are also provided.

Condenser and Fans

The air cooled Microchannel condenser coils use all aluminum brazed fin construction.

The coil is composed of three components: the flat microchannel tube, the fins located between the microchannel tubes, and two refrigerant manifolds. Coils can be cleaned with high pressure water (see Condenser Coils MCHC maintenance for instructions).

The condenser coil has an integral subcooling circuit.

The maximum allowable working pressure of the condenser is 25.0 bars. Condensers are factory proof and leak tested at 45 bars.

Direct-drive vertical-discharge airfoil condenser fans are dynamically balanced.

Evaporator

The evaporator is a shell and tube heat exchanger design constructed from carbon steel shells and tube sheets with internally and externally finned seamless copper tubes mechanically expanded into the tube sheets. Tubes are cleanable with dismountable water boxes. Tubes diameter exterior is 19mm. Each tube is individually replaceable.

The evaporator is designed, tested and stamped in accordance with PED 97/23/EC or 2014/68/EU Pressure regulation for a refrigerant side working pressure of 14 bars. Standard water connections are grooved for Victaulic style pipe couplings. Water boxes are available in 1 or 2 passes configurations according to unit size and include an air vent, a drain and fittings for temperature control sensors. Evaporator is insulated with closed cell insulation.

Controls/Tracer TD7 Operator Interface

Controls Overview

Sintesis RTAF units use the following control/interface components:

- Tracer™ UC800 Controller
- Tracer TD7 Operator Interface

Communication Interfaces

There are four connections on the UC800 that support the communication interface. See RTAF User Guide to locate the following ports: “Wiring and Ports Description” section.

- BACnet MS/TP
- MODBUS Slave
- LonTalk using LCI-C (from the IPC3 bus)

See chiller User Guide for information on communication interface.

Tracer TD7 Operator Interface

Operator Interface

Information is tailored to operators, service technicians and owners. When operating a chiller, there is specific information you need on a day-to-day basis, like setpoints, limits, diagnostic information, and reports.

Day-to-day operational information is presented at the display. Logically organized groups of information-chiller mode of operation, active diagnostics, settings and reports put information conveniently at your fingertips.

Tracer™ TU

The TD7 operator interface allows for daily operation tasks and setpoint changes. However to adequately service Sintesis RTAF chillers, Tracer™ TU service tool is required (Non-Trane personnel, contact your local Trane office for software purchase information). Tracer TU adds a level of sophistication that improves service technician effectiveness and minimizes chiller downtime. This portable PC-based service-tool software supports service and maintenance tasks.

Operating Map

RTAF Operating Map R134a / R513A / R1234ze

To check unit configuration versus ambient, refer to operating map figure below: Standard ambient, High ambient or Low ambient.

- Standard ambient units:
-10°C ≤ Air temperature ≤ 46°C
- Low ambient units:
-20°C ≤ Air temperature ≤ 46°C
- High ambient units:
-10°C ≤ Air temperature ≤ 55°C

Figure 35 – RTAF Operating Map

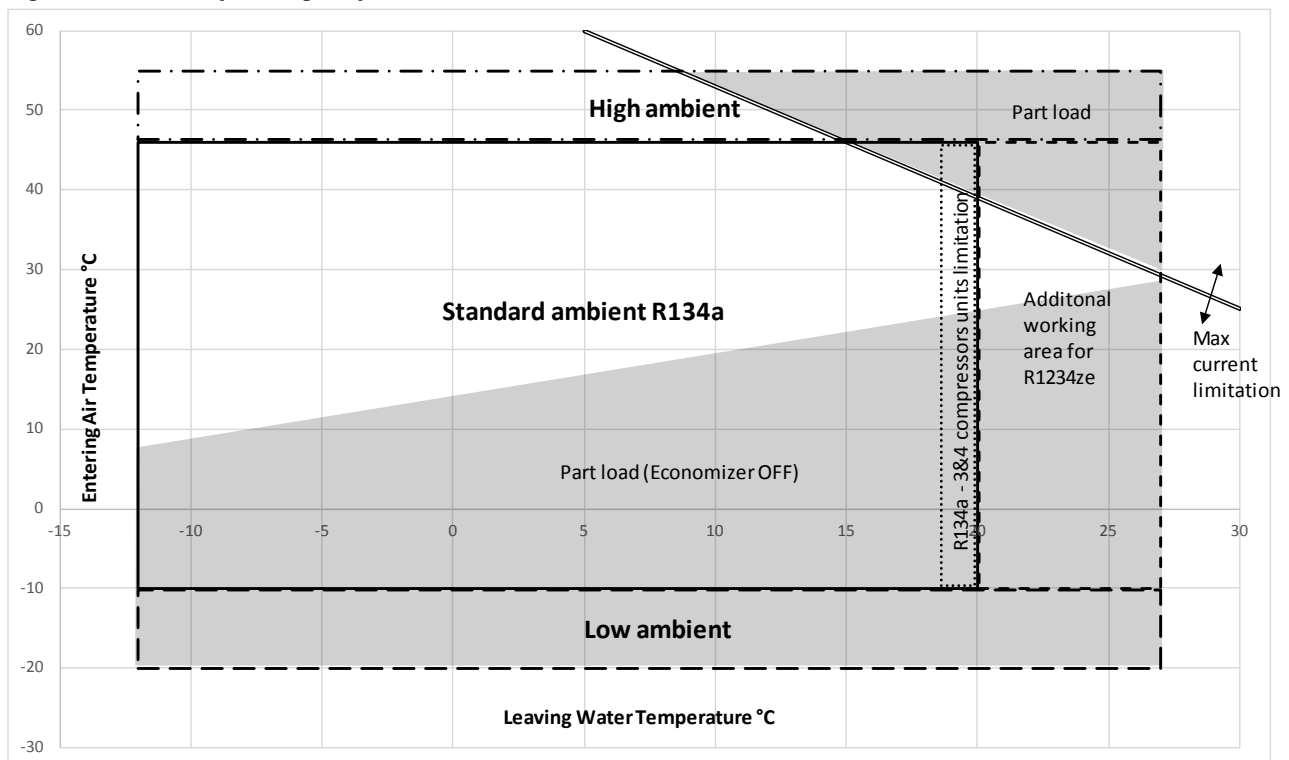

Notes:

- Minimum start-up/operation at low ambient air temperature based on wind speed lower than 2m/s.
- Maximum ambient operation is for unit at 12°C/7°C operating conditions.
- It is not possible to have a unit operating low and high ambient. For specific application with wide ambient contact Trane sales office.
- For RTAF 250 to 450 with a single pass evaporator, Leaving Water Temperature cannot exceed 18.3°C.
- The curve of limit current may vary from one machine size to another, but it will always be a parallel curve to that shown in the operating map.
- * Economizer is only available in the RTAF sizes 355 & 450 SE/HE/XE and 370, 400, 510 & 550 HSE.

Pre-Start Checkout

Installation Checklist

Complete this checklist as the unit is installed, and verify that all recommended procedures are accomplished before the unit is started. This checklist does not replace the detailed instructions given in the "Installation Mechanical" and "Installation Electrical" sections of this manual. Read both sections completely, to become familiar with the installation procedures, prior beginning the work.

General

When installation is complete, before starting the unit, the following prestart procedures must be reviewed and verified:

1. Inspect all wiring connections in the compressor power circuits (disconnects, terminal block, contactors, compressor junction box terminals and so forth) to ensure they are clean and tight.
2. Open all refrigerant valves in the discharge, liquid, and oil return lines.
3. Check the power-supply voltage to the unit at the main-power fused-disconnect switch. Voltage must be within the voltage use range and also stamped on the unit nameplate. Voltage fluctuation must not exceed 10%. Voltage imbalance must not exceed 2%.
4. Check the unit power phasing L1-L2-L3 in the starter to ensure that it has been installed in a "A-B-C" phase sequence.
5. Fill the evaporator chilled-water circuit. Vent the system while it is being filled. Open the vents on the top of the evaporator water box while filling and close when filling is completed.
6. Close the fused-disconnect switch(es) that supplies power to the chilled-water pump starter.
7. Start the chilled-water pump to begin circulation of the water. Inspect all piping for leakage and make any necessary repairs.
8. With water circulating through the system, adjust the water flow and check the water pressure drop through the evaporator.
9. Adjust the chilled-water flow switch for proper operation.
10. Reapply power to complete the procedures
11. Prove all Interlock and Interconnecting Wiring Interlock and External as described in the Electrical Installation section.
12. Check and set, as required, all UC800TD7 menu items.
13. Stop the chilled-water pump.
14. Energize the compressor and oil separator heaters 24 hours, prior to unit start up.

Unit Voltage Power Supply

Unit voltage must meet the criteria given in the installation Electrical Section. Measure each lead of the supply voltage at the main power fused-disconnect switch for the unit. If the measured voltage on any lead is not within the specified range, notify the supplier of the power and correct the situation before operating the unit.

Unit Voltage Imbalance

Excessive voltage imbalance between the phases of a three-phase system can cause motors to overheat and eventually fail. The maximum allowable unbalance is 2%. Voltage imbalance is determined using the following calculations:

$$\% \text{ Imbalance} = [(V_x - V_{ave}) \times 100 / V_{ave}]$$

$$V_{ave} = (V_1 + V_2 + V_3) / 3$$

V_x = phase with greatest difference from V_{ave} (without regard to the sign)

Unit Voltage Phasing

It is important that proper rotation of the compressors be established before the unit is started. Proper motor rotation requires confirmation of the electrical phase sequence of the power supply. The motor is internally connected for clockwise rotation with the incoming power supply phases A-B-C.

When rotation is clockwise, the phase sequence is usually called "ABC"; when counterclockwise "CBA"

This direction may be reversed by interchanging any two of the line wires.

1. Stop the unit from TD7/UC800.
2. Open the electrical disconnect or circuit protection switch that provides line power to the line power terminal block(s) in the starter panel (or to the unit mounted disconnect).
3. Connect the phase-sequence indicator leads to the line power terminal block (L1-L2-L3).
4. Turn power on by closing the unit supply-power fused-disconnect switch.
5. Read the phase sequence on the indicator. The ABC LED of the phase indicator will glow.

Pre-Start Checkout

WARNING! It is imperative that L1, L2, and L3 in the starter be connected in the A-BC phase sequence to prevent equipment damage due to reverse rotation.

WARNING! To prevent injury or death due to electrocution, take extreme care when performing service procedures with electrical power energized.

CAUTION! Do not interchange any load leads that are from the unit contactors or the motor terminals. Doing so may damage the equipment.

Water System Flow Rates

Establish a balanced chilled-water flow through the evaporator. The flow rates should be between the minimum and maximum values given on the pressure drop curves.

Water System Pressure Drop

Measure the water-pressure drop through the evaporator on the field installed pressure taps on the system water piping. Use the same gauge for each measurement. Do not include valves, strainers, or fittings in the pressure drop readings.

Integrated Pump Package (Optional)

Before starting up the pump, the pipe system must be thoroughly cleaned, flushed and filled with clean water. Do not start the pump until it has been vented. To ensure correct venting, open the vent screw located on the pump housing on the suction side (see next figure).

The warranty does not cover any damage caused by flushing the pipe system by means of the pump.

Shaft seal run-in : the seal faces are lubricated by the pumped liquid, meaning that there may be a certain amount of leakage from the shaft seal.

When the pump is started up for the first time, or when a new shaft seal is installed, a certain run-in period is required before the leakage is reduced to an acceptable level. Under normal conditions, the leaking will evaporate. As a result no leakage will be detected.

CAUTION! When using freeze inhibitor, never fill the system with pure glycol; this will damage the shaft seal. Always fill the system with diluted solution. Maximum concentration of glycol is 45% for unit with pump package.

If the chiller is installed in a humid environment or a location with high air humidity, the bottom drain hole on the pump motor should be opened. The enclosure class of the motor is then changed from IP55 to IP44. The function of the drain holes is to drain off water which has entered the stator housing with air humidity.

Figure 36 – Pump Package

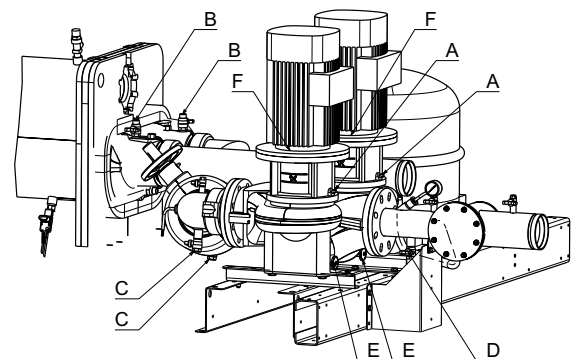

A = Pump vent screw
B = Air vent valve
C = Drain valve
D = Drain and fill valve
E = Pump drain plug
F = Motor drain hole plug

Expansion Tank (Pump Package Option)

The factory installed expansion tank initial pressure should be adjusted about 0.5 bars higher than the static pressure applied to the chiller water inlet. The static pressure is given by the maximum water circuit height compare to chiller location: example: the chiller is at ground level and the circuit loop goes from basement (at-4m compare to chiller) to third floor at 10 metres above ground, the static pressure to use is 10 metres of water (1 Bar) and the expansion tank initial pressure should be 1.5 bars.

The expansion tank volume has been selected for typical loop volume. The following table summarizes the maximum volume of the chilled water loop that can be supported by the expansion tank at different conditions. If this maximum volume versus the required volume of the installation is not enough, it will be necessary to add an additional expansion tank located on the low pressure side of the installation.

Table 49 – Maximum water loop volume in function of static pressure of expansion tank

RTAF 090- 250

Static pressure	1 Bar	2 Bar	3 Bar
Pure water (l)	6342	3996	1370
Ethylene glycol 20% (l)	3409	2148	736
Ethylene glycol 30% (l)	2273	1432	491
Ethylene glycol 45% (l)	1515	955	327

RTAF 280- 550

Static pressure	1 Bar	2 Bar	3 Bar
Pure water (l)	9292	5854	2007
Ethylene glycol 20% (l)	5689	3584	1229
Ethylene glycol 30% (l)	4912	3095	1061
Ethylene glycol 45% (l)	4073	2566	880



Pre-Start Checkout

Tracer UC800 Set-Up

Using TracerTU service tool, adjust the settings. Refer to TracerTU manual and UC800 user guide for instruction on settings.

CAUTION! To prevent compressor damage, do not operate the unit until all refrigerant valves and oil-line service valves are opened.

IMPORTANT! A clear sight glass alone does not mean that the system is properly charged. Also check system discharge superheat, approach temperature and unit operating pressures.



Unit Start Up Procedures

Daily Unit Start Up

The timeline for the sequence of operation begins with a power-up of the main power to the chiller. The sequence assumes 2 circuits, 2 compressors, Sintesis air cooled RTAF chiller with no diagnostics or malfunctioning components. External events such as the operator placing the chiller in AUTO or STOP, chilled water flow through the evaporator, and application of load to the chilled-water loop causing loop water-temperature increases, are depicted and the chiller responses to those events are shown, with appropriate delays noted. The effects of diagnostics, and other external interlocks other than evaporator water-flow proving, are not considered. Note: unless the UC800TD7 and building automation system are controlling the chilled-water pump, the manual unit start sequence is as follows. Operator actions are noted.

General

If the present checkout, as discussed above, has been completed, the unit is ready to start.

1. Press the STOP key on the TD7 display.
2. As necessary, adjust the set point values on the TD7 menus using TracerTU.
3. Close the fused-disconnect switch for the chilled-water pump. Energize the pump(s) to start water circulation
4. Check the service valves on the discharge line, suction line, oil line, and liquid line for each circuit. These valves must be open (back seated) before starting the compressors.
5. Verify that chilled-water pump runs for at least one minute after the chiller is commanded to stop (for normal chilled-water systems).
6. Press the AUTO key. If the chiller control calls for cooling, and all safety interlocks are closed, the unit will start. The compressor(s) will load and unload in response to the leaving chilled – water temperature;

After the system has been operating for approximately 30 minutes and has become stabilized, complete the remaining start up procedures, as follows:

1. Check the evaporator refrigerant pressure and the condenser refrigerant pressure under Refrigerant Report on the TD7.
2. Check the EXV sight glasses after enough time has elapsed to stabilize the chiller. The refrigerant flow through the sight glasses should be clear. Bubbles in the refrigerant indicate either low refrigerant charge or excessive pressure drop in the liquid line, or an expansion valve that is stuck open. A restriction in the line can sometimes be identified by a noticeable temperature differential between the two sides of the restriction. Frost will often form on the line at this point. Proper refrigerant charges are shown in the General Information Section;
3. Measure the system discharge superheat.

4. Clean the air filter located on the door of the control panel of AFD only on following unit type:
 - RTAF HSE sizes 155 and 175 on circuit 1
 - RTAF HSE sizes 190 and 205 on each circuit

Seasonal Unit Startup Procedure

1. Close all valves and reinstall the drain plugs in the evaporator.
2. Service the auxiliary equipment according to the startup and maintenance instructions provided by the respective equipment manufacturers.
3. Close the vents in the evaporator chilled-water circuits.
4. Open all the valves in the evaporator chilled-water circuits.
5. Open all refrigerant valves.
6. If the evaporator was previously drained, vent and fill the evaporator and chilled-water circuit. When all air is removed from the system (including each pass), install the vent plugs in the evaporator water boxes.
7. Check the adjustment and operation of each safety and operating control.
8. Close all disconnect switches.
9. Refer to the sequence for daily unit start up for the remainder of the seasonal start up.

CAUTION! Ensure that the compressor and oil separator heaters have been operating for a minimum of 24 hours before starting. Failure to do so may result in equipment damage.

System Restart after Extended Shutdown

1. Verify that the liquid-line service valves, oil line, compressor discharge service valves, and optional suction service valves are open (back seated)
2. Check the oil separator oil level (see Maintenance procedures section)
3. Fill the evaporator water circuit. Vent the system while it is being filled. Open the vent on the top of the evaporator while filling, and close it when filling is completed.
4. Close the fused-disconnect switches that provide power to the chilled-water pump.
5. Start the evaporator water pump and, while water is circulating, inspect all piping for leakage. Make any necessary repairs before starting the unit.
6. While the water is circulating, adjust the water flow and check the water pressure drops through the evaporator. Refer to “water-system flow rates” and “water-system pressure drop”
7. Adjust the flow switch on the evaporator piping for proper operation
8. Stop the water pump. The unit is now ready for startup as described “Startup procedures”

Unit Start Up Procedures

CAUTION! To prevent damage to the compressor, ensure that all refrigerant valves are open before starting the unit. Do not use untreated or improperly treated water. Equipment damage may occur.

Temporary Shutdown and Restart

Temporary Shutdown is used for control operation, maintenance or to repair the unit typically less than one week.

To shut the unit down for a short time, use the following procedure:

1. Press the STOP key on the TD7. The compressors will continue to operate and, after unloading for 20 seconds, will stop when the compressor contactors de-energize.
2. Stop the water circulation by turning off the chilled water pump at least one minute after the stop of the compressors.

To restart the unit after a temporary shutdown, enable the chilled-water pump and press the AUTO key.

The unit will start normally, provided the following conditions exist:

- The UC800 receives a call for cooling and the differential-to-start is above the set point
- All system operating interlocks and safety circuits are satisfied

CAUTION! Under freezing conditions, the chilled water pump must remain in operation during the full shutdown period of the chiller if the chilled water loop does not contain glycol, to prevent any risk of evaporator freeze-up. Refer to charts 1 and 2.

Extended Shutdown Procedure

The following procedure is to be followed if the system is to be taken out of service for an extended period of time (i.e. seasonal shutdown):

1. Test the unit for refrigerant leaks and repair as necessary
2. Open the electrical disconnect switches for the chilled-water pump. Lock the switches in the "OPEN" position.
3. Close all chilled-water supply valves. Drain the water from the evaporator.
4. Open the unit main electrical disconnect and unit-mounted disconnect (if installed) and lock in the "OPEN" position.
5. At least every three months (quarterly), check the refrigerant pressure in the unit to verify the refrigerant charge integrity.
6. Optional pump. The pump is maintenance-free. If the pump is to be drained for a long period of inactivity, inject a few drops of silicone oil on the shaft between the motor stool and the coupling. This will prevent the shaft seal faces from sticking.

CAUTION! Lock the chilled-water pump disconnects open to prevent pump damage. Lock the disconnect switch in the "OPEN" position to prevent accidental startup and damage to the system when it has been set up for extended shutdown.

During an extended shutdown period, especially over the winter season, the evaporator must be drained of water, if the chilled water loop does not contain glycol, to prevent any risk of evaporator freeze-up.

Periodic Maintenance

General

Perform all maintenance procedures and inspections at the recommended intervals. This will increase the life of the chiller and minimize the possibility of costly failures.

Weekly Maintenance

After the unit has been operating for approximately 30 minutes and the system has stabilized, check the operating conditions and complete the procedures below:

1. Check on the TD7 pressure for evaporator, condenser, and intermediate oil.
2. Inspect the entire system for unusual conditions and inspect the condenser coils for dirt and debris. If the coils are dirty, refer to coil cleaning.

Monthly Maintenance

1. Perform all weekly maintenance procedures.
2. Record the system subcooling.
3. Record the system superheat.
4. Make any repairs necessary.

Annual Maintenance

1. Perform all weekly and monthly procedures
2. Check the oil sump oil level while the unit is off.

Note: Routine changing of the oil is not required. Make an oil analysis to determine the condition of the oil.

1. Have Trane or another qualified laboratory perform a compressor oil analysis to determine system moisture content and acid level. This analysis is a valuable diagnostic tool.
2. Contact a qualified service organization to leak-test the chiller, to check operating and safety controls, and to inspect electrical components for deficiencies
3. Inspect all piping components for leakage and damage.
4. Clean and repaint any areas that show signs of corrosion.
5. Clean the condenser coils.
6. Clean the air filter located on the door of the control panel of AFD only on following unit type:
 - All RTAF HSE/HSS R134a bigger than size 145 and all RTAF HSE/HSS R1234ze bigger than size 110 for circuit 1.
 - All RTAF HSE/HSS R134a bigger than size 155. All RTAF HSE/HSS R1234ze bigger than size 120 for circuit 2.
7. Check and tighten all electrical connections as necessary.

CAUTION! A clear sight glass alone does not mean that the system is properly charged. Also check the rest of the system operating conditions.

WARNING! Position all electrical disconnects in the "Open" position and lock them to prevent injury or death due to electrical shock.

Refrigerant Emission Control

Conservation and emission reduction can be accomplished by following recommended Trane operation, maintenance, and service procedures, with specific attention to the following:

1. Refrigerant used in any type of air-conditioning or refrigerating equipment should be recovered and/or recycled for reuse, reprocessed (reclaimed). Never release refrigerant into the atmosphere.
2. Always determine possible recycle or reclaim requirements of the recovered refrigerant before beginning recovery by any method.
3. Use approved containment vessels and safety standards. Comply with all applicable transportation standards when shipping refrigerant containers.
4. To minimize emissions while recovering refrigerant, use recycling equipment. Always attempt to use methods that will pull the lowest possible vacuum while recovering and condensing refrigerant into containment.
5. Refrigerant-system cleanup methods that use filters and dryers are preferred. Do not use solvents that have ozone depletion factors. Properly dispose of used materials.
6. Take extra care to properly maintain all service equipment that directly supports refrigeration service work, such as gauges, hoses, vacuum pumps, and recycling equipment.
7. Stay aware of unit enhancements, conversion refrigerants, compatible parts, and manufacturer's recommendations that will reduce refrigerant emissions and increase equipment operating efficiencies. Follow the manufacturer's specific guidelines for conversion of existing system.
8. In order to assist in reducing power-generation emissions, always attempt to improve equipment performances with improved maintenance and operations that will help conserve energy resources.

Refrigerant and Oil-charge Management

Proper oil and refrigerant charge is essential for proper unit operation, unit performances, and environmental protection. Only trained and licensed service personnel should service the chiller.

Some of the symptoms of a refrigerant under-charged unit:

- Larger-than-normal evaporator approach temperatures (leaving water temperature – saturated evaporator temperature). If the refrigerant charge is correct the approach temperature is between 1°C and 1.5°C on circuit 1 and between 2°C and 2.5°C on circuit 2. These values are given for units running at full load and with water without antifreeze
- Low Evaporator-refrigerant temperature limit
- Low Refrigerant-Temperature cutout diagnostic
- Fully-open expansion valve
- Possible whistling sound coming from liquid line (due to high vapor velocity)

Periodic Maintenance

- Possible low discharge superheat at high loads
- High condenser + Subcooler pressure drop

Some of the symptoms of a refrigerant over-charged unit

- Condenser Pressure Limit
- High –Pressure Cutout diagnostic
- More-than-normal number of fans running
- Erratic fan control
- Higher-than-normal compressor power
- Very low discharge superheat at start up if the refrigerant charge is correct the discharge superheat is between 10°C and 15°C when the unit is running at full load

- Compressor rattle or grinding sound at start up

Some of the symptoms of an oil over-charged unit

- Larger-than-normal evaporator approach temperatures (Leaving-water-temperature – Saturated Evaporator Temperature)
- Low Evaporator-refrigerant Temperature limit
- Low Refrigerant –Temperature Cutout diagnostic
- Low unit capacity
- Low discharge superheat (specially at high loads)
- Compressor rattle or grinding sound
- High oil-sump level after normal shutdown

Some of the symptoms of an oil under-charged unit

- Compressor rattling or grinding sound
- Lower-than-normal pressure drop through oil system
- Seized or Welded compressors
- Low oil-sump level after normal shutdown
- Lower-than-normal oil concentrations in the evaporator

R134a/R513A/R1234ze Field – Charging Procedure

This procedure should be followed when the unit is empty of all refrigerant and under vacuum. Add the charge through the evaporator service valve.

1. Respect refrigerant type on the nameplate and do not mix R134a with R513A
2. Note the weight of the amount of charge removed. Compare it to the nameplate value. A difference in charge may indicate a leak.
3. Attach the charging hose to the evaporator service valve (9mm [3/8inch] flare). Open the service valve.
4. Add charge to the evaporator to bring the total circuit charge up to the level indicated in the unit nameplate.
5. Close the service valve and disconnect the charging hose.

Chiller settings

Prior starting refrigerant charge optimization, the technician must insure the following chiller conditions:

- Constant water flow on a air purged circuit is strictly necessary during the whole operation (water flow to be within allowed operating range)
- A fully loaded chiller is highly recommended for a successful operation. In case the technician is not able to

ensure a 2 circuit fully loaded chiller then he must lockout one circuit and perform charge optimization for 1 circuit at a time

- When the refrigerant charge optimization is done per circuit the chiller load must not be lower than 60%

This procedure should be followed when adding refrigerant to an undercharged unit:

1. Attach the charging hose to the evaporator service valve (9mm [3/8inch] flare). Open the service valve.
2. Fix the leaving water set point (water temperature to be steady as much as possible).
3. Adjust water flow within operating range and keep it steady.
 - a) Note approach temperature T1
 - b) Add 2kg of R134a, R513A or R1234ze refrigerant
 - c) Note approach temperature T2
 - d) If $T_n - T_{n+1} < 0.2$ (with $n=1 \rightarrow$ charge addition count) then charge is good and optimization is done
 - e) If $T_n - T_{n+1} > 0.2$ (with $n=1 \rightarrow$ charge addition count) then perform steps b) to e) if needed

This procedure should be followed when removing refrigerant to an overcharged unit:

1. Fix the leaving water set point (water temperature to be steady as much as possible)
2. Adjust water flow within operating range and keep it steady
 - a) Note approach temperature T1
 - b) Add 2kg of R134a or R513A or R1234ze refrigerant
 - c) Note approach temperature T2
 - d) Keep performing step b until $T_{m+1} - T_m > 0.5$ (with $m = 1 >$ charge removal count)
 - e) Once step d) is confirmed add 4kg of R134a, R513A or R1234ze refrigerant and note T3
 - f) If $T_1 - T_n < 0.2$ (with $n = 3 \rightarrow$ charge addition count) then charge is good and optimization is done
 - g) If $T_1 - T_n >$ (with $n = 3 \rightarrow$ charge addition count) then perform step e) to f) if needed

Isolation of the Refrigerant Charge on the Low side of the System

By closing the suction-line service valve, refrigerant charge can be isolated in the evaporator for maintenance on the compressor.

Returning the unit to running conditions:

1. Open all the valves.
2. Manually Open EXV for 15 minutes to allow the refrigerant drain to the evaporator by gravity.
3. Let the unit sit with heaters on to drive refrigerant out of the oil and warm up the compressor bearings. Depending upon ambient conditions, this may take up to 24 hours.
4. After the oil level has returned to normal, the unit can be put back into operation.

Periodic Maintenance

Low side Charge-isolation Procedure

After normal shutdown, most of the charge resides in the evaporator. Running cold water through the evaporator may also drive much of the refrigerant to the evaporator.

1. Make sure the circuit is off.
2. Close the suction-line isolation valve.
3. Close the liquid line service valve.
4. Close the liquid line service valve
5. Manually open the EXV
6. Use a liquid pump or vacuum pump to move refrigerant from the condenser to the evaporator. The liquid pump will only be effective if there is a lot of charge in the condenser. It may be connected to the condenser drain port on the liquid-line isolation valve.

Note: If a pump is to be used, connect it before closing this valve. This port is only isolated when the valve is back seated. If a vacuum pump is used, then connect it to the discharge-line service valve near to the oil separator. A vacuum pump will be required for part of the procedure.

The evaporator is large enough to hold all the charge, for any unit, below the centerline of the shell. Therefore, no special precautions are required to restart the unit after isolating the charge in the evaporator.

Refrigerant Filter Replacement – Changing Procedures

A dirty filter is indicated by a temperature gradient across the filter, corresponding to a pressure drop. If the temperature downstream of the filter is 4,4°C lower than the upstream temperature, the filter should be replaced. A temperature drop can also indicate that the unit is undercharged.

1. With the unit off, verify that the EXV is closed. Close the liquid-line isolation valve.
2. Attach the vacuum hose to the service port o the liquid-line filter flange.
3. Evacuate the refrigerant from the liquid-line and store.
4. Remove the vacuum hose.
5. Depress the Schrader valve to equalize pressure in the liquid line with atmospheric pressure.
6. Remove the bolts that retain the filter flange.
7. Remove the old filter element.
8. Inspect the replacement filter element and lubricate the o-ring with Trane oil advised for the unit (see general data table).
9. Install the new filter element in the filter housing.
10. Inspect the flange gasket and replace it with a new one if damaged.
11. Install the flange and torque the bolts to 19-22 Nm (14-16 lb-ft).
12. Attach the vacuum hose and vacuum the liquid line.

13. Remove the vacuum hose from the liquid and attach the charging hose.
14. Replace the stored charge in the liquid line.
15. Remove the charging hose.
16. Open the liquid-line isolation valve.

Lubrication System

The lubrication system has been designed to keep most of the oil lines filled with oil as long as there is a proper oil level in the oil sump.

The total oil charge can be removed by draining the oil system, the oil return line from the evaporator, the evaporator, and the compressor. Very small quantities of oil may be found in other components.

Proper charging of the oil system is critical to the reliability of the compressor and chiller. Too little oil can cause the compressor to run hot and inefficiently.

When taken to an extreme, low oil level may result in instant failure of the compressor. Too much oil will result in high oil-circulation rates, which will foul the condenser and evaporator performances. This will result in inefficient operation of the chiller. Taken to an extreme, high oil levels may result in erratic expansion-valve control or shut down of the chiller due to evaporator low evaporator refrigerant temperature. Too much oil may contribute to long term bearing wear. Additionally, excessive compressor wear is probable when the compressor is started with the oil lines dry.

- Oil system consists of the following components:
- Compressor
- Oil separator
- Discharge line with service valve
- Oil line from separator to compressor
- Oil line drain (lowest point of the system)
- Oil cooler (with HA & Low temperature brine option)
- Oil temperature sensor
- Oil line shutoff valve with flare service connection
- Oil filter (internal to compressor) with flare-fitting service connection and Schrader valve
- Oil flow-control valve (internal to the compressor after the filter)
- Oil return line from evaporator with shutoff valve, oil filter, and solenoid control valve (for the manifold compressor circuits only)

Oil charging data.

The oil quantity is written on the nameplate of the unit.

Periodic Maintenance

Figure 37 – Oil system schematic: Oil level measurement.

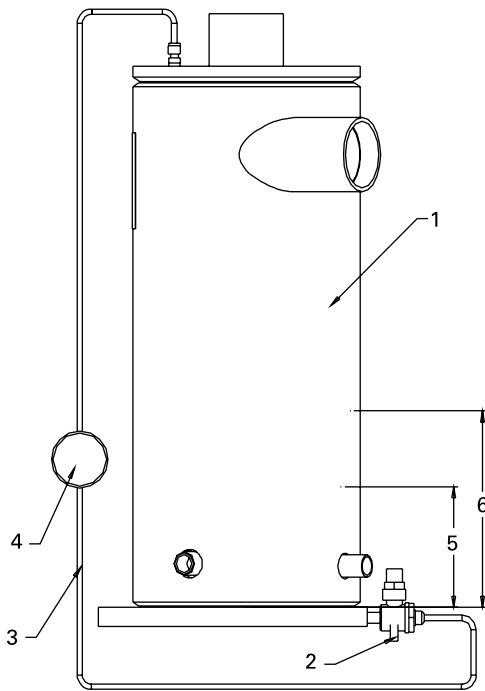

- 1 = Oil separator
- 2 = Valve
- 3 = 1/4" refrigeration hose
- 4 = Sight glass
- 5 = Minimum oil level
- 6 = Maximum oil level

How to measure the **oil level**:

1. Use the oil drain valve on the oil line and the service valve on the oil separator (bottom side). This measurement can be made, when the circuit is not running. Note: the bottom plate of the oil separator is approximately 25mm thick.
2. The initial oil charge should be approximately at the level in of the above chart. This is the approximate oil level if all the oil is in the oil lines, filter, and oil sump, and the unit is in vacuum so that there is no refrigerant dissolved in the oil.
3. After the unit has run for a while, the oil level in the sump can vary greatly. However, if the unit has run at "normal" conditions for a long time, the level should resemble the level in the above chart: Minimum level should be 50 mm, maximum should be 115 on 8" oil separators (compressors type M or L), 140 mm on 10" oil separators (compressor typ N) and 147 mm on 12" oil separators. However excessive oil in the system will deteriorate the evaporator approach temperature.

The field charging procedure depends on the circumstances that resulted in the need for oil charge.

1. Some services procedures may result in loss of small quantities of oil that must be replaced (oil analysis, compressor filter replacement, re-tubing the evaporator, and so forth).
2. Additionally, some maintenance procedures may result in virtually all the oil being removed (compressor motor burn or total removal of the charge to trouble shoot a unit).
3. Finally, leaks may result in a loss of oil that must be replaced.

Prelubrication

Prior to the oil charging procedure, a small amount of oil shall be injected in the port labeled "1" on Figure 39 Oil pushed into this location drains into the discharge port, which allows the oil to effectively cover the rotor end faces and rotor tips.

The only issue is that if the schraeder is not present on this port, the 7/16 o-ring boss plug normally in this location will have to be replaced by a 7/16-schraeder fitting (Trane part number VAL07306).

If this part is not available quickly, schraeder fitting 2 or 3 (Figure 39) could be removed and put in location 1. The plug would then replace the removed schraeder fitting.

1. Add 7/16 schraeder port where plug is shown (Figure 39).
2. Pull compressor and unit into Vacuum.
3. Connect oil line to port (Figure 38).
4. Let vacuum draw in 1/2 litre of oil.

Option: pump in 1/2 litre of oil. In any case, never complete the entire oil charge by this port. This could lead to drastic damages for the compressor. Oil injected should be preheated.

5. Remove the oil line.

Figure 38

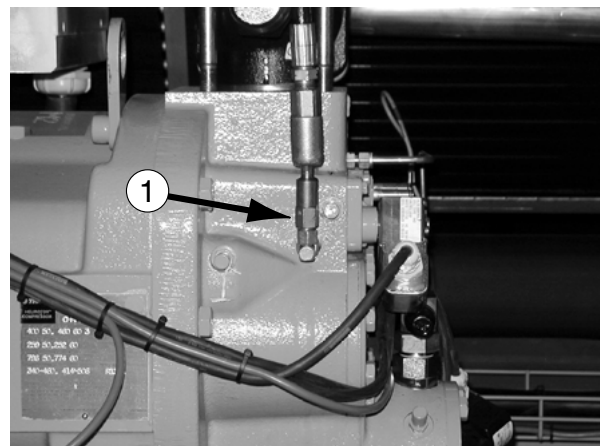

Periodic Maintenance

Figure 39 GP2 Compressor

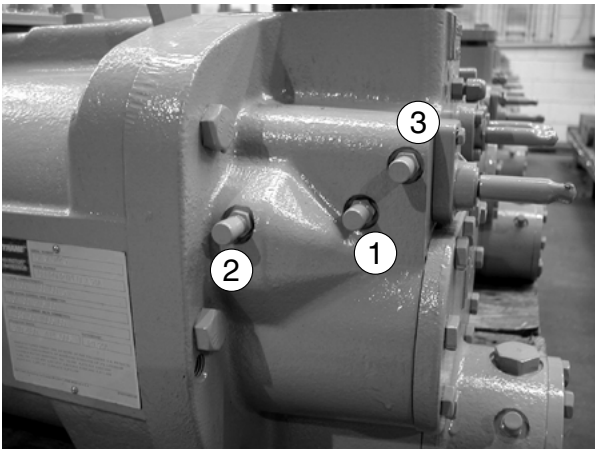
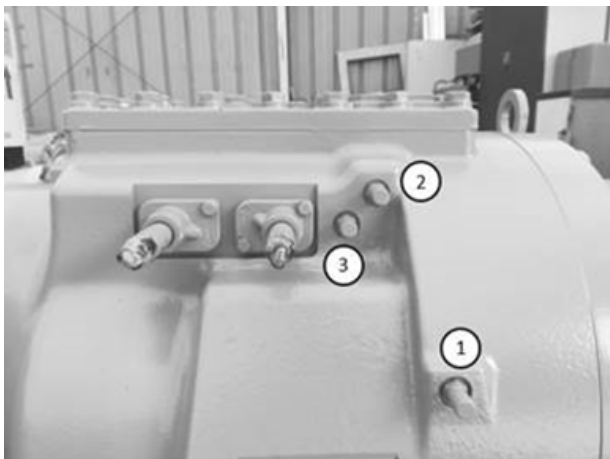

Figure 40: GP4 Compressor



Remaining Oil Charge

1. Add 0.95 litres (0.9kg) of oil to the motor cavity or suction line prior to installing the compressor into the chiller.
2. If the unit is not equipped with suction-line isolation valves, it should contain no charge. If it has isolation valves, then the charge may be trapped in the evaporator. In either case, the high side of the system should not be pressurized.
3. The oil-line shutoff valve must be open to allow the oil to pass into the oil lines and the oil separator.
4. The oil charging port is a 6mm (1/4") flare fitting with a schraeder valve that is on the side of the oil filter housing. This is the port that must be used to add oil into the compressor so that the filter and lines are full at the first start of the compressor.
5. On single-compressor circuits, all the oil should be put into the circuit through the oil-charging port on the compressor filter housing. On two-compressor circuits, put approximately 1/2 of the oil into the unit through each of the two oil-charging ports on the two compressors.
6. Oil may be put into the unit using either of two methods:

- Have the unit in vacuum. Note that the vacuum

connection should be made on the unit at the service valve that is on the discharge line. Hook up one end of the oil-charging fitting and immerse the other end into the oil container. Let the vacuum draw the required amount of oil into the unit

- Have the unit at the same pressure as the oil. Hook up one end of the oil-charging hose to the oil charging fitting and the other end to an oil pump. Use the pump to draw oil out of the oil container and push the required amount of oil into the unit

Note: the compressor filter has an internal shutoff valve that will prevent oil from entering the compressor while the compressor is not running. Therefore, there is no concern about flooding the compressor with oil.

CAUTION! Use only Trane Oil 00048E in RTAF SE HE and XE chillers and Trane OIL 00317 for HSE version in the RTAF units to avoid any catastrophic damage to the compressor or unit. Deduct from final charge, all charge added for prelubrication to avoid over-charging.

Field Oil-Charging Procedure

Use the initial charging procedure under the following circumstances;

- When virtually all of the oil has been removed
- If the oil charge is removed from the compressor and oil system only, and the unit has been run for more than 15 minutes
- If the oil charge is removed from the compressor and oil system only, and the unit has been run for more than 15 minutes. However, reduce the amount of oil added to the unit by the normal quantity of oil in the refrigeration system

Note: this procedure can be followed even with the refrigerant charge isolated in the evaporating section of the unit.

If small quantities of oil were removed to service refrigeration components, such as the evaporator, replace the oil that was removed back into the serviced component prior to vacuum and recharge of the refrigerant.

If oil was removed to service a compressor or change the filter follow this procedure:

1. If the compressor is a new compressor or has been removed from the system and reworked, add 0.95 litre (0.90kg) of oil to the motor cavity prior to installing the compressor into the chiller.
2. Install the compressor in the system. Make sure that the filter shutoff valve is closed. Other compressor isolation valves may also be closed depending upon the service that was completed. For example, changing the oil filter would require the compressor

Periodic Maintenance

to be isolated and pulled into vacuum.

Note: *Ensure that the compressor is not pressurized.*

3. Open the flare fitting on the oil-line shutoff valve.
4. Open the flare fitting on the filter housing. This is the port that must be used to put oil into the compressor.
5. Install one end of the charging hose on the oil charging port (with the Schrader valve) and the other on the oil canister.
6. Lift the oil canister, or use a pump, to pour oil into the filter housing.
7. When oil comes out of the flare fitting on the oil-line shutoff valve, the filter is full. Stop adding oil.
8. Put the cap on the flare on the oil-line shutoff valve, remove the charging hose, and put the cap back on the flare on the filter housing.

9. Vacuum the compressor (low side) and prepare it for inclusion in the system. There is a service valve on the suction line and on the evaporator. Use these valves to vacuum the compressor.
10. Open the oil-line shutoff valve. Sever damage to the compressor can result if the oil-line shutoff valve is closed when the compressor is started.
11. Open the other compressor isolation valves.

Note: this procedure assumes that the oil that is put into the filter housing does not have contaminants such as non-condensable gases. The oil forces these gases out of the filter and oil-line shutoff valve, without the need to pull a vacuum on this small volume. If the oil has been in an open container or is otherwise contaminated, then this small volume must be subject to vacuum as well. However, the filter cavity is full of oil. Therefore, be sure to use a flash tank in line with the vacuum pump to ensure that the oil that is pulled out of the filter cavity does not slug the vacuum pump.

WARNING! Catastrophic damage to the compressor will occur if the oil-line shutoff valve or the isolation valves are left closed on unit startup.

Condenser Coils MCHE Maintenance

Cleaning Procedures

It is mandatory to clean regularly the coils for a proper unit operation. Eliminate pollution and other residual material help to extend the life of the coils and the unit.

CAUTION! Equipment Damage! Do not use coil cleaning agents to clean uncoated RTAF coils. Use clean water only. Use of coil cleaning agents on uncoated RTAF coils could cause damage to coils.

Regular coil maintenance, including frequent cleaning-enhances the unit's operating efficiency by minimizing compressor head pressure and amperage draw. The condenser coil (non-coated and e-coated) should be cleaned at least once each quarter or more if the unit is located in a "dirty" or corrosive environment. Cleaning with cleansers or detergents is strongly discouraged due to the all-aluminum construction; straight water should prove sufficient. Any breach in the tubes can result in refrigerant leaks.

Important: Only in extreme cases should any type of chemical cleaner or detergent be used on micro channel coils. If it becomes absolutely necessary because water alone did not clean the coil, specify a cleaner that is:

- A is pH neutral cleaner.
- An alkaline cleaner that is no higher than 8 on the pH scale.
- An acidic cleaner that is no lower than 6 on the pH scale.
- Does not contain any hydrofluoric acids.

Be sure to follow the instructions provided with any cleaner chosen. Keep in mind that it is still MANDATORY that the coils are thoroughly rinsed with water after the application of the cleaner even if the instructions specify a "No Rinse" cleaner. Cleaners or detergents that are left on the coil due to improper rinsing will significantly increase the possibility of corrosion damage on the micro channel coil.

Note: Quarterly cleaning (or more for harsh environment) is essential to extend the life of a MCHE coil and is required to maintain warranty coverage. Failure to clean a MCHE coil will void the warranty and may result in reduced efficiency and durability in the environment.

WARNING! Hazardous Voltage! Disconnect all electric power, including remote disconnects before servicing. Follow proper lockout/ tagout procedures to ensure the power cannot be inadvertently energized. Failure to disconnect power before servicing could result in death or serious injury.

1. Disconnect Power to the unit.
2. Wear proper personal protection equipment such as a face shield, gloves and waterproof clothing.
3. Remove enough panels from the unit to gain safe access to the micro channel coil.

Note: It is better to clean the coil from the opposite direction of normal air flow (inside of unit out) because this allows the debris to be pushed out rather than forced further into the coil.

1. Use a soft brush or vacuum to remove base debris or surface loaded fibers from both sides of the coil.

Note: Remove solid residue is essential to preserve performance of the coil and avoid corrosion over the length of the product life.

2. Using a sprayer and water ONLY, clean the coil following the guidelines below.
 - a. Sprayer nozzle pressure should not exceed 40 bars.
 - b. The maximum source angle should not exceed 25 degrees (Figure 22) to the face of the coil. For best results spray the micro channel perpendicular to face of the coil.
 - c. Spray nozzle should be approximately 5 to 10 cm from the coil surface.
 - d. Use at least a 15° fan type of spray nozzle.

Figure 41 – Sprayer source angle

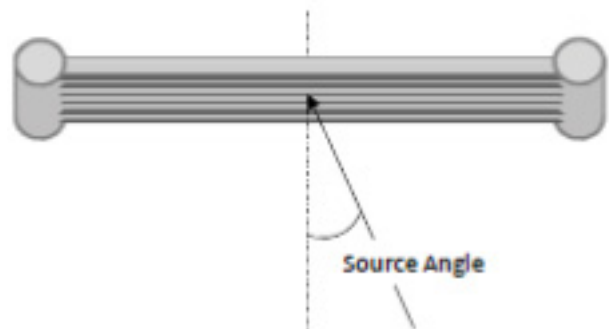

To avoid damage from the spray wand contacting the coil, make sure the 90° attachment does not come in contact with the tube and fin as abrasion to the coil could result.

Maintenance of Flanges Connection

It is mandatory to apply marine grease all around the coil flange connections to the piping on a regular basis (for instance twice a year) to avoid traps of moisture and dirt in the gasket recess.

Repair / Replacement of Micro channel Coil

Micro channel coils are considerably more robust in design than tube and fin condenser coils, however they are not indestructible. When damage or a leak occurs in the field, it is possible to temporarily repair the coil until another coil can be ordered.

If the leak is found to be within the tube area of the coil, a field repair kit (KIT16112) is available through your local Trane parts center. Because of the all-aluminum construction and aluminum's high thermal expansion rate, a leak located at or on the header assembly cannot be repaired.

Integrated Pump Maintenance (Optional with Pump Package)

Water Pump Maintenance

CAUTION! The lifting eyebolts of the motor are suitable for the weight of the motor only. It is not allowed to carry the complete pump on the lifting eyebolts of the motor.

Motor

Check the motor at regular intervals. It is important to keep the motor clean in order to ensure adequate ventilation. If the pump is installed in a dusty environment, both pump and motor must be cleaned and checked regularly.

Lubrication

The pump shaft seal does not require any special maintenance. Visual leakage check are however required. Distinctly visible leakage will require an exchange of the seal.

The bearing of motors must be greased at the shortest period (4000 hours , maintenance nameplate or yearly service). The required grease quantity is 10g per bearing. The motor must run during lubrication.

Use lithium-based grease.

For further details about pump maintenance please consult the pump supplier website.

Figure 42 – Motor bearings

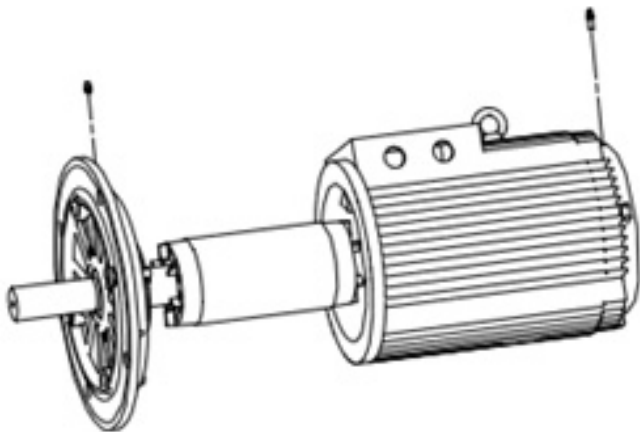



Log Check Sheet

The operator log sheet are included for use as appropriate, for installation completion verification before Trane Start-up is scheduled, and for reference during the Trane Start-up.

Operator Log				
Sintesis RTAF chiller with UC800 Controller - Tracer AdaptiView Reports - Log Sheet				
	Start	15 minutes	30 minutes	1 hour
Evaporator				
Active Chilled Water Setpoint				
Entering Water Temperature				
Leaving Water Temperature				
Ckt 1				
Saturated Refrigerant Temperature (°C)				
Refrigerant Pressure (kPa)				
Approach Temperature (°C)				
Water flow Status				
EXV % Open				
Ckt 2				
Saturated Refrigerant Temperature (°C)				
Refrigerant Pressure (psia)				
Approach Temperature (°C)				
Water flow Status				
EXV % Open				
Condenser				
Outdoor Temperature				
Ckt 1				
Air flow (%)				
Saturated Refrigerant Temperature (°C)				
Refrigerant Pressure (kPa)				
Subcooling in °C				
Ckt 2				
Air flow (%)				
Saturated Refrigerant Temperature (°C)				
Refrigerant Pressure (kPa)				
Subcooling in °C				
Compressor 1A				
Running Status				
Starts				
Running Time (Hr:min)				
Oil Pressure (kPa)				
Compressor 1B				
Running Status				
Starts				
Running Time (Hr:min)				
Oil Pressure (kPa)				
Motor 1A				
Active Demand Limit Setpoint				
Average Motor Current (%)				
Percent Speed				
AFD Average Input Current (Amps)				
AFD Average Input Voltage (Volts)				
AFD Input Power (KW)				
AFD Output Power (KW)				
AFD Speed (rpm)				
Motor 1B				
Active Demand Limit Setpoint				
Average Motor Current (%)				
Percent Speed				
AFD Average Input Current (Amps)				
AFD Average Input Voltage (Volts)				
AFD Input Power (KW)				
AFD Output Power (KW)				
AFD Speed (rpm)				
Compressor 2A				
Running Status				
Starts				
Running Time (Hr:min)				
Oil Pressure (psia)				
Compressor 2B				
Running Status				
Starts				
Running Time (Hr:min)				
Oil Pressure (psia)				
Motor 2A				
Active Demand Limit Setpoint				
Average Motor Current (%)				
Percent Speed				
AFD Average Input Current (Amps)				
AFD Average Input Voltage (Volts)				
AFD Input Power (KW)				
AFD Output Power (KW)				
AFD Speed (rpm)				
Motor 2B				
Active Demand Limit Setpoint				
Average Motor Current (%)				
Percent Speed				
AFD Average Input Current (Amps)				
AFD Average Input Voltage (Volts)				
AFD Input Power (KW)				
AFD Output Power (KW)				
AFD Speed (rpm)				
Date:				
Technician:				
Owner:				

Recommended service routine frequencies

As a commitment to our customers, we have created a wide service network staffed with experienced factory-authorized technicians. At Trane we offer all the benefits of after sales service direct from the manufacturer and we are committed to our mission statement to provide efficient customer care.

We would be delighted to discuss your individual requirement with you. For further information regarding Trane maintenance agreements please contact your local TRANE sales office.

Year	Commis- sioning	Inspec- tion visit	Seasonal shut down	Seasonal start up	Oil analysis (2)	Vibration analysis (3)	Annual mainte- nance	Preventive mainte- nance	Tube analysis (1)
1	x	x	x	x		x		xx	
2			x	x	x		x	xxx	
3			x	x	x		x	xxx	
4			x	x	x		x	xxx	
5			x	x	x	x	x	xxx	x
6			x	x	x	x	x	xxx	
7			x	x	x	x	x	xxx	
8			x	x	x	x	x	xxx	
9			x	x	x	x	x	xxx	
10			x	x	x	x	x	xxx	x
over 10			every year	every year	every year (2)	x	every year	3 every year	every 3 years

This timetable is applicable to units operating in normal conditions with an average of 4000 hours per year. If operating conditions are abnormally severe, an individual timetable must be made for that unit.

- (1) Tube testing required if aggressive water conditions exist. Applies to condensers only on water cooled units.
- (2) Schedule as per previous analysis result or at least once a year.
- (3) Year 1 to define equipment baseline. Subsequent year based on oil analysis results or schedule as per vibration analysis.

Seasonal start up and shutdown are mainly recommended for Comfort Air Conditioning and annual and preventive maintenance are mainly recommended for Process application.

Additional services

Oil analysis

Trane Oil Analysis is a predictive tool used to detect minor issues before they become major problems. It also reduces failure detection time and allows planning for appropriate maintenance. Oil changes can be reduced by half resulting in lower operating costs and a lower impact on the environment.

Vibration analysis

Vibration analysis is required when oil analysis reveals the presence of wear indicating the start of possible bearing or motor failure. Trane oil analysis has the ability to identify the type of metallic particles in the oil which, when combined with the vibration analysis, will clearly point out the failing components.

Vibration analysis should be performed on a regular basis to build a vibration trend of the equipment and avoid unplanned downtime and costs.

System upgrade

This Service provides a consulting service.

Upgrading your equipment will increase the unit reliability and can reduce the operating costs by optimizing the controls. A list of solutions / recommendations to the system will be explained to the customer. Actual upgrade for the system will be costed separately.

Water treatment

This Service provides all of the necessary chemicals to properly treat each water system for the period designated.

The inspections will be conducted at agreed upon intervals and Trane Service First will submit a written report to the customer after each inspection.

These reports will indicate any corrosion, scaling, and alga growth in the system.

Refrigerant analysis

This Service includes a thorough analysis for contamination and solution upgrade.

It is recommended that this analysis be performed every six months.

Annual cooling tower maintenance

This Service includes the inspection and maintenance of the cooling tower at least once a year.

This involves checking the motor.

24 hours duty

This service includes emergency calls outside of the office normal working hours.

This Service is only available with a Maintenance Contract, where available.

Trane Select Agreements

Trane Select Agreements are programs tailored to your needs, your business and your application. They offer four different levels of coverage. From preventive maintenance plans to fully comprehensive solutions, you have the option of selecting the coverage that best suits your requirements.

5 years motor-compressor warranty

This Service will provide a 5 years part and labor warranty for the motor compressor only.

This Service is only available for units covered by a 5 years Maintenance Contract.

Tube analysis

- Eddy Current Tube Testing for prediction of tube failure/ wear
- Frequency - every 5 years for first 10 years (depending on the water quality), then every 3 years thereafter.

Energy enhancement

With Trane Building Advantage you can now explore cost effective ways to optimize the energy efficiency of your existing system and generate immediate savings. Energy management solutions are not only for new systems or buildings. Trane Building Advantage offers solutions designed to unlock energy savings in your existing system.

Trane - by Trane Technologies (NYSE: TT), a global climate innovator - creates comfortable, energy efficient indoor environments for commercial and residential applications. For more information, please visit trane.com or tranetechnologies.com.

Trane has a policy of continuous product and product data improvement and reserves the right to change design and specifications without notice. We are committed to using environmentally conscious print practices.

RLC-SVX19K-GB July 2024
Supersedes RLC-SVX19J-GB (July 2020)

© 2024 Trane

Confidential and proprietary Trane information